

# TOSHIBA

FILE NO. 050-200507  
(MFR'S VERSION A)

## SERVICE MANUAL

## COLOR TELEVISION

# 24AF45 24AF45C

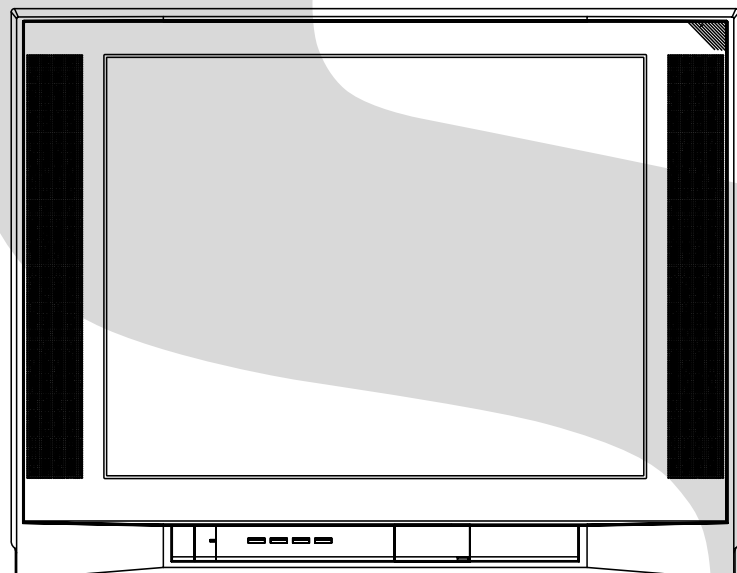

## SERVICING NOTICES ON CHECKING

### 1. KEEP THE NOTICES

As for the places which need special attentions, they are indicated with the labels or seals on the cabinet, chassis and parts. Make sure to keep the indications and notices in the operation manual.

### 2. AVOID AN ELECTRIC SHOCK

There is a high voltage part inside. Avoid an electric shock while the electric current is flowing.

### 3. USE THE DESIGNATED PARTS

The parts in this equipment have the specific characters of incombustibility and withstand voltage for safety. Therefore, the part which is replaced should be used the part which has the same character.

Especially as to the important parts for safety which is indicated in the circuit diagram or the table of parts as a  mark, the designated parts must be used.

### 4. PUT PARTS AND WIRES IN THE ORIGINAL POSITION AFTER ASSEMBLING OR WIRING

There are parts which use the insulation material such as a tube or tape for safety, or which are assembled in the condition that these do not contact with the printed board. The inside wiring is designed not to get closer to the pyrogenic parts and high voltage parts. Therefore, put these parts in the original positions.

### 5. TAKE CARE TO DEAL WITH THE CATHODE-RAY TUBE

In the condition that an explosion-proof cathode-ray tube is set in this equipment, safety is secured against implosion. However, when removing it or serving from backward, it is dangerous to give a shock. Take enough care to deal with it.

### 6. AVOID AN X-RAY

Safety is secured against an X-ray by considering about the cathode-ray tube and the high voltage peripheral circuit, etc.

Therefore, when repairing the high voltage peripheral circuit, use the designated parts and make sure not modify the circuit.

Repairing except indicates causes rising of high voltage, and it emits an X-ray from the cathode-ray tube.

### 7. PERFORM A SAFETY CHECK AFTER SERVICING

Confirm that the screws, parts and wiring which were removed in order to service are put in the original positions, or whether there are the portions which are deteriorated around the serviced places serviced or not. Check the insulation between the antenna terminal or external metal and the AC cord plug blades. And be sure the safety of that.

#### (INSULATION CHECK PROCEDURE)

1. Unplug the plug from the AC outlet.
2. Remove the antenna terminal on TV and turn on the TV.
3. Insulation resistance between the cord plug terminals and the external exposure metal **[Note 2]** should be more than 1M ohm by using the 500V insulation resistance meter **[Note 1]**.
4. If the insulation resistance is less than 1M ohm, the inspection repair should be required.

#### **[Note 1]**

If you have not the 500V insulation resistance meter, use a Tester.

#### **[Note 2]**

External exposure metal: Antenna terminal  
Headphone jack

## HOW TO ORDER PARTS

Please include the following informations when you order parts. (Particularly the VERSION LETTER.)

#### 1. MODEL NUMBER and VERSION LETTER

The MODEL NUMBER can be found on the back of each product and the VERSION LETTER can be found at the end of the SERIAL NUMBER.

#### 2. PART NO. and DESCRIPTION

You can find it in your SERVICE MANUAL.

## IMPORTANT

When you exchange IC and Transistor with a heat sink, apply silicon grease on the contact section of the heat sink. Befor applying new silicon grease, remove all the old silicon grease. (Old grease may cause damages to the IC and Transistor.)

## ABOUT LEAD FREE SOLDER (PbF)

### Distinction of PbF PCB:

PCBs (manufactured) using lead free solder will have a PbF printing on the PCB.  
(Please refer to figures.)



### Caution:

- Pb free solder has a higher melting point than standard solder;  
Typically the melting point is 50°F~70°F(30°C~40°C) higher.  
Please use a soldering iron with temperature control and adjust it to 650°F ± 20°F (350°C ± 10°C).  
In case of using high temperature soldering iron, please be carefull not to heat too long.
- Pb free solder will tend to splash when heated too high (about 1100°F/ 600°C).
- All products with the printed circuit board with PbF printing must be serviced with lead free solder.  
When soldering or unsoldering, completely remove all of the solder from the pins or solder area,  
and be sure to heat the soldering points with the lead free solder until it melts sufficiently.

### Recommendations

Recommended lead free solder composition is Sn-3.0Ag-0.5Cu.

# TABLE OF CONTENTS

<b>SERVICING NOTICES ON CHECKING</b> .....	A1-1
<b>HOW TO ORDER PARTS</b> .....	A1-1
<b>IMPORTANT</b> .....	A1-1
<b>ABOUT LEAD FREE SOLDER (PbF)</b> .....	A1-2
<b>TABLE OF CONTENTS</b> .....	A2-1
<b>GENERAL SPECIFICATIONS</b> .....	A3-1~A3-10
<b>DISASSEMBLY INSTRUCTIONS</b>	
1. REMOVAL OF ANODE CAP .....	B1-1
2. REMOVAL AND INSTALLATION OF FLAT PACKAGE IC .....	B2-1, B2-2
<b>SERVICE MODE LIST</b> .....	C-1
<b>CONFIRMATION OF HOURS USED</b> .....	C-1
<b>WHEN REPLACING EEPROM (MEMORY) IC</b> .....	C-1
<b>ELECTRICAL ADJUSTMENTS</b> .....	D-1~D-6
<b>BLOCK DIAGRAM</b> .....	E-1, E-2
<b>PRINTED CIRCUIT BOARDS</b>	
MAIN .....	F-1~F-4
CRT/VM COIL .....	F-5, F-6
<b>SCHEMATIC DIAGRAMS</b>	
MICON .....	G-1, G-2
CHROMA .....	G-3, G-4
DEFLECTION .....	G-5, G-6
POWER .....	G-7, G-8
SOUND .....	G-9, G-10
TUNER/STEREO .....	G-11, G-12
AV .....	G-13, G-14
COMB/FILTER .....	G-15, G-16
CRT/SVM .....	G-17, G-18
<b>WAVEFORMS</b> .....	H-1, H-2
<b>MECHANICAL EXPLODED VIEWS</b> .....	I-1, 1-2
<b>MECHANICAL REPLACEMENT PARTS LIST</b> .....	J1-1, J1-2
<b>ELECTRICAL REPLACEMENT PARTS LIST</b> .....	J2-1~J2-10

# GENERAL SPECIFICATIONS

<b>G-1</b>	<b>TV System</b>	CRT	CRT Size / Visual Size	24 inch / 600mmV	
			CRT Type	Flat	
			Deflection	101 degree	
			Magnetic Field BV/BH	+0.45G/0.18G	
			Color System	NTSC	
			Speaker	2 Speaker	
				Position	Front Side
				Size	2 x 4.7 Inch
				Impedance	8 ohm
			Sound Output	MAX	5.0+5.0 W
		10%(Typical)	4.0+4.0 W		
		NTSC3.58+4.43 /PAL60Hz	No		
<b>G-2</b>	<b>Tuning System</b>	Broadcasting System		US System M	
		Tuner and Receive CH	System	1Tuner	
			Destination	USA(W/ CATV)	
			Tuning System	F-Synth	
			Input Impedance	VHF/UHF 75 ohm	
			CH Coverage	2 - 69, 4A, A-5 - A-1, A - I, J - W, W+1 - W+84	
		Intermediate Frequency	Picture(FP)	45.75MHz	
			Sound(FS)	41.25MHz	
			FP-FS	4.50MHz	
			Preset CH	No	
	Stereo/Dual TV Sound	Yes			
	Tuner Sound Muting	Yes			
<b>G-3</b>	<b>Power</b>	Power Source	AC	120V AC 60Hz	
			DC		
		Power Consumption		at AC	
			Stand by (at AC)		125 W at AC 120 V 60 Hz
			Per Year		3 W at AC 120 V 60 Hz
			-- kWh/Year		
	Protector	Power Fuse	Yes		
		Safety Circuit	Yes		
		IC Protector(Micro Fuse)	No		
<b>G-4</b>	<b>Regulation</b>	Safety		UL	
		Radiation		FCC	
		X-Radiation		DHHS	
<b>G-5</b>	<b>Temperature</b>	Operation		+5oC ~ +40oC	
		Storage		-20oC ~ +60oC	
<b>G-6</b>	<b>Operating Humidity</b>			Less than 80% RH	

# GENERAL SPECIFICATIONS

G-7	On Screen Display	Menu		Yes	
		Menu Type		Icon	
		Picture		Yes	
				Contrast	Yes
				Brightness	Yes
				Color	Yes
				Tint	Yes
				Sharpness	Yes
			Sound		Yes
				Bass	Yes
				Treble	Yes
				Balance	Yes
				BBE On/Off	Yes
				Stable Sound On/Off	Yes
				Surround On/Off	Yes
			Set Up		Yes
				TV/CATV	Yes
				Auto CH Memory	Yes
				Add/ Delete	Yes
			Option		Yes
				Language	Yes
				CH Label	Yes
				Favorite CH	Yes
				V-Chip	Yes
				Lock	Yes
				On/Off Timer	Yes
				Color Stream DVD/DTV	Yes
			Control Level		Yes
				Volume	Yes
				Brightness	Yes
				Contrast	Yes
				Color	Yes
				Tint	Yes
		Sharpness	Yes		
		Tuning	No		
		Bass	Yes		
		Treble	Yes		
		Balance	Yes		
		Back Light	No		
		Stereo,Audio Output,SAP	Yes		
		Video	Yes		
		Color Stream	Yes		
		Channel(TV/Cable)	Yes		
		CH Label	Yes		
		Game Timer	Yes		
		Sleep Timer	Yes		
		Sound Mute	Yes		
		V-chip Rating	Yes		
		16: 9	Yes		
G-8	OSD Language		English French Spanish		
G-9	Clock and Timer	Sleep Timer	Max Time	120 Min	
			Step	<u>  </u> 10 <u>  </u> Min	
		On/Off Timer	Program(On Timer / Off Timer)	Yes	
		Wake Up Timer		No	
	Timer Back-up (at Power Off Mode)	more than	-- Min Sec		

# GENERAL SPECIFICATIONS

<b>G-10</b>	<b>Remote Control</b>	Unit	RC-GW		
		Glow in Dark Remocon	Yes		
		Format	Toshiba		
		Custom Code	TV:40-BF h		
		Power Source	Voltage(D.C) UM size x pcs	3V UM-4 x 2 pcs	
		Total Keys		50 Keys	
		Keys	Power	Yes	
			1	Yes	
			2	Yes	
			3	Yes	
			4	Yes	
			5	Yes	
			6	Yes	
			7	Yes	
			8	Yes	
			9	Yes	
			0	Yes	
			100	Yes	
			CH Up	Yes	
			CH Down	Yes	
			Volume Up	Yes	
			Volume Down	Yes	
			TV/Caption/Text	Yes	
			CH1/CH2	Yes	
			TV/Video(TV/AV)	Yes	
			CH RTN/CH ENT(Quick View)	Yes	
			Sleep	Yes	
			RE Call(Call)	Yes	
			Reset	Yes	
			Menu/Enter	Yes	
			Mute	Yes	
			Exit	Yes	
			MTS(Audio Select)	Yes	
			Fav.Up	Yes	
			Fav.Down	Yes	
			16: 9	Yes	
			Multi Brand Keys	CH Up(VCR)	Yes
				CH Down(VCR)	Yes
				Pause/Still	Yes
				TV/VCR(VCR)	Yes
				FF	Yes
				Rew	Yes
				Rec	Yes
				Play	Yes
				Stop	Yes
				TV	Yes
				VCR	Yes
				Cable	Yes
				DVD	Yes
				CODE	Yes
		Volume Up(DVD)	Yes		
		Volume Down(DVD)	Yes		
		DVD CLEAR	Yes		
		TOP MENU	Yes		
		DVD MENU	Yes		
		DISPLAY	Yes		

## GENERAL SPECIFICATIONS

<b>G-11</b>	<b>Features</b>	Auto Degauss	Yes
		Auto Shut Off	Yes
		Canal+	No
		CATV	Yes
		Anti-theft	No
		Rental	No
		Memory(Last CH)	Yes
		Memory(Last Volume)	Yes
		V-Chip	Yes
		Type	<u>USA,Toshiba Type</u>
		BBE	Yes
		Auto Search	No
		CH Allocation	No
		SAP	Yes
		Just Clock Function	No
		CH Label	Yes
		VM Circuit	Yes
		Full OSD	No
		Premiere	No
		Comb Filter	Yes <u>3 Lines</u>
		Auto CH Memory	Yes
		Hotel Lock	No
		Closed Caption	Yes
		Stable Sound	Yes
		FBT Leak Test Protect	Yes
		CH Lock	Yes
		Video Lock	Yes
		Game Timer (Max Time:120 Min)	Yes
		Energy Star	No
		Favorite CH	Yes
		Surround	Yes
		16:9 Mode	Yes
		<b>G-12</b>	<b>Accessories</b>
	English/Spanish		
Remote Control Unit			
	Yes		
Rod Antenna			
	No		
	Poles		
	Terminal		
Loop Antenna			
	No		
	Terminal		
	-		
U/V Mixer			
	No		
DC Car Cord (Center+)			
	No		
Guarantee Card			
	No		
Warning Sheet			
	No		
Circuit Diagram			
	No		
Antenna Change Plug			
	No		
Service Station List			
	No		
Important Safety Instruction			
	No		
Dew/AHC Caution Sheet			
	No		
AC Plug Adapter			
	No		
Quick Set-up Sheet			
	No		
Battery			
	Yes		
	UM size x pcs		
	UM-4 x 2		
	OEM Brand		
	No		
AC Cord			
	No		
AV Cord (2Pin-1Pin)			
	No		
Registration Card (NDL Card)			
	Yes		
PTB Sheet			
	No		
ESP Card			
	No		
300 ohm to 75 ohm Antenna Adapter			
	No		

# GENERAL SPECIFICATIONS

<b>G-13</b>	<b>Interface</b>	Switch	Front	Power	Yes
				System Select	No
				Main Power SW	No
				Sub Power	No
				Channel Up	Yes
				Channel Down	Yes
				Volume Up	Yes
				Volume Down	Yes
		Rear	AC/DC	No	
			TV/CATV Selector	No	
			Degauss	No	
			Main Power SW	No	
		Indicator	Power	Yes(RED)	
			Stand-by	No	
			On Timer	No	
		Terminals	Front	Video Input = VIDEO3	RCA
				Audio Input = VIDEO3	RCA x 2
				Other Terminal	Head Phone
			Rear	Video Input(Rear1) = VIDEO1	RCA
				Video Input(Rear2) = VIDEO2	RCA
				Audio Input(Rear1) = VIDEO1	RCA x 2
				Audio Input(Rear2) = VIDEO2	RCA x 2
				Video Output	RCA
				Audio Output	RCA x 2
				Euro Scart	No
				Color Stream	RCA x 3
S Input	Yes				
Diversity	No				
Ext Speaker	No				
DC Jack 12V(Center +)	No				
VHF/UHF Antenna Input	F Type				
AC Outlet	No				
<b>G-14</b>	<b>Set Size</b>	Approx. W x D x H (mm)		<u>670 x 471.5 x 509</u>	
<b>G-15</b>	<b>Weight</b>	Net (Approx.)		<u>33 kg (72.8 lbs)</u>	
		Gross (Approx.)		<u>36.5 kg (80.5 lbs)</u>	
<b>G-16</b>	<b>Carton</b>	Master Carton		No	
			Content	--- Sets	
			Material	-- /--	
			Dimensions W x D x H(mm)	-- x -- x --	
			Description of Origin	No	
		Gift Box		Yes	
			Material	Double/Brown	
			Dimensions W x D x H(mm)	<u>760 x 589 x 614</u>	
			Design	As per Buyer's	
			Description of Origin	Yes	
Drop Test		Natural Dropping At 1 Corner / 2 Edges / 4 Surfaces			
	Height (cm)	60 (ORION SPEC:31)			
	Container Stuffing	<u>180</u> Sets/40' container			
<b>G-17</b>	<b>Cabinet Material</b>	Cabinet	Cabinet Front	PS 94V0 DECABROM	
			Cabinet Rear	PS 94V0 DECABROM	
		PCB	Non-Halogen Demand	No	
			Eyelet Demand	Yes	
<b>G-18</b>	<b>Environment</b>	Pb-free Soldering	Yes		
		Parts Specificati	Yes		

# GENERAL SPECIFICATIONS

<b>G-1</b>	<b>TV System</b>	CRT	CRT Size / Visual Size	24 inch / 600mmV	
			CRT Type	Flat	
			Deflection	101 degree	
			Magnetic Field BV/BH	+0.45G/0.18G	
			Color System	NTSC	
			Speaker	2 Speaker	
				Position	Front Side
				Size	2 x 4.7 Inch
				Impedance	8 ohm
			Sound Output	MAX	5.0+5.0 W
		10%(Typical)	4.0+4.0 W		
		NTSC3.58+4.43 /PAL60Hz	No		
<b>G-2</b>	<b>Tuning System</b>	Broadcasting System		US System M	
		Tuner and Receive CH	System	1Tuner	
			Destination	USA(W/ CATV)	
			Tuning System	F-Synth	
			Input Impedance	VHF/UHF 75 ohm	
				CH Coverage	2 - 69, 4A, A-5 - A-1, A - 1, J - W, W+1 - W+84
			Intermediate Frequency	Picture(FP)	45.75MHz
				Sound(FS)	41.25MHz
				FP-FS	4.50MHz
			Preset CH		No
	Stereo/Dual TV Sound		Yes		
	Tuner Sound Muting		Yes		
<b>G-3</b>	<b>Power</b>	Power Source	AC	120V AC 60Hz	
			DC		
		Power Consumption		at AC	
			Stand by (at AC)		125 W at AC 120 V 60 Hz
			Per Year		3 W at AC 120 V 60 Hz
			-- kWh/Year		
	Protector	Power Fuse	Yes		
		Safety Circuit	Yes		
		IC Protector(Micro Fuse)	No		
<b>G-4</b>	<b>Regulation</b>	Safety		CSA	
		Radiation		IC	
		X-Radiation		HWC	
<b>G-5</b>	<b>Temperature</b>	Operation		+5oC ~ +40oC	
		Storage		-20oC ~ +60oC	
<b>G-6</b>	<b>Operating Humidity</b>			Less than 80% RH	

# GENERAL SPECIFICATIONS

G-7	On Screen Display	Menu		Yes	
		Menu Type		Icon	
		Picture		Yes	
				Contrast	Yes
				Brightness	Yes
				Color	Yes
				Tint	Yes
				Sharpness	Yes
			Sound		Yes
				Bass	Yes
				Treble	Yes
				Balance	Yes
				BBE On/Off	Yes
				Stable Sound On/Off	Yes
				Surround On/Off	Yes
			Set Up		Yes
				TV/CATV	Yes
				Auto CH Memory	Yes
				Add/ Delete	Yes
			Option		Yes
				Language	Yes
				CH Label	Yes
				Favorite CH	Yes
				V-Chip	No
				Lock	Yes
				On/Off Timer	Yes
				Color Stream DVD/DTV	Yes
			Control Level		Yes
				Volume	Yes
				Brightness	Yes
				Contrast	Yes
				Color	Yes
				Tint	Yes
		Sharpness	Yes		
		Tuning	No		
		Bass	Yes		
		Treble	Yes		
		Balance	Yes		
		Back Light	No		
		Stereo,Audio Output,SAP	Yes		
		Video	Yes		
		Color Stream	Yes		
		Channel(TV/Cable)	Yes		
		CH Label	Yes		
		Game Timer	Yes		
		Sleep Timer	Yes		
		Sound Mute	Yes		
		V-chip Rating	No		
		16: 9	Yes		
G-8	OSD Language		English French Spanish		
G-9	Clock and Timer	Sleep Timer	Max Time	120 Min	
			Step	<u>  </u> 10 <u>  </u> Min	
		On/Off Timer	Program(On Timer / Off Timer)	Yes	
		Wake Up Timer		No	
	Timer Back-up (at Power Off Mode)	more than	-- Min Sec		

# GENERAL SPECIFICATIONS

<b>G-10</b>	<b>Remote Control</b>	Unit	RC-GW	
		Glow in Dark Remocon	Yes	
		Format	Toshiba	
		Custom Code	TV:40-BF h	
		Power Source	Voltage(D.C) UM size x pcs	3V UM-4 x 2 pcs
		Total Keys		50 Keys
		Keys	Power	Yes
			1	Yes
			2	Yes
			3	Yes
			4	Yes
			5	Yes
			6	Yes
			7	Yes
			8	Yes
			9	Yes
			0	Yes
			100	Yes
			CH Up	Yes
			CH Down	Yes
			Volume Up	Yes
			Volume Down	Yes
			TV/Caption/Text	Yes
			CH1/CH2	Yes
			TV/Video(TV/AV)	Yes
			CH RTN/CH ENT(Quick View)	Yes
			Sleep	Yes
			RE Call(Call)	Yes
			Reset	Yes
			Menu/Enter	Yes
			Mute	Yes
			Exit	Yes
			MTS(Audio Select)	Yes
			Fav.Up	Yes
			Fav.Down	Yes
			16: 9	Yes
			Multi Brand Keys	
			CH Up(VCR)	Yes
			CH Down(VCR)	Yes
			Pause/Still	Yes
			TV/VCR(VCR)	Yes
			FF	Yes
			Rew	Yes
			Rec	Yes
			Play	Yes
			Stop	Yes
			TV	Yes
			VCR	Yes
			Cable	Yes
			DVD	Yes
	CODE	Yes		
	Volume Up(DVD)	Yes		
	Volume Down(DVD)	Yes		
	DVD CLEAR	Yes		
	TOP MENU	Yes		
	DVD MENU	Yes		
	DISPLAY	Yes		

## GENERAL SPECIFICATIONS

<b>G-11</b>	<b>Features</b>	Auto Degauss	Yes	
		Auto Shut Off	Yes	
		Canal+	No	
		CATV	Yes	
		Anti-theft	No	
		Rental	No	
		Memory(Last CH)	Yes	
		Memory(Last Volume)	Yes	
		V-Chip	No	
		Type		
		BBE	Yes	
		Auto Search	No	
		CH Allocation	No	
		SAP	Yes	
		Just Clock Function	No	
		CH Label	Yes	
		VM Circuit	Yes	
		Full OSD	No	
		Premiere	No	
		Comb Filter	Yes <u>3</u> Lines	
		Auto CH Memory	Yes	
		Hotel Lock	No	
		Closed Caption	Yes	
		Stable Sound	Yes	
		FBT Leak Test Protect	Yes	
		CH Lock	Yes	
		Video Lock	Yes	
		Game Timer (Max Time:120 Min)	Yes	
		Energy Star	No	
		Favorite CH	Yes	
		Surround	Yes	
		16:9 Mode	Yes	
<b>G-12</b>	<b>Accessories</b>	Owner's Manual	Language W/ Warranty	English / French Yes
		Remote Control Unit		Yes
		Rod Antenna		No
			Poles Terminal	
		Loop Antenna		No
			Terminal	-
		U/V Mixer		No
		DC Car Cord (Center+)		No
		Guarantee Card		No
		Warning Sheet		No
		Circuit Diagram		No
		Antenna Change Plug		No
		Service Station List		No
		Important Safety Instruction		No
		Dew/AHC Caution Sheet		No
		AC Plug Adapter		No
		Quick Set-up Sheet		No
		Battery		Yes
			UM size x pcs OEM Brand	UM-4 x 2 No
		AC Cord		No
		AV Cord (2Pin-1Pin)		No
		Registration Card (NDL Card)		No
		PTB Sheet		No
		ESP Card		No
		300 ohm to 75 ohm Antenna Adapter		No

# GENERAL SPECIFICATIONS

<b>G-13</b>	<b>Interface</b>	Switch	Front	Power	Yes
				System Select	No
				Main Power SW	No
				Sub Power	No
				Channel Up	Yes
				Channel Down	Yes
				Volume Up	Yes
			Volume Down	Yes	
			Rear	AC/DC	No
				TV/CATV Selector	No
				Degauss	No
			Indicator	Main Power SW	No
				Power	Yes(RED)
		Stand-by		No	
		Terminals	Front	On Timer	No
				Video Input = VIDEO3	RCA
				Audio Input = VIDEO3	RCA x 2
			Rear	Other Terminal	Head Phone
				Video Input(Rear1) = VIDEO1	RCA
				Video Input(Rear2) = VIDEO2	RCA
				Audio Input(Rear1) = VIDEO1	RCA x 2
				Audio Input(Rear2) = VIDEO2	RCA x 2
				Video Output	RCA
				Audio Output	RCA x 2
				Euro Scart	No
				Color Stream	RCA x 3
				S Input	Yes
Diversity	No				
Ext Speaker	No				
DC Jack 12V(Center +)	No				
VHF/UHF Antenna Input	F Type				
AC Outlet	No				
<b>G-14</b>	<b>Set Size</b>	Approx. W x D x H (mm)		<u>670 x 471.5 x 509</u>	
<b>G-15</b>	<b>Weight</b>	Net (Approx.)		<u>33 kg ( 72.8 lbs)</u>	
		Gross (Approx.)		<u>36.5 kg ( 80.5 lbs)</u>	
<b>G-16</b>	<b>Carton</b>	Master Carton		No	
			Content	--- Sets	
			Material	-- /--	
			Dimensions W x D x H(mm)	-- x -- x --	
			Description of Origin	No	
		Gift Box		Yes	
			Material	Double/Brown	
			Dimensions W x D x H(mm)	<u>760 x 589 x 614</u>	
			Design	As per Buyer's	
			Description of Origin	Yes	
		Drop Test		Natural Dropping At 1 Corner / 2 Edges / 4 Surfaces	
Height (cm)	60 (ORION SPEC:31)				
	Container Stuffing	<u>180</u> Sets/40' container			
<b>G-17</b>	<b>Cabinet Material</b>	Cabinet	Cabinet Front	PS 94V0 DECABROM	
			Cabinet Rear	PS 94V0 DECABROM	
		PCB	Non-Halogen Demand	No	
			Eyelet Demand	Yes	
<b>G-18</b>	<b>Environment</b>	Pb-free Soldering	Yes		
		Parts Specificati	Yes		

# DISASSEMBLY INSTRUCTIONS

## 1. REMOVAL OF ANODE CAP

Read the following **NOTED** items before starting work.

- \* After turning the power off there might still be a potential voltage that is very dangerous. When removing the Anode Cap, make sure to discharge the Anode Cap's potential voltage.
- \* Do not use pliers to loosen or tighten the Anode Cap terminal, this may cause the spring to be damaged.

### REMOVAL

1. Follow the steps as follows to discharge the Anode Cap. (Refer to Fig. 1-1.)

Connect one end of an Alligator Clip to the metal part of a flat-blade screwdriver and the other end to ground. While holding the plastic part of the insulated Screwdriver, touch the support of the Anode with the tip of the Screwdriver. A cracking noise will be heard as the voltage is discharged.

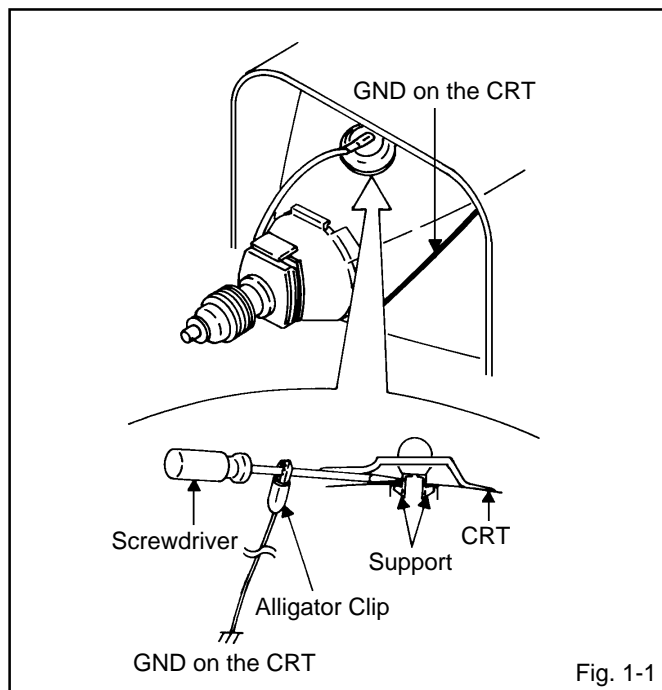

Fig. 1-1

2. Flip up the sides of the Rubber Cap in the direction of the arrow and remove one side of the support. (Refer to Fig. 1-2.)

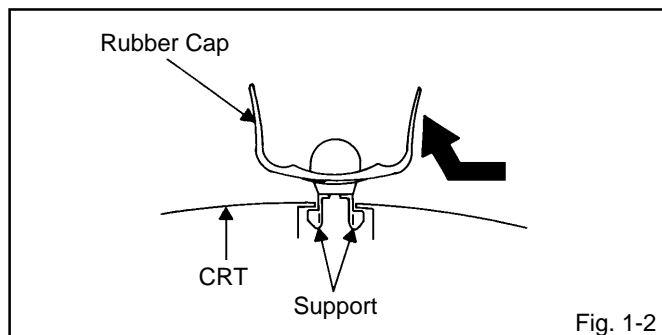

Fig. 1-2

3. After one side is removed, pull in the opposite direction to remove the other.

### NOTE

Take care not to damage the Rubber Cap.

### INSTALLATION

1. Clean the spot where the cap was located with a small amount of alcohol. (Refer to Fig. 1-3.)

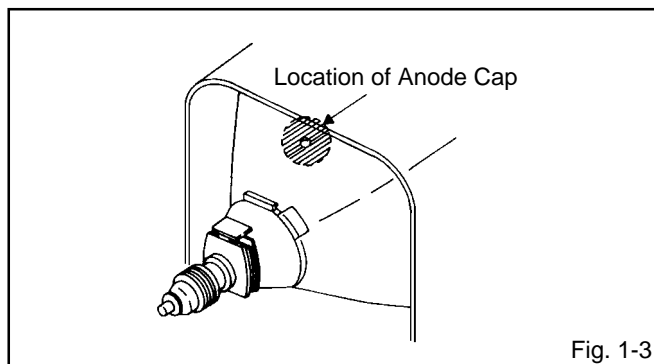

Fig. 1-3

### NOTE

Confirm that there is no dirt, dust, etc. at the spot where the cap was located.

2. Arrange the wire of the Anode Cap and make sure the wire is not twisted.
3. Turn over the Rubber Cap. (Refer to Fig. 1-4.)

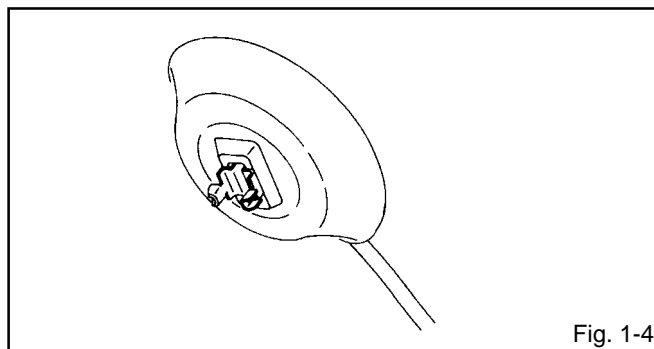

Fig. 1-4

4. Insert one end of the Anode Support into the anode button, then the other as shown in Fig. 1-5.

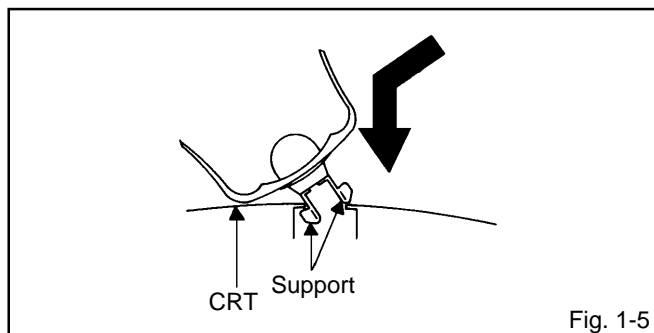

Fig. 1-5

5. Confirm that the Support is securely connected.
6. Put on the Rubber Cap without moving any parts.

# DISASSEMBLY INSTRUCTIONS

## 2. REMOVAL AND INSTALLATION OF FLAT PACKAGE IC

### REMOVAL

1. Put Masking Tape (cotton tape) around the Flat Package IC to protect other parts from any damage. (Refer to Fig. 2-1.)

#### NOTE

Masking is carried out on all the parts located within 10 mm distance from IC leads.

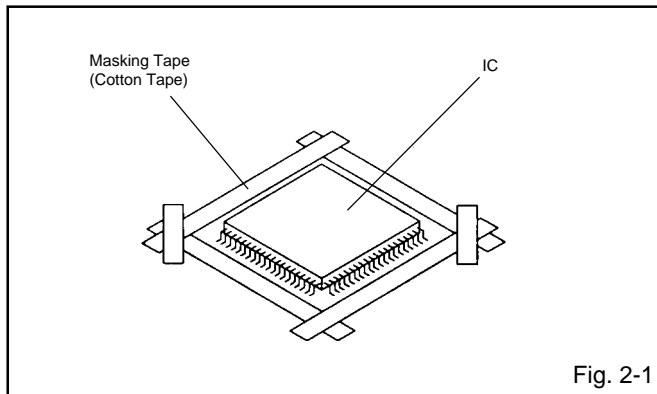

2. Heat the IC leads using a blower type IC desoldering machine. (Refer to Fig. 2-2.)

#### NOTE

Do not rotate or move the IC back and forth, until IC can move back and forth easily after desoldering the leads completely.

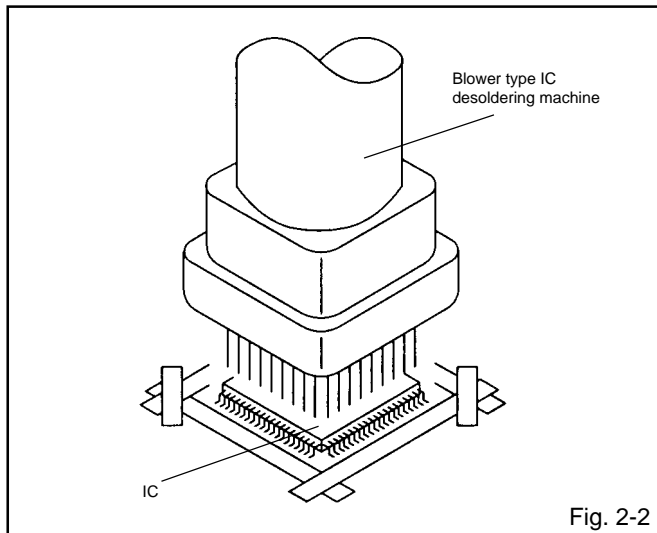

3. When IC starts moving back and forth easily after desoldering completely, pickup the corner of the IC using a tweezers and remove the IC by moving with the IC desoldering machine. (Refer to Fig. 2-3.)

#### NOTE

Some ICs on the PCB are affixed with glue, so be careful not to break or damage the foil of each IC leads or solder lands under the IC when removing it.

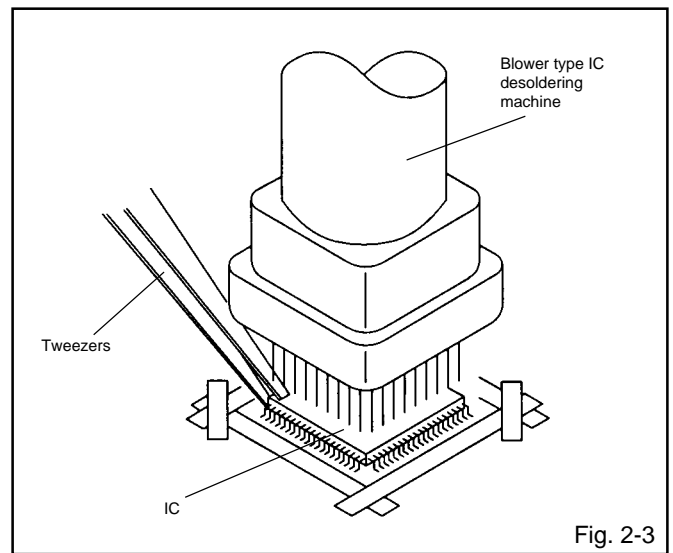

4. Peel off the Masking Tape.

5. Absorb the solder left on the pattern using the Braided Shield Wire. (Refer to Fig. 2-4.)

#### NOTE

Do not move the Braided Shield Wire in the vertical direction towards the IC pattern.

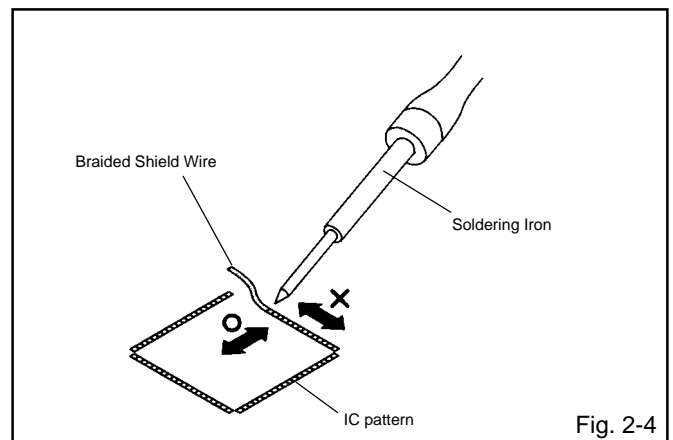

# DISASSEMBLY INSTRUCTIONS

## INSTALLATION

1. Take care of the polarity of new IC and then install the new IC fitting on the printed circuit pattern. Then solder each lead on the diagonal positions of IC temporarily. (Refer to Fig. 2-5.)

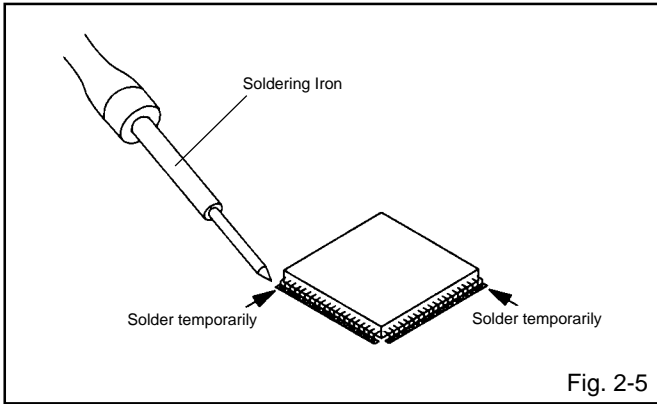

2. Supply the solder from the upper position of IC leads sliding to the lower position of the IC leads. (Refer to Fig. 2-6.)

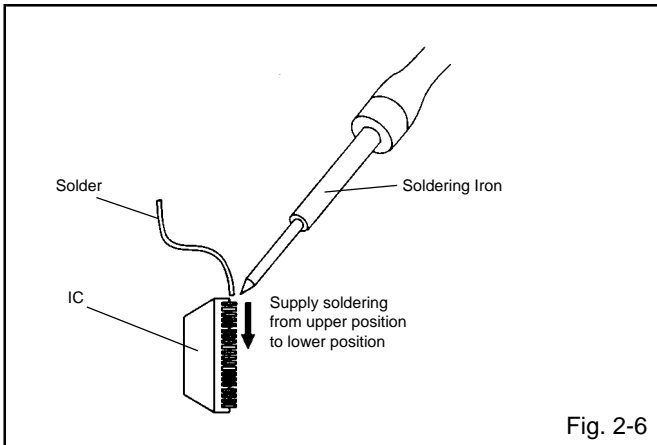

3. Absorb the solder left on the lead using the Braided Shield Wire. (Refer to Fig. 2-7.)

### NOTE

Do not absorb the solder to excess.

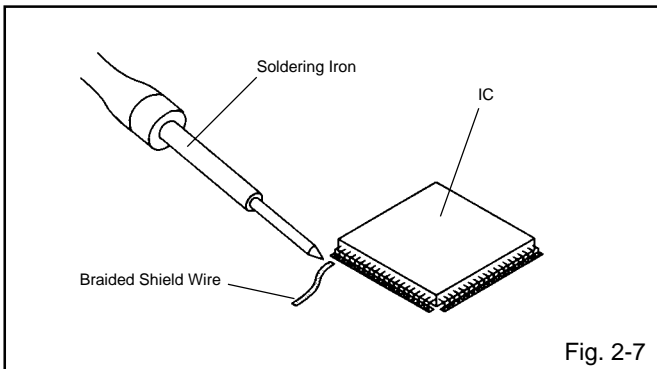

4. When bridge-soldering between terminals and/or the soldering amount are not enough, resolder using a Thin-tip Soldering Iron. (Refer to Fig. 2-8.)

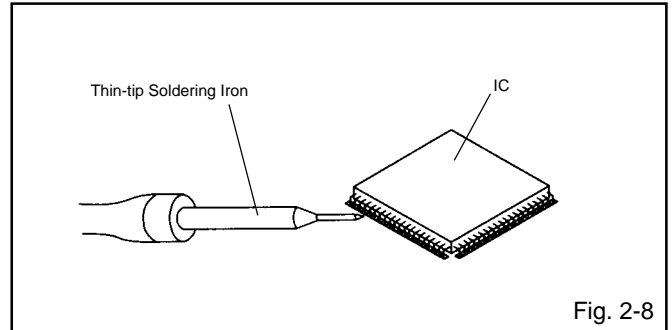

5. Finally, confirm the soldering status on four sides of the IC using a magnifying glass. Confirm that no abnormality is found on the soldering position and installation position of the parts around the IC. If some abnormality is found, correct by resoldering.

### NOTE

When the IC leads are bent during soldering and/or repairing, do not repair the bending of leads. If the bending of leads are repaired, the pattern may be damaged. So, always be sure to replace the IC in this case.

## SERVICE MODE LIST

This unit is provided with the following SERVICE MODES so you can repair, examine and adjust easily. To enter the Service Mode, press both set key and remote control key for more than 2 seconds.

Set Key	Remocon Key	Operations
VOL. (-) MIN	0	Releasing of V-CHIP PASSWORD.
VOL. (-) MIN	1	Initialization of factory data. NOTE: Do not use this for normal servicing. If you set factory initialization, the memories are reset such as the channel setting, and the POWER ON total hours.
VOL. (-) MIN	6	POWER ON total hours is displayed on the screen. Refer to the "CONFIRMATION OF HOURS USED".  Can be checked of the INITIAL DATA of MEMORY IC. Refer to the "WHEN REPLACING EEPROM (MEMORY) IC".
VOL. (-) MIN	9	Display of the Adjustment MENU on the screen. Refer to the "ELECTRICAL ADJUSTMENT" (On-Screen Display Adjustment).

## CONFIRMATION OF HOURS USED

POWER ON total hours can be checked on the screen. Total hours are displayed in 16 system of notation.

**NOTE: If you set factory initialization, the total hours is reset to "0".**

1. Set the VOLUME to minimum.
2. Press both VOL. DOWN button on the set and Channel button (6) on the remote control for more than 2 seconds.
3. After the confirmation of using hours, turn off the power.

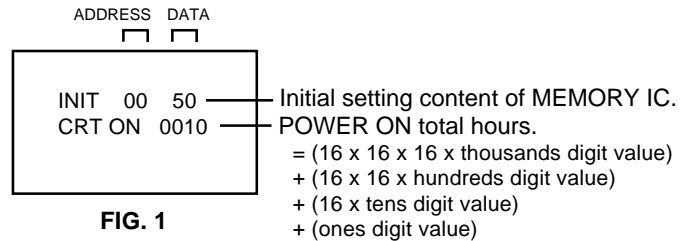

FIG. 1

## WHEN REPLACING EEPROM (MEMORY) IC

If a service repair is undertaken where it has been required to change the MEMORY IC, the following steps should be taken to ensure correct data settings while making reference to TABLE 1.

**NOTE: No need to set data after position INI 1F due to the adjustment value.**

INI	+0	+1	+2	+3	+4	+5	+6	+7	+8	+9	+A	+B	+C	+D	+E	+F
00	50	E8	0A	44	5E	B3	24	B7	*1	AC	0B	04	40	40	40	7F
10	50	00	00	00	03	00	00	99	3F	0F	0D	E2	A4	88	43	00

\*1

INI	USA	CANADA
08	3D	3C

Table 1

1. Enter DATA SET mode by setting VOLUME to minimum.
  2. Press both VOL. DOWN button on the set and Channel button (6) on the remote control for more than 2 seconds. ADDRESS and DATA should appear as FIG 1.
  3. ADDRESS is now selected and should "blink". Using the VOL. UP/DOWN button on the remote, step through the ADDRESS until required ADDRESS to be changed is reached.
  4. Press ENTER to select DATA. When DATA is selected, it will "blink".
  5. Again, step through the DATA using VOL. UP/DOWN button until required DATA value has been selected.
  6. Pressing ENTER will take you back to ADDRESS for further selection if necessary.
  7. Repeat steps 3 to 6 until all data has been checked.
  8. When satisfied correct DATA has been entered, turn POWER off (return to STANDBY MODE) to finish DATA input.  
**After the data input, set to the initializing of shipping.**
  9. Turn POWER on.
  10. Press both VOL. DOWN button on the set and Channel button (1) on the remote control for more than 2 seconds.
  11. After the finishing of the initializing of shipping, the unit will turn off automatically.
- The unit will now have the correct DATA for the new MEMORY IC.

# ELECTRICAL ADJUSTMENTS

## 1. ADJUSTMENT PROCEDURE

Read and perform these adjustments when repairing the circuits or replacing electrical parts or PCB assemblies.

### CAUTION

- Use an isolation transformer when performing any service on this chassis.
- Before removing the anode cap, discharge electricity because it contains high voltage.
- When removing a PCB or related component, after unfastening or changing a wire, be sure to put the wire back in its original position.
- When you exchange IC and Transistor with a heat sink, apply silicon grease on the contact section of the heat sink. Before applying new silicon grease, remove all the old silicon grease. (Old grease may cause damages to the IC and Transistor.)

Prepare the following measurement tools for electrical adjustments.

1. Oscilloscope
2. Digital Voltmeter
3. Multi-sound Generator
4. Pattern Generator

### On-Screen Display Adjustment

1. In the condition of NO indication on the screen. Press the VOL. DOWN button on the set and the Channel button (9) on the remote control for more than 2 second to appear the adjustment mode on the screen as shown in Fig. 1-1.

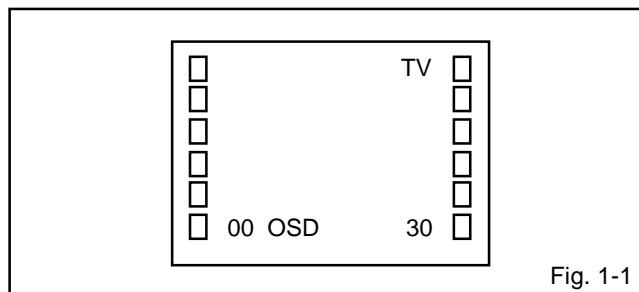

Fig. 1-1

2. Use the Channel UP/DOWN button or Channel button (0-9) on the remote control to select the options shown in Fig. 1-2.
3. Press the MENU button on the remote control to end the adjustments.

NO. FUNCTION	NO. FUNCTION
00 OSD H	18 CONT. MAX
01 CUT OFF	19 CONT. CENT
02 H. VCO	20 CONT. MIN
03 H. PHASE	21 COL. MAX
04 AFC GAIN	22 COL. CENT
05 V. SHIFT	23 COL. MIN
06 H. SIZE	24 TINT
07 V. SIZE	25 SHARPNESS
08 V. LINEARITY	26 CB DL
09 VS CORRECTION	27 CR DL
10 R DRIVE	28 CB PED
11 B DRIVE	29 CR PED
12 R BIAS	30 PARABOLA
13 G BIAS	31 CORNER
14 B BIAS	32 TRAPWZIUM
15 BRI. MAX	33 LEVEL
16 BRI. CENT	34 SEP.1
17 BRI. MIN	35 SEP.2

Fig. 1-2

## 2. BASIC ADJUSTMENTS

### 2-1: CONSTANT VOLTAGE

1. Place the set in AV MODE without signal.
2. Connect the digital voltmeter to the TP003.
3. Adjust the VR502 until the digital voltmeter is  $117 \pm 1V$ .

### 2-2: CUT OFF

1. Place the set in Aging Test for more than 15 minutes.
2. Using the remote control, set the brightness and contrast to normal position.
3. Activate the adjustment mode display of Fig. 1-1 and press the channel button (01) on the remote control to select "CUT OFF".
4. Adjust the Screen Volume until a dim raster is obtained.

### 2-3: WHITE BALANCE, WHITE BALANCE CS

NOTE: Adjust after performing CUT OFF adjustment.

1. Place the set in Aging Test for more than 15 minutes.
2. Receive the gray scale pattern from the Pattern Generator with Brust On.
3. Using the remote control, set the brightness and contrast to normal position.
4. Activate the adjustment mode display of Fig. 1-1 and press the channel button (12) on the remote control to select "R. BIAS".
5. Press the CH. UP/DOWN button on the remote control to select the "R. BIAS", "G. BIAS", "B. BIAS", "B. DRIVE" or "R. DRIVE".
6. Adjust the VOL. UP/DOWN button on the remote control to whiten the R. BIAS, G. BIAS, B. BIAS, B. DRIVE and R. DRIVE at each step tone sections equally.
7. Perform the above adjustments 5 and 6 until the white color is achieved.
8. Press the TV/VIDEO button on the remote control to set to the CS mode.
9. Receive the gray scale pattern from the Pattern Generator with Brust On.
10. If the picture is too much green. Activate the adjustment mode display of Fig. 1-1 and press the channel button (28) on the remote control to select "CB PED".
11. Adjust the VOL. UP/DOWN button on the remote control to select the step up.
12. If the picture is too much red. Activate the adjustment mode display of Fig. 1-1 and press the channel button (29) on the remote control to select "CR PED".
13. Adjust the VOL. UP/DOWN button on the remote control to select the step down.

### 2-4: FOCUS

1. Receive the monoscope pattern.
2. Turn the Focus Volume fully counterclockwise once.
3. Adjust the Focus Volume until picture is distinct.

# ELECTRICAL ADJUSTMENTS

## 2-5: HORIZONTAL SIZE

1. Receive the monoscope pattern.
2. Using the remote control, set the brightness and contrast to normal position.
3. Activate the adjustment mode display of **Fig. 1-1** and press the channel button (**06**) on the remote control to select "H. SIZE".
4. Press the VOL. UP/DOWN button on the remote control adjust the H.SIZE becomes 10 ~12%.

## 2-6: VERTICAL POSITION

1. Receive the monoscope pattern.
2. Using the remote control, set the brightness and contrast to normal position.
3. Adjust the **VR401** until the horizontal line becomes fit to the notch of the shadow mask. (Refer to **Fig. 2-1**)

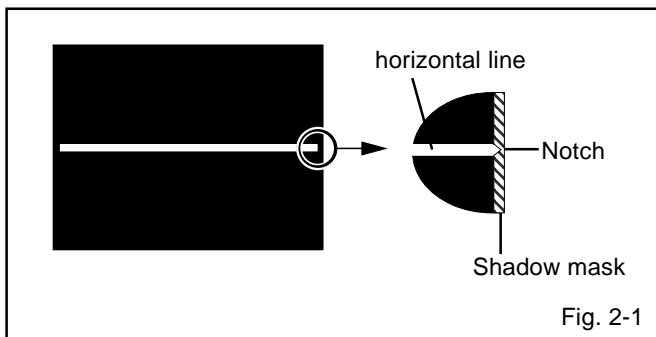

## 2-7: VERTICAL SIZE

1. Receive the monoscope pattern.
2. Using the remote control, set the brightness and contrast to normal position.
3. Activate the adjustment mode display of **Fig. 1-1** and press the channel button (**07**) on the remote control to select "V. SIZE".
4. Press the VOL. UP/DOWN button on the remote control until the SHIFT quantity of the OVER SCAN on upside and downside becomes  $9 \pm 3\%$ .

## 2-8: VERTICAL LINEARITY

**NOTE:** Adjust after performing adjustments in section 2-7. After the adjustment of Vertical Linearity, reconfirm the Vertical Position and Vertical Size adjustments.

1. Receive the monoscope pattern.
2. Using the remote control, set the brightness, contrast, to normal position.
3. Activate the adjustment mode display of **Fig. 1-1** and press the channel button (**08**) on the remote control to select "V. LINEARITY".
4. Press the VOL. UP/DOWN button on the remote control until the SHIFT quantity of the OVER SCAN on upside and downside becomes minimum.

## 2-9: TRAPEZIUM

1. Receive the cross hatch signal from the Pattern Generator.
2. Using the remote control, set the brightness and contrast to normal position.
3. Activate the adjustment mode display of **Fig. 1-1** and press the channel button (**32**) on the remote control to select "TRAPEZIUM".
4. Press the VOL. UP/DOWN button on the remote control until the both vertical lines of the screen become paralld.

## 2-10: HORIZONTAL PHASE

1. Receive the center cross signal from the Pattern Generator.
2. Using the remote control, set the brightness and contrast to normal position.
3. Activate the adjustment mode display of **Fig. 1-1** and press the channel button (**03**) on the remote control to select "H.PHASE".
4. Press the VOL. UP/DOWN button on the remote control until the SHIFT quantity of the OVER SCAN on right and left becomes minimum.

## 2-11: LEVEL

1. Connect the AC voltmeter to **pin 6** of **CP101**.
2. Activate the adjustment mode display of **Fig. 1-1** and press the channel button (**33**) on the remote control to select "LEVEL".
3. Press the VOL. UP/DOWN button on the remote control until the AC voltmeter is  $85 \pm 2\text{mV}$ .

## 2-12: SEPARATION 1, 2

Please do the method (1) or method (2) adjustment.

### Method (1)

1. Set the multi-sound signal generator for each different L-ch and R-ch frequency (Ex. L-ch=400Hz, R-ch=2KHz) and receive the RF.
2. Connect the oscilloscope to the Audio Out Jack.
3. Activate the adjustment mode display of **Fig. 1-1** and press the channel button (**34**) on the remote control to select "SEP 1".
4. Press the VOL. UP/DOWN button on the remote control to adjust it until the audio output wave becomes a fine sine wave.
5. Press the CH UP button once the set to "SEP 2" mode. Then perform the above adjustment 4.

# ELECTRICAL ADJUSTMENTS

## Method (2)

1. Set the multi-sound signal generator L-ch=1KHz, R-ch =Non input and receive the RF.
2. Connect the oscilloscope to the Audio Out Jack (R-ch).
3. Press the AUDIO SELECT button on the remote control to set to the stereo mode.
4. Activate the adjustment mode display of **Fig. 1-1** and press the channel button (**34**) on the remote control to select "SEP 1".
5. Press the VOL. UP/DOWN button on the remote control to adjust it until the R-ch output becomes minimum.
6. Set the multi-sound signal generator L-ch=Non input, R-ch=1KHz and receive the RF.
7. Connect the oscilloscope to the Audio Out Jack (L-ch).
8. Activate the adjustment mode display of **Fig. 1-1** and press the channel button (**35**) on the remote control to select "SEP 2".
9. Press the VOL. UP/DOWN button on the remote control to adjust it until the L-ch output becomes minimum. The output difference of the between with Filter and without Filter should be more than 25db for both L and R.

## 2-13: OSD POSITION

1. Activate the adjustment mode display of **Fig. 1-1**.
2. Press the VOL. UP/DOWN button on the remote control until the difference of A and B becomes minimum. (**Refer to Fig. 2-2**)

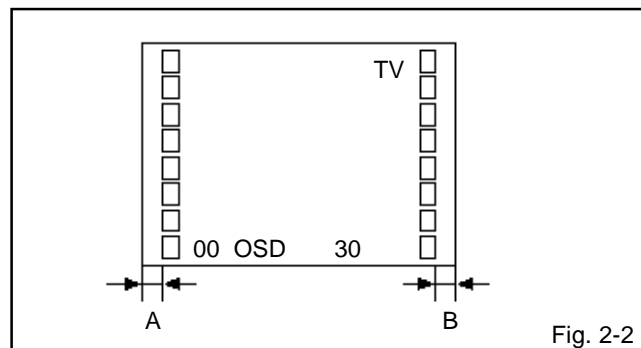

## 2-14: BRIGHT CENT

1. Receive the monoscope pattern. (RF Input)
2. Using the remote control, set the brightness and contrast to normal position.
3. Activate the adjustment mode display of **Fig. 1-1** and press the channel button (**16**) on the remote control to select "BRI CENT".
4. Press the VOL. UP/DOWN button on the remote control until the white 10% is starting to be visible.
5. Receive the monoscope pattern. (Audio Video Input)
6. Press the TV/VIDEO button on the remote control to set to the AV mode. Then perform the above adjustments 2~4.
7. Press the TV/VIDEO button on the remote control to set to the CS mode.
8. Activate the adjustment mode display of **Fig. 1-1** and press the channel button (**16**) on the remote control to select "BRI CENT".
9. Press the VOL. UP/DOWN button on the remote control until the brightness step No. becomes "80".

## 2-15: COLOR CENT

1. Receive the color bar pattern. (RF Input)
2. Using the remote control, set the brightness, contrast, color and tint to normal position.
3. Connect the oscilloscope to TP804.
4. Activate the adjustment mode display of **Fig. 1-1** and press the channel button (**22**) on the remote control to select "COLOR CENT".
5. Adjust the VOLTS RANGE VARIABLE knob of the oscilloscope until the range between white 100% and 0% is set to 4 scales on the screen of the oscilloscope.
6. Press the VOL. UP/DOWN button on the remote control until the red color level is adjusted to  $120 \pm 10\%$  of the white level. (**Refer to Fig. 2-3**)
7. Receive the video color bar pattern. (Audio Video Input)
8. Set to the AV mode. Then perform the above adjustments 2~6.
9. Press the TV/VIDEO button on the remote control to set to the CS mode. Then perform the above adjustments 2~4.
10. Press the VOL. UP/DOWN button on the remote control until the color step No. becomes "68".

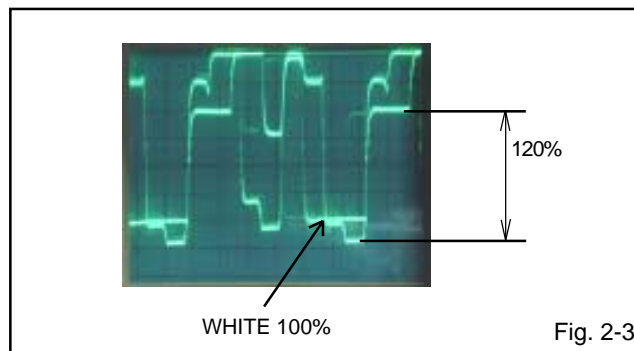

# ELECTRICAL ADJUSTMENTS

## 2-16: TINT

1. Receive the color bar pattern. (RF Input)
2. Using the remote control, set the brightness, contrast, color and tint to normal position.
3. Connect the oscilloscope to TP806.
4. Activate the adjustment mode display of **Fig. 1-1** and press the channel button (**24**) on the remote control to select "TINT".
5. Press the VOL. UP/DOWN button on the remote control until the section "A" becomes as straight line.  
(Refer to **Fig. 2-4**)
6. Receive the video color bar pattern. (Audio Video Input)
7. Set to the AV mode. Then perform the above adjustments 2~5.
8. Press the TV/VIDEO button on the remote control to set to the CS mode. Then perform the above adjustments 2~4.
9. Press the VOL. UP/DOWN button on the remote control until the tint step No. becomes "54".

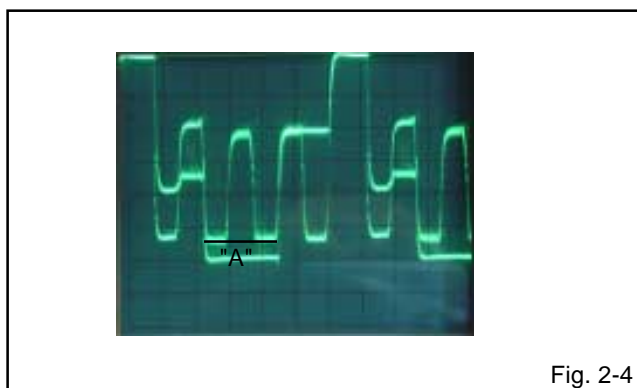

Fig. 2-4

## 2-17: CONTRAST MAX

1. Activate the adjustment mode display of **Fig. 1-1** and press the channel button (**18**) on the remote control to select "CONT. MAX".
2. Press the VOL. UP/DOWN button on the remote control until the contrast step No. becomes "95".
3. Receive a broadcast and check if the picture is normal.
4. Press the TV/VIDEO button on the remote control to set to the AV mode. Then perform the above adjustments 1~3.
5. Press the TV/VIDEO button on the remote control to set to the CS mode. Then perform the above adjustments 1~3.

## 2-18: PARABOLA CORR

1. Receive the cross hatch signal from the Pattern Generator.
2. Using the remote control, set the brightness and contrast to normal position.
3. Activate the adjustment mode display of **Fig. 1-1** and press the channel button (**30**) on the remote control to select "PARABOLA".
4. Press the VOL. UP/DOWN button on the remote control until the right and left vertical lines are straight.
5. In the case the right and left vertical lines are not straight, Please Activate the adjustment mode display of **Fig. 1-1** and press the channel button (**31**) on the remote control to select "CORNER".
6. Press the VOL. UP/DOWN button on the remote control until the right and left vertical lines are straight.

## 2-19: Confirmation of Fixed Value (Step No.)

Please check if the fixed values of the each adjustment items are set correctly referring below.

NO.	FUNCTION	RF	AV	CS
02	H.VCO	03	03	03
04	AFC GAIN	07	07	07
05	V.SHIFT	02	02	02
09	VS.CORRECTION	36	36	36
15	BRI.MAX	160	160	160
17	BRI.MIN	50	50	50
19	CONT.CENT	64	64	64
20	CONT.MIN	15	15	15
21	COL.MAX	90	90	90
23	COL.MIN	00	00	00
25	SHARPNESS	40	40	40
26	CB DL	00	00	00
27	CR DL	00	00	00

# ELECTRICAL ADJUSTMENTS

## 3. PURITY AND CONVERGENCE ADJUSTMENTS

### NOTE

1. Turn the unit on and let it warm up for at least 30 minutes before performing the following adjustments.
2. Place the CRT surface facing east or west to reduce the terrestrial magnetism.
3. Turn ON the unit and demagnetize with a Degauss Coil.

### 3-1: STATIC CONVERGENCE (ROUGH ADJUSTMENT)

1. Tighten the screw for the magnet. Refer to the adjusted CRT for the position. **(Refer to Fig. 3-1)**  
If the deflection yoke and magnet are in one body, untighten the screw for the body.
2. Receive the green raster pattern from the color bar generator.
3. Slide the deflection yoke until it touches the funnel side of the CRT.
4. Adjust center of screen to green, with red and blue on the sides, using the pair of purity magnets.
5. Switch the color bar generator from the green raster pattern to the crosshatch pattern.
6. Combine red and blue of the 3 color crosshatch pattern on the center of the screen by adjusting the pair of 4 pole magnets.
7. Combine red/blue (magenta) and green by adjusting the pair of 6 pole magnets.
8. Adjust the crosshatch pattern to change to white by repeating steps 6 and 7.

### 3-2: PURITY

#### NOTE

Adjust after performing adjustments in section 3-1.

1. Receive the green raster pattern from color bar generator.
2. Adjust the pair of purity magnets to center the color on the screen.  
Adjust the pair of purity magnets so the color at the ends are equally wide.
3. Move the deflection yoke backward (to neck side) slowly, and stop it at the position when the whole screen is green.
4. Confirm red and blue color.  
Adjust the slant of the deflection yoke while watching the screen, then tighten the fixing screw.

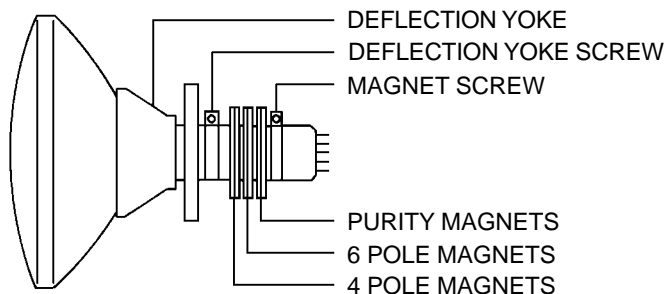

Fig. 3-1

### 3-3: STATIC CONVERGENCE

#### NOTE

Adjust after performing adjustments in section 3-2.

1. Receive the crosshatch pattern from the color bar generator.
2. Combine red and blue of the 3 color crosshatch pattern on the center of the screen by adjusting the pair of 4 pole magnets.
3. Combine red/blue (magenta) and green by adjusting the pair of 6 pole magnets.

### 3-4: DYNAMIC CONVERGENCE

#### NOTE

Adjust after performing adjustments in section 3-3.

1. Adjust the differences around the screen by moving the deflection yoke upward/downward and right/left. **(Refer to Fig. 3-2-a)**
2. Insert three wedges between the deflection yoke and CRT funnel to fix the deflection yoke. **(Refer to Fig. 3-2-b)**

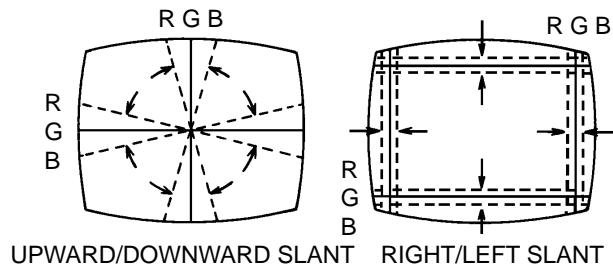
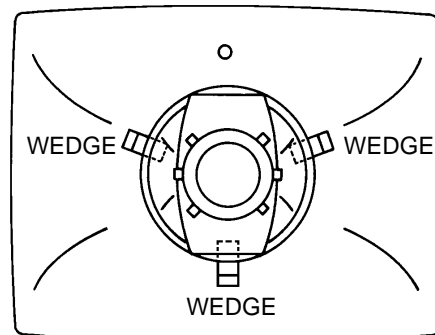

Fig. 3-2-a



WEDGE POSITION

Fig. 3-2-b

# ELECTRICAL ADJUSTMENTS

## 4. ELECTRICAL ADJUSTMENT PARTS LOCATION GUIDE (WIRING CONNECTION)

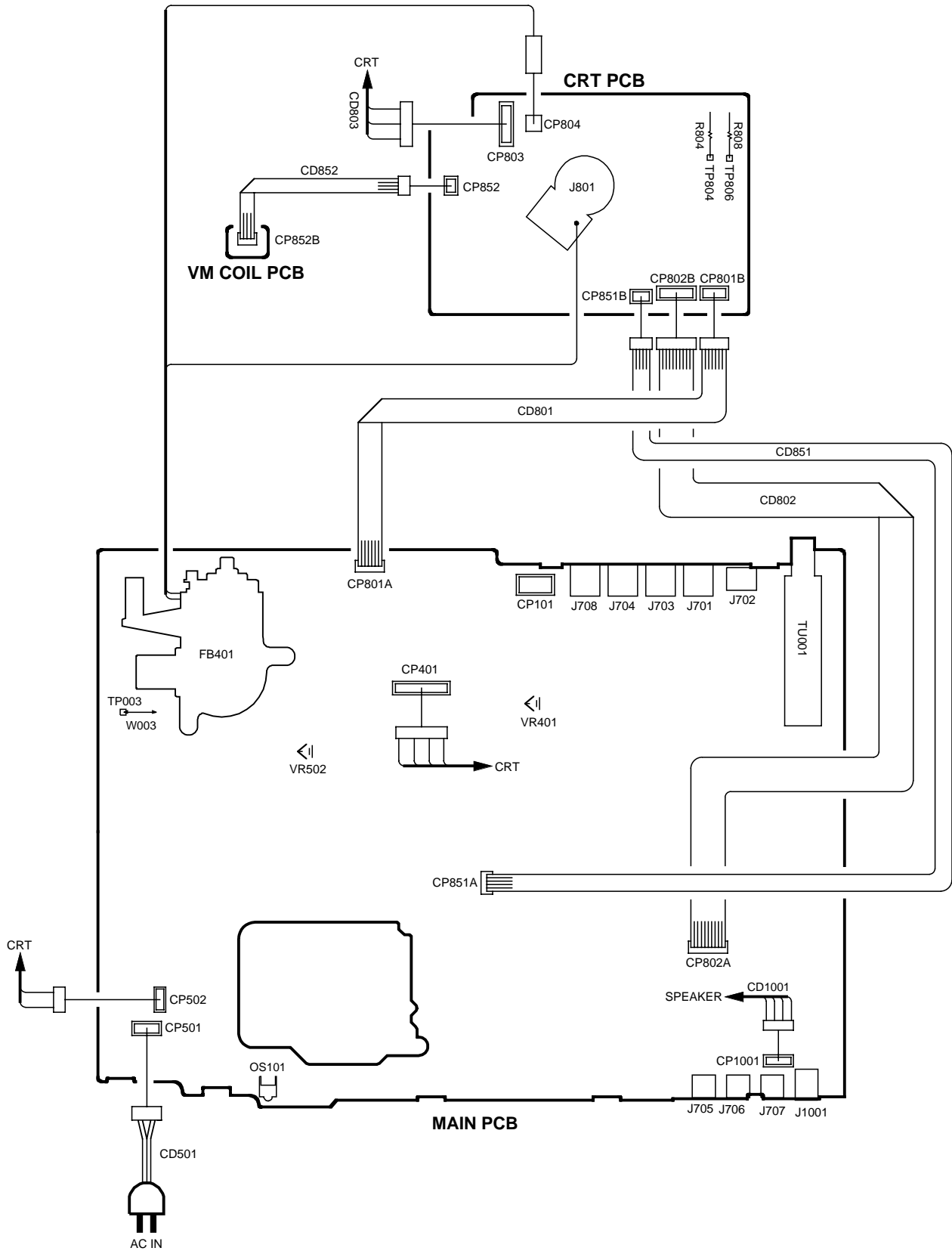

# BLOCK DIAGRAM

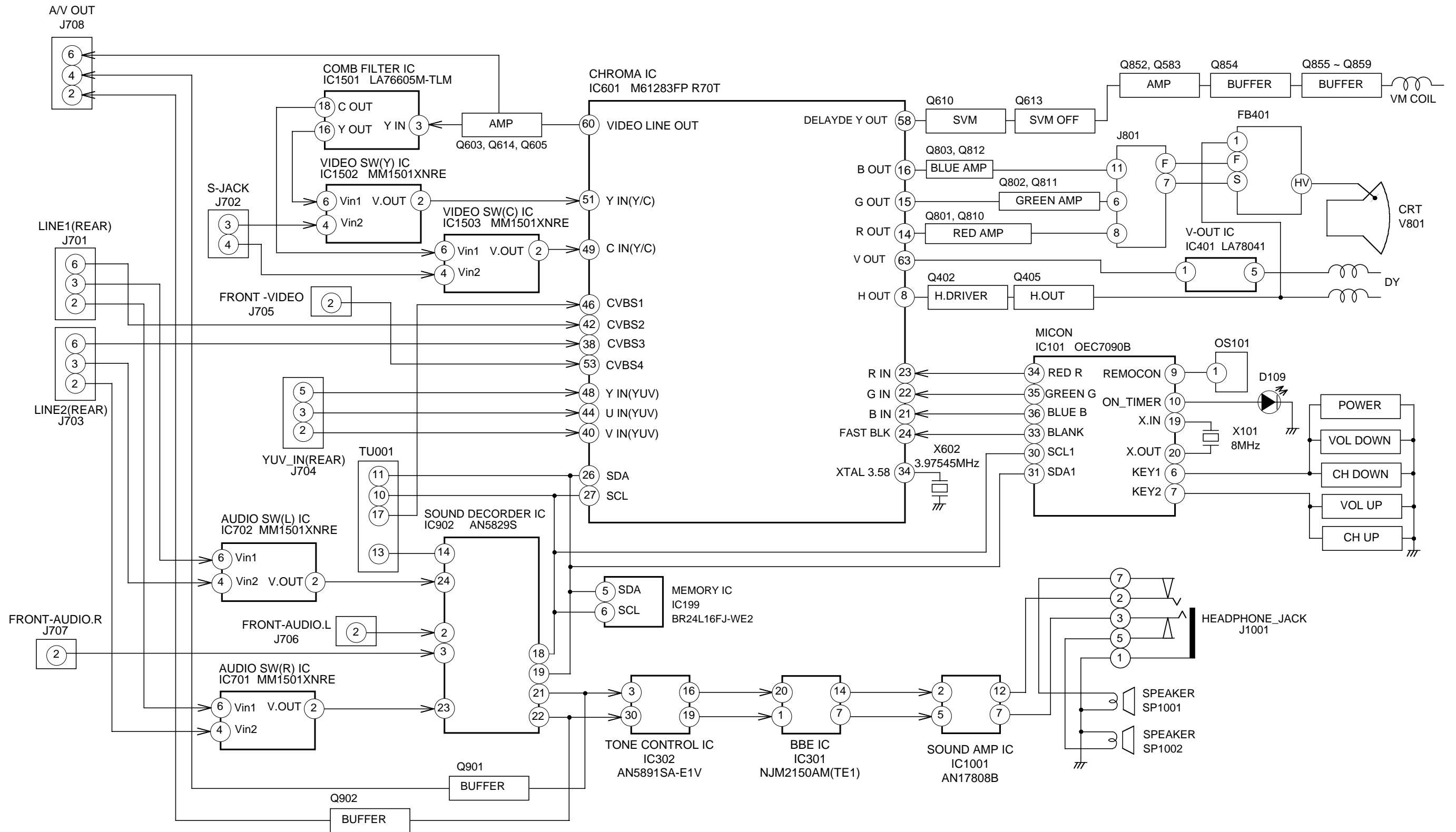



PRINTED CIRCUIT BOARDS  
MAIN (CHIP MOUNTED PARTS)  
SOLDER SIDE

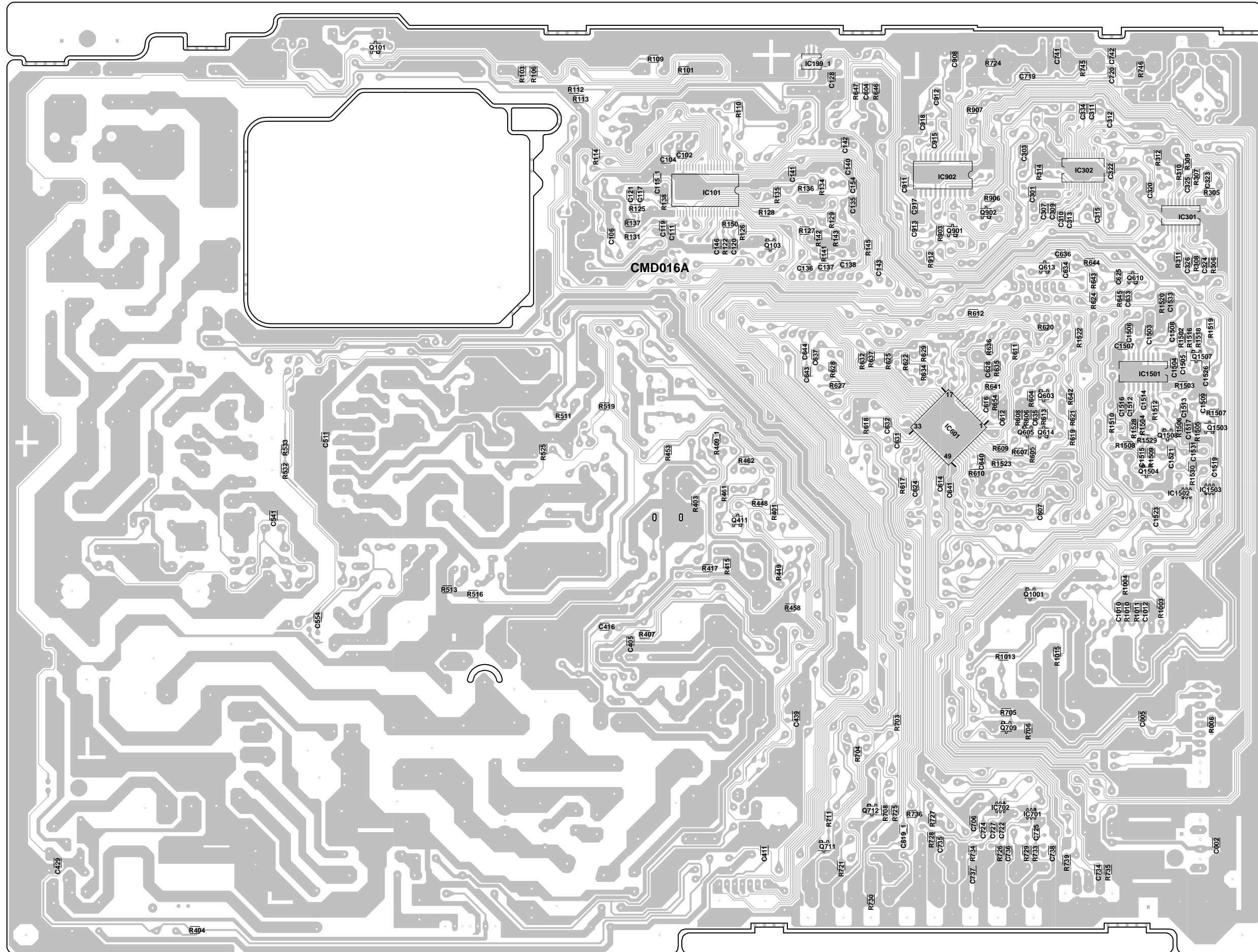

PRINTED CIRCUIT BOARDS  
 CRT/VM COIL  
 SOLDER SIDE

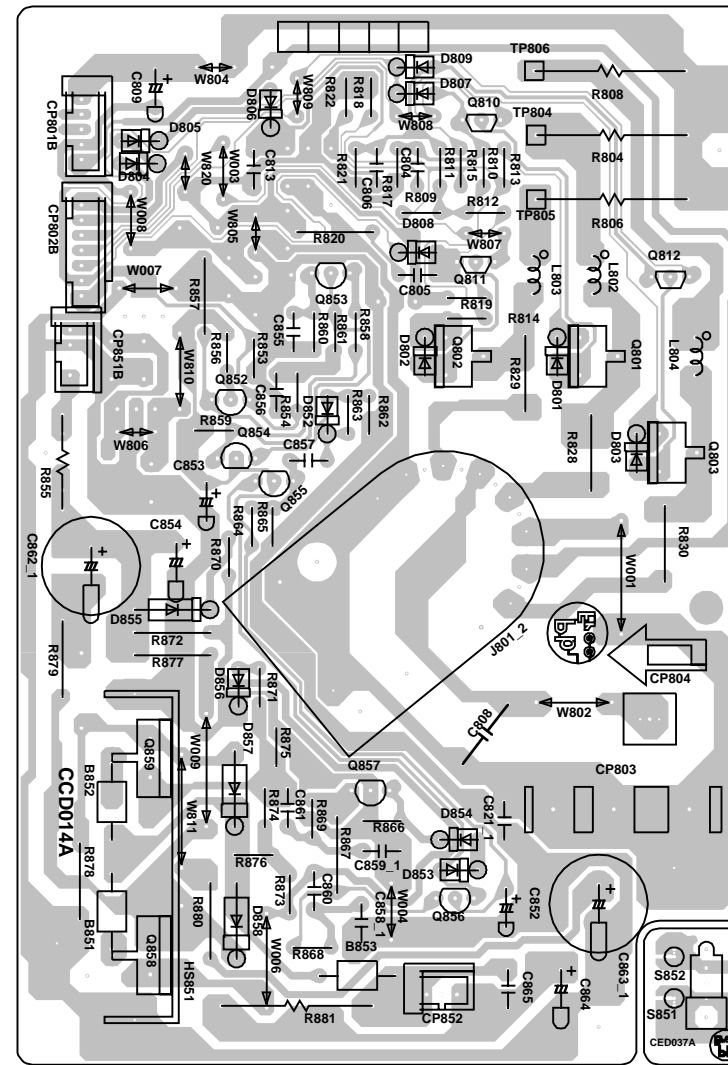

# MICON SCHEMATIC DIAGRAM (MAIN PCB)

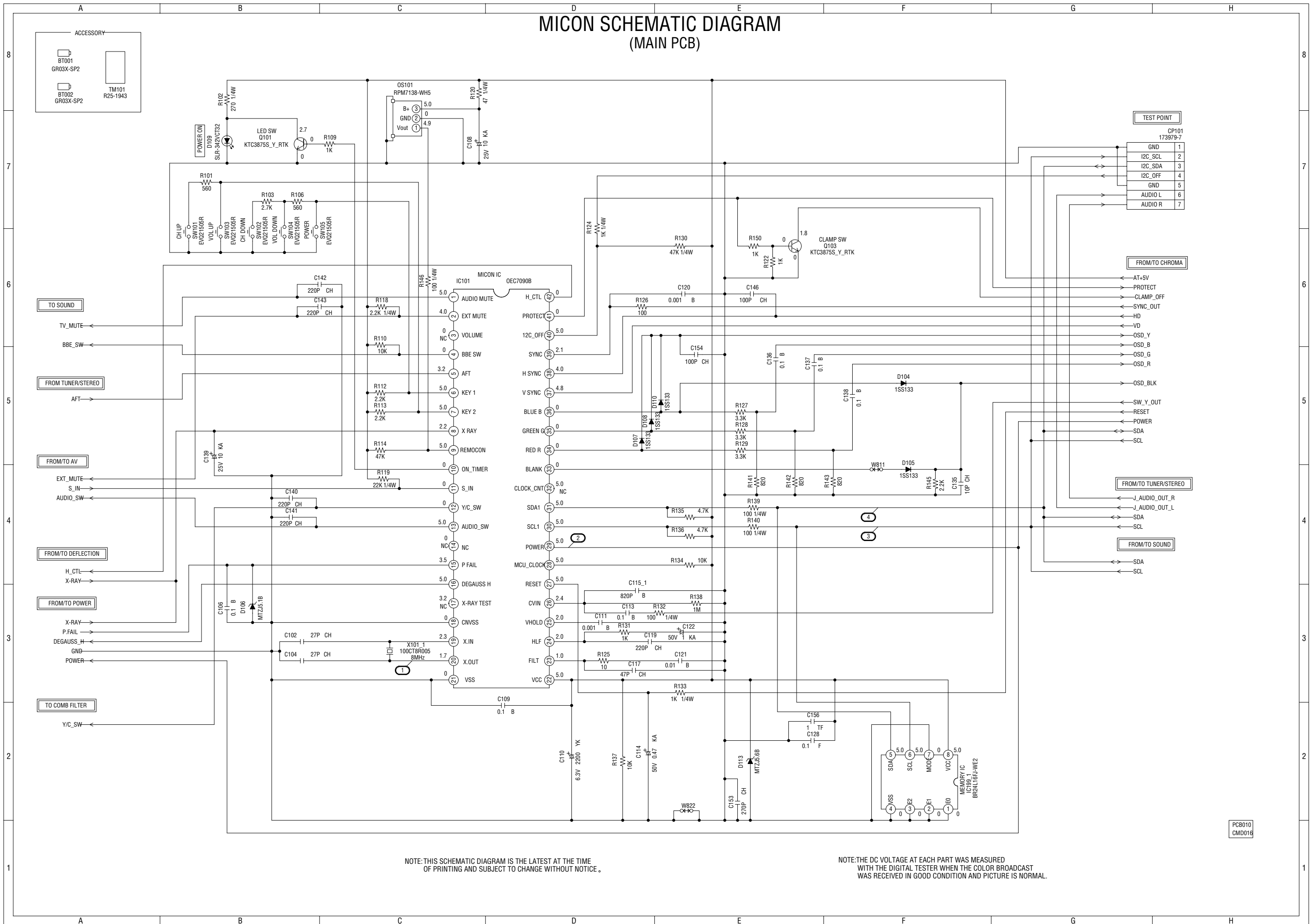

NOTE: THIS SCHEMATIC DIAGRAM IS THE LATEST AT THE TIME OF PRINTING AND SUBJECT TO CHANGE WITHOUT NOTICE.

NOTE: THE DC VOLTAGE AT EACH PART WAS MEASURED WITH THE DIGITAL TESTER WHEN THE COLOR BROADCAST WAS RECEIVED IN GOOD CONDITION AND PICTURE IS NORMAL.

PCB010  
CMD016

# CHROMA SCHEMATIC DIAGRAM (MAIN PCB)

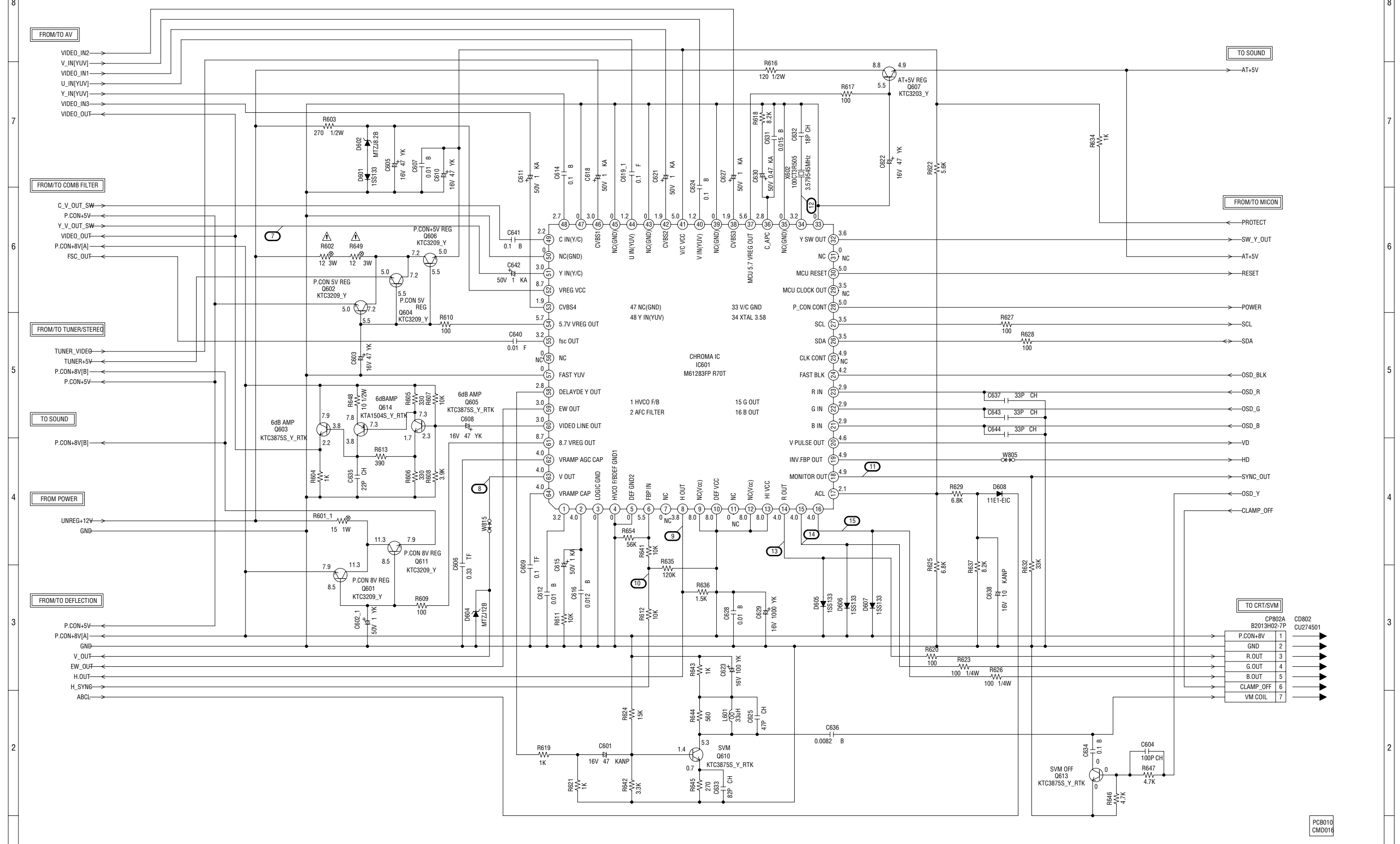

NOTE: THIS SCHEMATIC DIAGRAM IS THE LATEST AT THE TIME OF PRINTING AND SUBJECT TO CHANGE WITHOUT NOTICE.

NOTE: THE DC VOLTAGE AT EACH PART WAS MEASURED WITH THE DIGITAL TESTER WHEN THE COLOR BROADCAST WAS RECEIVED IN GOOD CONDITION AND PICTURE IS NORMAL.

**ATTENTION** - LES PIÈCES RÉPARÉES PAR UN ÉTANT DANGEREUSES AU POINT DE VUE SÉCURITÉ N'UTILISER QUE CELLES DÉCRITES DANS LA NOMENCLATURE DES PIÈCES.

**CAUTION** - SINCE THESE PARTS MARKED BY ARE CRITICAL FOR SAFETY, USE ONES DESCRIBED IN PARTS LIST ONLY.

PCB010  
CMD016

# DEFLECTION SCHEMATIC DIAGRAM (MAIN PCB)

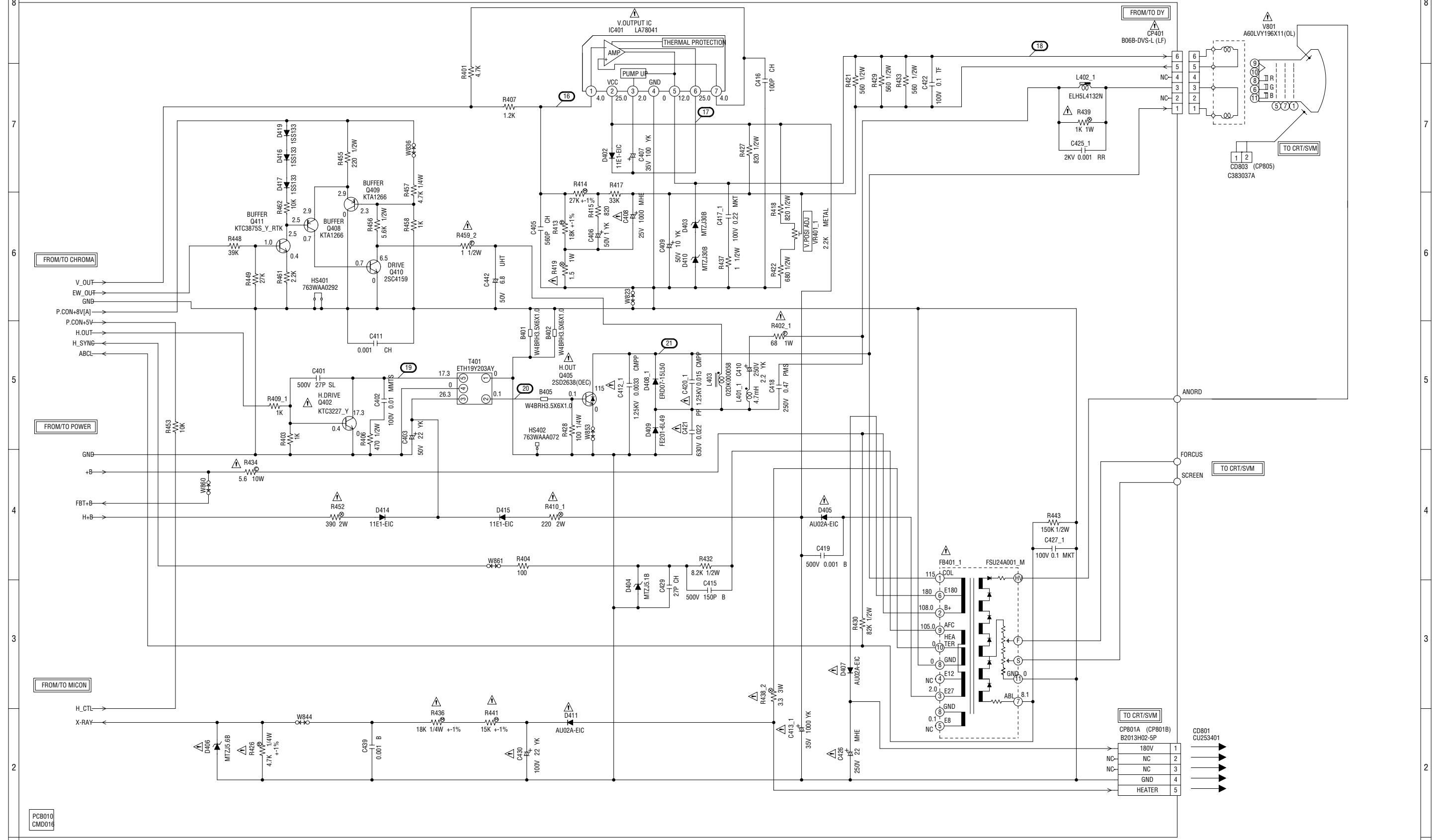

NOTE: THIS SCHEMATIC DIAGRAM IS THE LATEST AT THE TIME OF PRINTING AND SUBJECT TO CHANGE WITHOUT NOTICE.

NOTE: THE DC VOLTAGE AT EACH PART WAS MEASURED WITH THE DIGITAL TESTER WHEN THE COLOR BROADCAST WAS RECEIVED IN GOOD CONDITION AND PICTURE IS NORMAL.

NOTE: THE RESISTOR MARKED F IS FUSE RESISTOR. THE ALUMI ELECTROLYTIC CAPACITOR MARKED NP IS NON POLAR ONE.

ATTENTION: LES PIÈCES RÉPARÉES PAR UN  $\Delta$  ÉTANT DANGEREUSES AN POINT DE VUE SECURITE N'UTILISER QUE CELLS DECRITES DANS LA NOMENCLATURE DES PIÈCES.

CAUTION: SINCE THESE PARTS MARKED BY  $\Delta$  ARE CRITICAL FOR SAFETY, USE ONES DESCRIBED IN PARTS LIST ONLY.

# POWER SCHEMATIC DIAGRAM (MAIN PCB)

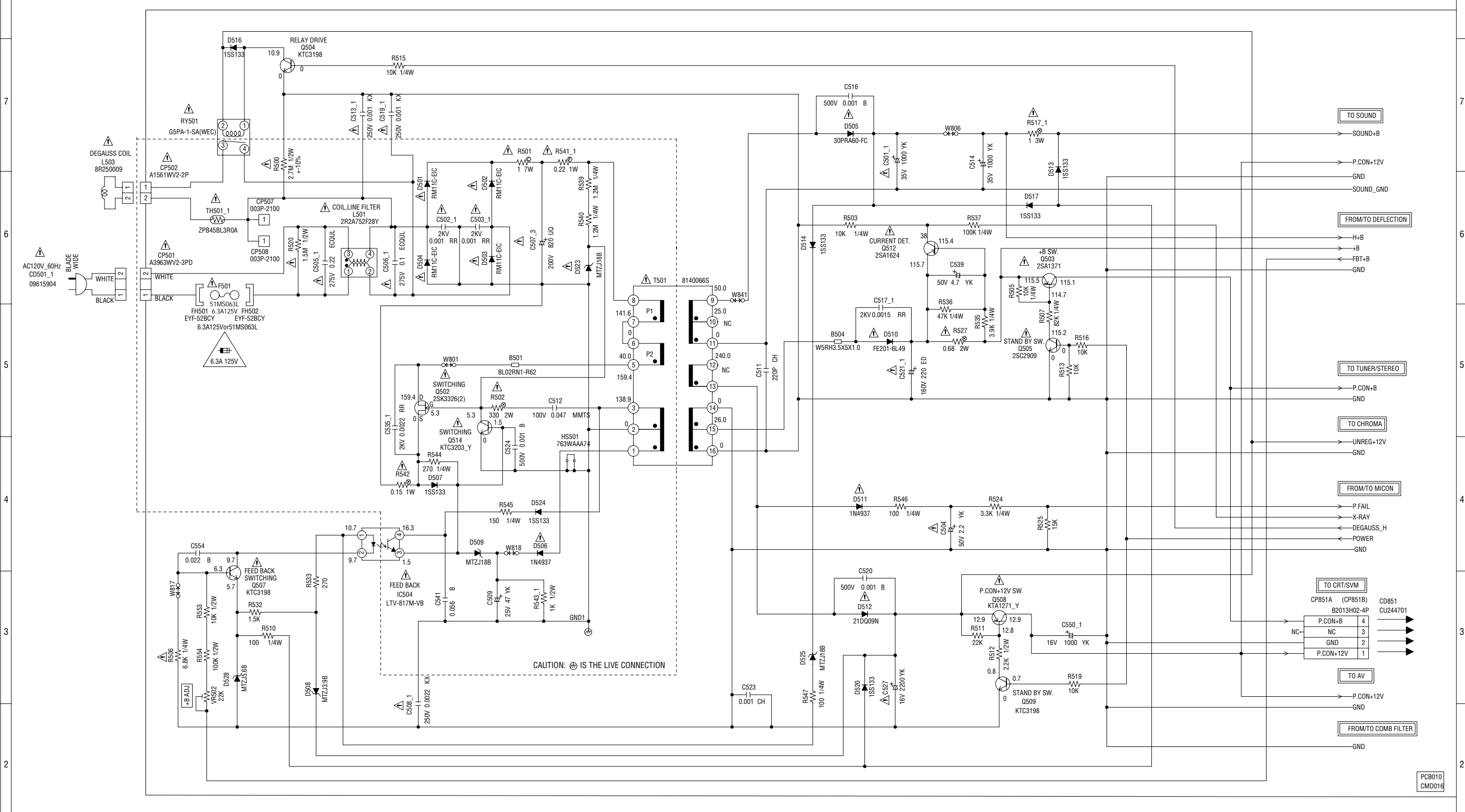

**CAUTION:** FOR CONTINUED PROTECTION AGAINST FIRE HAZARD, REPLACE ONLY WITH THE SAME TYPE FUSE 6.3A 125V(F501)

**ATTENTION:** POUR UNE PROTECTION CONTINUE LES RISQUES D'INCENDIE N'UTILISER QUE DES FUSIBLE DE MEME TYPE 6.3A 125V(F501)

**NOTE:** THIS SCHEMATIC DIAGRAM IS THE LATEST AT THE TIME OF PRINTING AND SUBJECT TO CHANGE WITHOUT NOTICE.

**NOTE:** THE DC VOLTAGE AT EACH PART WAS MEASURED WITH THE DIGITAL TESTER WHEN THE COLOR BROADCAST WAS RECEIVED IN GOOD CONDITION AND PICTURE IS NORMAL.

**NOTE:** THE RESISTOR MARKED F IS FUSE RESISTOR. THE ALUMI ELECTROLYTIC CAPACITOR MARKED NP IS NON POLAR ONE.

**ATTENTION:** LES PIECES REPARÉES PAR UN ETANT DANGEREUSES AN POINT DE VUE SECURITE N'UTILISER QUE CELLS DECRITES DANS LA NOMENCLATURE DES PIECES.

**CAUTION:** SINCE THESE PARTS MARKED BY ARE CRITICAL FOR SAFETY, USE ONES DESCRIBED IN PARTS LIST ONLY.

# SOUND SCHEMATIC DIAGRAM (MAIN PCB)

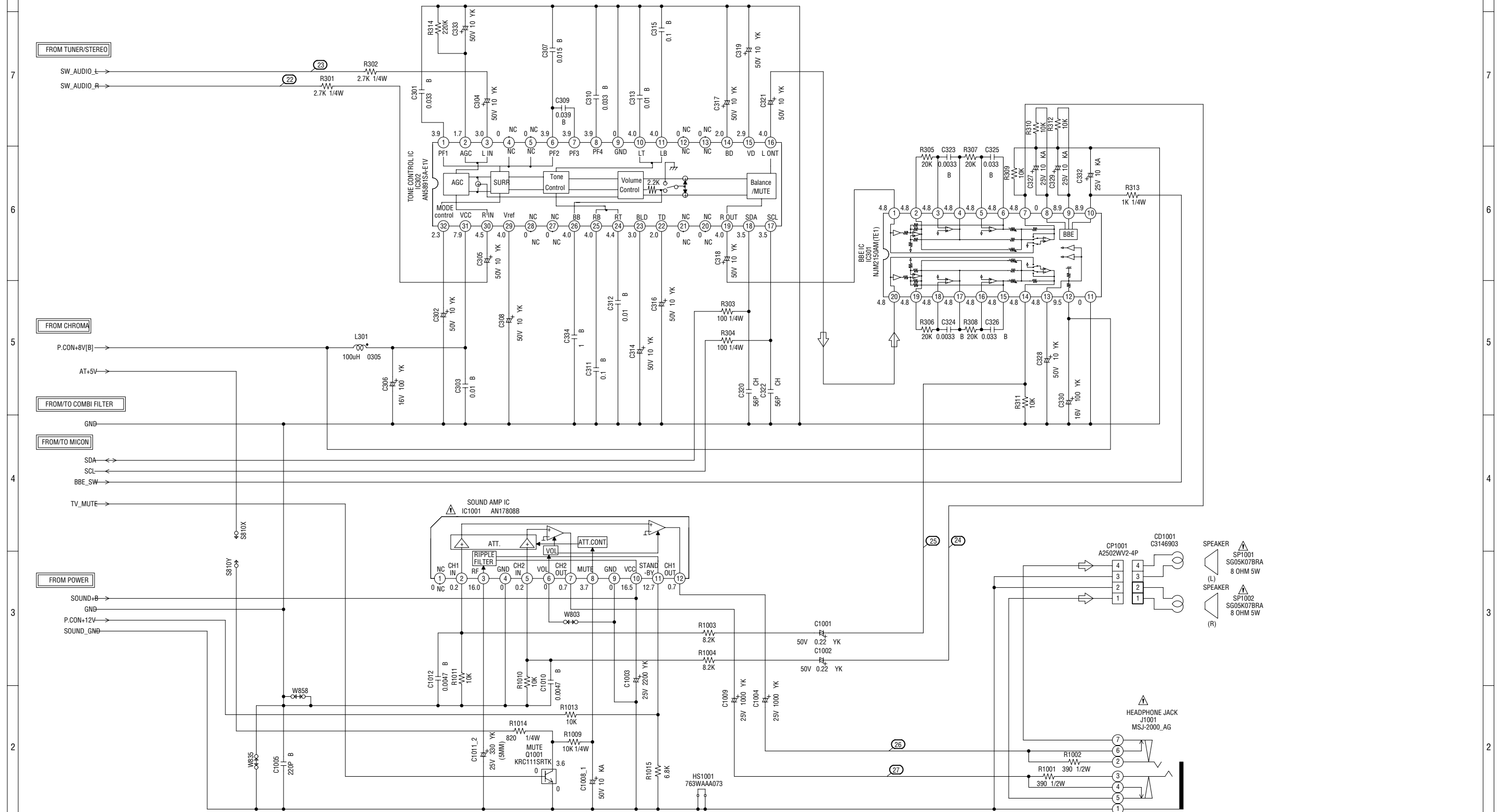

NOTE: THIS SCHEMATIC DIAGRAM IS THE LATEST AT THE TIME OF PRINTING AND SUBJECT TO CHANGE WITHOUT NOTICE.

NOTE: THE DC VOLTAGE AT EACH PART WAS MEASURED WITH THE DIGITAL TESTER WHEN THE COLOR BROADCAST WAS RECEIVED IN GOOD CONDITION AND PICTURE IS NORMAL.

**ATTENTION:** LES PIÈCES RÉPARÉES PAR UN ÉTANT DANGEREUSES AU POINT DE VUE SÉCURITÉ N'UTILISER QUE CELLES DÉCRITES DANS LA NOMENCLATURE DES PIÈCES.

**CAUTION:** SINCE THESE PARTS MARKED BY ARE CRITICAL FOR SAFETY, USE ONES DESCRIBED IN PARTS LIST ONLY.

CAUTION: DIGITAL TRANSISTOR

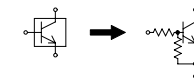

PCB010  
CMD016

# TUNER/STEREO SCHEMATIC DIAGRAM (MAIN PCB)

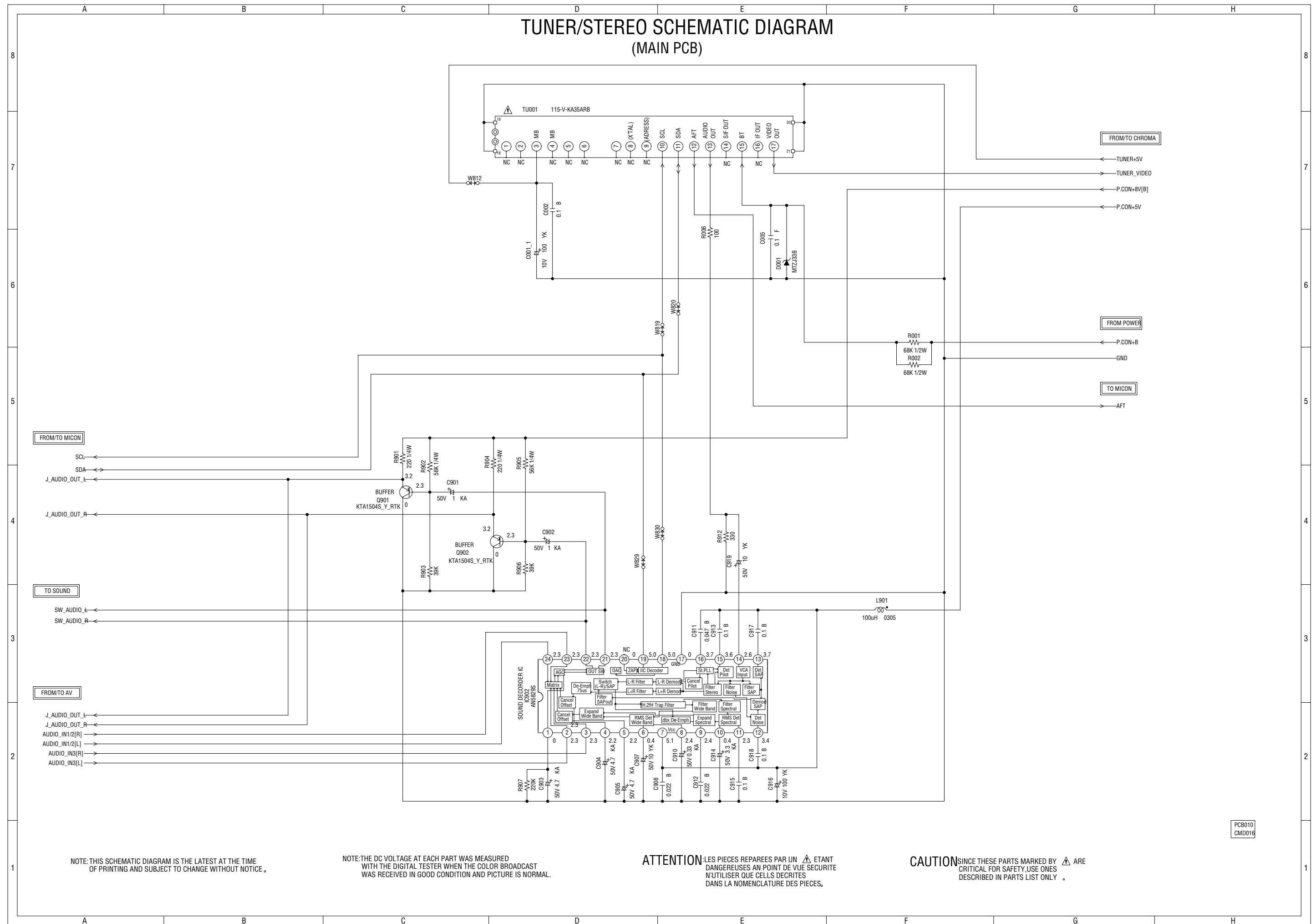

NOTE: THIS SCHEMATIC DIAGRAM IS THE LATEST AT THE TIME OF PRINTING AND SUBJECT TO CHANGE WITHOUT NOTICE.

NOTE: THE DC VOLTAGE AT EACH PART WAS MEASURED WITH THE DIGITAL TESTER WHEN THE COLOR BROADCAST WAS RECEIVED IN GOOD CONDITION AND PICTURE IS NORMAL.

**ATTENTION:** LES PIÈCES RÉPARÉES PAR UN ÉTANT DANGEREUSES AN POINT DE VUE SECURITE N'UTILISER QUE CELLS DECRITES DANS LA NOMENCLATURE DES PIÈCES.

**CAUTION:** SINCE THESE PARTS MARKED BY ARE CRITICAL FOR SAFETY, USE ONES DESCRIBED IN PARTS LIST ONLY.

PCB010  
CMD016

# AV SCHEMATIC DIAGRAM (MAIN PCB)

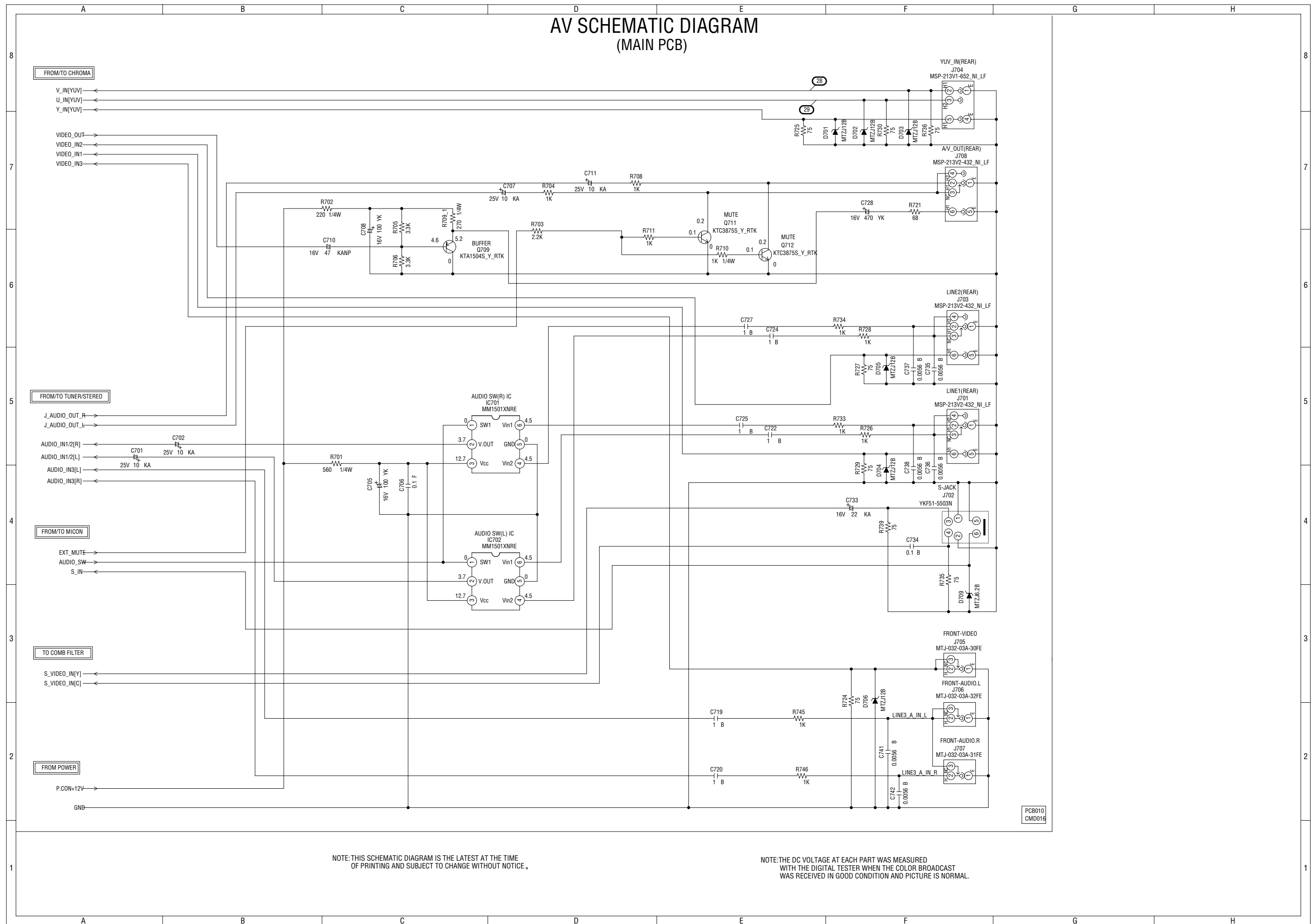

NOTE: THIS SCHEMATIC DIAGRAM IS THE LATEST AT THE TIME OF PRINTING AND SUBJECT TO CHANGE WITHOUT NOTICE.

NOTE: THE DC VOLTAGE AT EACH PART WAS MEASURED WITH THE DIGITAL TESTER WHEN THE COLOR BROADCAST WAS RECEIVED IN GOOD CONDITION AND PICTURE IS NORMAL.

PCB010  
CMD016

# COMB FILTER SCHEMATIC DIAGRAM (MAIN PCB)

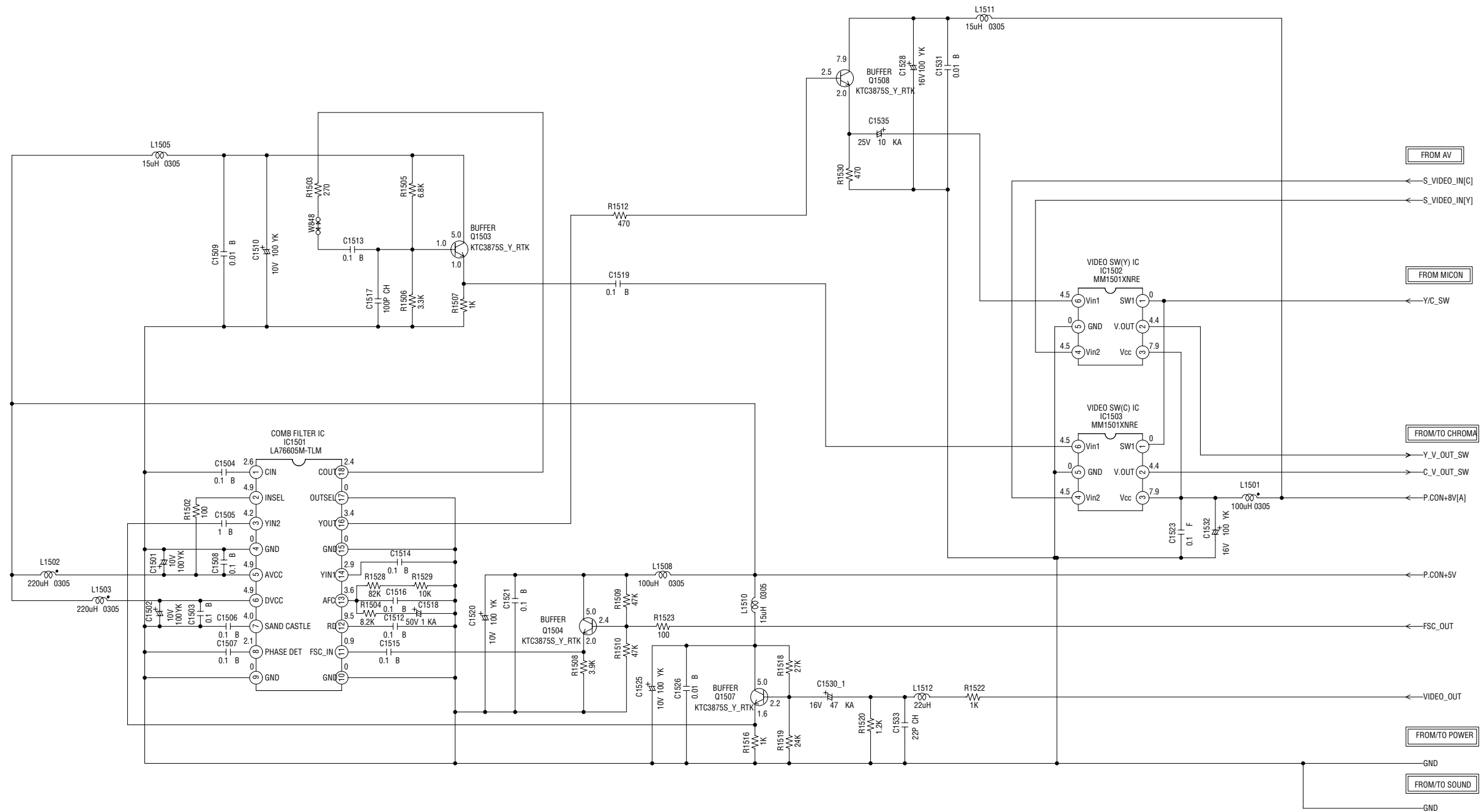

NOTE: THIS SCHEMATIC DIAGRAM IS THE LATEST AT THE TIME OF PRINTING AND SUBJECT TO CHANGE WITHOUT NOTICE.

NOTE: THE DC VOLTAGE AT EACH PART WAS MEASURED WITH THE DIGITAL TESTER WHEN THE COLOR BROADCAST WAS RECEIVED IN GOOD CONDITION AND PICTURE IS NORMAL.

PCB010  
CMD016

# CRT/SVM SCHEMATIC DIAGRAM (CRT PCB)

## CRT BLOCK

## SVM BLOCK

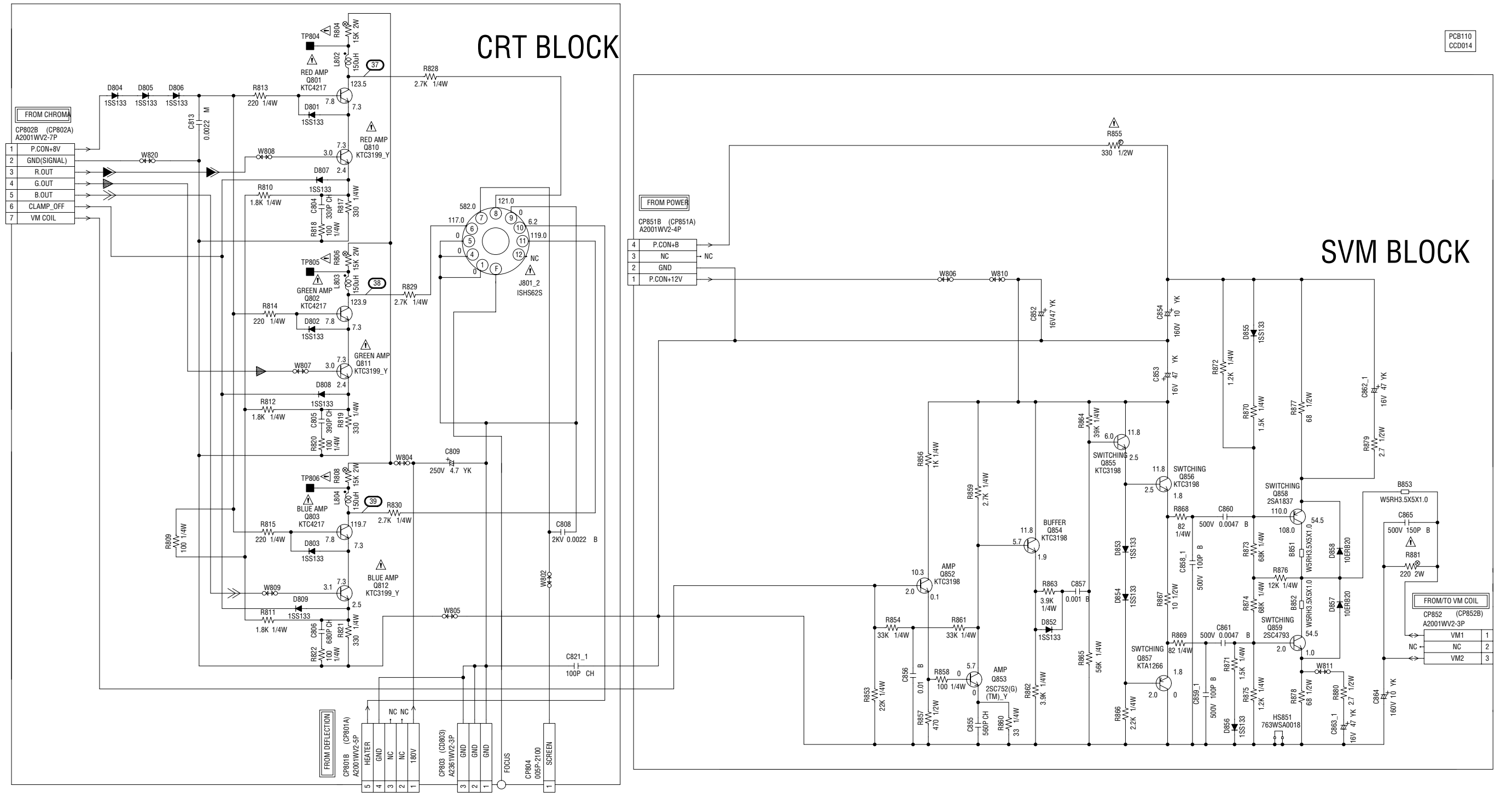

## (VM COIL PCB)

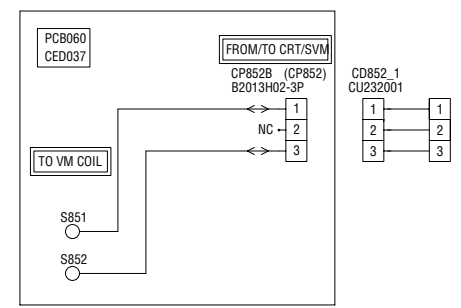

NOTE: THE DC VOLTAGE AT EACH PART WAS MEASURED WITH THE DIGITAL TESTER WHEN THE COLOR BROADCAST WAS RECEIVED IN GOOD CONDITION AND PICTURE IS NORMAL.

NOTE: THIS SCHEMATIC DIAGRAM IS THE LATEST AT THE TIME OF PRINTING AND SUBJECT TO CHANGE WITHOUT NOTICE.

**CAUTION** SINCE THESE PARTS MARKED BY ARE CRITICAL FOR SAFETY, USE ONES DESCRIBED IN PARTS LIST ONLY.

**ATTENTION** LES PIÈCES RÉPARÉES PAR UN ÉTANT DANGEREUSES AN POINT DE VUE SÉCURITÉ N'UTILISER QUE CELLES DÉCRITES DANS LA NOMENCLATURE DES PIÈCES.

R.SIGNAL  
 G.SIGNAL  
 B.SIGNAL

## MICON

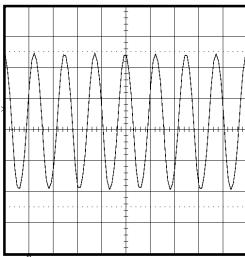

① 1V 0.1 $\mu$ s/div

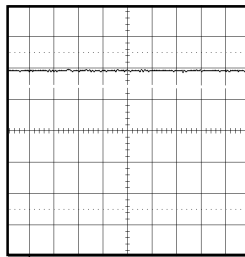

② 1V 1 $\mu$ s/div

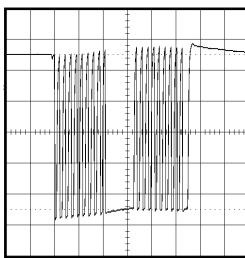

③ 1V 50 $\mu$ s/div

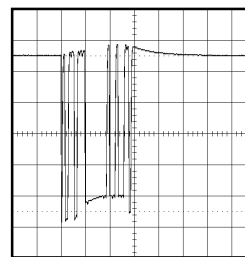

④ 1V 0.1ms/div

## CHROMA

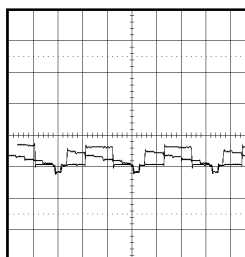

⑦ 1V 20 $\mu$ s/div

## WAVEFORMS

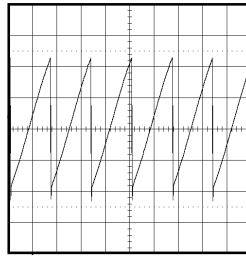

⑧ 0.5V 10ms/div

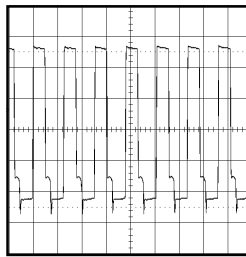

⑨ 1V 50 $\mu$ s/div

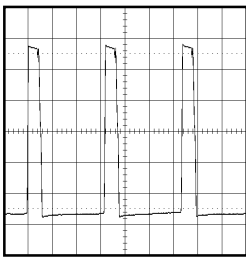

⑩ 2V 20 $\mu$ s/div

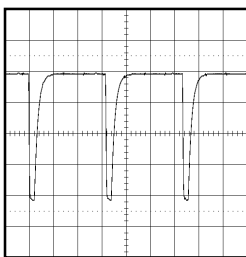

⑪ 0.5V 20 $\mu$ s/div

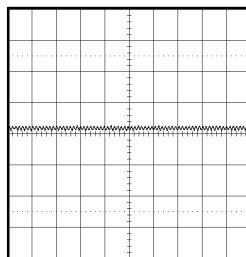

⑫ 1V 2 $\mu$ s/div

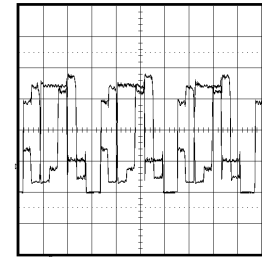

⑬ 1V 20 $\mu$ s/div

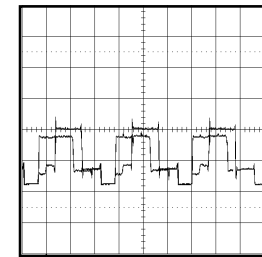

⑭ 2V 20 $\mu$ s/div

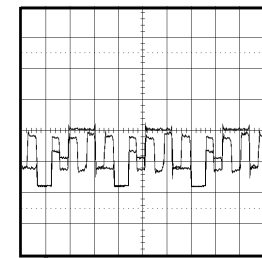

⑮ 2V 20 $\mu$ s/div

## DEFLECTION

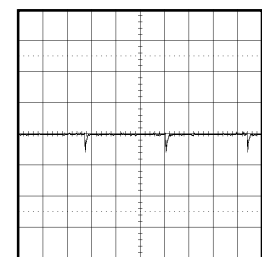

⑯ 2V 5ms/div

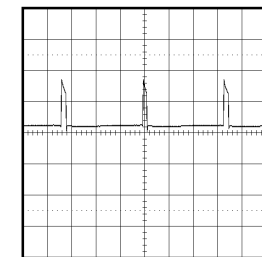

⑰ 20V 5ms/div

**NOTE:** The following waveforms were measured at the point of the corresponding balloon number in the schematic diagram.

## WAVEFORMS

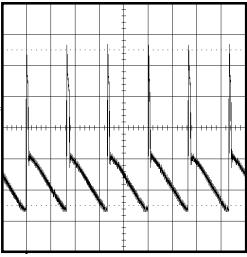

⑱ 10V 10ms/div

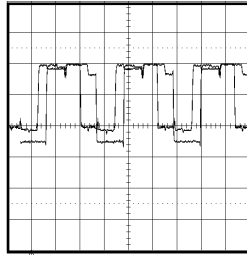

⑳ 50V 20 $\mu$ s/div

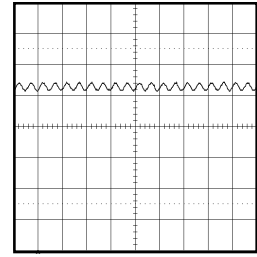

㉑ 2V 5ms/div

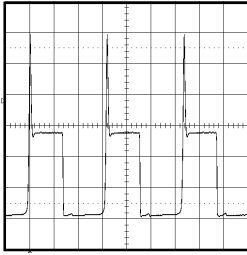

㉒ 20V 20 $\mu$ s/div

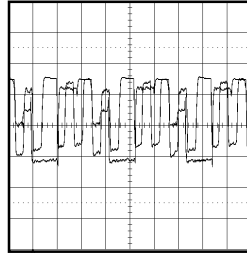

㉓ 50V 20 $\mu$ s/div

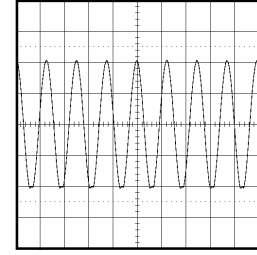

㉔ 5V 2ms/div

## SOUND

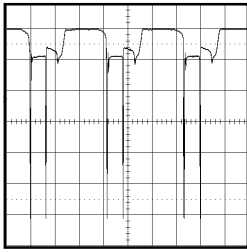

㉕ 2V 20 $\mu$ s/div

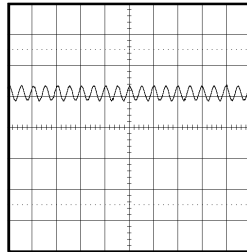

㉖ 2V 5ms/div

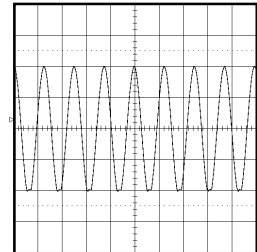

㉗ 5V 2ms/div

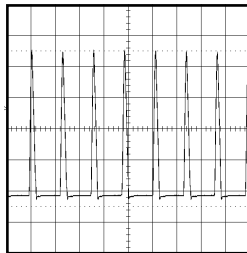

㉘ 200V 50 $\mu$ s/div

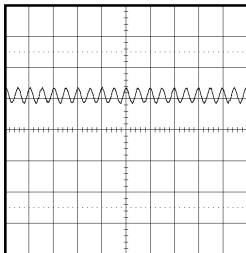

㉙ 2V 5ms/div

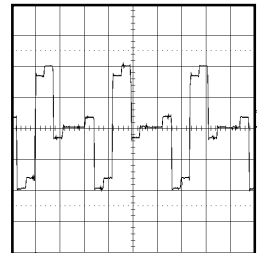

㉚ 200mV 20 $\mu$ s/div

## AV

### CRT/SVM

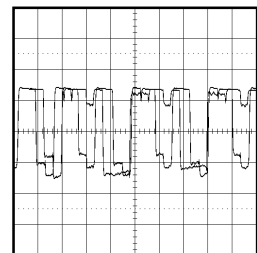

㉛ 50V 20 $\mu$ s/div

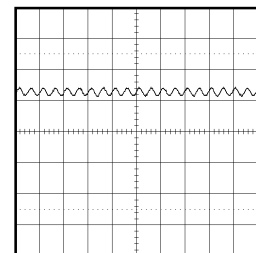

㉜ 2V 5ms/div

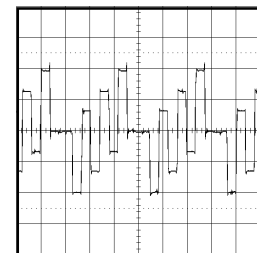

㉝ 200mV 20 $\mu$ s/div

**NOTE:** The following waveforms were measured at the point of the corresponding balloon number in the schematic diagram.



# MECHANICAL EXPLODED VIEW (PACKING DIAGRAM)

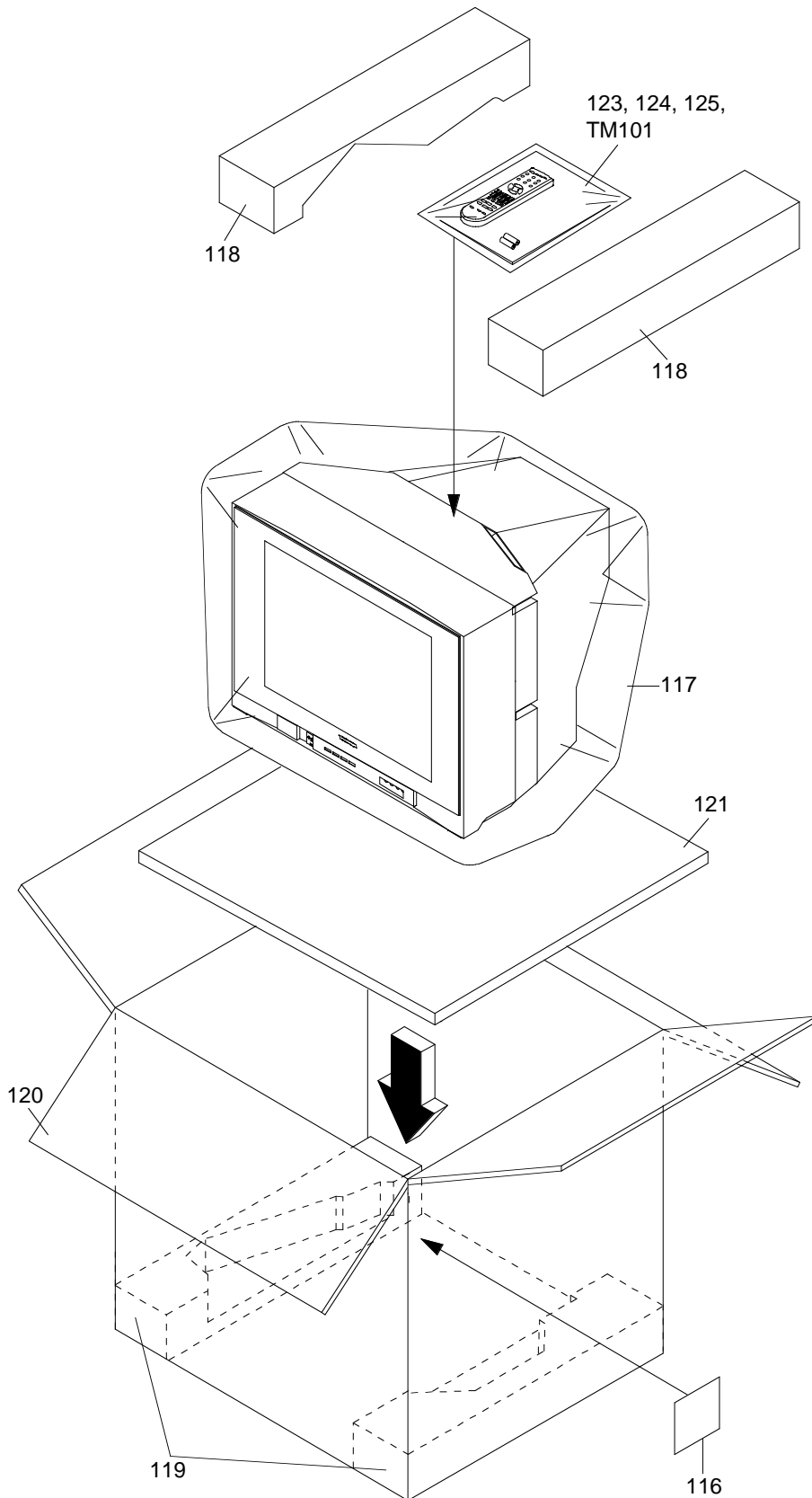

# MECHANICAL REPLACEMENT PARTS LIST

Location No.	TSB P/N	Reference No.	Description	
101	AE006007	7A701A311A	FRONT CABI ASS'Y	
101A	AE005744	701WPJC950	CABINET,FRONT	
101B	AD302143	711WPA0182	PLATE,FRONT	
101C	AE003066	712WPBA089	DOOR	
101D	AD302145	713WPA0261	GLASS,LED	
101E	AD302146	723549A012	AV LABEL	
101F	AD302008	7235490036	BADGE,BRAND	
101G	AD302147	735WPA0725	STOPPER,BUTTON	
101H	AD302010	735WPA0732	STOPPER,BUTTON2	
101I	AE003067	735WPBB014	BUTTON,FRAME	
101J	AE003068	735WPJA823	BUTTON,POWER	
101K	AE003069	800WQA070	FELT SHEET	
102	AE005745	7A702A092A	BACK CABI ASS'Y	
102A	AE006279	702WPAA812	CABINET,BACK	
102B	AE006226	800WQA090	FELT SHEET	
103	BZ710660	741WUA0021	SPRING,EARTH	
106	AE006280	722549A422	SHEET,RATING	
107	AE006281	723000C814	POP LABEL	
108	AE005650	723000C727	SHEET,CAUTION	
109	AE006282	726000A081	SHEET,CRT SERVICEMAN	
110	AD302015	761WPA0220	HOLDER,SPEAKER	
111	BZ710259	762WPA0011	HOLDER,CRT WIRE	
112	AE005971	769WSAA012	WASHER CRT T=0.5	
113	AD300518	801WR00001	DAMPER,SPEAKER	
114	AE000053	800WROA011	SHEET,CRT SUPPORT (D)	
115	BZ710260	899HV3T000	HOLDER,ANODE WIRE	
116	AE006283	723000C815	SHEET,BAR CODE	
117	AE006145	791WHAA116	FILM BAG	
118	AD302153	792WHA0438	PACKAGE, TOP	
119	AD302154	792WHA0439	PACKAGE,BOTTOM	
120	AE006284	793WCDC596	GIFT BOX	
121	AE006285	795WCDA017	PAD	740x569
122	AE006286	A3M6086975	INSTRUCTION BOOK KIT	
123	AE005582	JA4KD200	POLYBAG,INSTRUCTION(REDCAUTION)	
124	AE006287	J3M60821A	INSTRUCTION BOOK	
125	AE004983	J2D60117A	REGISTRATION CARD	
201	AE004847	8117540A6U	SCREW,TAP TITE(B0) TRUSS	4x16
202	AE006235	8117140A2U	SCREW,TAPPING(B0) PAN	4x12
203	AE005916	8141J50C5U	SCREW,TAP TITE(P) GW22	5x35
204	AE003528	8110630A0U	SCREW,TAP TITE(P) BRAZIER	3x10
205	AE003524	8109I30A0U	SCREW,TAP TITE(B) WH7	3x10
206	AE005917	810963080Q	SCREW,TAP TITE(B) BRAZIER	3x8
207	AE003531	810763080U	SCREW,TAP TITE(S) BRAZIER	3x8
208	AE005659	8109I3080U	SCREW,TAP TITE(B) WH7	3x8
209	AE005398	8162540A6U	SCREW,TAPPING (B0) WASHER 18	

# MECHANICAL REPLACEMENT PARTS LIST

Location No.	TSB P/N	Reference No.	Description	
101	AE006007	7A701A311A	FRONT CABI ASS'Y	
101A	AE005744	701WPJC950	CABINET,FRONT	
101B	AD302143	711WPA0182	PLATE,FRONT	
101C	AE003066	712WPBA089	DOOR	
101D	AD302145	713WPA0261	GLASS,LED	
101E	AD302146	723549A012	AV LABEL	
101F	AD302008	7235490036	BADGE,BRAND	
101G	AD302147	735WPA0725	STOPPER,BUTTON	
101H	AD302010	735WPA0732	STOPPER,BUTTON2	
101I	AE003067	735WPBB014	BUTTON,FRAME	
101J	AE003068	735WPJA823	BUTTON,POWER	
101K	AE003069	800WQA070	FELT SHEET	
102	AE005745	7A702A092A	BACK CABI ASS'Y	
102A	AE006279	702WPAA812	CABINET,BACK	
102B	AE006226	800WQA090	FELT SHEET	
103	BZ710660	741WUA0021	SPRING,EARTH	
104	AE006242	722000A266	SHEET,HWC	
105	AE006166	722000A267	SHEET,CSA WARNING	
106	AE006288	722549A447	SHEET,RATING	
107	AE006289	723000C866	POP LABEL	
108	AE006290	723000C728	SHEET,CAUTION	
109	AE006282	726000A081	SHEET,CRT SERVICEMAN	
110	AD302015	761WPA0220	HOLDER,SPEAKER	
111	BZ710259	762WPA0011	HOLDER,CRT WIRE	
112	AE005971	769WSAA012	WASHER CRT T=0.5	
113	AD300518	801WR00001	DAMPER,SPEAKER	
114	AE000053	800WROA011	SHEET,CRT SUPPORT (D)	
115	BZ710260	899HV3T000	HOLDER,ANODE WIRE	
116	AE006291	723000C867	SHEET,BAR CODE	
117	AE006145	791WHAA116	FILM BAG	
118	AD302153	792WHA0438	PACKAGE, TOP	
119	AD302154	792WHA0439	PACKAGE,BOTTOM	
120	AE006292	793WCDC674	GIFT BOX	
121	AE006285	795WCDA017	PAD	740x569
122	AE006293	A3M6096975	INSTRUCTION BOOK KIT	
123	AE006098	JA4KD100	POLYBAG,INSTRUCTION(RED CAUTION)	
124	AE006294	J3M60921A	INSTRUCTION BOOK	
201	AE004847	8117540A6U	SCREW,TAP TITE(B0) TRUSS	4x16
202	AE006235	8117140A2U	SCREW,TAPPING(B0) PAN	4x12
203	AE005916	8141J50C5U	SCREW,TAP TITE(P) GW22	5x35
204	AE003528	8110630A0U	SCREW,TAP TITE(P) BRAZIER	3x10
205	AE003524	8109I30A0U	SCREW,TAP TITE(B) WH7	3x10
206	AE005917	810963080Q	SCREW,TAP TITE(B) BRAZIER	3x8
207	AE003531	810763080U	SCREW,TAP TITE(S) BRAZIER	3x8
208	AE005659	8109I3080U	SCREW,TAP TITE(B) WH7	3x8
209	AE005398	8162540A6U	SCREW,TAPPING (B0) WASHER 18	

# ELECTRICAL REPLACEMENT PARTS LIST

Location No.	TSB P/N	Reference No.	Description
<b>RESISTORS</b>			
△ R402	AE006295	R65501680J	R,FUSE 68 OHM 1W
△ R410	BZ210087	R3X18A221J	R,METAL OXIDE 220 OHM 2W
△ R419	AE000415	R3X1811R5J	R,METAL OXIDE 1.5 OHM 1W
△ R426	BZ210030	R4X5T4472F	R,METAL 4.7K OHM 1/4W
△ R434	AD301972	R5X2CF5R6J	R,CEMENT 5.6 OHM 10W
△ R436	BZ210023	R4X5T4183F	R,METAL 18K OHM 1/4W
△ R438	BZ210111	R3X28B3R3J	R,METAL OXIDE 3.3 OHM 3W
△ R439	BZ210003	R3K181102J	R,METAL OXIDE 1K OHM 1W
△ R441	BZ210231	R4X5T6153F	R,METAL 15K OHM 1/6W
△ R452	AD301385	R3X18A391J	R,METAL OXIDE 390 OHM 2W
△ R459	AD301595	R65582010J	R,FUSE 1 OHM 1/2W
△ R500	BZ210080	R0G3K2275K	RC 2.7M OHM 1/2W
△ R501	AD301596	R5X2AE010J	R,CEMENT 1 OHM 7W
△ R502	BZ210249	R3X28A331J	R,METAL OXIDE 330 OHM 2W
△ R506	BZ210162	R002T4682J	RC 6.8K OHM 1/4W
△ R517	BZ210191	R3X28B010J	R,METAL OXIDE 1 OHM 3W
△ R520	BZ210206	R002T2155J	RC 1.5M OHM 1/2W
△ R527	BZ210149	R3X18AR68J	R,METAL OXIDE 0.68 OHM 2W
△ R541	AE005735	R63881R22J	R,FUSE 0.22 OHM 1W
△ R542	BZ210248	R3X181R15J	R,METAL OXIDE 0.15 OHM 1W
R601	AE006340	R3X181150J	R,METAL OXIDE 15 OHM 1W
△ R602	AD301975	R3X28B120J	R,METAL OXIDE 12 OHM 3W
△ R649	AD301975	R3X28B120J	R,METAL OXIDE 12 OHM 3W
△ R804	BZ210026	R3X18A153J	R,METAL OXIDE 15K OHM 2W
△ R806	BZ210026	R3X18A153J	R,METAL OXIDE 15K OHM 2W
△ R808	BZ210026	R3X18A153J	R,METAL OXIDE 15K OHM 2W
△ R855	AD301019	R65582331J	R,FUSE 330 OHM 1/2W
△ R881	BZ210087	R3X18A221J	R,METAL OXIDE 220 OHM 2W
R1014	AE006741	R00204821J	RC 820 OHM 1/4W
<b>CAPACITORS</b>			
C156	AE004040	P6M900105J	CMPL 1 UF 50V TF
△ C402	AE000416	P232W1103J	CMP 0.01 UF 100V MMTS
△ C408	BZ110032	E5EZF3102M	CE 1000 UF 25V
△ C412	AD301303	P4N8FJ332H	CMPP 0.0033UF 1.25KV
△ C413	AD301977	E0ELF4102M	CE 1000 UF 35V
C418	BZ210173	P4J7F3474J	CMPP 0.47 UF 250V PMS
△ C420	AD300723	P4N8FJ153H	CMPP C 0.015 UF 1.25KV
△ C421	AD301600	P3N1F5223J	CPP 0.022 UF 630V
C425	BZ110202	C0PLRR713K	CC 0.001 UF 2KV R
△ C426	BZ110225	E5EZF220M	CE 22 UF 250V
△ C430	BZ110195	E02LU8220M	CE 22 UF 100V
C442	AE006084	E736F56R8M	CE 6.8 UF 50V
△ C501	AD300067	E02LF4102M	CE 1000 UF 35V
△ C502	BZ110202	C0PLRR713K	CC 0.001 UF 2KV R
△ C503	BZ110202	C0PLRR713K	CC 0.001 UF 2KV R
△ C504	AD301729	E02LU52R2M	CE 2.2 UF 50V
△ C505	BZ110025	P2122B224M	CMP 0.22 UF 275V ECQUL
△ C506	BZ110035	P2122B104M	CMP 0.1 UF 275V ECQUL
△ C507	AE000417	E51DFC821M	CE 820 UF 200V
△ C508	BZ110222	CD39E0MH3M	CC 0.0022UF 250V
△ C513	AD301026	CD39E0M13M	CC 0.001 UF 250V
C514	AD300067	E02LF4102M	CE 1000 UF 35V
C517	AE000874	C0PLRR7E3K	CC 0.0015 UF 2KV R
△ C519	AD301026	CD39E0M13M	CC 0.001 UF 250V
△ C521	AE006083	E61DFB221M	CE 220 UF 160V
△ C527	BZ110119	E02LF2222M	CE 2200 UF 16V
△ C535	BZ110201	C0PLRR7H3K	CC 0.0022 UF 2KV R
C808	BZ110226	C0JBB07H3K	CC 0.0022UF 2KV B
△ C855	AE000418	CQGTCH4S2J	CC 560 PF 50V CH
C1003	BZ210176	E02LF3222M	CE 2200 UF 25V
C1004	BZ110053	E02LF3102M	CE 1000 UF 25V
C1009	BZ110053	E02LF3102M	CE 1000 UF 25V
<b>DIODES</b>			
D001	BZ410037	D97U03301B	DIODE,ZENER MTZJ33B T-77
D104	BZ410006	D1VT001330	DIODE,SILICON 1SS133T-77
D105	BZ410006	D1VT001330	DIODE,SILICON 1SS133T-77
D106	BZ410020	D97U05R11B	DIODE,ZENER MTZJ5.1B T-77
D107	BZ410006	D1VT001330	DIODE,SILICON 1SS133T-77
D108	BZ410006	D1VT001330	DIODE,SILICON 1SS133T-77
D109	BZ410054	0021721150	LED SLR-342VCT32
D110	BZ410006	D1VT001330	DIODE,SILICON 1SS133T-77

# ELECTRICAL REPLACEMENT PARTS LIST

Location No.	TSB P/N	Reference No.	Description
<b>DIODES</b>			
D113	BZ410021	D97U05R61B	DIODE,ZENER MTZJ5.6B T-77
D402	BZ410043	D2WT011E10	DIODE,SILICON 11E1-EIC
D403	BZ410019	D97U03001B	DIODE,ZENER MTZJ30B T-77
D404	BZ410020	D97U05R11B	DIODE,ZENER MTZJ5.1B T-77
△D405	BZ410063	D2WTAU02A0	DIODE,SILICON AU02A-EIC
△D406	BZ410021	D97U05R61B	DIODE,ZENER MTZJ5.6B T-77
△D407	BZ410063	D2WTAU02A0	DIODE,SILICON AU02A-EIC
D408	AD302110	D2CF0715L0	DIODE,SILICON ERD07-15L50
D409	AD301980	D2CF2016L0	DIODE,SILICON FE201-6L49
D410	BZ410019	D97U03001B	DIODE,ZENER MTZJ30B T-77
△D411	BZ410063	D2WTAU02A0	DIODE,SILICON AU02A-EIC
D414	BZ410043	D2WT011E10	DIODE,SILICON 11E1-EIC
D415	BZ410043	D2WT011E10	DIODE,SILICON 11E1-EIC
D416	BZ410006	D1VT001330	DIODE,SILICON 1SS133T-77
D417	BZ410006	D1VT001330	DIODE,SILICON 1SS133T-77
D419	BZ410006	D1VT001330	DIODE,SILICON 1SS133T-77
△D501	BZ410062	D2WTRM11C0	DIODE,SILICON RM11C-EIC
△D502	BZ410062	D2WTRM11C0	DIODE,SILICON RM11C-EIC
△D503	BZ410062	D2WTRM11C0	DIODE,SILICON RM11C-EIC
△D504	BZ410062	D2WTRM11C0	DIODE,SILICON RM11C-EIC
△D505	AE006082	D28F0PRA60	DIODE,RECTIFIER 30PRA60-FC
△D506	AD300731	D2WXN49370	DIODE,SILICON 1N4937
D507	BZ410006	D1VT001330	DIODE,SILICON 1SS133T-77
D508	BZ410064	D97U03R91B	DIODE,ZENER MTZJ3.9B T-77
D509	AD300671	D97U01801B	DIODE,ZENER MTZJ18B T-77
△D510	AD301980	D2CF2016L0	DIODE,SILICON FE201-6L49
△D511	AD300731	D2WXN49370	DIODE,SILICON 1N4937
△D512	BZ410010	D28T21DQN9	DIODE,SCHOTTKY 21DQ09N-TA2B1
D513	BZ410006	D1VT001330	DIODE,SILICON 1SS133T-77
D514	BZ410006	D1VT001330	DIODE,SILICON 1SS133T-77
D516	BZ410006	D1VT001330	DIODE,SILICON 1SS133T-77
D517	BZ410006	D1VT001330	DIODE,SILICON 1SS133T-77
D520	BZ410006	D1VT001330	DIODE,SILICON 1SS133T-77
△D523	AD300671	D97U01801B	DIODE,ZENER MTZJ18B T-77
D524	BZ410006	D1VT001330	DIODE,SILICON 1SS133T-77
D525	AD300671	D97U01801B	DIODE,ZENER MTZJ18B T-77
D528	BZ410021	D97U05R61B	DIODE,ZENER MTZJ5.6B T-77
D601	BZ410006	D1VT001330	DIODE,SILICON 1SS133T-77
D602	BZ410058	D97U08R21B	DIODE,ZENER MTZJ8.2B T-77
D604	AD300070	D97U01201B	DIODE,ZENER MTZJ12B T-77
D605	BZ410006	D1VT001330	DIODE,SILICON 1SS133T-77
D606	BZ410006	D1VT001330	DIODE,SILICON 1SS133T-77
D607	BZ410006	D1VT001330	DIODE,SILICON 1SS133T-77
D608	BZ410043	D2WT011E10	DIODE,SILICON 11E1-EIC
D701	AD300070	D97U01201B	DIODE,ZENER MTZJ12B T-77
D702	AD300070	D97U01201B	DIODE,ZENER MTZJ12B T-77
D703	AD300070	D97U01201B	DIODE,ZENER MTZJ12B T-77
D704	AD300070	D97U01201B	DIODE,ZENER MTZJ12B T-77
D705	AD300070	D97U01201B	DIODE,ZENER MTZJ12B T-77
D706	AD300070	D97U01201B	DIODE,ZENER MTZJ12B T-77
D709	BZ410066	D97U06R21B	DIODE,ZENER MTZJ6.2B T-77
D801	BZ410006	D1VT001330	DIODE,SILICON 1SS133T-77
D802	BZ410006	D1VT001330	DIODE,SILICON 1SS133T-77
D803	BZ410006	D1VT001330	DIODE,SILICON 1SS133T-77
D804	BZ410006	D1VT001330	DIODE,SILICON 1SS133T-77
D805	BZ410006	D1VT001330	DIODE,SILICON 1SS133T-77
D806	BZ410006	D1VT001330	DIODE,SILICON 1SS133T-77
D807	BZ410006	D1VT001330	DIODE,SILICON 1SS133T-77
D808	BZ410006	D1VT001330	DIODE,SILICON 1SS133T-77
D809	BZ410006	D1VT001330	DIODE,SILICON 1SS133T-77
D852	BZ410006	D1VT001330	DIODE,SILICON 1SS133T-77
D853	BZ410006	D1VT001330	DIODE,SILICON 1SS133T-77
D854	BZ410006	D1VT001330	DIODE,SILICON 1SS133T-77
D855	BZ410006	D1VT001330	DIODE,SILICON 1SS133T-77
D856	BZ410006	D1VT001330	DIODE,SILICON 1SS133T-77
D857	AE006060	D28T0ERB20	DIODE,RECTIFIER 10ERB20-TA1B2
D858	AE006060	D28T0ERB20	DIODE,RECTIFIER 10ERB20-TA1B2
<b>ICS</b>			
IC101	AE006067	I56F07090B	IC OEC7090B
IC199	AE006296	A3M6086015	INIT DATA BR24L16FJ-WE2
IC301	AE006297	I0QJ021500	IC NJM2150AM(TE1)

# ELECTRICAL REPLACEMENT PARTS LIST

Location No.	TSB P/N	Reference No.	Description
			<b>ICS</b>
IC302	AD301983	I01FF58910	AN5891SA-E1V
△IC401	BZ611117	I03TD80410	LA78041
△IC504	BZ410088	0002E00610	PHOTO COUPLER
IC601	AE002803	I06FC1283A	IC
IC701	AD301988	I0UF015010	IC
IC702	AD301988	I0UF015010	IC
IC902	BZ611068	I01FF58290	IC
△IC1001	AE003081	I0FSP7808B	IC
IC1501	AE003002	I03FE76605	IC
IC1502	AD301988	I0UF015010	IC
IC1503	AD301988	I0UF015010	IC
			<b>TRANSISTORS</b>
Q101	BZ510109	TCAA3875SY	TRANSISTOR,SILICON
Q103	BZ510109	TCAA3875SY	TRANSISTOR,SILICON
△Q402	BZ510097	TCAT03227Y	TRANSISTOR,SILICON
△Q405	AD302136	TD50026380	TRANSISTOR,SILICON
Q408	BZ510073	TAATA12660	TRANSISTOR,SILICON
Q409	BZ510073	TAATA12660	TRANSISTOR,SILICON
Q410	BZ510110	TC30041590	TRANSISTOR,SILICON
Q411	BZ510109	TCAA3875SY	TRANSISTOR,SILICON
△Q502	BZ510098	T220033260	FET
△Q503	BZ510005	TA3T1371A0	TRANSISTOR,SILICON
Q504	BZ510069	TCATC31980	TRANSISTOR,SILICON
△Q505	BZ510011	TC3T029090	TRANSISTOR,SILICON
△Q507	BZ510069	TCATC31980	TRANSISTOR,SILICON
△Q508	BZ510077	TAAT012714	TRANSISTOR,SILICON
Q509	BZ510069	TCATC31980	TRANSISTOR,SILICON
△Q512	BZ510004	TA3T016240	TRANSISTOR,SILICON
△Q514	BZ510070	TCAT032034	TRANSISTOR,SILICON
Q601	BZ510105	TCAT03209Y	TRANSISTOR,SILICON
Q602	BZ510105	TCAT03209Y	TRANSISTOR,SILICON
Q603	BZ510109	TCAA3875SY	TRANSISTOR,SILICON
Q604	BZ510105	TCAT03209Y	TRANSISTOR,SILICON
Q605	BZ510109	TCAA3875SY	TRANSISTOR,SILICON
Q606	BZ510105	TCAT03209Y	TRANSISTOR,SILICON
Q607	BZ510070	TCAT032034	TRANSISTOR,SILICON
Q610	BZ510109	TCAA3875SY	TRANSISTOR,SILICON
Q611	BZ510105	TCAT03209Y	TRANSISTOR,SILICON
Q613	BZ510109	TCAA3875SY	TRANSISTOR,SILICON
Q614	BZ510108	TAAA1504SY	TRANSISTOR,SILICON
Q709	BZ510108	TAAA1504SY	TRANSISTOR,SILICON
Q711	BZ510109	TCAA3875SY	TRANSISTOR,SILICON
Q712	BZ510109	TCAA3875SY	TRANSISTOR,SILICON
△Q801	BZ510091	TCA0042170	TRANSISTOR,SILICON
△Q802	BZ510091	TCA0042170	TRANSISTOR,SILICON
△Q803	BZ510091	TCA0042170	TRANSISTOR,SILICON
△Q810	BZ510100	TCATC3199Y	TRANSISTOR,SILICON
△Q811	BZ510100	TCATC3199Y	TRANSISTOR,SILICON
△Q812	BZ510100	TCATC3199Y	TRANSISTOR,SILICON
Q852	BZ510069	TCATC31980	TRANSISTOR,SILICON
Q853	AD300024	TCUT00752Y	TRANSISTOR,SILICON
Q854	BZ510069	TCATC31980	TRANSISTOR,SILICON
Q855	BZ510069	TCATC31980	TRANSISTOR,SILICON
Q856	BZ510069	TCATC31980	TRANSISTOR,SILICON
Q857	BZ510073	TAATA12660	TRANSISTOR,SILICON
Q858	AD300029	TAU0018370	TRANSISTOR,SILICON
Q859	AD300025	TCU0047930	TRANSISTOR,SILICON
Q901	BZ510108	TAAA1504SY	TRANSISTOR,SILICON
Q902	BZ510108	TAAA1504SY	TRANSISTOR,SILICON
Q1001	BZ510068	TNAAJ05003	COMPOUND TRANSISTOR
Q1503	BZ510109	TCAA3875SY	TRANSISTOR,SILICON
Q1504	BZ510109	TCAA3875SY	TRANSISTOR,SILICON
Q1507	BZ510109	TCAA3875SY	TRANSISTOR,SILICON
Q1508	BZ510109	TCAA3875SY	TRANSISTOR,SILICON
			<b>COILS &amp; TRANSFORMERS</b>
L301	BZ310041	02167F101J	COIL
L401	AD301644	021L75472J	COIL
L402	BZ310187	022100034A	COIL,LINEARITY
L403	AD301606	02DK000058	COIL,CHOKE
△L501	AD301124	029T000101	COIL,LINE FILTER
△L503	BZ310188	028R250009	COIL,DEGAUSS

# ELECTRICAL REPLACEMENT PARTS LIST

Location No.	TSB P/N	Reference No.	Description
<b>COILS &amp; TRANSFORMERS</b>			
L601	AD301990	021LA6330J	COIL 33 UH
L802	BZ310170	021673151K	COIL 150 UH
L803	BZ310170	021673151K	COIL 150 UH
L804	BZ310170	021673151K	COIL 150 UH
L901	BZ310041	02167F101J	COIL 100 UH
L1501	BZ310041	02167F101J	COIL 100 UH
L1502	AD301417	02167F221J	COIL 220 UH
L1503	AD301417	02167F221J	COIL 220 UH
L1505	AD300613	02167F150J	COIL 15 UH
L1508	BZ310041	02167F101J	COIL 100 UH
L1510	AD300613	02167F150J	COIL 15 UH
L1511	AD300613	02167F150J	COIL 15 UH
L1512	BZ310183	021LA6220J	COIL 22 UH
T401	BZ310189	0450190161	TRANS,HORIZONTAL DRIVE ETH19Y203AY
△T501	AD301034	048140066S	TRANSFORMER,SWITCHING 8140066S
<b>JACKS</b>			
J701	AE002759	060J431020	RCA JACK MSP-213V2-432_NI_LF
J702	AE006074	063Q700011	JACK YKF51-5503N
J703	AE002759	060J431020	RCA JACK MSP-213V2-432_NI_LF
J704	AE002761	060J411032	RCA JACK MSP-213V1-652_NI_LF
J705	AE004756	060J401104	RCA JACK MTJ-032-03A-30FE
J706	AE004758	060J401106	RCA JACK MTJ-032-03A-32FE
J707	AE004757	060J401105	RCA JACK MTJ-032-03A-31FE
J708	AE002759	060J431020	RCA JACK MSP-213V2-432_NI_LF
△J801	AD301936	066F130021	SOCKET,CATHODE RAY,TUBE ISHS62S
△J1001	AE003431	060J131016	HEADPHONE JACK MSJ-2000_AG
<b>SWITCHES</b>			
SW101	BZ612010	0504101T34	SWITCH,TACT EVQ21505R
SW102	BZ612010	0504101T34	SWITCH,TACT EVQ21505R
SW103	BZ612010	0504101T34	SWITCH,TACT EVQ21505R
SW104	BZ612010	0504101T34	SWITCH,TACT EVQ21505R
SW105	BZ612010	0504101T34	SWITCH,TACT EVQ21505R
<b>VARIABLE RESISTORS</b>			
VR401	BZ210218	V1K63H3BTE	VOLUME,SEMI FIXED NVG6TLTAB222
VR502	BZ210101	V1163H4BTC	VOLUME,SEMI FIXED EVNCYAA03BE4
<b>P.C. BOARD ASSEMBLIES</b>			
PCB010	AE006298	A3M6086010	PCB ASS'Y CMD016A
PCB060	AE006299	A3M6086060	PCB ASS'Y CED037A
PCB110	AE006300	A3M6086110	PCB ASS'Y CCD014A
<b>MISCELLANEOUS</b>			
B401	BZ310129	024HT03564	CORE,BEADS W4BRH3.5X6X1.0
B402	BZ310129	024HT03564	CORE,BEADS W4BRH3.5X6X1.0
B405	BZ310129	024HT03564	CORE,BEADS W4BRH3.5X6X1.0
B501	BZ310045	024AT03481	CORE,BEADS BL02RN1-R62T2
B504	BZ310121	024HT03553	CORE,BEADS W5RH3.5X5X1.0
B851	BZ310121	024HT03553	CORE,BEADS W5RH3.5X5X1.0
B852	BZ310121	024HT03553	CORE,BEADS W5RH3.5X5X1.0
B853	BZ310121	024HT03553	CORE,BEADS W5RH3.5X5X1.0
BT001	AE005640	141R004016	BATTERY,MANGAN GR03X-SP2
BT002	AE005640	141R004016	BATTERY,MANGAN GR03X-SP2
△CD501	AE006077	1209615904	CORD,AC BUSH 9615904
CD801	BZ614484	06CU253401	CORD,CONNECTOR CU253401
CD802	AE000423	06CU274501	CORD,CONNECTOR CU274501
CD803	AE005222	06C383037A	CORD,CONNECTOR C383037A
CD851	AD302371	06CU244701	CORD,CONNECTOR CU244701
CD852	AD301043	06CU232001	CORD,CONNECTOR CU232001
CP101	BZ614102	0694270139	CONNECTOR PCB SIDE 173979-7
△CP401	AE006075	069X460109	CONNECTOR PCB SIDE B06B-DVS-L (LF)
△CP501	BZ614176	069S320419	CONNECTOR PCB SIDE A3963WV2-3PD
△CP502	BZ614283	069S420110	CONNECTOR PCB SIDE A1561WV2-2P
CP507	BZ614444	069D01001A	CONNECTOR PCB SIDE 003P-2100
CP508	BZ614444	069D01001A	CONNECTOR PCB SIDE 003P-2100
CP803	AD301996	069S330010	CONNECTOR PCB SIDE A2361WV2-3P
CP804	BZ614058	069W010010	CONNECTOR PCB SIDE 005P-2100
CP852	BZ614350	069S230629	CONNECTOR PCB SIDE A2001WV2-3P
CD1001	AE006213	06C3146903	CORD,CONNECTOR C3146903
CP1001	AD301045	069S140419	CONNECTOR PCB SIDE A2502WV2-4P
CP801A	BZ614276	067U005049	WIRE HOLDER B2013H02-5P
CP801B	AD300752	069S250629	CONNECTOR PCB SIDE A2001WV2-5P
CP802A	AD301997	067U007029	WIRE HOLDER B2013H02-7P
CP802B	BZ614485	069S270629	CONNECTOR PCB SIDE A2001WV2-7P

# ELECTRICAL REPLACEMENT PARTS LIST

Location No.	TSB P/N	Reference No.	Description
<b>MISCELLANEOUS</b>			
CP851A	BZ614334	067U004029	WIRE HOLDER B2013H02-4P
CP851B	AD301998	069S240629	CONNECTOR PCB SIDE A2001WV2-4P
CP852B	BZ614349	067U003029	WIRE HOLDER B2013H02-3P
EL001	BZ614044	124120301A	EYE LET XRY20X30BD
EL002	BZ614043	124116281A	EYE LET XRY16X28BD
△F501	BZ614422	081PC6R305	FUSE 51MS063L
△FB401	AE003085	043224007F	TRANSFORMER,FLYBACK FSU24A001_M
FH501	AE002634	06710T0009	HOLDER,FUSE EYF-52BCY
FH502	AE002634	06710T0009	HOLDER,FUSE EYF-52BCY
OS101	AD301048	0773071001	REMOTE RECEIVER RPM7138-WH5
△RY501	AE006070	0560X20118	RELAY G5PA-1-SA(WEC)
△SP1001	AD301050	070C457003	SPEAKER SG05K07BRA
△SP1002	AD301050	070C457003	SPEAKER SG05K07BRA
△TH501	BZ410079	DF5EL3R0A0	DEGAUSS ELEMENT ZPB45BL3R0A
TM101	AE003009	076R0GV020	TRANSMITTER R25-1943
△TU001	AE006069	0163300018	RF UNIT 115-V-KA35ARB
△V801	AE003574	098W250402	CRT W/DY A60LVY196X11(OL)
X101	AD302002	100CT8R005	CRYSTAL HC-49/U-S
X602	BZ613004	100CT3R505	CRYSTAL HC-49/U

**RESISTOR**

RC..... CARBON RESISTOR

**CAPACITORS**

CC..... CERAMIC CAPACITOR  
 CE..... ALUMI ELECTROLYTIC CAPACITOR  
 CP..... POLYESTER CAPACITOR  
 CPP..... POLYPROPYLENE CAPACITOR  
 CPL..... PLASTIC CAPACITOR  
 CMP..... METAL POLYESTER CAPACITOR  
 CMPL..... METAL PLASTIC CAPACITOR  
 CMPP..... METAL POLYPROPYLENE CAPACITOR

# ELECTRICAL REPLACEMENT PARTS LIST

Location No.	TSB P/N	Reference No.	Description
<b>RESISTORS</b>			
△R402	AE006295	R65501680J	R,FUSE 68 OHM 1W
△R410	BZ210087	R3X18A221J	R,METAL OXIDE 220 OHM 2W
△R419	AE000415	R3X1811R5J	R,METAL OXIDE 1.5 OHM 1W
△R426	BZ210030	R4X5T4472F	R,METAL 4.7K OHM 1/4W
△R434	AD301972	R5X2CF5R6J	R,CEMENT 5.6 OHM 10W
△R436	BZ210023	R4X5T4183F	R,METAL 18K OHM 1/4W
△R438	BZ210111	R3X28B3R3J	R,METAL OXIDE 3.3 OHM 3W
△R439	BZ210003	R3K181102J	R,METAL OXIDE 1K OHM 1W
△R441	BZ210231	R4X5T6153F	R,METAL 15K OHM 1/6W
△R452	AD301385	R3X18A391J	R,METAL OXIDE 390 OHM 2W
△R459	AD301595	R65582010J	R,FUSE 1 OHM 1/2W
△R500	BZ210080	R0G3K2275K	RC 2.7M OHM 1/2W
△R501	AD301596	R5X2AE010J	R,CEMENT 1 OHM 7W
△R502	BZ210249	R3X28A331J	R,METAL OXIDE 330 OHM 2W
△R506	BZ210162	R002T4682J	RC 6.8K OHM 1/4W
△R517	BZ210191	R3X28B010J	R,METAL OXIDE 1 OHM 3W
△R520	BZ210206	R002T2155J	RC 1.5M OHM 1/2W
△R527	BZ210149	R3X18AR68J	R,METAL OXIDE 0.68 OHM 2W
△R541	AE005735	R63881R22J	R,FUSE 0.22 OHM 1W
△R542	BZ210248	R3X181R15J	R,METAL OXIDE 0.15 OHM 1W
R601	AE006340	R3X181150J	R,METAL OXIDE 15 OHM 1W
△R602	AD301975	R3X28B120J	R,METAL OXIDE 12 OHM 3W
△R649	AD301975	R3X28B120J	R,METAL OXIDE 12 OHM 3W
△R804	BZ210026	R3X18A153J	R,METAL OXIDE 15K OHM 2W
△R806	BZ210026	R3X18A153J	R,METAL OXIDE 15K OHM 2W
△R808	BZ210026	R3X18A153J	R,METAL OXIDE 15K OHM 2W
△R855	AD301019	R65582331J	R,FUSE 330 OHM 1/2W
△R881	BZ210087	R3X18A221J	R,METAL OXIDE 220 OHM 2W
R1014	AE006741	R00204821J	RC 820 OHM 1/4W
<b>CAPACITORS</b>			
C156	AE004040	P6M900105J	CMPL 1 UF 50V TF
△C402	AE000416	P232W1103J	CMP 0.01 UF 100V MMTS
△C408	BZ110032	E5EZF3102M	CE 1000 UF 25V
△C412	AD301303	P4N8FJ332H	CMPP 0.0033UF 1.25KV
△C413	AD301977	E0ELF4102M	CE 1000 UF 35V
C418	BZ210173	P4J7F3474J	CMPP 0.47 UF 250V PMS
△C420	AD300723	P4N8FJ153H	CMPP 0.015 UF 1.25KV
△C421	AD301600	P3N1F5223J	CPP 0.022 UF 630V
C425	BZ110202	C0PLRR713K	CC 0.001 UF 2KV R
△C426	BZ110225	E5EZF220M	CE 22 UF 250V
△C430	BZ110195	E02LU8220M	CE 22 UF 100V
C442	AE006084	E736F56R8M	CE 6.8 UF 50V
△C501	AD300067	E02LF4102M	CE 1000 UF 35V
△C502	BZ110202	C0PLRR713K	CC 0.001 UF 2KV R
△C503	BZ110202	C0PLRR713K	CC 0.001 UF 2KV R
△C504	AD301729	E02LU52R2M	CE 2.2 UF 50V
△C505	BZ110025	P2122B224M	CMP 0.22 UF 275V ECQUL
△C506	BZ110035	P2122B104M	CMP 0.1 UF 275V ECQUL
△C507	AE000417	E51DFC821M	CE 820 UF 200V
△C508	BZ110222	CD39E0MH3M	CC 0.0022UF 250V
△C513	AD301026	CD39E0M13M	CC 0.001 UF 250V
C514	AD300067	E02LF4102M	CE 1000 UF 35V
C517	AE000874	C0PLRR7E3K	CC 0.0015 UF 2KV R
△C519	AD301026	CD39E0M13M	CC 0.001 UF 250V
△C521	AE006083	E61DFB221M	CE 220 UF 160V
△C527	BZ110119	E02LF2222M	CE 2200 UF 16V
△C535	BZ110201	C0PLRR7H3K	CC 0.0022 UF 2KV R
C808	BZ110226	C0JBB07H3K	CC 0.0022UF 2KV B
△C855	AE000418	CQGTCH4S2J	CC 560 PF 50V CH
C1003	BZ210176	E02LF3222M	CE 2200 UF 25V
C1004	BZ110053	E02LF3102M	CE 1000 UF 25V
C1009	BZ110053	E02LF3102M	CE 1000 UF 25V
<b>DIODES</b>			
D001	BZ410037	D97U03301B	DIODE,ZENER MTZJ33B T-77
D104	BZ410006	D1VT001330	DIODE,SILICON 1SS133T-77
D105	BZ410006	D1VT001330	DIODE,SILICON 1SS133T-77
D106	BZ410020	D97U05R11B	DIODE,ZENER MTZJ5.1B T-77
D107	BZ410006	D1VT001330	DIODE,SILICON 1SS133T-77
D108	BZ410006	D1VT001330	DIODE,SILICON 1SS133T-77
D109	BZ410054	0021721150	LED SLR-342VCT32
D110	BZ410006	D1VT001330	DIODE,SILICON 1SS133T-77

# ELECTRICAL REPLACEMENT PARTS LIST

Location No.	TSB P/N	Reference No.	Description
<b>DIODES</b>			
D113	BZ410021	D97U05R61B	DIODE,ZENER
D402	BZ410043	D2WT011E10	DIODE,SILICON
D403	BZ410019	D97U03001B	DIODE,ZENER
D404	BZ410020	D97U05R11B	DIODE,ZENER
△D405	BZ410063	D2WTAU02A0	DIODE,SILICON
△D406	BZ410021	D97U05R61B	DIODE,ZENER
△D407	BZ410063	D2WTAU02A0	DIODE,SILICON
D408	AD302110	D2CF0715L0	DIODE,SILICON
D409	AD301980	D2CF2016L0	DIODE,SILICON
D410	BZ410019	D97U03001B	DIODE,ZENER
△D411	BZ410063	D2WTAU02A0	DIODE,SILICON
D414	BZ410043	D2WT011E10	DIODE,SILICON
D415	BZ410043	D2WT011E10	DIODE,SILICON
D416	BZ410006	D1VT001330	DIODE,SILICON
D417	BZ410006	D1VT001330	DIODE,SILICON
D419	BZ410006	D1VT001330	DIODE,SILICON
△D501	BZ410062	D2WTRM11C0	DIODE,SILICON
△D502	BZ410062	D2WTRM11C0	DIODE,SILICON
△D503	BZ410062	D2WTRM11C0	DIODE,SILICON
△D504	BZ410062	D2WTRM11C0	DIODE,SILICON
△D505	AE006082	D28F0PRA60	DIODE,RECTIFIER
△D506	AD300731	D2WXN49370	DIODE,SILICON
D507	BZ410006	D1VT001330	DIODE,SILICON
D508	BZ410064	D97U03R91B	DIODE,ZENER
D509	AD300671	D97U01801B	DIODE,ZENER
△D510	AD301980	D2CF2016L0	DIODE,SILICON
△D511	AD300731	D2WXN49370	DIODE,SILICON
△D512	BZ410010	D28T21DQN9	DIODE,SCHOTTKY
D513	BZ410006	D1VT001330	DIODE,SILICON
D514	BZ410006	D1VT001330	DIODE,SILICON
D516	BZ410006	D1VT001330	DIODE,SILICON
D517	BZ410006	D1VT001330	DIODE,SILICON
D520	BZ410006	D1VT001330	DIODE,SILICON
△D523	AD300671	D97U01801B	DIODE,ZENER
D524	BZ410006	D1VT001330	DIODE,SILICON
D525	AD300671	D97U01801B	DIODE,ZENER
D528	BZ410021	D97U05R61B	DIODE,ZENER
D601	BZ410006	D1VT001330	DIODE,SILICON
D602	BZ410058	D97U08R21B	DIODE,ZENER
D604	AD300070	D97U01201B	DIODE,ZENER
D605	BZ410006	D1VT001330	DIODE,SILICON
D606	BZ410006	D1VT001330	DIODE,SILICON
D607	BZ410006	D1VT001330	DIODE,SILICON
D608	BZ410043	D2WT011E10	DIODE,SILICON
D701	AD300070	D97U01201B	DIODE,ZENER
D702	AD300070	D97U01201B	DIODE,ZENER
D703	AD300070	D97U01201B	DIODE,ZENER
D704	AD300070	D97U01201B	DIODE,ZENER
D705	AD300070	D97U01201B	DIODE,ZENER
D706	AD300070	D97U01201B	DIODE,ZENER
D709	BZ410066	D97U06R21B	DIODE,ZENER
D801	BZ410006	D1VT001330	DIODE,SILICON
D802	BZ410006	D1VT001330	DIODE,SILICON
D803	BZ410006	D1VT001330	DIODE,SILICON
D804	BZ410006	D1VT001330	DIODE,SILICON
D805	BZ410006	D1VT001330	DIODE,SILICON
D806	BZ410006	D1VT001330	DIODE,SILICON
D807	BZ410006	D1VT001330	DIODE,SILICON
D808	BZ410006	D1VT001330	DIODE,SILICON
D809	BZ410006	D1VT001330	DIODE,SILICON
D852	BZ410006	D1VT001330	DIODE,SILICON
D853	BZ410006	D1VT001330	DIODE,SILICON
D854	BZ410006	D1VT001330	DIODE,SILICON
D855	BZ410006	D1VT001330	DIODE,SILICON
D856	BZ410006	D1VT001330	DIODE,SILICON
D857	AE006060	D28T0ERB20	DIODE,RECTIFIER
D858	AE006060	D28T0ERB20	DIODE,RECTIFIER
<b>ICS</b>			
IC101	AE006067	I56F07090B	IC
IC199	AE006301	A3M6096015	INIT DATA
IC301	AE006297	I0QJ021500	IC
			OEC7090B
			BR24L16FJ-WE2
			NJM2150AM(TE1)

# ELECTRICAL REPLACEMENT PARTS LIST

Location No.	TSB P/N	Reference No.	Description
			<b>ICs</b>
IC302	AD301983	I01FF58910	IC AN5891SA-E1V
△IC401	BZ611117	I03TD80410	IC LA78041
△IC504	BZ410088	0002E00610	PHOTO COUPLER LTV-817M-VB
IC601	AE002803	I06FC1283A	IC M61283FP R70T
IC701	AD301988	I0UF015010	IC MM1501XNRE
IC702	AD301988	I0UF015010	IC MM1501XNRE
IC902	BZ611068	I01FF58290	IC AN5829S
△IC1001	AE003081	I0FSP7808B	IC AN17808B
IC1501	AE003002	I03FE76605	IC LA76605M-TLM
IC1502	AD301988	I0UF015010	IC MM1501XNRE
IC1503	AD301988	I0UF015010	IC MM1501XNRE
			<b>TRANSISTORS</b>
Q101	BZ510109	TCAA3875SY	TRANSISTOR,SILICON KTC3875S_Y_RTK
Q103	BZ510109	TCAA3875SY	TRANSISTOR,SILICON KTC3875S_Y_RTK
△Q402	BZ510097	TCAT03227Y	TRANSISTOR,SILICON KTC3227_Y-AT
△Q405	AD302136	TD50026380	TRANSISTOR,SILICON 2SD2638(OEC)
Q408	BZ510073	TAATA12660	TRANSISTOR,SILICON KTA1266-AT(Y,GR)
Q409	BZ510073	TAATA12660	TRANSISTOR,SILICON KTA1266-AT(Y,GR)
Q410	BZ510110	TC30041590	TRANSISTOR,SILICON 2SC4159(D,E)
Q411	BZ510109	TCAA3875SY	TRANSISTOR,SILICON KTC3875S_Y_RTK
△Q502	BZ510098	T220033260	FET 2SK3326(2)
△Q503	BZ510005	TA3T1371A0	TRANSISTOR,SILICON 2SA1371(D,E)-AE
Q504	BZ510069	TCATC31980	TRANSISTOR,SILICON KTC3198-AT(Y,GR)
△Q505	BZ510011	TC3T029090	TRANSISTOR,SILICON 2SC2909(S,T)-AA
△Q507	BZ510069	TCATC31980	TRANSISTOR,SILICON KTC3198-AT(Y,GR)
△Q508	BZ510077	TAAT012714	TRANSISTOR,SILICON KTA1271_Y-AT
Q509	BZ510069	TCATC31980	TRANSISTOR,SILICON KTC3198-AT(Y,GR)
△Q512	BZ510004	TA3T016240	TRANSISTOR,SILICON 2SA1624-AA
△Q514	BZ510070	TCAT032034	TRANSISTOR,SILICON KTC3203_Y-AT
Q601	BZ510105	TCAT03209Y	TRANSISTOR,SILICON KTC3209_Y-AT
Q602	BZ510105	TCAT03209Y	TRANSISTOR,SILICON KTC3209_Y-AT
Q603	BZ510109	TCAA3875SY	TRANSISTOR,SILICON KTC3875S_Y_RTK
Q604	BZ510105	TCAT03209Y	TRANSISTOR,SILICON KTC3209_Y-AT
Q605	BZ510109	TCAA3875SY	TRANSISTOR,SILICON KTC3875S_Y_RTK
Q606	BZ510105	TCAT03209Y	TRANSISTOR,SILICON KTC3209_Y-AT
Q607	BZ510070	TCAT032034	TRANSISTOR,SILICON KTC3203_Y-AT
Q610	BZ510109	TCAA3875SY	TRANSISTOR,SILICON KTC3875S_Y_RTK
Q611	BZ510105	TCAT03209Y	TRANSISTOR,SILICON KTC3209_Y-AT
Q613	BZ510109	TCAA3875SY	TRANSISTOR,SILICON KTC3875S_Y_RTK
Q614	BZ510108	TAAA1504SY	TRANSISTOR,SILICON KTA1504S_Y_RTK
Q709	BZ510108	TAAA1504SY	TRANSISTOR,SILICON KTA1504S_Y_RTK
Q711	BZ510109	TCAA3875SY	TRANSISTOR,SILICON KTC3875S_Y_RTK
Q712	BZ510109	TCAA3875SY	TRANSISTOR,SILICON KTC3875S_Y_RTK
△Q801	BZ510091	TCA0042170	TRANSISTOR,SILICON KTC4217(O,Y)
△Q802	BZ510091	TCA0042170	TRANSISTOR,SILICON KTC4217(O,Y)
△Q803	BZ510091	TCA0042170	TRANSISTOR,SILICON KTC4217(O,Y)
△Q810	BZ510100	TCATC3199Y	TRANSISTOR,SILICON KTC3199_Y-AT
△Q811	BZ510100	TCATC3199Y	TRANSISTOR,SILICON KTC3199_Y-AT
△Q812	BZ510100	TCATC3199Y	TRANSISTOR,SILICON KTC3199_Y-AT
Q852	BZ510069	TCATC31980	TRANSISTOR,SILICON KTC3198-AT(Y,GR)
Q853	AD300024	TCUJ00752Y	TRANSISTOR,SILICON 2SC752(G)(TM)_Y
Q854	BZ510069	TCATC31980	TRANSISTOR,SILICON KTC3198-AT(Y,GR)
Q855	BZ510069	TCATC31980	TRANSISTOR,SILICON KTC3198-AT(Y,GR)
Q856	BZ510069	TCATC31980	TRANSISTOR,SILICON KTC3198-AT(Y,GR)
Q857	BZ510073	TAATA12660	TRANSISTOR,SILICON KTA1266-AT(Y,GR)
Q858	AD300029	TAU0018370	TRANSISTOR,SILICON 2SA1837
Q859	AD300025	TCU0047930	TRANSISTOR,SILICON 2SC4793
Q901	BZ510108	TAAA1504SY	TRANSISTOR,SILICON KTA1504S_Y_RTK
Q902	BZ510108	TAAA1504SY	TRANSISTOR,SILICON KTA1504S_Y_RTK
Q1001	BZ510068	TNAAJ05003	COMPOUND TRANSISTOR KRC111SRTK
Q1503	BZ510109	TCAA3875SY	TRANSISTOR,SILICON KTC3875S_Y_RTK
Q1504	BZ510109	TCAA3875SY	TRANSISTOR,SILICON KTC3875S_Y_RTK
Q1507	BZ510109	TCAA3875SY	TRANSISTOR,SILICON KTC3875S_Y_RTK
Q1508	BZ510109	TCAA3875SY	TRANSISTOR,SILICON KTC3875S_Y_RTK
			<b>COILS &amp; TRANSFORMERS</b>
L301	BZ310041	02167F101J	COIL 100 UH
L401	AD301644	021L75472J	COIL 4.7 MH
L402	BZ310187	022100034A	COIL,LINEARITY ELH5L4132N
L403	AD301606	02DK000058	COIL,CHOKE 02DK000058
△L501	AD301124	029T000101	COIL,LINE FILTER 2R2A752F28Y
△L503	BZ310188	028R250009	COIL,DEGAUSS 8R250009

# ELECTRICAL REPLACEMENT PARTS LIST

Location No.	TSB P/N	Reference No.	Description
<b>COILS &amp; TRANSFORMERS</b>			
L601	AD301990	021LA6330J	COIL 33 UH
L802	BZ310170	021673151K	COIL 150 UH
L803	BZ310170	021673151K	COIL 150 UH
L804	BZ310170	021673151K	COIL 150 UH
L901	BZ310041	02167F101J	COIL 100 UH
L1501	BZ310041	02167F101J	COIL 100 UH
L1502	AD301417	02167F221J	COIL 220 UH
L1503	AD301417	02167F221J	COIL 220 UH
L1505	AD300613	02167F150J	COIL 15 UH
L1508	BZ310041	02167F101J	COIL 100 UH
L1510	AD300613	02167F150J	COIL 15 UH
L1511	AD300613	02167F150J	COIL 15 UH
L1512	BZ310183	021LA6220J	COIL 22 UH
T401	BZ310189	0450190161	TRANS,HORIZONTAL DRIVE ETH19Y203AY
△T501	AD301034	048140066S	TRANSFORMER,SWITCHING 8140066S
<b>JACKS</b>			
J701	AE002759	060J431020	RCA JACK MSP-213V2-432_NI_LF
J702	AE006074	063Q700011	JACK YKF51-5503N
J703	AE002759	060J431020	RCA JACK MSP-213V2-432_NI_LF
J704	AE002761	060J411032	RCA JACK MSP-213V1-652_NI_LF
J705	AE004756	060J401104	RCA JACK MTJ-032-03A-30FE
J706	AE004758	060J401106	RCA JACK MTJ-032-03A-32FE
J707	AE004757	060J401105	RCA JACK MTJ-032-03A-31FE
J708	AE002759	060J431020	RCA JACK MSP-213V2-432_NI_LF
△J801	AD301936	066F130021	SOCKET,CATHODE RAY,TUBE ISHS62S
△J1001	AE003431	060J131016	HEADPHONE JACK MSJ-2000_AG
<b>SWITCHES</b>			
SW101	BZ612010	0504101T34	SWITCH,TACT EVQ21505R
SW102	BZ612010	0504101T34	SWITCH,TACT EVQ21505R
SW103	BZ612010	0504101T34	SWITCH,TACT EVQ21505R
SW104	BZ612010	0504101T34	SWITCH,TACT EVQ21505R
SW105	BZ612010	0504101T34	SWITCH,TACT EVQ21505R
<b>VARIABLE RESISTORS</b>			
VR401	BZ210218	V1K63H3BTE	VOLUME,SEMI FIXED NVG6TLTAB222
VR502	BZ210101	V1163H4BTC	VOLUME,SEMI FIXED EVNCYAA03BE4
<b>P.C.BOARD ASSEMBLIES</b>			
PCB010	AE006302	A3M6096010	PCB ASS'Y CMD016A
PCB060	AE006299	A3M6086060	PCB ASS'Y CED037A
PCB110	AE006300	A3M6086110	PCB ASS'Y CCD014A
<b>MISCELLANEOUS</b>			
B401	BZ310129	024HT03564	CORE,BEADS W4BRH3.5X6X1.0
B402	BZ310129	024HT03564	CORE,BEADS W4BRH3.5X6X1.0
B405	BZ310129	024HT03564	CORE,BEADS W4BRH3.5X6X1.0
B501	BZ310045	024AT03481	CORE,BEADS BL02RN1-R62T2
B504	BZ310121	024HT03553	CORE,BEADS W5RH3.5X5X1.0
B851	BZ310121	024HT03553	CORE,BEADS W5RH3.5X5X1.0
B852	BZ310121	024HT03553	CORE,BEADS W5RH3.5X5X1.0
B853	BZ310121	024HT03553	CORE,BEADS W5RH3.5X5X1.0
BT001	AE005640	141R004016	BATTERY,MANGAN GR03X-SP2
BT002	AE005640	141R004016	BATTERY,MANGAN GR03X-SP2
△CD501	AE006077	1209615904	CORD,AC BUSH 9615904
CD801	BZ614484	06CU253401	CORD,CONNECTOR CU253401
CD802	AE000423	06CU274501	CORD,CONNECTOR CU274501
CD803	AE005222	06C383037A	CORD,CONNECTOR C383037A
CD851	AD302371	06CU244701	CORD,CONNECTOR CU244701
CD852	AD301043	06CU232001	CORD,CONNECTOR CU232001
CP101	BZ614102	0694270139	CONNECTOR PCB SIDE 173979-7
△CP401	AE006075	069X460109	CONNECTOR PCB SIDE B06B-DVS-L (LF)
△CP501	BZ614176	069S320419	CONNECTOR PCB SIDE A3963WV2-3PD
△CP502	BZ614283	069S420110	CONNECTOR PCB SIDE A1561WV2-2P
CP507	BZ614444	069D01001A	CONNECTOR PCB SIDE 003P-2100
CP508	BZ614444	069D01001A	CONNECTOR PCB SIDE 003P-2100
CP803	AD301996	069S330010	CONNECTOR PCB SIDE A2361WV2-3P
CP804	BZ614058	069W010010	CONNECTOR PCB SIDE 005P-2100
CP852	BZ614350	069S230629	CONNECTOR PCB SIDE A2001WV2-3P
CD1001	AE006213	06C3146903	CORD,CONNECTOR C3146903
CP1001	AD301045	069S140419	CONNECTOR PCB SIDE A2502WV2-4P
CP801A	BZ614276	067U005049	WIRE HOLDER B2013H02-5P
CP801B	AD300752	069S250629	CONNECTOR PCB SIDE A2001WV2-5P
CP802A	AD301997	067U007029	WIRE HOLDER B2013H02-7P
CP802B	BZ614485	069S270629	CONNECTOR PCB SIDE A2001WV2-7P

# ELECTRICAL REPLACEMENT PARTS LIST

Location No.	TSB P/N	Reference No.	Description
<b>MISCELLANEOUS</b>			
CP851A	BZ614334	067U004029	WIRE HOLDER B2013H02-4P
CP851B	AD301998	069S240629	CONNECTOR PCB SIDE A2001WV2-4P
CP852B	BZ614349	067U003029	WIRE HOLDER B2013H02-3P
EL001	BZ614044	124120301A	EYE LET XRY20X30BD
EL002	BZ614043	124116281A	EYE LET XRY16X28BD
△F501	BZ614422	081PC6R305	FUSE 51MS063L
△FB401	AE003085	043224007F	TRANSFORMER,FLYBACK FSU24A001_M
FH501	AE002634	06710T0009	HOLDER,FUSE EYF-52BCY
FH502	AE002634	06710T0009	HOLDER,FUSE EYF-52BCY
OS101	AD301048	0773071001	REMOTE RECEIVER RPM7138-WH5
△RY501	AE006070	0560X20118	RELAY G5PA-1-SA(WEC)
△SP1001	AD301050	070C457003	SPEAKER SG05K07BRA
△SP1002	AD301050	070C457003	SPEAKER SG05K07BRA
△TH501	BZ410079	DF5EL3R0A0	DEGAUSS ELEMENT ZPB45BL3R0A
TM101	AE003009	076R0GW020	TRANSMITTER R25-1943
△TU001	AE006069	0163300018	RF UNIT 115-V-KA35ARB
△V801	AE003574	098W250402	CRT W/DY A60LVY196X11(OL)
X101	AD302002	100CT8R005	CRYSTAL HC-49/U-S
X602	BZ613004	100CT3R505	CRYSTAL HC-49/U

**RESISTOR**

RC..... CARBON RESISTOR

**CAPACITORS**

CC..... CERAMIC CAPACITOR  
 CE..... ALUMI ELECTROLYTIC CAPACITOR  
 CP..... POLYESTER CAPACITOR  
 CPP..... POLYPROPYLENE CAPACITOR  
 CPL..... PLASTIC CAPACITOR  
 CMP..... METAL POLYESTER CAPACITOR  
 CMPL..... METAL PLASTIC CAPACITOR  
 CMPP..... METAL POLYPROPYLENE CAPACITOR

# **TOSHIBA CORPORATION**

1-1, SHIBAURA 1-CHOME, MINATO-KU, TOKYO 105-8001, JAPAN