

# SERVICE MANUAL

# AA-2 CHASSIS

<u>MODEL</u>	<u>COMMANDER</u>	<u>DEST.</u>	<u>CHASSIS NO.</u>	<u>MODEL</u>	<u>COMMANDER</u>	<u>DEST.</u>	<u>CHASSIS NO.</u>
KV-27V20	RM-Y135	US	SCC-J71H-A	KV-29V65M	RM-Y137	E	SCC-J74J-A
KV-27V20	RM-Y135	Canadian	SCC-J73G-A	KV-29V75M	RM-Y137	E	SCC-J74K-A
KV-27V25	RM-Y137	US	SCC-J71J-A	KV-32V25	RM-Y137	US	SCC-J71L-A
KV-27V25	RM-Y137	Canadian	SCC-J73H-A	KV-32V25	RM-Y137	Canadian	SCC-J73K-A
KV-27V35	RM-Y137	US	SCC-J71K-A	KV-32V35	RM-Y137	US	SCC-J71M-A
KV-27V35	RM-Y137	Canadian	SCC-J73J-A	KV-32V35	RM-Y137	Canadian	SCC-J73L-A
KV-29V20M	RM-Y135	E	SCC-J74H-A	KV-34V35C	RM-Y137	E	SCC-J74M-A
KV-29V35C	RM-Y137	E	SCC-J74L-A				

Note :

1. Adjustment Manual for this model is separately published.

Adjustment Manual	
Part No.	9-965-822-01

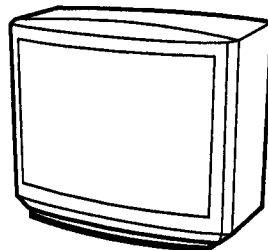
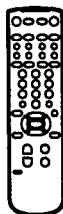

KV-27V20/27V25/29V20M  
29V65M/32V25

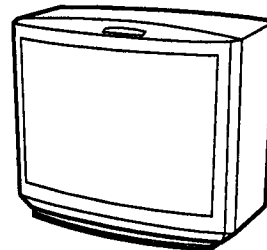

KV-27V35/29V35C/29V75M  
32V35/34V35C



TRINITRON® COLOR TV  
**SONY®**

※ Please file according to model size. ....

27 29 32 34

# SPECIFICATIONS

Model number	KV-27V20	KV-27V25	KV-27V35	KV-29V20M	KV-29V35C	KV-29V65M	KV-29V75M	KV-32V25	KV-32V35	KV-34V35C	
<b>Television system</b>	American TV standard										
<b>Channel coverage</b>	VHF: 2-13 / UHF: 14-69 / CATV: 1-125										
<b>Antenna</b>	75-ohm external antenna terminal for VHF/UHF										
<b>Picture tube</b>	Hi Black Trinitron® tube										
<b>Screen size (in.)</b>	27-inch picture measured diagonally							32-inch picture measured diagonally			
<b>Power requirements</b>	120 V, 60 Hz	120 V, 60 Hz	120 V, 60 Hz	120 V, 60 Hz	220 V, 50/60Hz	120 V, 60 Hz	120 V, 60 Hz	120 V, 60 Hz	120 V, 60 Hz	220 V, 50/60Hz	
<b>Number of inputs/outputs</b>											
<b>Video<sup>1)</sup></b>	2	3	3	2	3	3	3	3	3	3	
<b>S video<sup>2)</sup></b>	1	1	1	1	1	1	1	1	2	2	
<b>Audio<sup>3)</sup></b>	2	3	3	2	3	3	3	3	3	3	
<b>Audio out<sup>4)</sup></b>	1	1	1	1	1	1	1	1	1	1	
<b>Monitor out<sup>1)</sup></b>	1	1	1	1	1	1	1	1	1	1	
<b>TV out<sup>1)</sup></b>	-	-	1	-	1	-	1	-	1	1	
<b>S-Link</b>	-	•	•	-	•	•	•	•	•	•	
<b>Speaker output (W)</b>	5W × 2	5W × 2	10W × 2	5W × 2	10W × 2	5W × 2	10W × 2	5W × 2	10W × 2	10W × 2	
<b>Power consumption (W)</b>											
<b>When in use (Max.)</b>	165W	180W	195W	165W	195W	180W	195W	190W	210W, 2.75 A	210W	
<b>In standby</b>	9W	9W	13W	9W	13W	9W	13W	9W	13W	13W	
<b>Dimensions (W/H/D) (mm) (in.)</b>	660.4 × 602.5 × 521.2 mm 26 × 23 <sup>3</sup> / <sub>4</sub> × 20 <sup>5</sup> / <sub>8</sub> in.	690 × 575.4 × 503.4 mm 27 <sup>1</sup> / <sub>4</sub> × 22 <sup>3</sup> / <sub>4</sub> × 19 <sup>7</sup> / <sub>8</sub> in.	690 × 575.4 × 503.4 mm 27 <sup>1</sup> / <sub>4</sub> × 22 <sup>3</sup> / <sub>4</sub> × 19 <sup>7</sup> / <sub>8</sub> in.	660.4 × 602.5 × 521.2 mm 26 × 23 <sup>3</sup> / <sub>4</sub> × 20 <sup>5</sup> / <sub>8</sub> in.	690 × 575.4 × 503.4 mm 27 <sup>1</sup> / <sub>4</sub> × 22 <sup>3</sup> / <sub>4</sub> × 19 <sup>7</sup> / <sub>8</sub> in.	690 × 575.4 × 503.4 mm 27 <sup>1</sup> / <sub>4</sub> × 22 <sup>3</sup> / <sub>4</sub> × 19 <sup>7</sup> / <sub>8</sub> in.	690 × 575.4 × 503.4 mm 27 <sup>1</sup> / <sub>4</sub> × 22 <sup>3</sup> / <sub>4</sub> × 19 <sup>7</sup> / <sub>8</sub> in.	821 × 675.3 × 587 mm 33 <sup>1</sup> / <sub>2</sub> × 27 <sup>5</sup> / <sub>8</sub> × 24 in.	821 × 675.3 × 587 mm 33 <sup>1</sup> / <sub>2</sub> × 27 <sup>5</sup> / <sub>8</sub> × 24 in.	821 × 675.3 × 587 mm 33 <sup>1</sup> / <sub>2</sub> × 27 <sup>5</sup> / <sub>8</sub> × 24 in.	
<b>Mass (kg) (lbs)</b>	40.6 kg 89 lbs 8 oz	43 kg 94 lbs 13 oz	43 kg 94 lbs 13 oz	40.6 kg 89 lbs 8 oz	43 kg 94 lbs 13 oz	43 kg 94 lbs 13 oz	43 kg 94 lbs 13 oz	43 kg 94 lbs 13 oz	70 kg 154 lbs 6 oz	70 kg 154 lbs 6 oz	

- <sup>1)</sup> 1 Vp-p, 75 ohms unbalanced, sync negative
- <sup>2)</sup> Y: 1 Vp-p, 75 ohms unbalanced, sync negative  
C: 0.286 Vp-p (Burst signal), 75 ohms
- <sup>3)</sup> 500 mVrms (100% modulation), Impedance: 47 kilohms
- <sup>4)</sup> More than 408 mVrms at the maximum volume setting (variable)  
More than 408 mVrms (fix)  
Impedance: 5 kilohms

## Supplied accessories

Remote commander RM-Y135 (1) (KV-27V20/29V20M only)

RM-Y137 (1) (KV-27V25/27V35/29V35C/  
29V65M/29V75M/32V25/32V35/  
34V35C/35V35/35V45/35V75  
only)

Size AA (R6) battery (2)

## Optional accessories

Connecting cables VMC-810S/820S, VMC-720M, YC-15V/30V, RK-74A

TV Stand SU-27A (KV-27V20/27V25/27V35/29V20M/29V35C/  
29V65M/29V75M only)

TV Stand SU-32A (KV-32V25/32V35/34V35C only)

TV Stand SU-35A (KV-35V35/35V45 only)

U/V mixer EAC-66

Design and specifications are subject to change without notice.

## (●)® SRS (SOUND RETRIEVAL SYSTEM)

The (●) SRS (SOUND RETRIEVAL SYSTEM) is manufactured by Sony Corporation under license from SRS Labs, Inc. It is covered by U.S. Patent No. 4,748,669. Other U.S. and foreign patents pending.

The word 'SRS' and the SRS symbol (●) are registered trademarks of SRS Labs, Inc.

## SAFETY CHECK-OUT (US Model only)

After correcting the original service problem, perform the following safety checks before releasing the set to the customer:

1. Check the area of your repair for unsoldered or poorly-soldered connections. Check the entire board surface for solder splashes and bridges.
2. Check the interboard wiring to ensure that no wires are "pinched" or contact high-wattage resistors.
3. Check that all control knobs, shields, covers, ground straps, and mounting hardware have been replaced. Be absolutely certain that you have replaced all the insulators.
4. Look for unauthorized replacement parts, particularly transistors, that were installed during a previous repair. Point them out to the customer and recommend their replacement.
5. Look for parts which, though functioning, show obvious signs of deterioration. Point them out to the customer and recommend their replacement.
6. Check the line cords for cracks and abrasion. Recommend the replacement of any such line cord to the customer.
7. Check the B+ and HV to see if they are at the values specified. Make sure your instruments are accurate; be suspicious of your HV meter if sets always have low HV.
8. Check the metal trim, metallized knobs, screws, and all other exposed metal parts for AC leakage.  
Check leakage as described below.

### LEAKAGE TEST

The AC leakage from any exposed metal part to earth ground and from all exposed metal parts to any exposed metal part having a return to chassis, must not exceed 0.5mA (500 microampers). Leakage current can be measured by any one of three methods.

1. A commercial leakage tester, such as the Simpson 229 or RCA WT-540A. Follow the manufactures' instructions to use these instruments.
2. A battery-operated AC milliammeter. The Data Precision 245 digital multimeter is suitable for this job.
3. Measuring the voltage drop across a resistor by means of a VOM or battery-operated AC voltmeter. The "limit" indication is 0.75V, so analog meters must have an accurate low-voltage scale. The Simpson 250 and Sanwa SH-63Trd are examples of a passive VOM that is suitable. Nearly all battery operated digital multimeters that have a 2V AC range are suitable. (See Fig. A)

### HOW TO FIND A GOOD EARTH GROUND

A cold-water pipe is guaranteed earth ground; the cover-plate retaining screw on most AC outlet boxes is also at earth ground. If the retaining screw is to be used as your earth-ground, verify that it is at ground by measuring the resistance between it and a cold-water pipe with an ohmmeter. The reading should be zero ohms. If a cold-water pipe is not accessible, connect a 60-100 watts trouble light (not a neon lamp) between the hot side of the receptacle and the retaining screw. Try both slots, if necessary, to locate the hot side of the line, the lamp should light at normal brilliance if the screw is at ground potential. (See Fig. B)

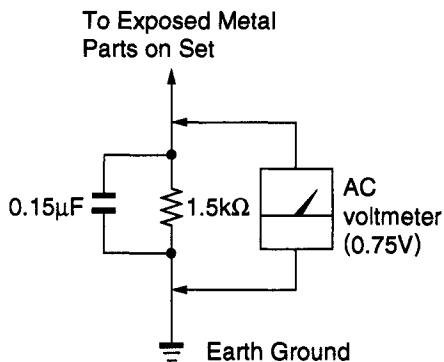

Fig. A. Using an AC voltmeter to check AC leakage.

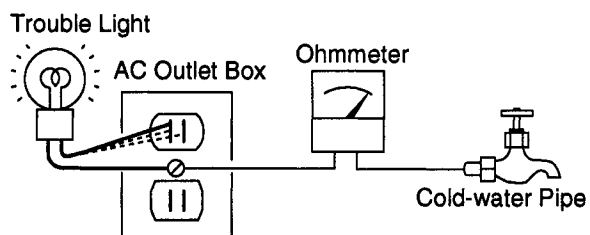

Fig. B. Checking for earth ground.

# TABLE OF CONTENTS

<u>Section</u>	<u>Title</u>	<u>Page</u>	<u>Section</u>	<u>Title</u>	<u>Page</u>
<b>1. GENERAL</b>			<b>2. DISASSEMBLY</b>		
Welcome! .....		5	2-1. Rear Cover Removal .....		22
Checking your model number .....		5	2-2. Chassis Assy Removal .....		22
Step 1: Hookup .....		5	2-3. Service Position .....		22
Step 2: Installing the glass door and adjusting the shelf .....		9	2-4. Control Switch Removal (KV-27V35/29V35C/29V75M/32V35/34V35C) ...		22
Step 3: Setting up the remote commander .....		10	2-5. Picture Tube Removal (KV-27V20/27V25/ 27V35/29V20M/29V35C/29V65M/29V75M) .....		23
Step 4: Setting up the TV automatically (AUTO SET UP) ...		10	2-6. Picture Tube Removal (KV-32V25/32V35/34V35C) .....		23
Changing the menu language .....		12	<b>3. SAFETY RELATED ADJUSTMENTS</b> .....		
Adjusting the tilt of the picture (TILT CORRECTION) .....		12	<b>4. DIAGRAMS</b>		
Watching the TV .....		12	4-1. Block Diagrams .....		27
Watching two programs at a time-PIP .....		13	4-2. Circuit Boards Location .....		35
Adjusting the picture (VIDEO) .....		14	4-3. Printed Wiring Boards and Schematic Diagrams ...		35
Selecting the video mode (VIDEO) .....		14	• P Board .....		36
Adjusting picture brightness automatically (LIGHTSENSOR) .....		15	• SC Board .....		39
Adjusting the sound (AUDIO) .....		15	• A Board .....		41
Using audio effect (EFFECT) .....		15	• UV Board .....		47
Selecting stereo or bilingual programs (MTS) .....		16	• WB, SC Boards .....		52
Setting the speaker switch (SPEAKER) .....		16	• HV, HS Boards .....		55
Setting audio out (AUDIO OUT) .....		16	• C, G Boards .....		59
Setting daylight saving time (DAYLIGHT SAVING) .....		17	• AV, K Board .....		64
Setting the clock (CURRENT TIME SET) .....		17	4-4. Semiconductors .....		70
Setting the timer to turn the TV on and off (ON/OFF TIMER) .....		17	<b>5. EXPLODED VIEWS</b>		
Customizing the channel names (CHANNEL CAPTION) ...		18	5-1. Chassis (EXCEPT KV-32V25/32V35/34V35C) ....		71
Blocking out a channel (CHANNEL BLOCK) .....		18	5-2. Picture Tube (EXCEPT KV-32V25/32V35/34V35C) .....		73
Setting your favorite channels (FAVORITE CHANNEL) ....		18	5-3. Chassis (KV-32V25/32V35/34V35C) .....		74
Setting video labels (VIDEO LABEL) .....		19	5-4. Picture Tube (KV-32V25/32V35/34V35C) .....		75
Setting Caption Vision (CAPTION VISION) .....		19	<b>6. ELECTRICAL PARTS LIST</b> .....		
Operating video equipment .....		20			76
Operating a cable box DBS receiver .....		21			
Troubleshooting .....		21			

**(CAUTION)**

SHORT CIRCUIT THE ANODE OF THE PICTURE TUBE AND THE ANODE CAP TO THE METAL CHASSIS, CRT SHIELD, OR CARBON PAINTED ON THE CRT, AFTER REMOVING THE ANODE.

**WARNING!!**

AN ISOLATION TRANSFORMER SHOULD BE USED DURING ANY SERVICE TO AVOID POSSIBLE SHOCK HAZARD, BECAUSE OF LIVE CHASSIS.  
THE CHASSIS OF THIS RECEIVER IS DIRECTLY CONNECTED TO THE AC POWER LINE.

**SAFETY-RELATED COMPONENT WARNING!!**

COMPONENTS IDENTIFIED BY SHADING AND MARK  $\Delta$  ON THE SCHEMATIC DIAGRAMS, EXPLODED VIEWS AND IN THE PARTS LIST ARE CRITICAL FOR SAFE OPERATION. REPLACE THESE COMPONENTS WITH SONY PARTS WHOSE PART NUMBERS APPEAR AS SHOWN IN THIS MANUAL OR IN SUPPLEMENTS PUBLISHED BY SONY. CIRCUIT ADJUSTMENTS THAT ARE CRITICAL FOR SAFE OPERATION ARE IDENTIFIED IN THIS MANUAL. FOLLOW THESE PROCEDURES WHENEVER CRITICAL COMPONENTS ARE REPLACED OR IMPROPER OPERATION IS SUSPECTED.

**(ATTENTION)**

APRES AVOIR DECONNECTE LE CAP DE L'ANODE, COURT-CIRCUITER L'ANODE DU TUBE CATHODIQUE ET CELUI DE L'ANODE DU CAP AU CHASSIS METALLIQUE DE L'APPAREIL, OU AU COUCHE DE CARBONE PEINTE SUR LE TUBE CATHODIQUE OU AU BLINDAGE DU TUBE CATHODIQUE.

**ATTENTION!!**

AFIN D'EVITER TOUT RESQUE D'ELECTROCUTION PROVENANT D'UN CHASSIS SOUS TENSION, UN TRANSFORMATEUR D'ISOLEMENT DOIT ETRE UTILISE LORS DE TOUT DEPANNAGE. LE CHASSIS DE CE RECEPTEUR EST DIRECTEMENT RACCORDE A L'ALIMENTATION SECTEUR.

**ATTENTION AUX COMPOSANTS RELATIFS A LA SECURITE!!**

LES COMPOSANTS IDENTIFIES PAR UNE TRAME ET PAR UNE MARQUE  $\Delta$  SUR LES SCHEMAS DE PRINCIPE, LES VUES EXPLOSEES ET LES LISTES DE PIECES SONT D'UNE IMPORTANCE CRITIQUE POUR LA SECURITE DU FONCTIONNEMENT. NE LES REMPLACER QUE PAR DES COMPOSANTS SONY DONT LE NUMERO DE PIECE EST INDIQUE DANS LE PRESENT MANUEL OU DANS DES SUPPLEMENTS PUBLIES PAR SONY. LES REGLAGES DE CIRCUIT DONT L'IMPORTANCE EST CRITIQUE POUR LA SECURITE DU FONCTIONNEMENT SONT IDENTIFIES DANS LE PRESENT MANUEL. SUIVRE CES PROCEDURES LORS DE CHAQUE REMPLACEMENT DE COMPOSANTS CRITIQUES, OU LORSQU'UN MAUVAIS FONCTIONNEMENT EST SUSPECTE.

## SECTION 1 GENERAL

The operating instruction mentioned here are partial abstracts from the Operating Instruction Manual. The page numbers of the Operating Instruction Manual remain as in the manual. (Part no: 3-810-687-22)

### Welcome!

Thank you for purchasing the Sony Trinitron® Color TV. Here are some of the features you will enjoy with your TV:

- On-screen menus that let you set the picture quality, sound, and other settings.
- Picture-in-Picture (PIP) that allows you to watch another TV channel, video or cable image as a window picture.
- Surround system that simulates the sound quality of a concert hall or movie theater (KV-27S25/27S35/29RS25/29RS25C/32S25/32S35/32TW25 only).
- SRS (SOUND RETRIEVAL SYSTEM) that allows you to receive realistic sound that recaptures audio "clues" originally present but masked in the recording process so that the action seems to happen all around you (KV-27V25/27V35/29V35C/29V65M/29V75M/32V25/32V35/34V35C/35V35/35V45/35V75 only).
- LightSensor™ that automatically adjusts the brightness of the picture (KV-27V25/27V35/29V35C/29V65M/29V75M/32V25/32V35/34V35C/35V35/35V45/35V75 only).
- S-Link™ that allows you to automatically change the TV's input mode, turn on the VCR, and play a tape by just pressing the VCR's play button (KV-27V25/27V35/29V35C/29V65M/29V75M/32V25/32V35/34V35C/35V35/35V45/35V75 only). This feature is originally designed by Sony.

### Checking your model number

The instructions in this manual are for the eighteen models listed below. Before you start reading, check your model number by looking at the rear of your TV. The KV-27S25 is the model used for illustration purposes. Any differences in operation are clearly indicated in the text, for example, "KV-27S25 only."

Instructions in this manual are based on the remote commander. You can also use the controls on the TV if they have the same name as those on the remote commander.

#### Feature packages

Model number	Feature	One-tuner PIP	Two-tuner PIP	S-Link/LightSensor/SRS/Clock/Timer	Tilt correction
<b>KV-27V20</b>		•			
KV-27S35					
KV-27V25		•			
KV-27V35			•		
<b>KV-29V20</b>		•			
KV-29RS25C					
KV-29V35C			•		
KV-29V65M			•		
KV-29V75M			•		
KV-32S25		•			
KV-32S35			•		
KV-32TW25		•			
KV-32V25		•			
KV-32V35			•		
KV-34V35C			•		
KV-35V35			•		•
KV-35V45			•		•
KV-35V75			•		•

### Step 1: Hookup

Although you can use either an indoor or outdoor antenna with your TV, we recommend that you connect an outdoor antenna or a cable TV system to get better picture quality.

#### How to connect different types of cables

The illustrations below show examples of connecting cables to the TV directly.

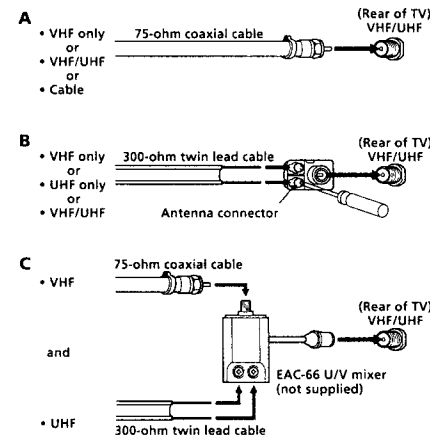

#### Notes

- Most VHF/UHF combination antennas have a signal splitter. Remove the splitter before attaching the appropriate connector.
- If you use the U/V mixer, snow and noise may appear in the picture when viewing cable TV channels over 37.

#### Connecting an antenna/cable TV system without a VCR

If your cable company requires you to connect a cable box, make the connection as follows:

##### Cable or antenna

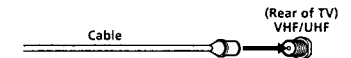

##### Cable box

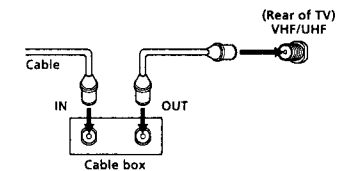

##### Cable box and cable

- KV-27S35/27V35/29V35C/29V75M/32S35/32V35/34V35C/35V35/35V45/35V75 only

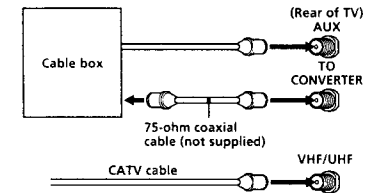

Pay cable TV systems use scrambled or encoded signals requiring a cable box\* in addition to the normal cable connection.

\* The cable box will be supplied by the cable company

#### Note

- You cannot watch the signal through AUX connector as a window picture.

##### Cable and antenna

- KV-27S35/27V35/29V35C/29V75M/32S35/32V35/34V35C/35V35/35V45/35V75 only

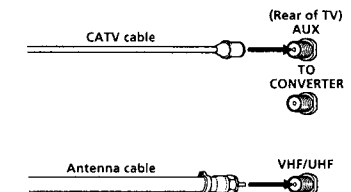

#### Note

- Do not connect anything to the TO CONVERTER connector in this case.

## Connecting an antenna/cable TV system with a VCR

To connect your VCR to the TV, first check the model number of your TV and select the corresponding connection. For details on connection, see the instruction manual of your VCR.

In order to operate PIP, a VCR must be connected to your TV and turned on (KV-27S25/27V25/29RS25/29RS25C/29V65M/32S25/32TW25/32V25 only).

Before making the connection, disconnect the AC power cords of the equipment to be connected.

After making these connections, you will be able to do the following:

- View the playback of video tapes
- Record one TV program while viewing another program
- Watch two TV programs at once using PIP

### Without a cable box

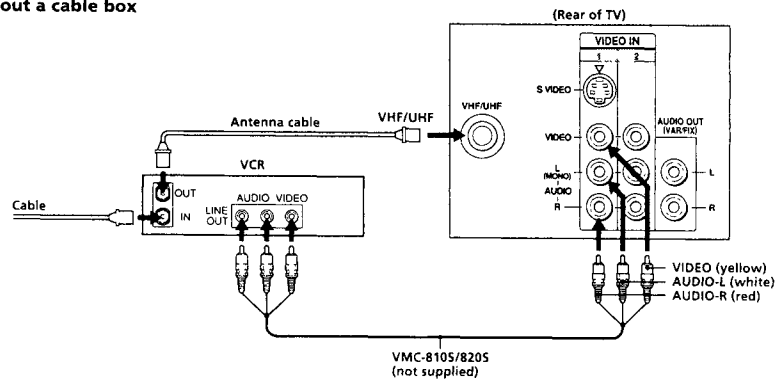

### Note

- To connect a monaural VCR, connect the audio output of the VCR to AUDIO-L (mono) of VIDEO 1 IN on the TV

### To an S video equipped VCR without a cable box

If your VCR has an S video output jack, make the following connections.

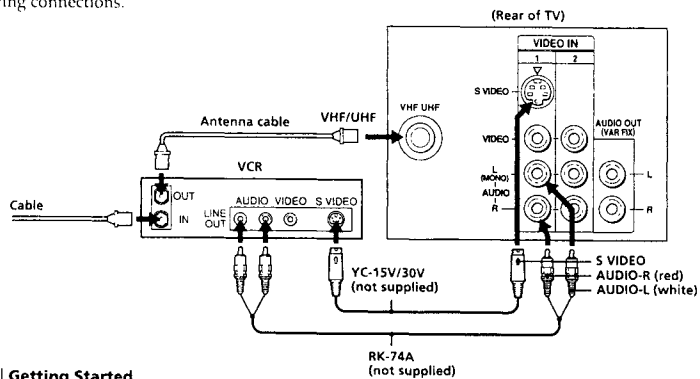

### With a cable box

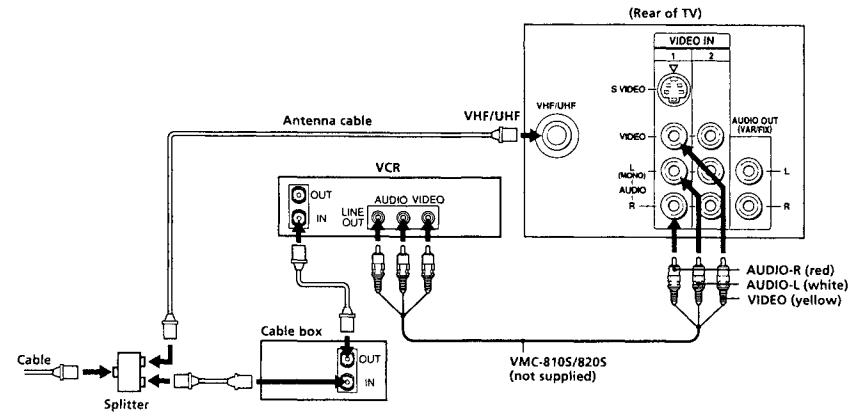

### Note

- To connect a monaural VCR, connect the audio output of the VCR to AUDIO-L (mono) of VIDEO 1 IN on the TV.

### To an S video equipped VCR with a cable box

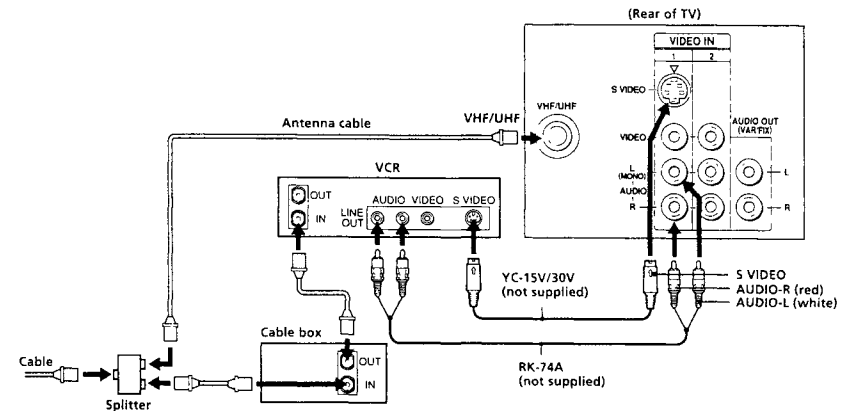

### Note

- Video signals are composed of Y (luminance) and C (chroma) signals. The S connection sends the two signals separately preventing degradation, and gives better picture quality compared to conventional connections.

## Connecting a DBS receiver

For connection details, see the instruction manual of the DBS (Digital Broadcasting Satellites) receiver.

### To a TV

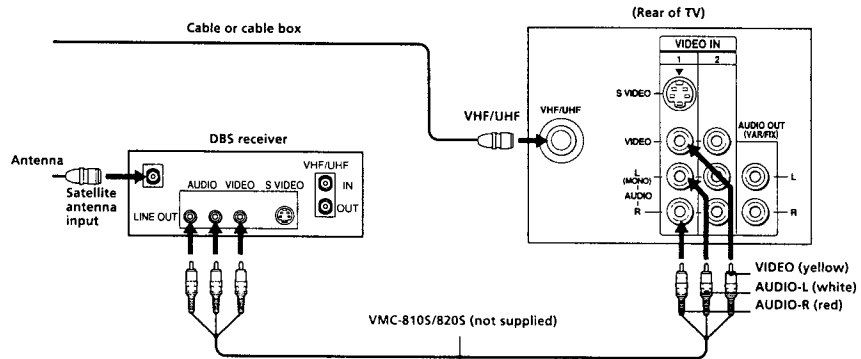

#### Note

- You can use the S VIDEO jack or the composite video jack for the video connection.

### To a TV and VCR

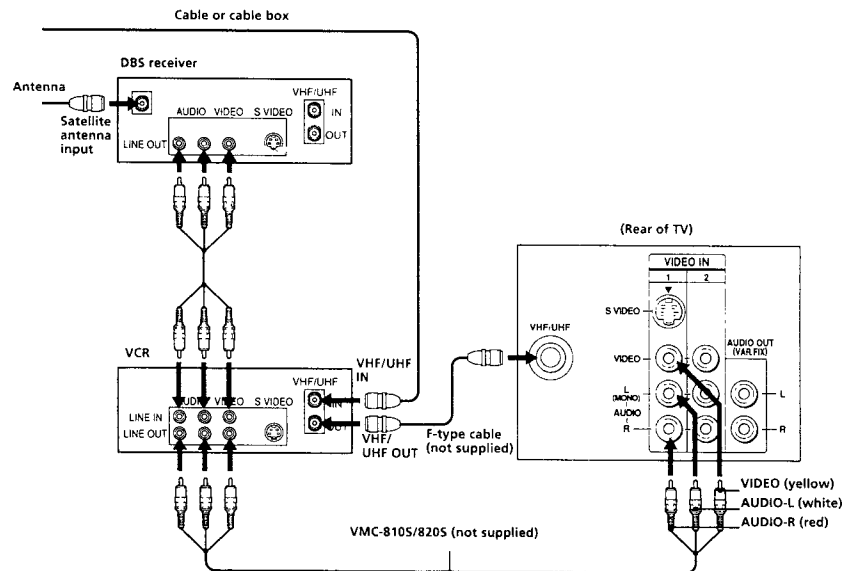

## Connecting a camcorder

■ KV-27V25/27V35/29V35C/29V65M/29V75M/32V25/32V35/34V35C/35V35/35V45/35V75 only

This connection is convenient for viewing a camcorder picture.

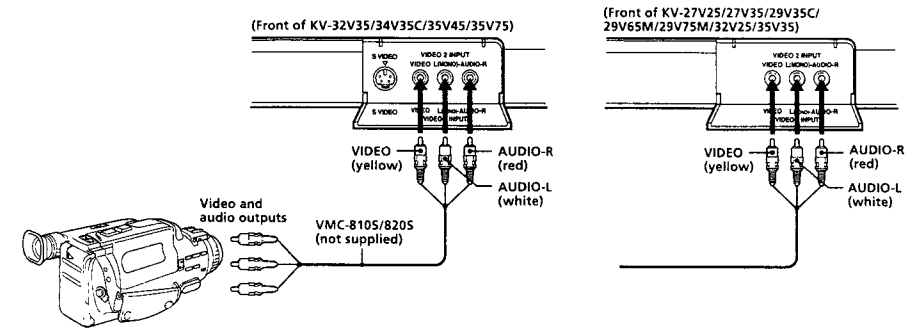

#### Note

- To connect a monaural camcorder, connect the audio output of the camcorder to AUDIO-L (mono) of VIDEO 2 INPUT on the TV.

## Connecting an audio system

When connecting audio equipment, see page 27 for more information.

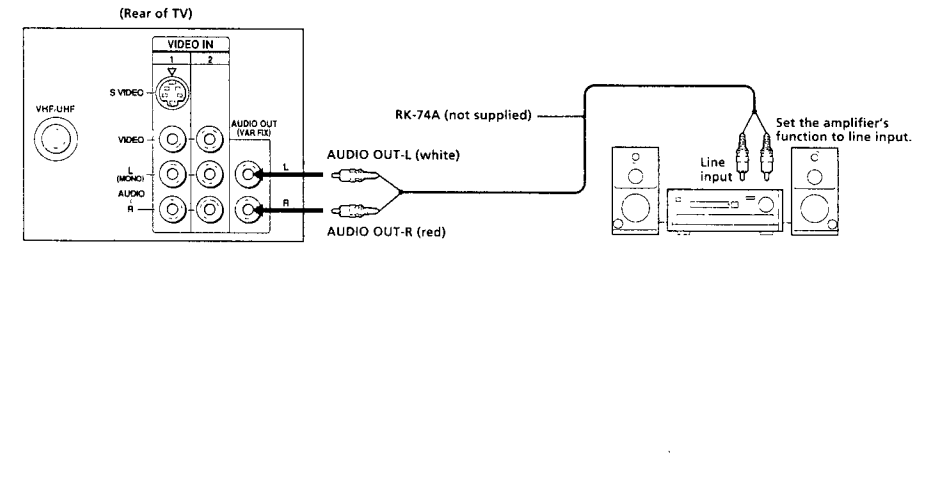

## Connecting two VCRs for tape editing using MONITOR OUT

■ KV-27V25/27V35/29V35C/29V65M/29V75M/32V25/32V35/34V35C/35V35/35V45/35V75 only

MONITOR OUT allows you to record a program that is on the screen.

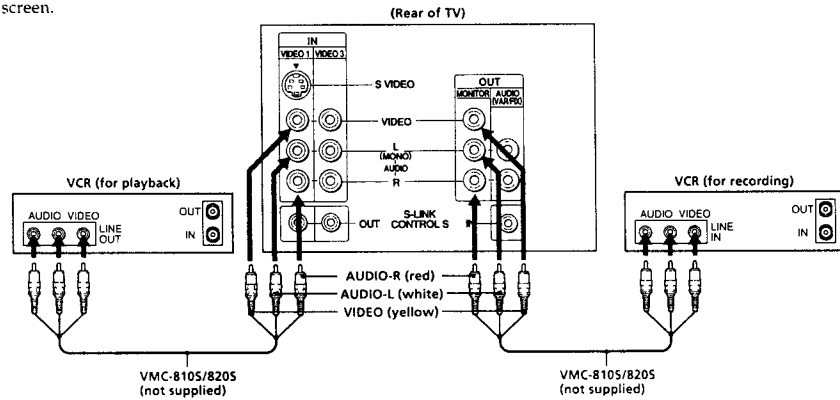

The above type of connection should only be used when you connect from the line input of one VCR, and from the line output of a second VCR.

### Notes

- Do not change the input signal while editing through MONITOR OUT, or the output signal will also change.
- You can use the S video jack to connect a VCR for playback and the composite video jack to connect a VCR for recording.

- When connecting a single VCR to the TV, do not connect the MONITOR OUT jacks at the rear of the TV to the VCR's line input, while at the same time connecting from the TV's VIDEO IN jacks to the VCR's line output, as shown below.

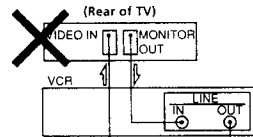

## Using the S-Link function

■ KV-27V25/27V35/29V35C/29V65M/29V75M/32V25/32V35/34V35C/35V35/35V45/35V75 only

The S-Link feature allows you to operate the TV and VCR with the S-Link function in the following ways:

- When you press the TV's play button, the TV's input mode is automatically changed to video, and the VCR starts playing a tape.

- You can turn off the TV and VCR together using the SYSTEM OFF button (see page 35 for details).

### Notes

- The TV may malfunction if you connect the S-Link cable to the TV without connecting the other end of the cable to the VCR.
- When making the S-Link connection, be sure to insert all the connectors firmly.

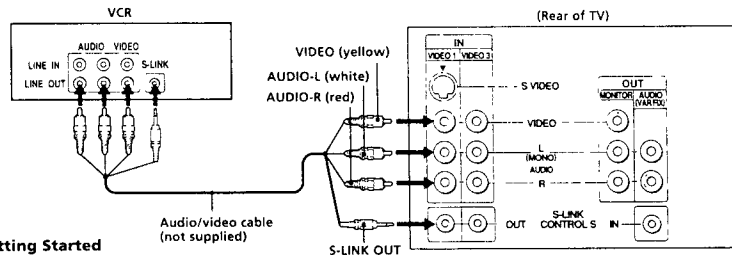

## Connecting an AV receiver

Connect an optional AV receiver to the VIDEO 1 IN jacks at the rear of the TV.

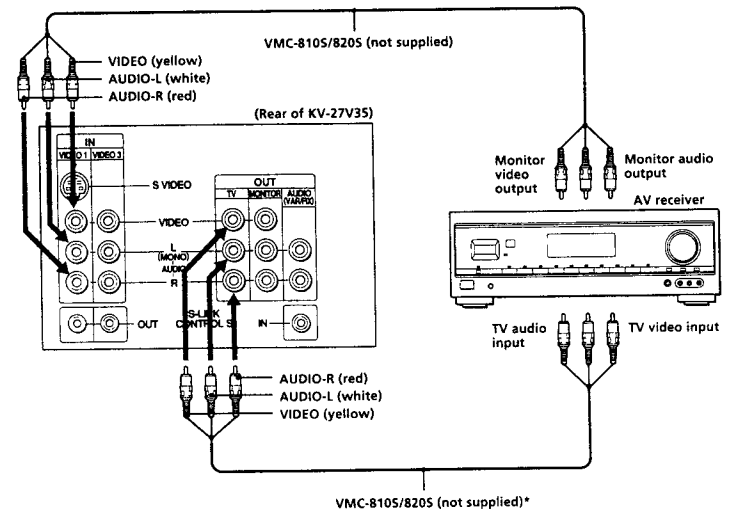

\* (KV-27V35/29V35C/29V75M/32V35/34V35C/35V45/35V75 only)

Make this connection if your TV has the TV OUT jacks. When you connect an AV receiver to the TV using the AV receiver's TV input jacks, it is recommended to set VIDEO 1 IN's video label to "RECEIVER" (see page 32 for details).

## Step 2: Installing the glass door and adjusting the shelf



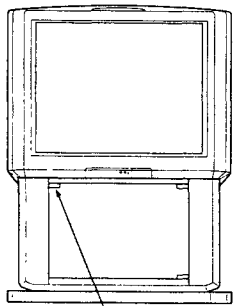

■ KV-32TW25I35V75 only

Follow these instructions to install the glass door and adjust the shelf.



Push here to close.  
To open, push again.

### Parts List

❶	Bottom hinge		1
❷	Top hinge		1
❸	Screw 4 x 4		4
❹	Plate pad		1
❺	Plate		1

### Installing the glass door

- 1 Check that the projection of the screw through the hinge allows for proper installation of the hinge to the glass door, and then insert the bottom hinge ❶ into the hole located at the bottom, right side of cabinet.

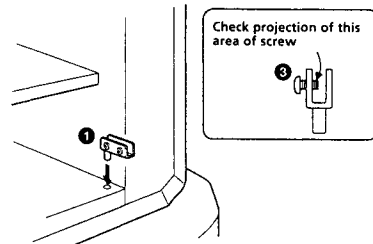

- 2 Attach the top hinge ❷ to the right side of the glass door, tighten the screws snugly, but do not overtighten. Attach the plate pad ❹ to the left side and push the plate ❺ over the plate pad.

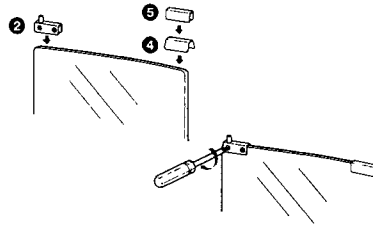

- 3 Push the top, glass door hinge into the top, right bushing and gently slide the glass door into the bottom hinge. Adjust the glass door until level, and tighten the hinge screws.

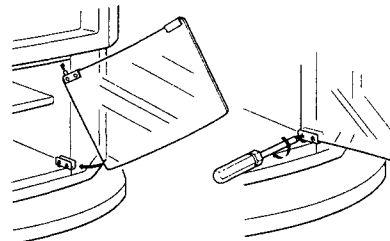

### Note

- The glass door is made of tempered glass. Although it is more shock-resistant than ordinary glass, tempered glass may shatter if it is dropped or receives a sudden shock.

### Adjusting the shelf

- 1 Unlock the four shelf supports with a medium Philips head screwdriver. Turn the screwdriver 90° to unlock the shelf supports.

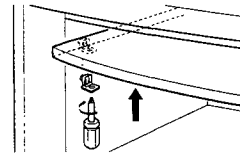

- 2 Gently slide the shelf up and out.

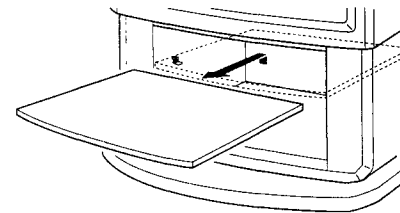

- 3 Insert shelf supports in the appropriate holes. Slide shelf in, align the shelf grooves with the shelf supports, and slide the shelf down.

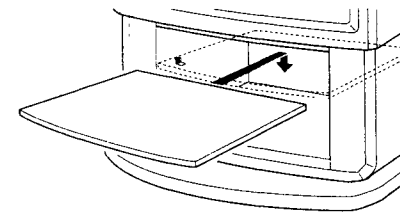

## Step 3: Setting up the remote commander

### Inserting batteries

Insert two size AA (R6) batteries (supplied) by matching the + and - on the battery to the diagram inside the battery compartment.

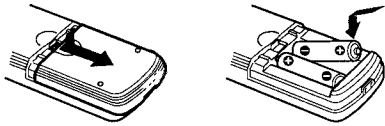

### Notes

- Under normal conditions, batteries will last up to six months. If the remote commander does not operate properly or the indicators of the buttons on the remote commander do not light up, the batteries may be worn out. When replacing batteries, replace both of them with new ones.
- Do not mix old batteries with new ones or mix different types of batteries together.
- If the electrolyte inside the battery should leak, wipe the contaminated area of the battery compartment with a cloth and replace the old batteries with new ones. To prevent the electrolyte from leaking, remove the batteries when you don't plan to use the remote commander for a long period of time.
- Do not handle the remote commander roughly. Do not drop it, step on it or let it get wet.
- Do not place the remote commander in direct sunlight, near a heater, or where the humidity is high.

### Getting to know buttons on the remote commander

Names of buttons on the remote commander are indicated in different colors to represent the available functions.

#### Button color

- Transparent ..... TV/VCR/DBS/Cable box function (light up) buttons. Press the appropriate function button first to change the remote commander's function.
- Green ..... Buttons relevant to power operations.

#### Label color

- White ..... TV/VCR/DBS/Cable box operation buttons.
- Yellow ..... PIP operation buttons.
- Blue ..... DBS operation buttons.

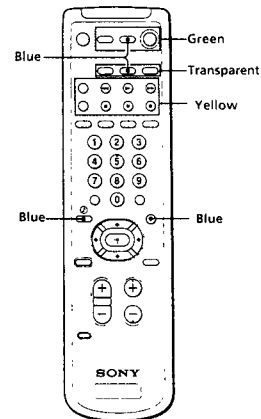

## Step 4: Setting up the TV automatically (AUTO SET UP)

You can set up your TV easily by using the AUTO SET UP feature. It presets all the receivable channels. To set up the TV manually, see "Setting cable TV on or off" (page 17) and "Presetting channels" (page 17).

#### (Front of TV)

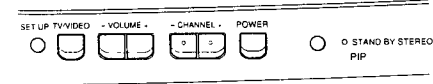

For KV-27V35/29V35C/29V75M/32V35/34V35C/35V45/35V75, the control buttons are located on the top of the TV.

**Before you start using AUTO SET UP, be sure to connect the antenna or cable to the TV (see page 5).**

### 1 Press POWER to turn on the TV.

The AUTO SET UP screen appears.



#### Note

- The AUTO SET UP screen appears whenever you press the POWER button if you do not execute AUTO PROGRAM

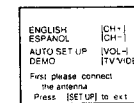

### 2 (Except Canadian models)

**Press CHANNEL + to select English screens or CHANNEL - to select Spanish screens.**

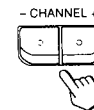

### 3 Press VOLUME -.

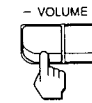

"AUTO PROGRAM" appears on the screen and the TV starts scanning and presetting channels automatically. When all the receivable channels are stored, "AUTO PROGRAM" disappears and the lowest numbered channel is displayed. If the TV receives cable TV channels, CABLE is set to ON automatically.

### To perform AUTO SET UP again

- 1 Press SET UP on the TV.
- 2 (Except Canadian models) Press CHANNEL + or CHANNEL - to select the language.
- 3 Press VOLUME -. The picture and sound settings will be set to the factory preset conditions.
- 4 Press CHANNEL +. "AUTO PROGRAM" appears on the screen and the TV starts scanning and presetting channels.
- 5 Press CHANNEL - to exit the AUTO SET UP menu.

### To exit AUTO PROGRAM

Press any button

#### Notes

- If the TV is set to a video input, you cannot execute AUTO SET UP. Press TV (black button) so that a channel number appears
- Using the AUX connector, press TV (black button) first and make sure that "AUX" is displayed beside the channel number on the screen. Then follow the procedure above to perform AUTO SET UP. (KV-27S35/27V35/29V35C/29V75M/32S35/32V35/34V35C/35V35/35V45/35V75 only)

### To browse the main functions (DEMO)

Press TV/VIDEO on the TV in step 3. The functions and menus are displayed one by one.

### To exit DEMO

Press any button

## Erasing or adding channels

After AUTO SET UP, you can erase unnecessary channels or add the channels you want. Preset channels during the day rather than late at night, when some channels may not be broadcasting.

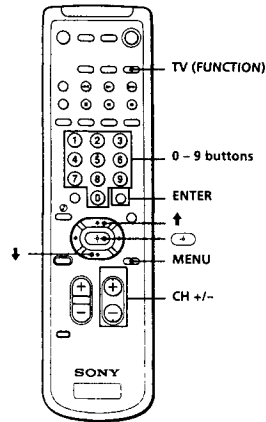

### 1 Press TV (FUNCTION).

--FUNCTION--



### 2 Press MENU.

The main menu appears.



### 3 Press $\uparrow$ or $\downarrow$ to select $\text{TV}$ , and press $\text{ENTER}$ .

The SET UP menu appears.

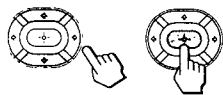

### 4 Press $\uparrow$ or $\downarrow$ to select CHANNEL ERASE/ADD, and press $\text{ENTER}$ .

The CHANNEL ERASE/ADD menu appears.

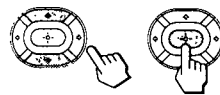

### 5 Erase and/or add channels:

**To erase an unwanted channel**

- (1) Make sure the cursor ( $\blacktriangleright$ ) is beside ERASE.
- (2) Press CH +/- or the 0-9 buttons to select the channel you want to erase, and press ENTER.

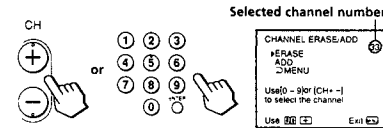

- (3) Press  $\text{ENTER}$ .

The "-" indication appears beside the channel number, showing that the channel is erased from the preset memory.



**To add a channel that you want**

- (1) Press  $\uparrow$  or  $\downarrow$  to move the cursor ( $\blacktriangleright$ ) to ADD.
- (2) Press the 0-9 buttons to select the channel you want to add, and press ENTER.

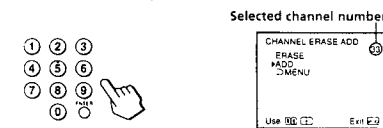

- (3) Press  $\text{ENTER}$ .

The "+" indication appears beside the channel number, showing that the channel is added to the preset memory.



### 6 To erase and/or add other channels, repeat step 5.

### 7 Press MENU to return to the original screen.



#### Notes

- If you erase or add a VHF or UHF channel, the cable TV channel with the same number is also erased or added, and vice versa.
- Erasing and adding channels is also available for the AUX input. (KV-27S35/27V35/29V35C/29V75M/32S35/32V35/34V35C/35V35/35V45/35V75 only)

## Setting cable TV on or off

If you have connected the TV to a cable TV system, set CABLE to ON (the factory setting). If not, set CABLE to OFF. You do not have to do this procedure if you execute AUTO SET UP (page 15). Do this procedure only when you want to set it manually.

### 1 Press MENU.

### 2 Press $\uparrow$ or $\downarrow$ to select $\text{CABLE}$ , and press $\text{ENTER}$ .

### 3 Set CABLE to ON or OFF:

- (1) Press  $\uparrow$  or  $\downarrow$  to move the cursor ( $\blacktriangleright$ ) to CABLE, and press  $\text{ENTER}$ .
- (2) Press  $\uparrow$  or  $\downarrow$  to select ON or OFF, and press  $\text{ENTER}$ .

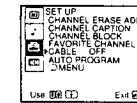
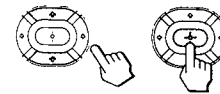

### 4 Press MENU to return to the original screen.

#### Note

- If CABLE appears in gray, the TV is set to a video input and you cannot select CABLE. Press TV (black button) so that a channel number appears

## Presetting channels

You can preset TV channels easily by using the AUTO PROGRAM feature. You do not have to do this procedure if you execute AUTO SET UP (page 15). Do this procedure only when you want to set it manually.

### 1 Press MENU.

### 2 Press $\uparrow$ or $\downarrow$ to select $\text{AUTO PROGRAM}$ , and press $\text{ENTER}$ .

### 3 Press $\uparrow$ or $\downarrow$ to select $\text{AUTO PROGRAM}$ , and press $\text{ENTER}$ .

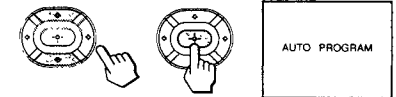

"AUTO PROGRAM" appears on the screen and the TV starts scanning and presetting channels automatically. When all the receivable channels are stored, "AUTO PROGRAM" disappears and the lowest numbered channel is displayed.

### 4 Press MENU to return to the original screen.

#### To exit AUTO PROGRAM

Press any button.

#### Notes

- If the AUTO PROGRAM menu appears in gray, the TV is set to a video input and you cannot select AUTO PROGRAM. Press TV (black) so that a channel number appears.
- Presetting channels is also available for the AUX input. (KV-27S35/27V35/29V35C/29V75M/32S35/32V35/34V35C/35V35/35V45/35V75 only)

## Changing the menu language

### ■ Except Canadian models

If you prefer Spanish to English, you can change the menu language. You do not have to do this procedure if you select the language during AUTO SET UP (page 15).

- 1 Press **MENU**.
- 2 Press **+** or **+** to select **+**, and press **○**.
- 3 Press **+** or **+** to select **LANGUAGE**, and press **○**.

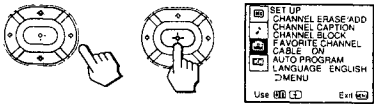

- 4 Press **+** or **+** to select your favorite language, “**ENGLISH**” or “**ESPAÑOL**,” and press **○**.

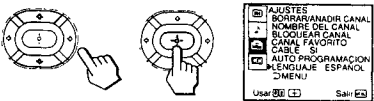

- 5 Press **MENU** to return to the original screen.

**Note**  
• Certain parts of the Spanish menus remain in English.

## Adjusting the tilt of the picture (TILT CORRECTION)

### ■ KV-35V35I35V45I35V75 only

You can adjust the tilt of the picture if it is not aligned with the TV screen. Misalignment may be caused by the direction of the earth's magnetic fields in relation to the position of the TV.

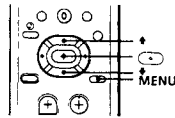

- 1 Press **MENU**.
- 2 Press **+** or **+** to select **+**, and press **○**.
- 3 Press **+** or **+** to select **TILT CORRECTION**, and press **○**.

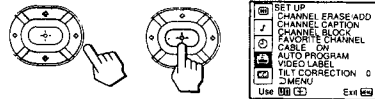

- 4 Press **+** or **+** to adjust the tilt between **+5** and **-5**.
- 5 Press **MENU** to return to the original screen.

**Notes**

- If your house is located near a high-voltage cable or is of reinforced concrete, you may not be able to correct the tilt of the picture properly. Consult your nearest Sony dealer.
- If there are large speakers near the TV, the tilt of the picture cannot be corrected properly. Place the TV away from the speakers.

## Watching the TV

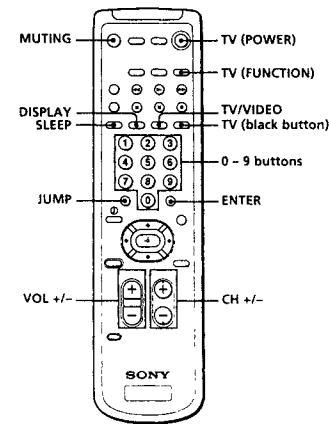

- 1 Press **TV (POWER)** to turn on the TV.



If “**VIDEO**” appears on the screen, press **TV** (black button) so that a channel number appears.

- 2 Press **TV (FUNCTION)**.

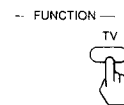

Once you press **TV (FUNCTION)**, the TV function is set unless another function button is pressed.

- 3 Select the channel you want:  
**To select a channel directly**  
Press the 0 - 9 buttons, and press **ENTER**.  
**To scan through channels**  
Press **CH +/-** until the channel you want appears.



The channel can also be selected without pressing **ENTER**.

- 4 Press **VOL +/-** to adjust the volume.

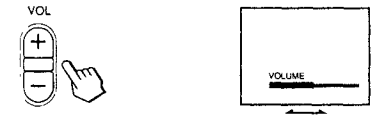

## Switching quickly between two channels

You can use the **JUMP** button to switch or “jump” back and forth between two channels.

Press **JUMP**.



Pressing **JUMP** again switches back the channel.

**Note**  
• You cannot jump to channels you scanned through using the **CH +/-** buttons.

## Muting the sound

Press **MUTING**.  
“**MUTING**” appears on the screen.



To restore the sound, press **MUTING** again, or press **VOL +**.

## Displaying on-screen information

Press **DISPLAY** repeatedly until the desired display appears.

Each time you press **DISPLAY**, the display changes as follows:

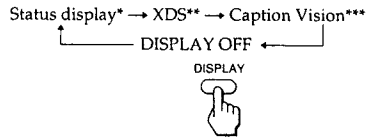

- \* Channel number, the current time (only for available models), channel caption (if set), and MTS mode (if SAP is selected) are displayed. SAP indication disappears after three seconds.
- \*\* Some programs are broadcast with XDS (Extended Data Service) which shows a network name, program name, program type, program length, call letters, and time of the show. When you select XDS with the **DISPLAY** button, this information will be displayed on the screen if the broadcaster offers this service.
- \*\*\* Some programs are broadcast with Caption Vision. When you select Caption Vision with the **DISPLAY** button, Caption Vision will be displayed on the screen if the broadcaster offers this service. (See page 33 for selecting Caption Vision.)

To cancel the display, press **DISPLAY** repeatedly until "DISPLAY OFF" appears. "DISPLAY OFF" goes off after three seconds.

## Setting the Sleep Timer

The TV stays on for the length of time you specify and then shuts off automatically.  
Press **SLEEP** repeatedly until the time (minutes) you want appears.

Each time you press **SLEEP**, the time changes as follows:

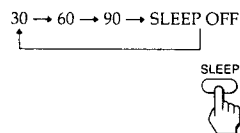

To cancel the Sleep Timer, press **SLEEP** repeatedly until "SLEEP OFF" appears, or turn off the TV.

## Watching a video input picture

Press **TV/VIDEO** repeatedly until the desired video input appears.

Each time you press **TV/VIDEO**, the display changes as follows:

■ **KV-27S25/27S35/29RS25/29RS25C/32S25/32S35/32TW25 only**

TV → VIDEO 1 → VIDEO 2

■ **KV-27V25/27V35/29V35C/29V65M/29V75M/32V25/32V35/34V35C/35V35/35V45/35V75 only**

TV → VIDEO 1 → VIDEO 2 → VIDEO 3

To return to the TV picture, press **TV** (black button) so that a channel number appears.

## Changing the VHF/UHF input to the AUX input

■ **KV-27S35/27V35/29V35C/29V75M/32S35/32V35/34V35C/35V35/35V45/35V75 only**

Press **TV** (black button).



Pressing **TV** (black button) again switches back to the previous input.

## Watching two programs at a time — PIP

The Picture-in-Picture (PIP) feature allows you to watch both the main picture and a window picture simultaneously.

For KV-27S25/27V25/29RS25/29RS25C/29V65M/32S25/32TW25/32V25, your TV must be connected to a VCR to enjoy this feature. See "Connecting an antenna/cable TV system with a VCR" (page 6) for connections. In order to operate PIP, your VCR must be turned on.

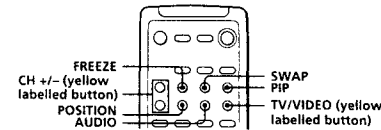

Use the yellow labelled buttons for PIP operations.

## Displaying a window picture

Press **PIP**.

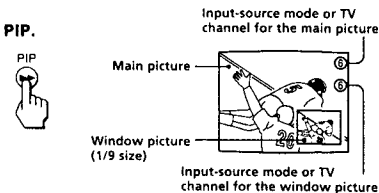

Press **PIP** again to display a smaller window picture.

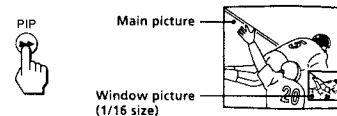

To remove the window picture, press **PIP** again.

### Note

- The window picture may be affected by the condition of the main picture.

## Changing the window picture input mode

Press **TV/VIDEO** (yellow labelled button) to select the input mode.

Each time you press **TV/VIDEO** (yellow labelled button), "TV," "VIDEO 1," "VIDEO 2," and "VIDEO 3" (KV-27V25/27V35/29V35C/29V65M/29V75M/32V25/32V35/34V35C/35V35/35V45/35V75 only) appear in sequence.



A window picture will appear in the same input mode as the last time you used PIP.

### Note

- If you use one of the connections from page 6, your PIP input source is a VCR. If you use one of the connections from page 7, your PIP input source is a VCR or cable box.

## Listening to the sound of the window picture

Press **AUDIO**.

The  $\curvearrowright$  display appears next to the PIP channel number for a few seconds, indicating that the window picture sound is being received.

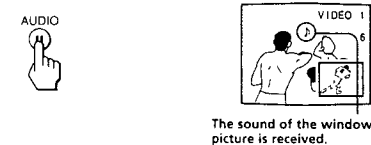

To restore the main picture sound, press **AUDIO** again. The  $\curvearrowright$  display moves to the main picture channel number.

## Changing TV channels in the window picture

Press **CH +/-** (yellow labelled button).



## Changing the position of the window picture

### Press POSITION.

Each time you press POSITION, the window picture will move counterclockwise on the screen.

POSITION

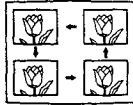

## Freezing the window picture

This feature is useful when you want to write down a recipe from a cooking program, a displayed address, or a phone number for example.

### Press FREEZE.

FREEZE



To restore the normal screen, press FREEZE again.

## Swapping the main and window pictures

### Press SWAP.

Each time you press SWAP, the images from the main and window pictures switch places along with the sound.

SWAP

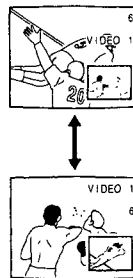

### Note

- The channels being received through the AUX jack cannot be displayed as a window picture. (KV-27S35/27V35/29V35C/29V75M/32S35/32V35/34V35C/35V35/35V45/35V75 only)

## Adjusting the picture (VIDEO)

When watching TV programs, you can adjust the picture to suit your taste. You can adjust the picture of video input(s) as well. These settings are stored separately from those for the TV picture.

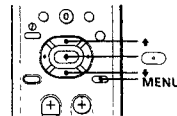

### 1 Press MENU.

### 2 Press + or + to select **VIDEO MODE**, and press **ENTER**.

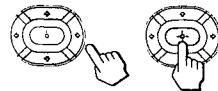

### 3 Select the item you want to adjust. For example:

(1) To adjust the brightness, press + or + to move the cursor (▶) to BRIGHTNESS.

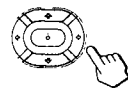

(2) Press **ENTER**.



### 4 Adjust the selected item:

(1) Press + or + to adjust the item.

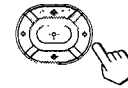

(2) Press **ENTER**.

The new setting appears in the VIDEO menu.



For details on each item, see "Description of adjustable items" below.

### 5 To adjust other items, repeat steps 3 and 4.

### 6 Press MENU to return to the original screen.

#### Description of adjustable items

Item	Press + to	Press + to
PICTURE	Decrease picture contrast and give soft color.	Increase picture contrast and give vivid color
HUE	Make picture tones become purplish.	Make picture tones become greenish
COLOR	Decrease color intensity.	Increase color intensity
BRIGHTNESS	Darken the picture.	Brighten the picture
SHARPNESS	Soften the picture.	Sharpen the picture.

#### To restore the factory settings

Press RESET while the VIDEO menu is displayed. All the settings are restored to the factory settings.

## Selecting the video mode (VIDEO)

The video mode feature allows you to choose three different modes of picture settings. Choose the one that best suits the type of program that you want to watch.

### 1 Press MENU.

### 2 Press + or + to select **VIDEO MODE**, and press **ENTER**.

### 3 Press + or + to select **MODE**, and press **ENTER**.

### 4 Press + or + to select **STANDARD**, **MOVIE**, or **SPORTS** mode, and press **ENTER**.

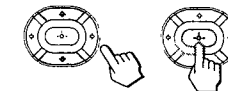

Choose	To
STANDARD	Receive a standard picture.
MOVIE	Receive a finely detailed picture.
SPORTS	Receive a vivid, bright picture.

### 5 Press MENU to return to the original screen.

#### Note

- The settings for these modes can be adjusted in the VIDEO menu.

## Adjusting picture brightness automatically (LIGHTSENSOR)

■ KV-27V25I/27V35I/29V35CI/29V65MI/29V75MI/32V25I/32V35I/34V35CI/35V35I/35V45I/35V75 only

The LightSensor feature adjusts the brightness of the picture automatically according to the ambient brightness.

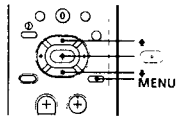

- 1 Press MENU.
- 2 Press  $\uparrow$  or  $\downarrow$  to select  $\square$ , and press  $\rightarrow$ .
- 3 Press  $\uparrow$  or  $\downarrow$  to select LIGHTSENSOR, and press  $\rightarrow$ .

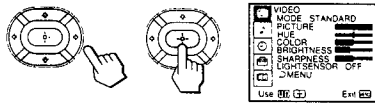

- 4 Press  $\uparrow$  or  $\downarrow$  to select ON or OFF, and press  $\rightarrow$ .

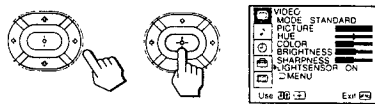

- 5 Press MENU to return to the original screen.

### Note

- The LightSensor function may malfunction if you stand or place objects in front of the TV.

## Adjusting the sound (AUDIO)

You can adjust the TV sound to suit your taste. You can adjust the sound of the video input(s) as well. These settings are stored separately from those for the TV sound.

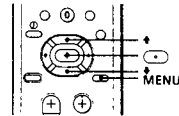

- 1 Press MENU.
- 2 Press  $\uparrow$  or  $\downarrow$  to select  $\square$ , and press  $\rightarrow$ .

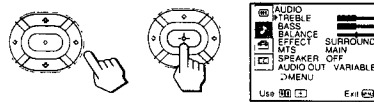

- 3 Select the item you want to adjust.

### For example:

- (1) To adjust bass, press  $\uparrow$  or  $\downarrow$  to move the cursor  $\blacktriangleright$  to BASS.



- (2) Press  $\rightarrow$ .



- 4 Adjust the selected item:

(1) Press  $\uparrow$  or  $\downarrow$  to adjust the item.



- (2) Press  $\rightarrow$ .

The new setting appears in the AUDIO menu.

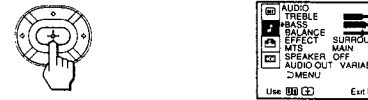

For details on each item, see "Description of adjustable items" below.

- 5 To adjust other items, repeat steps 3 and 4.

- 6 Press MENU to return to the original screen.

### Description of adjustable items

Item	Press $\uparrow$ to	Press $\downarrow$ to
TREBLE	Decrease the treble response.	Increase the treble response.
BASS	Decrease the bass response.	Increase the bass response.
BALANCE	Emphasize the left speaker's volume.	Emphasize the right speaker's volume.

### To restore the factory settings

Press RESET while the AUDIO menu is displayed.

### Note

- When SPEAKER (page 27) is OFF and AUDIO OUT (page 27) is in the FIXED condition, the volume, TREBLE, BASS, and BALANCE cannot be adjusted.

## Using audio effect (EFFECT)

### Using the $\square$ (audio effect) button

■ For KV-27V25I/27V35I/29V35CI/29V65MI/29V75MI/32V25I/32V35I/34V35CI/35V35I/35V45I/35V75 only

### Press $\square$ .

Each time you press the  $\square$  button, the display changes as follows:

SURROUND  $\rightarrow$  SURROUND OFF



■ For KV-27V25I/27V35I/29V35CI/29V65MI/29V75MI/32V25I/32V35I/34V35CI/35V35I/35V45I/35V75 only

### Press $\square$ .

Each time you press the  $\square$  button, the display changes as follows:

SRS  $\rightarrow$  SIMULATED  $\rightarrow$  EFFECT OFF



Choose	To
SURROUND	Simulate sound reproduction with the atmosphere of a movie theater or a concert hall. Surround sound is only effective for stereo programs.
SRS	When the program's audio signal is stereo or encoded, SRS expands the material and embraces you with dynamic three-dimensional sound.
SIMULATED	Receive monaural sound with a surround-like effect.

### Note

- To use the  $\square$  button function, press TV (FUNCTION).

## Using the menu to set audio effect

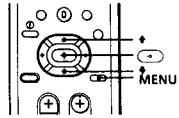

- 1 Press **MENU**.
- 2 Press **+** or **+** to select **↓**, and press **○**.
- 3 Press **+** or **+** to select **EFFECT**, and press **○**.

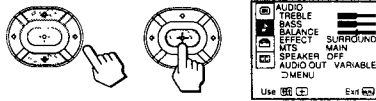

- 4 Press **+** or **+** to select the audio effect mode, and press **○**.

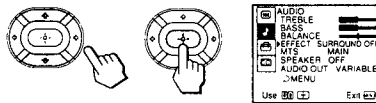

- 5 Press **MENU** to return to the original screen.

## Selecting stereo or bilingual programs (MTS)

The Multichannel TV Sound (MTS) feature allows you to enjoy stereo sound or Second Audio Programs (SAP) of your choice. The initial setting is stereo sound (MAIN).

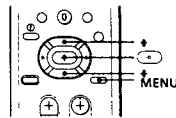

- 1 Press **MENU**.
- 2 Press **+** or **+** to select **↓**, and press **○**.
- 3 Press **+** or **+** to select **MTS**, and press **○**.

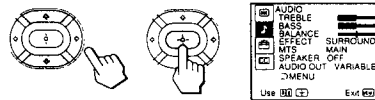

- 4 Press **+** or **+** to select **MAIN**, **SAP**, or **MONO**, and press **○**.

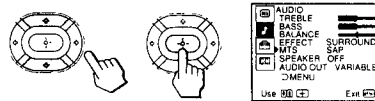

Choose	To
MAIN	Listen to stereo sound. The STEREO indicator on the TV lights up when a stereo broadcast is received.
SAP	Listen to bilingual programs. There is no sound when the SAP signal is not broadcasting.
MONO	Listen to monaural sound. Reduce noise during stereo broadcasts.

- 5 Press **MENU** to return to the original screen.

### Note

- Stereo and SAP sounds are subject to program sources.

## Setting the speaker switch (SPEAKER)

You may switch off the TV speakers when, for example, you want to listen to the sound through a stereo system.

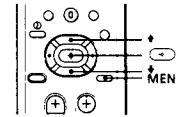

- 1 Press **MENU**.
- 2 Press **+** or **+** to select **↓**, and press **○**.
- 3 Press **+** or **+** to select **SPEAKER**, and press **○**.

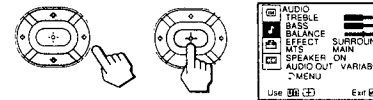

- 4 Press **+** or **+** to select **ON** or **OFF**, and press **○**.

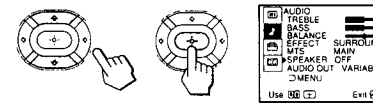

- 5 Press **MENU** to return to the original screen.

## Setting audio out (AUDIO OUT)

You can change AUDIO OUT to VARIABLE or FIXED when SPEAKER is set to OFF. AUDIO OUT is variable when SPEAKER is set to ON.

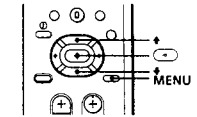

- 1 Press **MENU**.
- 2 Press **+** or **+** to select **↓**, and press **○**.
- 3 Press **+** or **+** to select **AUDIO OUT**, and press **○**.

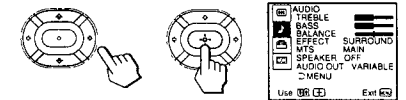

- 4 Press **+** or **+** to select **VARIABLE** or **FIXED**, and press **○**.

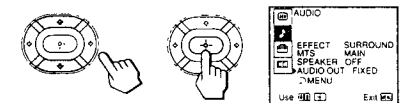

**VARIABLE:** Sound output varied according to the TV settings. You can adjust the volume, bass, treble, and balance.

**FIXED:** Sound output is always fixed to a certain level. The volume, bass, treble, and balance are also fixed to the factory settings.

- 5 Press **MENU** to return to the original screen.

### Note

- If AUDIO OUT appears in gray, set SPEAKER to OFF

## Setting daylight saving time (DAYLIGHT SAVING)

■ KV-27V25I27V35I29V35CI29V65MI29V75MI32V25I32V35I34V35CI35V35I35V45I35V75 only

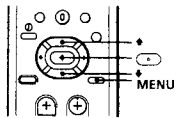

- 1 Press MENU.
- 2 Press  $\uparrow$  or  $\downarrow$  to select  $\odot$ , and press  $\rightarrow$ .
- 3 Press  $\uparrow$  or  $\downarrow$  to select DAYLIGHT SAVING, and press  $\rightarrow$ .

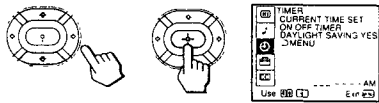

- 4 Press  $\uparrow$  or  $\downarrow$  to select YES or NO, and press  $\rightarrow$ .

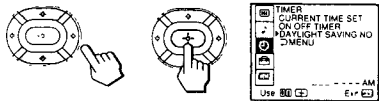

Choose	To
YES	Set for daylight saving start. The current time automatically moves one hour ahead.
NO	Set for daylight saving end.

- 5 Press MENU to return to the original screen.

## Setting the clock (CURRENT TIME SET)

■ KV-27V25I27V35I29V35CI29V65MI29V75MI32V25I32V35I34V35CI35V35I35V45I35V75 only

Setting the clock enables you to turn the TV on and off with the timer. Make sure to set daylight saving time first.

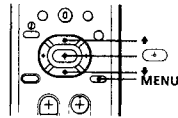

- 1 Press MENU.
- 2 Press  $\uparrow$  or  $\downarrow$  to select  $\odot$ , and press  $\rightarrow$ .
- 3 Press  $\uparrow$  or  $\downarrow$  to select CURRENT TIME SET, and press  $\rightarrow$ .



- 4 Make sure the cursor ( $\blacktriangleright$ ) is to the left of "--:-- AM," and press  $\rightarrow$ .



- 5 Set the current time.

- (1) Press  $\uparrow$  or  $\downarrow$  to set the day, and press  $\rightarrow$ .

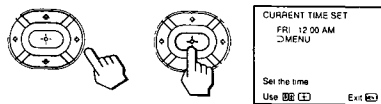

- (2) Set the hour and minutes in the same way as in step (1). When you press  $\rightarrow$  after setting the minutes, the clock starts.

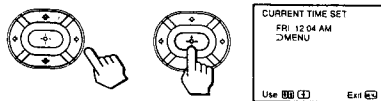

- 6 Press MENU to return to the original screen.

## Setting the timer to turn the TV on and off (ON/OFF TIMER)

■ KV-27V25I27V35I29V35CI29V65MI29V75MI32V25I32V35I34V35CI35V35I35V45I35V75 only

You can set the TV to turn on and off at the times you specify. Make sure the clock is set correctly. If it is not, set the clock first (page 28).

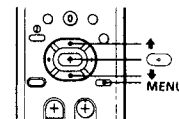

- 1 Press MENU.
- 2 Press  $\uparrow$  or  $\downarrow$  to select  $\odot$ , and press  $\rightarrow$ .
- 3 Press  $\uparrow$  or  $\downarrow$  to select ON/OFF TIMER, and press  $\rightarrow$ .

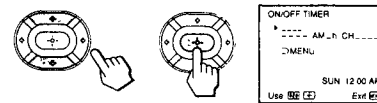

- 4 Press  $\rightarrow$  and enter the ON/OFF TIMER setting.

- (1) Press  $\uparrow$  or  $\downarrow$  to set the day(s), and press  $\rightarrow$ .

Each time you press  $\uparrow$  or  $\downarrow$ , the days cycle as follows:  
 EVERY SUN-SAT → EVERY MON-FRI →  
 SUNDAY → ... → SATURDAY → EVERY  
 SUNDAY → ... → EVERY SATURDAY

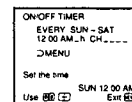
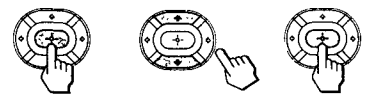

- (2) Press  $\uparrow$  or  $\downarrow$  to set the time (hour then minutes) that you want to turn on the TV, and press  $\rightarrow$ .

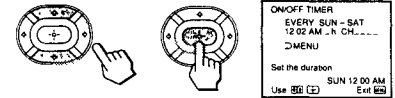

- (3) Press  $\uparrow$  or  $\downarrow$  to set the time duration, and press  $\rightarrow$ .

Each time you press  $\uparrow$ , the time duration increases by one hour up to a maximum of six hours.

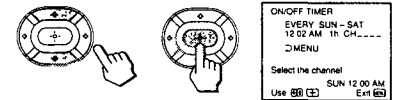

- (4) Press  $\uparrow$  or  $\downarrow$  to select the channel, and press  $\rightarrow$ .

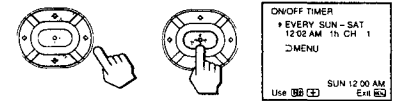

The TIMER indicator on the TV lights up.

- 5 Press MENU to return to the original screen.

One minute before the TV turns off, the message "TV will be off soon." is displayed on the screen.

### To cancel the timer

In step 3 or 4, press RESET.

### Note

- If you unplug the TV or a power interruption occurs, the ON/OFF TIMER setting will be erased. Reset the current time, then set the timer.

## Customizing the channel names (CHANNEL CAPTION)

You can add a caption for up to 12 channels. This feature allows you to easily identify which channel you are watching. You can make your own caption.

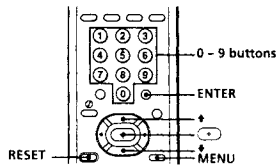

**1** Press MENU.

**2** Press + or + to select , and press .

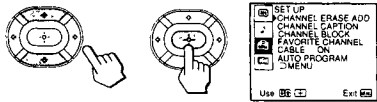

**3** Press + or + to select CHANNEL CAPTION, and press .

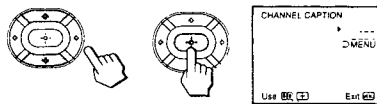

**4** Press and press + or + to select the channel that you want to caption, and press .

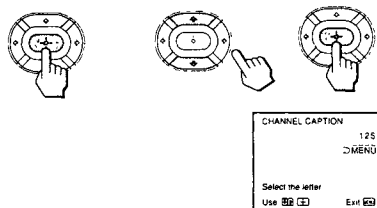

**5** Enter the letters (up to four) to caption the channel:

(1) Press + or + to select the first letter.

Each time you press + or +, the letter changes as follows:

0 → 1 → ... → 9 → A → B → ... → Z → & → \* → / → (blank space)

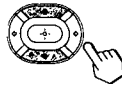

(2) Press .

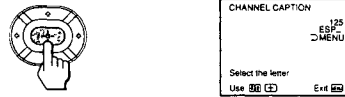

(3) Repeat steps (1) and (2) to select the remaining letters, and press .

**6** To caption other channels, repeat steps 4 and 5.

**7** Press MENU to return to the original screen.

After you customize the channel, the channel caption appears green.

**To erase a caption**  
In step 5, press RESET.

### Notes

- If the CHANNEL CAPTION menu appears in gray, the TV is set to a video input, and you cannot select CHANNEL CAPTION. Press TV (black button) so that a channel number appears.
- If more than 90 seconds elapse after you press a button, the menu disappears automatically.
- The channel caption feature is not available for the AUX input.

## Blocking out a channel (CHANNEL BLOCK)

The channel block feature allows you to prevent children from watching unsuitable programs. You can block out two channels.

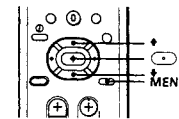

**1** Press MENU.

**2** Press + or + to select , and press .

**3** Press + or + to select CHANNEL BLOCK, and press .

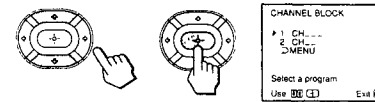

**4** Press + or + to select 1 or 2, and press .

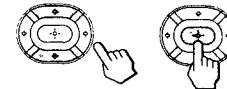

**5** Press + or + to select the channel which you want to block out, and press .

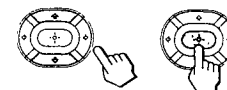

**6** Press MENU to return to the original screen.

When you select the blocked channel "BLOCKED" appears on the screen.

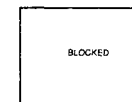

**To cancel a CHANNEL BLOCK setting**

In step 4 or 5, press RESET.

### Note

- Once you use CHANNEL BLOCK, Caption Vision and XDS of the blocked channel and the selected channel output from TV OUT/MONITOR OUT are also blocked out.

## Setting your favorite channels (FAVORITE CHANNEL)

The favorite channel feature allows your TV to memorize your favorite channels easily. If you set to AUTO, the last five channels you selected with the 0 – 9 buttons are automatically set as your favorite channels. If you want to input your own selection of channels, set to MANUAL.

### Setting your favorite channels

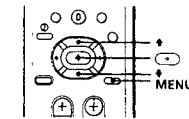

**1** Press MENU.

**2** Press + or + to select , and press .

**3** Press + or + to select FAVORITE CHANNEL, and press .

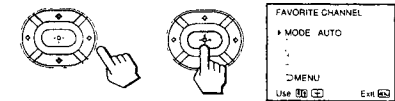

**4** Press and press + or + to select AUTO or MANUAL, and press .

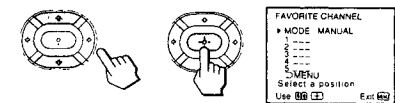

If you select AUTO, skip steps 5 and 6.

The last five channels you selected with the 0 – 9 buttons are automatically set as your favorite channels.

If you select MANUAL, the favorite channel numbers become white, indicating that favorite channels can be entered.

(continued)

- 5** Press **+** or **+** to select a favorite channel number, and press **OK**.

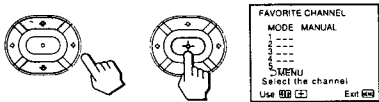

- 6** Press **+** or **+** to select the channel that you want to set as your favorite channel, and press **OK**.

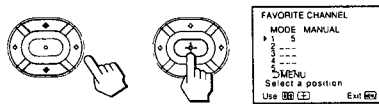

- 7** Press **MENU** to return to the original screen.

**Notes**

- If the FAVORITE CHANNEL menu appears in gray, the TV is set to a video input and you cannot select FAVORITE CHANNEL.
- If more than 90 seconds elapse after you press another button, the menu disappears automatically.
- The favorite channel feature is not available for the AUX input.

**Selecting your favorite channel**

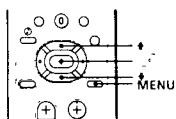

- 1** Press **MENU**.  
The FAVORITE CHANNEL menu appears.



- 2** Press **+** or **+** to select the favorite channel you want to watch, and press **OK**.  
The selected channel appears on the screen.

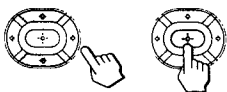

- To cancel the FAVORITE CHANNEL menu**  
Press **+** or **+** to select "Exit," and press **OK**.

**Setting video labels  
(VIDEO LABEL)**

■ KV-27V25I/27V35I/29V35C/29V65M/29V75M/32V25I/32V35I/34V35C/35V35I/35V45I/35V75 only

The video label feature allows you to label each input mode so that you can easily identify the connected equipment. For example, you can label VIDEO 1 IN as VHS.

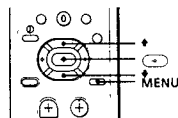

- 1** Press **MENU**.
- 2** Press **+** or **+** to select **VIDEO LABEL**, and press **OK**.
- 3** Press **+** or **+** to select **VIDEO LABEL**, and press **OK**.

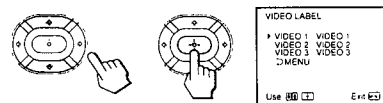

- 4** Press **+** or **+** to select the input mode you want to label, and press **OK**.

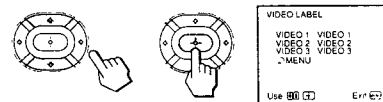

- 5** Press **+** or **+** to select the label, and press **OK**.

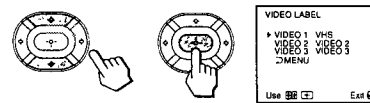

Each time you press **+** or **+**, the label changes as follows:

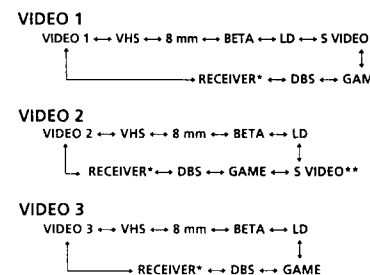

\* KV-27V35I/29V35C/29V75M/32V35I/34V35C/35V45I/35V75 only

\*\* KV-32V35I/34V35C/35V45I/35V75 only  
When you connect an AV receiver to the TV using the AV receiver's TV input jacks, it is recommended to set the label to RECEIVER. When RECEIVER is selected, TV channels can be selected while the video input mode is fixed. (See page 11 for the connection.)

- 6** Repeat steps 4 and 5 to label other input modes.

**Note**

- If more than 90 seconds elapse before you press another button, the menu disappears automatically.

**Setting Caption Vision (CAPTION VISION)**

Some programs are broadcast with Caption Vision. To display Caption Vision, select either CC1, CC2, CC3, CC4, TEXT1, TEXT2, TEXT3, or TEXT4 from the menu. CC1, CC2, CC3, or CC4 shows you a caption, that is a printed version of the dialogue or sound effects of a program. (The mode should be set to CC1 for most programs.) TEXT1, TEXT2, TEXT3, or TEXT4 shows you text, that is information presented using either half or the whole screen. It is not usually related to the program.

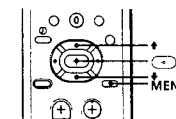

- 1** Press **MENU**.
- 2** Press **+** or **+** to select **CAPTION VISION**, and press **OK**.

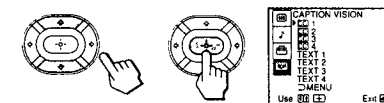

- 3** Press **+** or **+** to select the caption type, and press **OK**.

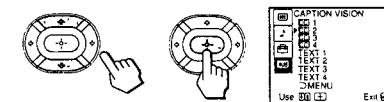

- 4** Press **MENU** to return to the original screen.

**To display Caption Vision**  
Press **DISPLAY**. (See page 20 for details.)

**Notes**

- Poor reception of TV programs can cause errors in Caption Vision and XDS.
- Captions may appear with a white box or other errors instead of a certain word.
- XDS, Caption Vision, and the status display cannot be used at the same time.
- For details on XDS, see page 20.

# Operating video equipment

You can use the supplied remote commander to operate Sony or non-Sony video equipment that has an infrared remote sensor. For this operation, set the manufacturer's code number.

## Setting the manufacturer's code

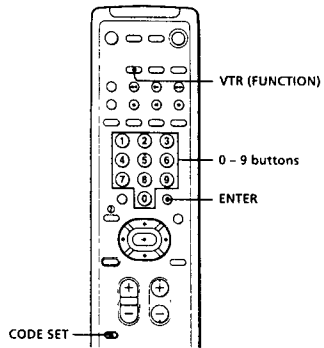

Press the **CODE SET**, **VTR (FUNCTION)**, and **0 - 9** buttons to enter the manufacturer's code number (see the chart), then press **ENTER**. For example, to operate a Sony 8 mm VCR, press **CODE SET**, **VTR (FUNCTION)**, **3**, **0**, **2**, and **ENTER**.



## VCR manufacturer code numbers

Manufacturer	Code number
Sony	301, 302, 303
Aiwa	338
Audio Dynamic	314, 337
Bell & Howell (M. Wards)	330, 343
Brocsonic	319
Canon	309, 308
Citizen	332
Craig	315, 302, 332
Curtis Mathis	304, 338, 309
Daewoo	341, 312, 309
DBX	314, 336, 337
Dimensia	304
Emerson	319, 320, 316, 317, 318
Fisher	330, 334, 335, 333
Funai	338
General Electric	329, 304, 309
Goldstar	332
Hitachi	306, 304, 305
Instant Replay	309, 308
JC Penny	309, 305, 304, 330, 314, 336, 337
JVC	314, 336, 337
Kenwood	314, 336, 332, 337
LXI (Sears)	332, 305, 333, 334, 330, 335
Magnavox	308, 309
Marantz	314, 336, 337
Marta	332
Memorex	309, 335
Minolta	305, 304
Mitsubishi/MGA	323, 324, 325, 326
Multitech	325, 338, 321
NEC	314, 336, 337
Olympic	309, 308
Panasonic	308, 309, 306, 307
Pentax	305, 304
Philco	308, 309
Philips	308, 309
Pioneer	308
Quasar	308, 309
RCA/PROSCAN	304, 305, 308, 309, 311, 312, 313
Realistic	309, 330, 328, 335, 324, 338
Sansui	314
Singer	315
Samsung	322, 313, 321
Sanyo	330, 335
Scott	312, 313, 321, 335, 323, 324, 325, 326
Sharp	327, 328
Shintom	315
Signature 2000 (M. Wards)	338, 327
Sylvania	308, 309, 338
Symphonic	338
Tashiro	332
Tatung	314, 336, 337
Teac	314, 336, 338, 337
Technics	309, 308
Toshiba	312, 311
Wards	327, 328, 335, 331, 332
Yamaha	330, 314, 336, 337
Zenith	331

## Notes

- If more than one code number is listed, try entering them one by one, until you come to the correct code for your equipment.
- In some rare cases, you may not be able to operate your non-Sony video equipment with the supplied remote commander. This is because your equipment may use a code that is not included with this remote commander. In this case, please use the equipment's own remote control unit.
- The code numbers for Sony equipment are assigned at the factory as follows.  
VHS VCR 301 (preset code for the supplied remote commander)  
8 mm VCR 302  
Beta, ED Beta VCRs 303
- Whenever you remove the batteries — to replace them, for example — if too much time is taken, the code number may revert to the factory setting and must be reset.

## Operating video equipment

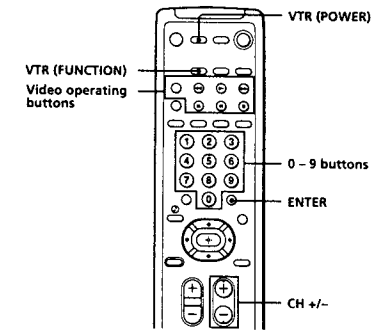

Use the video operating buttons on the remote commander to operate the video equipment. Press **VTR (FUNCTION)** before operating the video equipment.

Operating a VCR	Buttons on the remote commander
To turn on or off	Press <b>VTR (POWER)</b> .
To select a channel directly	Press the <b>0 - 9</b> buttons.
To change channels	Press <b>CH +/-</b> .
To record	Press <b>▶</b> while pressing <b>●</b> . First release <b>▶</b> , then release <b>●</b> .
To play	Press <b>▶</b> .
To stop	Press <b>■</b> .
To fast forward	Press <b>▶▶</b> .
To rewind the tape	Press <b>◀◀</b> .
To pause	Press <b>  </b> .
To search the picture forward or backward	Press <b>▶▶</b> or <b>◀◀</b> during playback. To resume normal playback, release the button.
To change input mode	Press <b>TV/VTR</b> .

## Note

- If the video equipment does not have a certain function, the corresponding button on this remote commander will not operate.

## Turning off the system

■ **KV-27V25/27V35/29V35C/29V65M/29V75M/32V25/32V35/34V35C/35V35/35V45/35V75 only**

You can turn off the TV and Sony equipment with the S-Link function, such as a VCR, together when you make the S-Link connection (see page 10 for the connection).

Press **SYSTEM OFF**.



## Operating a cable box or DBS receiver

You can program the supplied remote commander to operate a cable box or DBS receiver. Follow the procedures below to set the manufacturer's code number in the remote commander.

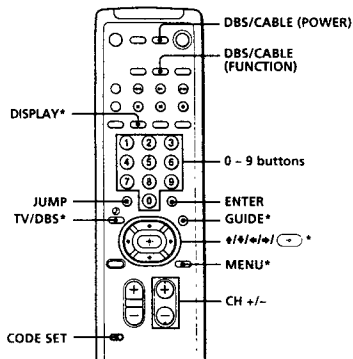

\* The TV/DBS, GUIDE, DISPLAY,  $\blacktriangle/\blacklozenge/\blacktriangleright/\blacktriangleleft$ , and MENU buttons can be used only with a DBS receiver.

### 1 Turn off the equipment you want to set up, and press DBS/CABLE (FUNCTION).

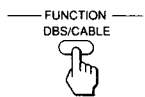

### 2 Press the CODE SET, DBS/CABLE (FUNCTION), and 0-9 buttons to enter the manufacturer's code number (see the chart), then press ENTER. For example, to program your remote commander to operate a Sony DBS receiver, press CODE SET, DBS/CABLE (FUNCTION), 8, 0, 1, and ENTER.

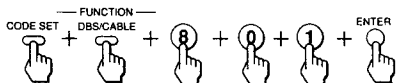

### 3 Press DBS/CABLE (POWER) to turn on the cable box or DBS receiver.

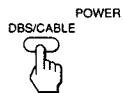

### 4 Use the cable box/DBS control buttons to check if the code number works.

For example, to operate a cable box or DBS receiver, you can use the DBS/CABLE (POWER), JUMP, CH +/-, 0-9 and ENTER buttons.

#### Note

- If the cable box or DBS receiver does not have a certain function, the corresponding button on this remote commander will not operate.

#### To operate the TV

Press TV (FUNCTION). Then use the TV control buttons to control the TV.

#### For more details on operating the cable box or DBS receiver

Refer to the operating instructions that come with the equipment.

#### If the remote commander doesn't work

- First, try repeating the setup procedures using the other codes listed for your equipment.

#### Manufacturer code numbers (cable box)

Manufacturer	Code number
Hamlin/Regal	222, 223, 224, 225, 226
Jerrold/G. I.	201, 202, 203, 204, 205, 206, 207, 208, 218
Oak	227, 228, 229
Panasonic	219, 220, 221
Pioneer	214, 215
Scientific Atlanta	210, 211
Tocom	216, 217
Zenith	212, 213

#### Manufacturer code numbers (DBS receiver)

Manufacturer	Code number
Sony	801 (preset code for the supplied remote commander)

#### Notes

- If more than one code number is listed, try entering them one by one until you come to the correct code for your equipment.
- If you enter a new code number, the code number you previously entered at that setting is erased.
- In some rare cases, your equipment may use a code that is not provided with this remote commander and you may not be able to operate your equipment with the supplied remote commander. In this case, use the equipment's own remote control unit.
- Whenever you remove the batteries — to replace them, for example — if too much time is taken, the code numbers may revert to the factory setting and must be reset.

## Troubleshooting

If the problem persists after trying the methods below, contact your nearest Sony dealer.

#### No picture (screen not lit), no sound

- Make sure the power cord is connected securely.
- Operate with the buttons on the TV.
- Insert the batteries in the remote commander with the correct polarity.
- Replace the batteries with new ones if they are weak.
- Check to see if the TV/VIDEO setting is correct: when watching TV, set to TV, and when watching video tapes, set to VIDEO1, 2 or 3.
- Try another channel. It could be station trouble.
- Perform AUTO SET UP again using the SET UP button to return to the factory preset condition. (page 15)

#### Poor or no picture (screen lit), good sound

- Adjust PICTURE in the VIDEO menu. (page 22)
- Adjust BRIGHTNESS in the VIDEO menu. (page 22)
- Check antenna/cable connections.
- Perform AUTO SET UP again using the SET UP button to return to the factory preset condition. (page 15)
- Remove objects from the front of TV.
- Check the LIGHTSENSOR setting in the VIDEO menu. (page 24)

#### Good picture, no sound

- Press MUTING so that "MUTING" disappears from the screen. (page 19)
- Check the MTS setting in the AUDIO menu (page 26)
- Make sure SPEAKER is set to ON in the AUDIO menu. (page 27)
- Perform AUTO SET UP again using the SET UP button to return to the factory preset condition (page 15)

#### No color

- Adjust the COLOR in the VIDEO menu. (page 22)
- Black and white programs cannot be seen in color.
- Perform AUTO SET UP again using the SET UP button to return to the factory preset condition. (page 15)

#### Only snow and noise appear on the screen

- Check the CABLE setting in the SET UP menu. (page 17)
- Check the antenna/cable connections.
- Make sure the channel is broadcasting programs.
- Press TV (black button) to change the input mode. (page 20)

#### Dotted lines or stripes

- Adjust the antenna.
- Move the TV away from noise sources such as cars, neon signs, and hair-dryers.

#### Double images or ghosts

- Use a highly directional outdoor antenna or a cable (when the problem is caused by reflections from nearby mountains or tall buildings).

#### Cannot operate menu

- If the item you want to choose appears in gray, you cannot select it. Press TV/VIDEO correctly.

#### Cannot receive upper channels (UHF) when using an antenna

- Make sure CABLE is OFF in the SET UP menu. (page 17)
- Use AUTO PROGRAM to add receivable channels that are not presently in TV memory. (pages 15, 17)

#### Cannot receive any channels when using cable TV

- Make sure CABLE is ON in the SET UP menu. (page 17)
- Use AUTO PROGRAM to add receivable channels that are not presently in TV memory. (pages 15, 17)

#### Remote commander does not operate

- Batteries could be weak. Replace the batteries.
- Make sure the TV's power cord is connected securely to the wall outlet.
- Press TV (FUNCTION) when operating your TV.
- Are fluorescent lights too close to the TV? Move them at least 3-4 feet away from the TV.
- Check the S-Link connection. (page 10)

#### Cannot gain enough volume when using a cable box

- Increase the volume at the cable box. Then press TV (FUNCTION) and adjust the TV's volume.

#### TV malfunctions when using the S-Link function

- (KV-27V25/27V35/29V35C/29V65M/29V75M/32V25/32V35/34V35C/35V35/35V45/35V75 only)
- Make sure the TV's power cord is connected securely to the wall outlet.
- Check the S-Link connection. (page 10)

#### The TV needs to be cleaned

- Clean the TV with a soft dry cloth. Never use strong solvents such as thinner or benzine, which might damage the finish of the cabinet.

## SECTION 2 DISASSEMBLY

### 2-1. REAR COVER REMOVAL

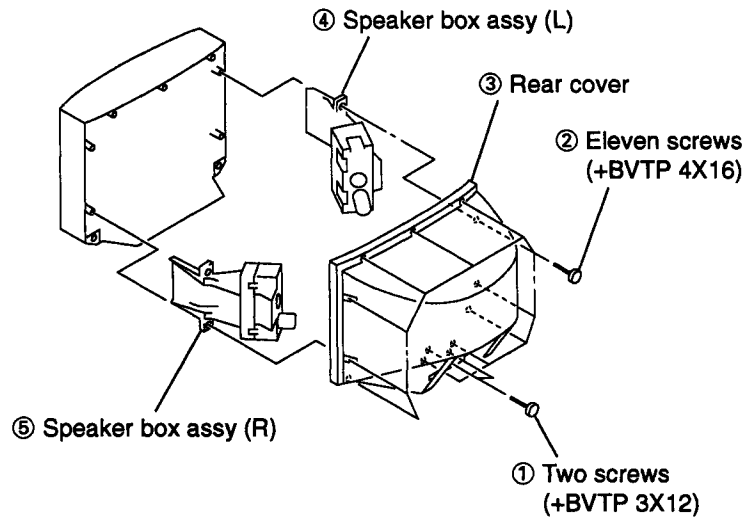

### 2-3. SERVICE POSITION

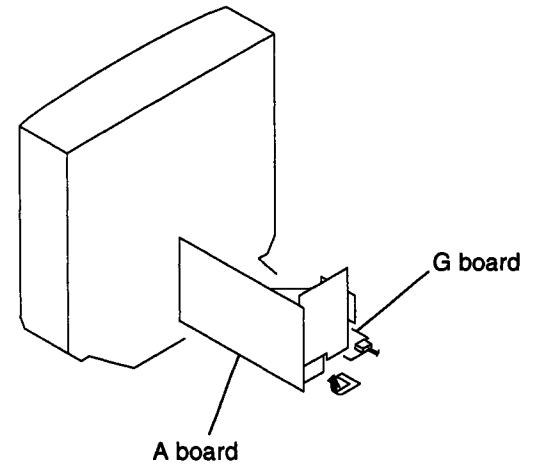

### 2-2. CHASSIS ASSY REMOVAL

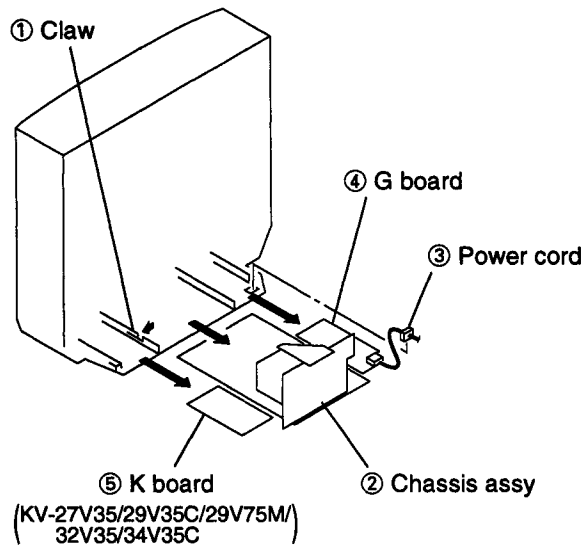

### 2-4. CONTROL SWITCH REMOVAL (KV-27V35/29V35C/29V75M/32V35/34V35C)

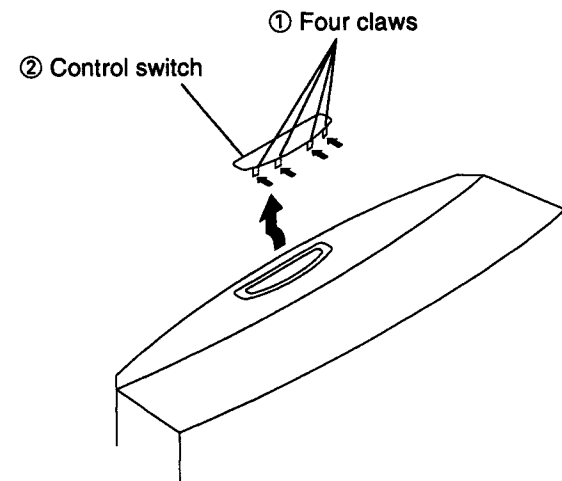

## 2-5. PICTURE TUBE REMOVAL

(KV-27V20/27V25/27V35/29V20M/29V35C/29V65M/29V75M)

**WARNING** : Before removing anode cap H.V. remains in the CRT even after the power is disconnected.

To avoid electrical shock before attempting to remove the anode cap, discharge CRT: Short between anode and CRT coated earth ground strap.

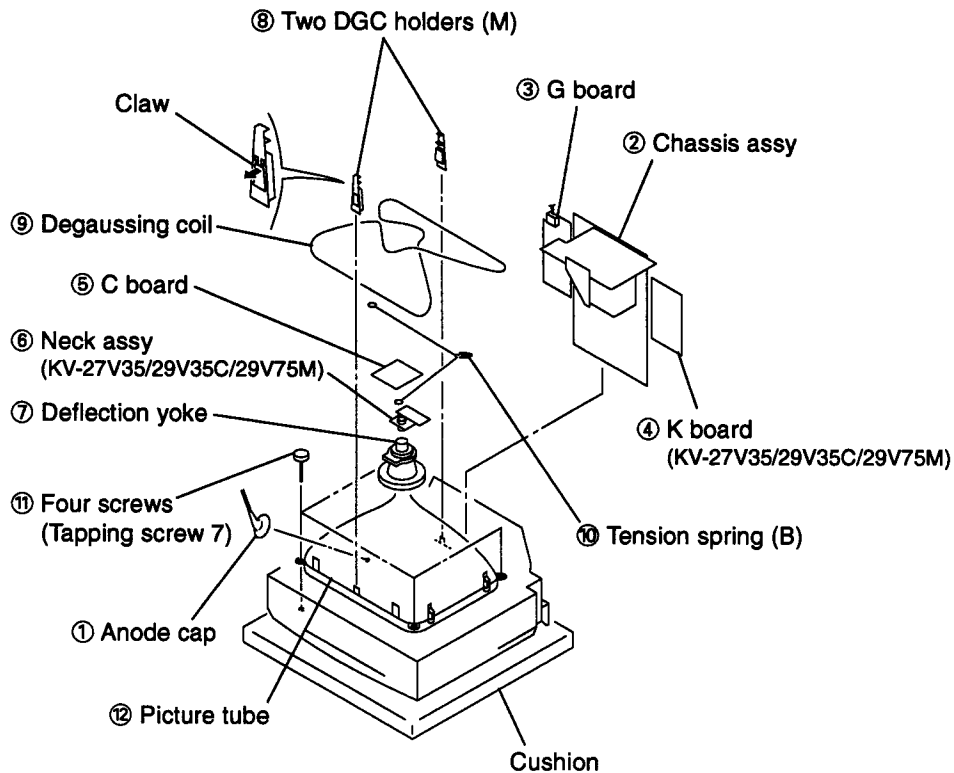
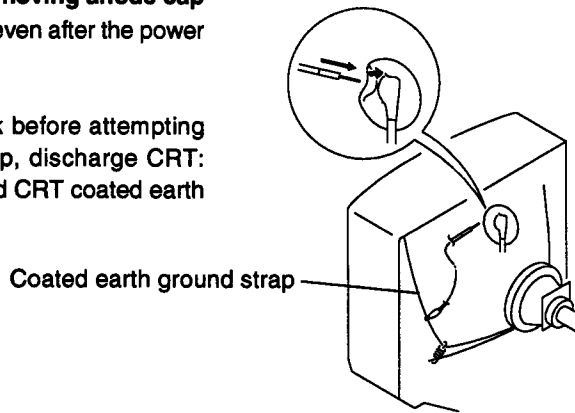

## 2-6. PICTURE TUBE REMOVAL

(KV-32V25/32V35/34V35C)

**WARNING** : Before removing anode cap H.V. remains in the CRT even after the power is disconnected.

To avoid electrical shock before attempting to remove the anode cap, discharge CRT: Short between anode and CRT coated earth ground strap.

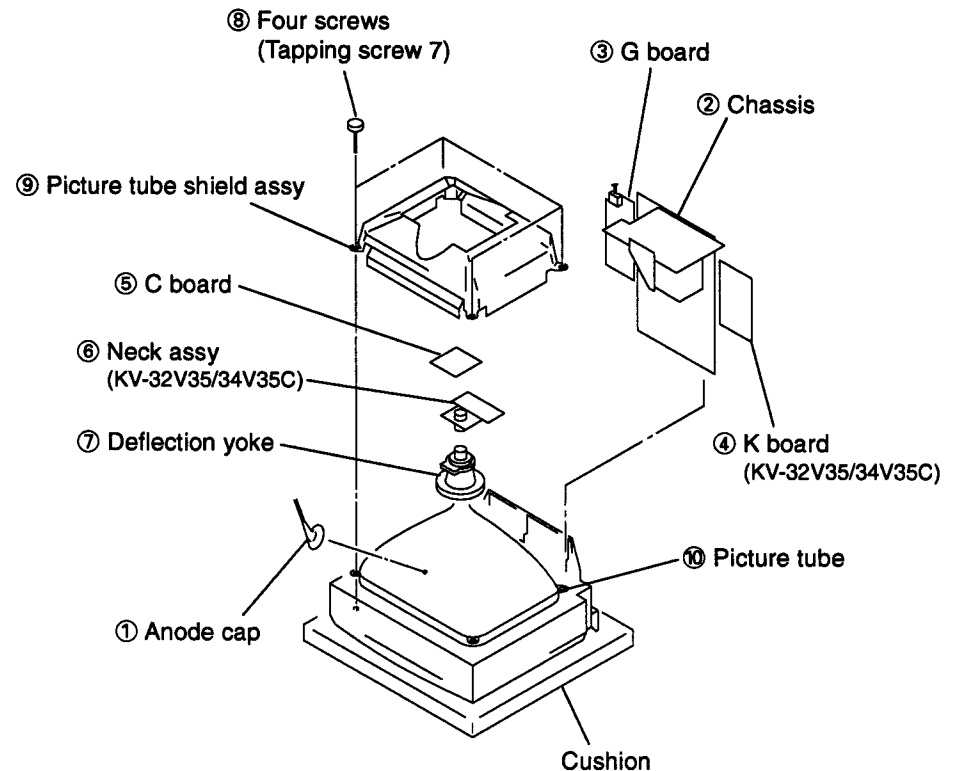
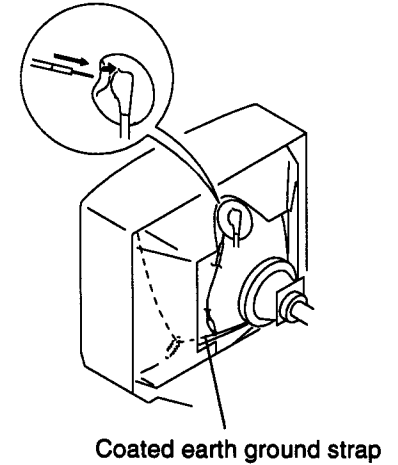

## • REMOVAL OF ANODE-CAP

NOTE : Short circuit the anode of the picture tube and the anode cap to the metal chassis, CRT shield or carbon paint on the CRT, after removing the anode.

### • REMOVING PROCEDURES

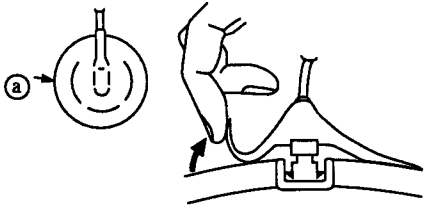

- ① Turn up one side of the rubber cap in the direction indicated by the arrow ①.

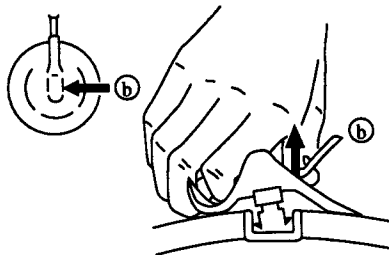

- ② Using a thumb pull up the rubber cap firmly in the direction indicated by the arrow ②.

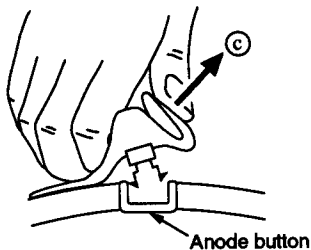

- ③ When one side of the rubber cap is separated from the anode button, the anode-cap can be removed by turning up the rubber cap and pulling up it in the direction of the arrow ③.

### • HOW TO HANDLE AN ANODE-CAP

- ① Don't hurt the surface of anode-caps with sharp shaped material!
- ② Don't press the rubber hardy not to hurt inside of anode-caps! A material fitting called as shatter-hook terminal is built in the rubber.
- ③ Don't turn the foot of rubber over hardy! The shatter-hook terminal will stick out or hurt the rubber.

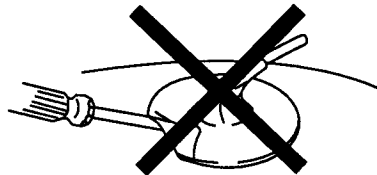
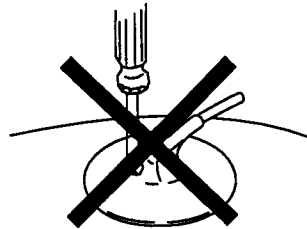

## SECTION 3

### SAFETY RELATED ADJUSTMENTS

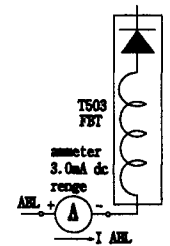
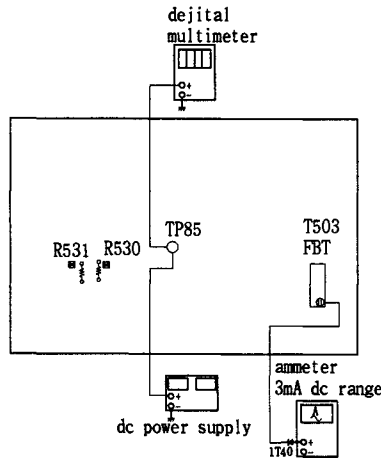
ADJUSTMENT ITEM AND PROCEDURE	EQUIPMENT AND SIGNAL	MEASUREMENT POSITION	ADJUSTMENT LOCATION	ILLUSTRATION AND SHAPE AND NUMBER
<div style="border: 1px solid black; padding: 5px; margin-bottom: 10px;"> <p><b>☒ *RESISTOR CONFIRMATION METHOD ( HOLD-DOWN CONFIRMATION) AND READJUSTMENTS</b></p> </div> <p>The following adjustments should always be performed when replacing the following components (*marked with ☒ on the schematic diagram). (Hold-down operation confirmation)</p> <p><b>Step 1</b></p> <p>1. Preparation before confirmation</p> <ol style="list-style-type: none"> <li>1) Turn the POWER switch ON, and receive *signal and set the *PICTURE and BRIGHTNESS controls to adjustment.</li> <li>2) Confirm that the voltage of the check terminal of *TP is more than *voltage when the set is operating normally with *Power supply.</li> </ol> <p><b>Step 2</b></p> <p>2. Confirm that a I ABL.</p> <p><b>Step 3</b></p> <p>4. Using an external DC power supply, apply voltage between TP 85 and ground. Increase gradually the voltage and confirm that the hold-down works (Raster disappears) at lower than the voltg obtained Step 2 mentioned above *voltage.</p> <p><b>Step 4</b></p> <p>5. Confirm that a voltage of more than *voltage appears TP85 and ground.</p>	<p>* White Picture</p> <p>*Digital multimeter</p> <p>* White Picture</p> <p>* White Picture</p>	<p>*☒ marked parts IC643,IC351,IC501 D519,D520,D521, C531,C532, R387,R529,R530,R531 R532,R533,R550,R661 T503</p> <p>*TP85 (H. PROT)</p>	<p>*☒ R530,531</p> <p>*PICTURE BRIGHTNESS } ..... maximum }</p>  <p>*PICTURE BRIGHTNESS } ..... maximum }</p>	<p>A BOARD - CONDUCTOR SIDE -</p>  <p>[Check Condition]Step 1</p> <ul style="list-style-type: none"> <li>*more than 18.0VDC (32/34 inch only)</li> <li>*more than 21.0VDC (27/29 inch only)</li> <li>*130 <math>\pm 2.0</math> VAC (Power Supply) (except 29V35C/34V35C)</li> <li>*220 <math>\pm 2.0</math> VAC (Power Supply) (29V35C/34V35C only)</li> </ul> <p>[Check Condition]Step 2</p> <ul style="list-style-type: none"> <li>*1760 <math>\pm 100</math> <math>\mu</math>A (27/29 inch only)</li> <li>*2160 <math>\pm 100</math> <math>\mu</math>A (32/34 inch only)</li> <li>*130 <math>\pm 2.0</math> VAC (Power Supply) (except 29V35C/34V35C)</li> <li>*220 <math>\pm 2.0</math> VAC (Power Supply) (29V35C/34V35C only)</li> </ul> <p>[Check Condition]Step 3</p> <ul style="list-style-type: none"> <li>*lower than 22.05 VDC (32/34 inch only)</li> <li>*lower than 26.05 VDC (27/29 inch only)</li> <li>*130 <math>\pm 2.0</math> VAC (Power Supply) (except 29V35C/34V35C)</li> <li>*220 <math>\pm 2.0</math> VAC (Power Supply) (29V35C/34V35C only)</li> </ul> <p>[Check Condition]Step 4</p> <ul style="list-style-type: none"> <li>*more than 18.0VDC (32/34 inch only)</li> <li>*more than 21.0VDC (27/29 inch only)</li> <li>*130 <math>\pm 2.0</math> VAC (Power Supply) (except 29V35C/34V35C)</li> <li>*220 <math>\pm 2.0</math> VAC (Power Supply) (29V35C/34V35C only)</li> </ul>

ADJUSTMENT ITEM AND PROCEDURE	EQUIPMENT AND SIGNAL	MEASUREMENT POSITION	ADJUSTMENT LOCATION	ILLUSTRATION AND SHAPE AND NUMBER
<p><b>B+ VOLTAGE CONFIRMATION</b></p> <p>The following adjustments should always be performed when replacing the following *components.</p> <ol style="list-style-type: none"> <li>1) Supply *Voltage AC to with *variable auto-transformer.</li> <li>2) Input an entirely *signal.</li> <li>3) Set the PICTURE control and the BRIGHTNESS control to adjustment.</li> <li>4) Confirm the voltage of *TP is less than *Voltage DC.</li> <li>5) If step 4) is not satisfied, replace the *components repeat above steps.</li> </ol>	<p>*Variable auto-transformer *Monoscope</p>	<p>*IC643, R661</p> <p>*G Board CN641 Pin 1 - ground</p>	<p>*PICTURE, BRIGHTNESS ..... initial reset</p> <p>*R661</p>	<p>*130 <math>\pm 2^0</math> VAC (except 29V35C/34V35C) *220 <math>\pm 3^0</math> VAC (29V35C/34V35C only)</p> <p>*Less than 136.5 VDC</p>

SECTION 4  
DIAGRAMS

4-1. BLOCK DIAGRAMS

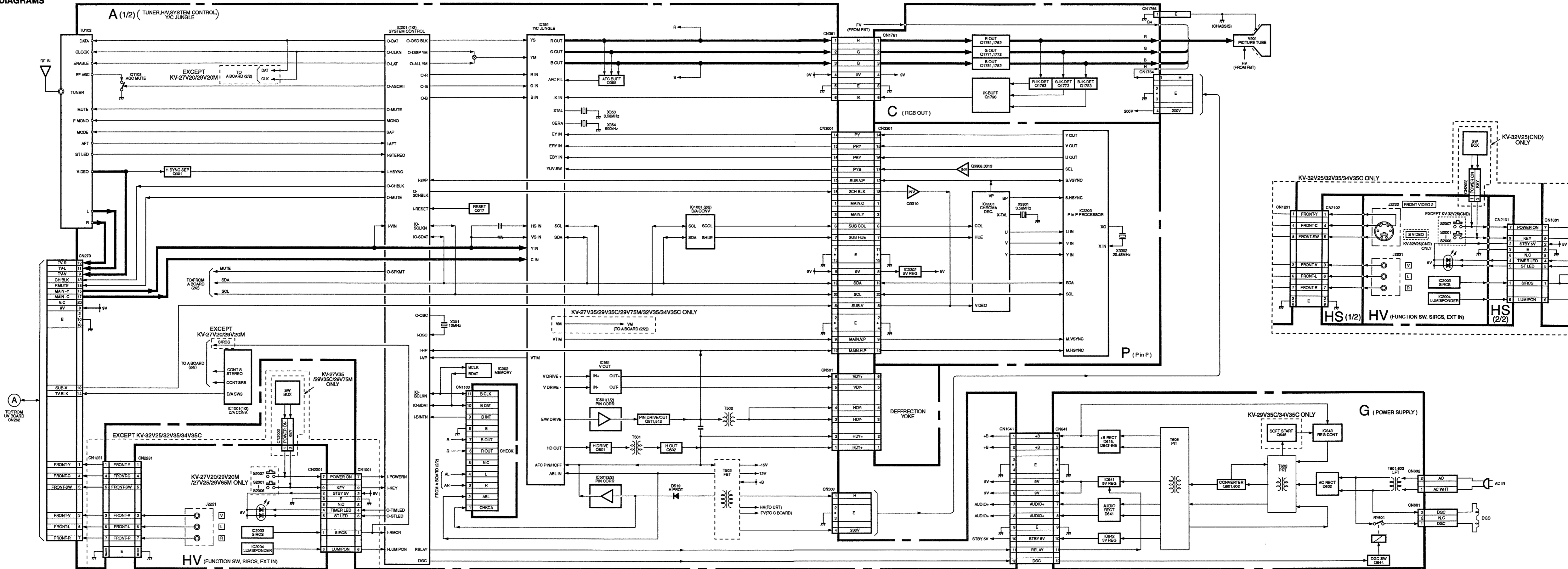



#### 4-2. CIRCUIT BOARDS LOCATION

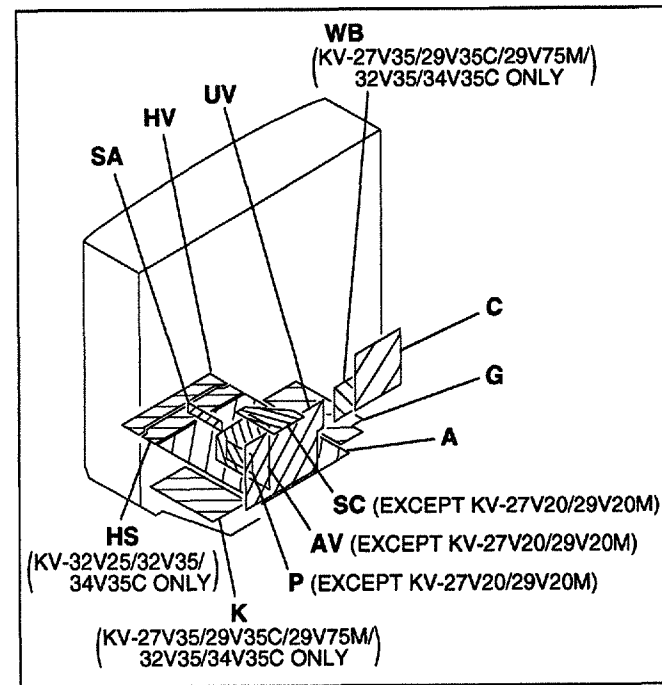

#### 4-3. PRINTED WIRING BOARDS AND SCHEMATIC DIAGRAMS

- Note:
- All capacitors are in  $\mu\text{F}$  unless otherwise noted.  $\text{pF}$ :  $\mu\text{F}$  50VV or less are not indicated except for electrolytics and tantalums.
  - All electrolytics are in 50V unless otherwise specified.
  - All resistors are in ohms.
  - $\text{k}\Omega = 1000\Omega$ ,  $\text{M}\Omega = 1000\text{k}\Omega$
  - Indication of resistance, which does not have one for rating electrical power, is as follows.

Pitch: 5 mm  
Rating electrical power: 1/4W

- 1/4W in resistance, 1/10W and 1/8W in chip resistance.
- : nonflammable resistor.
- : fusible resistor.
- : internal component.
- : panel designation and adjustment for repair.
- All variable and adjustable resistors have characteristic curve B, unless otherwise noted.
- The components identified by in this basic schematic diagram have been carefully factory-selected for each set in order to satisfy regulations regarding X-ray radiation.
- Should replacement be required, replace only with the value originally used.
- When replacing components identified by , make the necessary adjustments indicated. If results do not meet the specified value, change the component identified by and repeat the adjustment until the specified value is achieved. (Refer to R530 and R531 adjustment on Page 25, 26.)
- When replacing the part in below table, be sure to perform the related adjustment.

Part replaced ()	Adjustment ()
IC351, IC501, D519, D520, D521, C531, C532, R387, R529, R530, R531, R532, R533, R550, T503 ..... A BOARD	R530, R531
IC643, R661 ..... G BOARD	

- As to the voltage value shown by the semiconductors on the Schematic Diagram, see the another list.
- Readings are taken with a color-bar signal input.
- Readings are taken with a 10M $\Omega$  digital multimeter.
- Voltages are dc with respect to ground unless otherwise noted.
- Voltage variations may be noted due to normal production tolerances.
- All voltages are in V.
- S: Measurement impossibility.
- : B + line.
- : B - line.
- (Actual measured value may be different).
- : signal path. (HP)
- Circled numbers are waveform reference.

#### Reference information

- RESISTOR :
- RN METAL FILM
  - RC SOLID
  - FPRD NONFRAMMABLE CARBON
  - FUSE NONFRAMMABLE FUSIBLE
  - RW NONFRAMMABLE WIREWOUND
  - RS NONFRAMMABLE METAL OXIDE
  - RB NONFRAMMABLE CEMENT
  - ※ ADJUSTMENT RESISTOR
- COIL :
- LF-8L MICRO INDUCTOR
- CAPACITOR :
- TA TANTALUM
  - PS STYROL
  - PP POLYPROPYLENE
  - PT MYLAR
  - MPS METALIZED POLYESTER
  - MPP METALIZED POLYPROPYLENE
  - ALB BIPOlar
  - ALT HIGH TEMPERATURE
  - ALR HIGH RIPPLE

Note: The symbol display is on the component side.

The components identified by shading and mark are critical for safety. Replace only with part number specified.

The symbol indicate fast operating fuse. Replace only with fuse of same rating as marked.

Note: Les composants identifiés par un trame et une marque sont critiques pour la sécurité. Ne les remplacer que par une pièce portant le numéro spécifié.

Le symbole indique une fusible à action rapide. Doit être remplacé par une fusible de même valeur, comme marqué.

#### P BOARD IC VOLTAGE LIST

IC	pin	volt	pin	volt	
IC3301	1	GND	4	2.3	
	2	NC	5	5.1	
	3	GND	6	GND	
	4	4.0	7	0.5	
	5	6.8	8	0	
	6	GND	9	0.6	
	7	0.2	10	5.2	
	8	0	11	2.1	
	9	1.8	12	0.3	
	10	0.3	13	NC	
	11	8.2	14	-3.0	
	12	8.2	15	GND	
	13	3.9	16	GND	
	14	3.4	17	0.7	
	15	0	18	0.5	
IC3302	IN	9.1	28	2.3	
	OUT	5.3	29	5.2	
	IC3303	1	GND	30	2.6
		2	3.2	31	4.2
3	2.6	32	2.5		

All voltages are in V

#### P BOARD WAVEFORMS

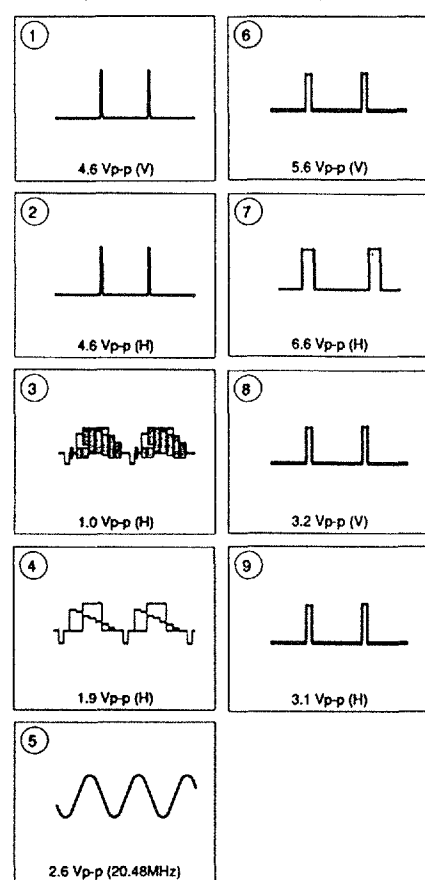

#### P BOARD TRANSISTOR VOLTAGE LIST

	B	C	E
Q3301	5.3	9.1	4.7
Q3305	0.5	GND	1.2
Q3306	0.8	GND	1.4
Q3307	0.6	GND	1.3
Q3308	0	GND	2.8
Q3310	0	5.2	GND
Q3312	0	0	0.8
Q3313	0.8	0.4	GND

All voltages are in V

#### P [P IN P] (EXCEPT KV-27V20/29V20M)

- P BOARD - <Component Side>

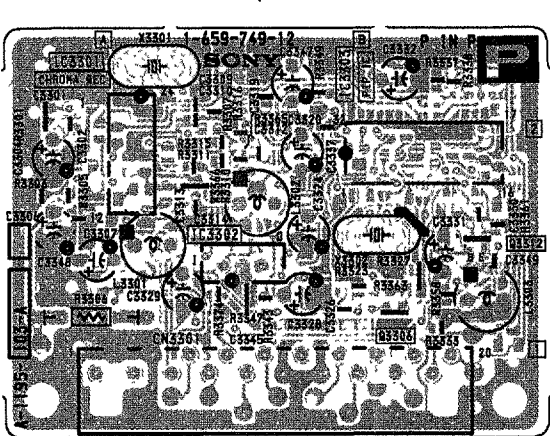

<Conductor Side>

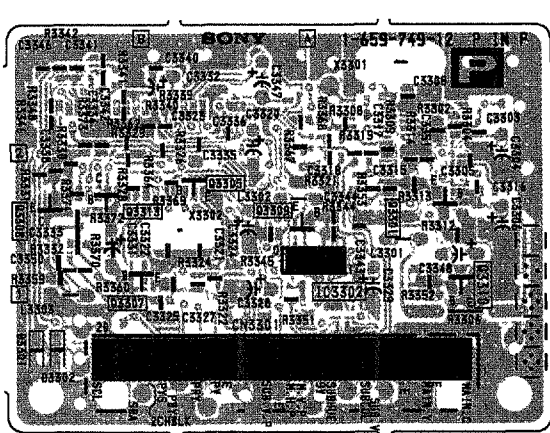

- : Pattern from the side which enables seeing.
- : Pattern of the rear side.

(EXCEPT KV-27V20/29V20M)

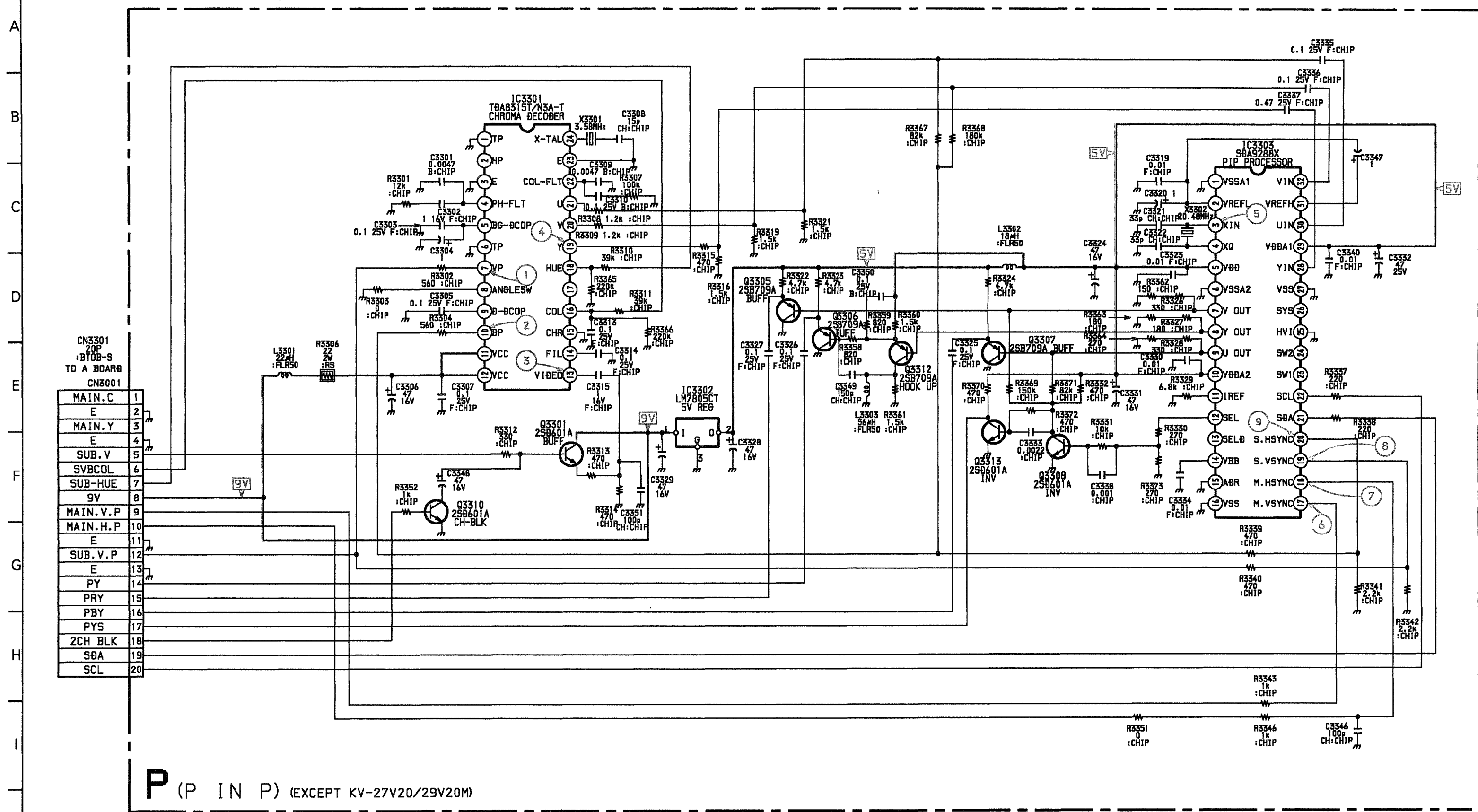

P (P IN P) (EXCEPT KV-27V20/29V20M)

B-95538<U>C>-P..

**A** MICON, Y/CJ, TUNER, PIP, VOL-CTL  
AUDIO-AMP, PIN-MOD, V.DEF, H.DEF, AV-SW

- A BOARD -

**A BOARD**

IC	Q1102 B-12	Q1103 A-10	Q1231 E-13	Q1232 E-13
<b>DIODE</b>				
IC001 B-4	D001 A-6	D002 D-3	D003 A-6	D004 C-9
IC002 C-3	D005 A-6	D006 A-6	D007 A-6	D008 A-6
IC351 D-6	D009 A-6	D010 A-6	D011 A-6	D012 A-6
IC461 G-5	D013 C-5	D014 D-3	D015 C-4	D353 D-8
IC501 H-3	D016 D-3	D356 E-3	D360 E-7	D362 E-8
IC511 G-8	D017 C-5	D368 C-8	D462 F-1	D501 I-3
IC1001 D-9	D018 D-3	D502 I-9	D503 I-9	D504 J-8
IC1401 E-11	D019 D-3	D505 I-7	D506 I-6	D507 I-4
IC1402 E-12	D020 D-3	D508 I-6	D515 H-5	D516 I-3
<b>TRANSISTOR</b>				
Q001 A-6	D517 I-4	D518 I-4	D519 F-9	D520 H-3
Q002 C-5	D519 F-9	D521 H-3	D522 H-3	D523 H-3
Q003 I-2	D520 H-3	D521 H-3	D522 H-3	D523 H-3
Q004 I-2	D521 H-3	D522 H-3	D523 H-3	D524 H-3
Q010 D-4	D522 H-3	D523 H-3	D524 H-3	D525 H-3
Q011 D-4	D523 H-3	D524 H-3	D525 H-3	D526 H-3
Q012 D-4	D524 H-3	D525 H-3	D526 H-3	D527 H-3
Q013 E-4	D525 H-3	D526 H-3	D527 H-3	D528 H-3
Q014 D-4	D526 H-3	D527 H-3	D528 H-3	D529 H-3
Q015 D-4	D527 H-3	D528 H-3	D529 H-3	D530 H-3
Q016 D-3	D528 H-3	D529 H-3	D530 H-3	D531 F-12
Q017 A-5	D529 H-3	D530 H-3	D531 F-12	D532 G-9
Q301 D-8	D530 H-3	D531 F-12	D532 G-9	D561 G-8
Q302 D-8	D531 F-12	D532 G-9	D561 G-8	D562 G-3
Q303 D-8	D532 G-9	D561 G-8	D562 G-3	D1102 B-10
Q354 E-8	D561 G-8	D562 G-3	D1103 B-12	D1248 E-12
Q356 C-5	D562 G-3	D1102 B-10	D1103 B-12	D1263 D-10
Q357 E-5	D1102 B-10	D1103 B-12	D1248 E-12	D1264 E-10
Q358 E-8	D1103 B-12	D1248 E-12	D1263 D-10	
Q461 G-4	D1248 E-12	D1263 D-10		
Q462 G-4	D1263 D-10			
Q501 J-4				
Q502 J-9				
Q503 H-3				
Q511 I-3				
Q512 H-5				
Q561 F-7				
Q562 F-7				
Q563 H-3				

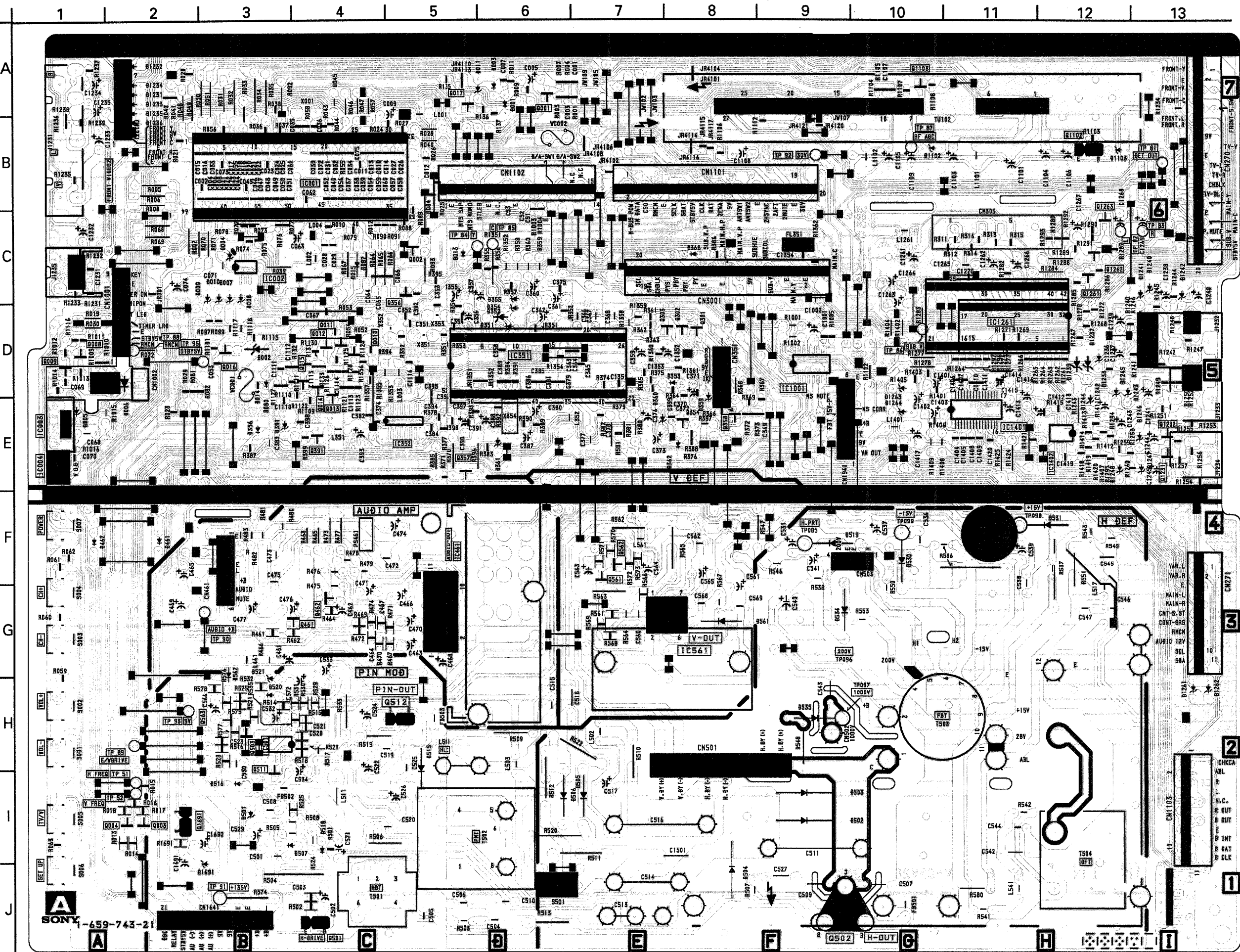

Schematic diagram  
← board

**A BOARD IC1001 CXA1315M**

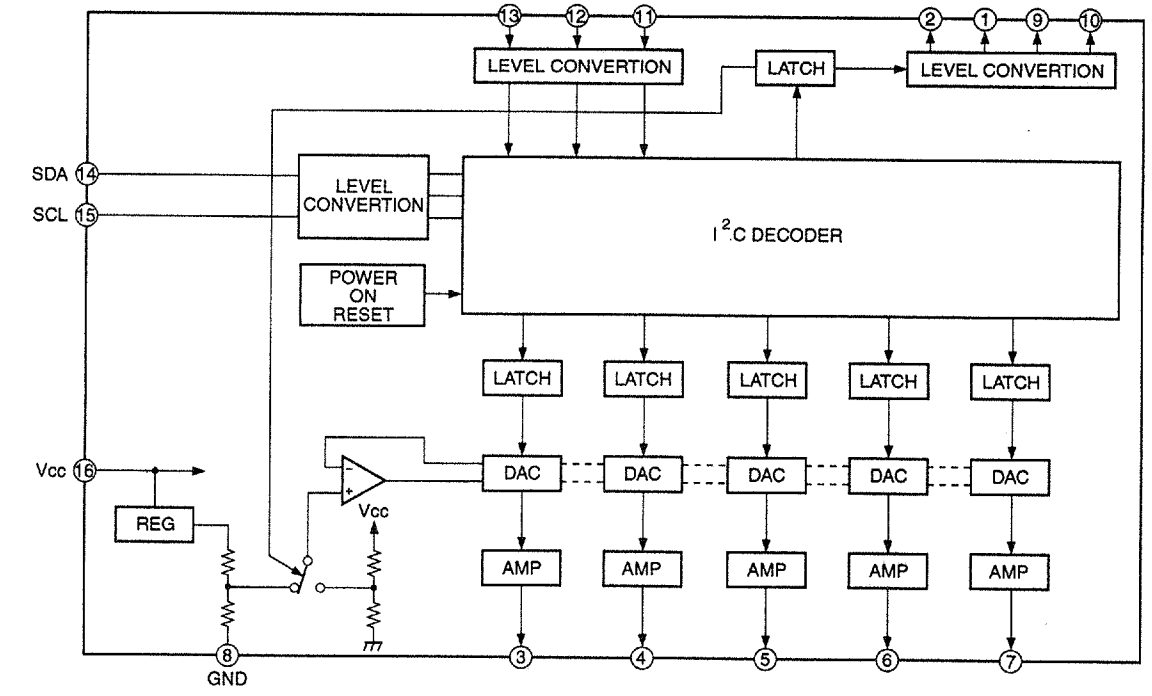

**A BOARD IC461 TDA2009A**

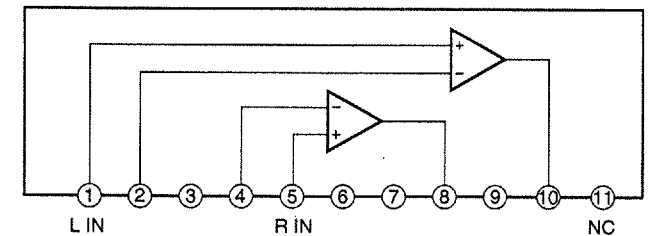

**A BOARD IC561 TDA8172**

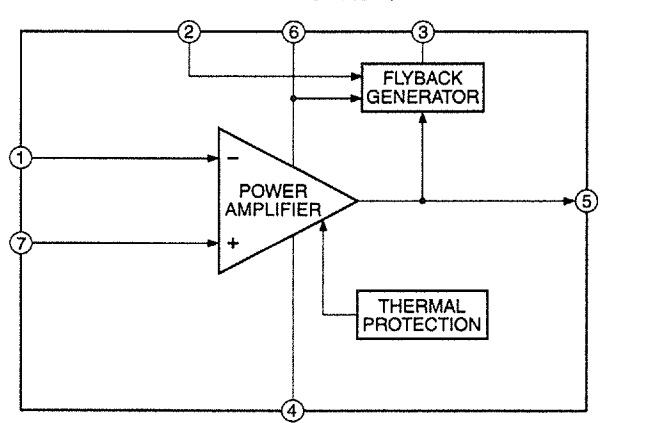

**A BOARD IC1402 NJM4558M**

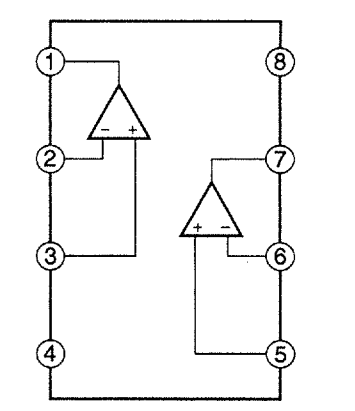

**NOTE:**  
The circuit indicated as left contains high voltage of over 600 Vp-p. Care must be paid to prevent an electric shock in inspection or repairing.

**A BOARD \* MARK LIST**

	KV-27V20/29V20M	KV-27V25/29V65M	KV-27V35/29V35C/29V75M	KV-32V25	KV-32V35/34V35C
C360	#	0.47	0.47	0.47	0.47
C361	#	0.47	0.47	0.47	0.47
C362	#	0.47	0.47	0.47	0.47
C375	0.1 F:CHIP	#	#	#	#
C461	22 25V	22 25V	4.7	10	#
C476	1000 25V	1000 25V	JW (5)	1000 25V	JW (5)
C477	1000 25V	1000 25V	JW (5)	1000 25V	JW (5)
C520	0.0022 500V	0.0022 500V	0.0022 500V	0.001 500V	0.001 500V
C1501	#	#	#	0.12 200V-PP	0.12 200V-PP
CN481	4P WHT :S-MICRO	4P WHT :S-MICRO	7P WHT :S-MICRO	4P WHT :S-MICRO	7P WHT :S-MICRO
CN1101	#	#	20P :BTOB-P	20P :BTOB-P	20P :BTOB-P
CN1941	#	#	5P WHT :S-MICRO	#	5P WHT :S-MICRO
JR351	0 :CHIP	#	#	#	#
JR352	0 :CHIP	#	#	#	#
L461	10uH :FLR50	10uH :FLR50	18uH :FLR50	15uH :FLR50	#
Q357	#	#	2SD601A	#	2SD601A
R006	#	220	220	220	220
R008	#	220	220	220	220
R022	JW (7.5)	10k	10k	10k	10k
R027	#	1k :CHIP	1k :CHIP	1k :CHIP	1k :CHIP
R031	#	220	220	220	220
R040	#	220	220	220	220
R041	#	4.7k :CHIP	4.7k :CHIP	4.7k :CHIP	4.7k :CHIP
R042	#	4.7k :CHIP	4.7k :CHIP	4.7k :CHIP	4.7k :CHIP
R045	#	220	220	220	220
R050	#	220	220	220	220
R090	#	220 :CHIP	220 :CHIP	220 :CHIP	220 :CHIP
R058	#	220	220	220	220
R059	#	220	220	220	220
R360	#	220	220	220	220
R370	#	1k	#	#	1k
R371	#	1.5k :CHIP	#	#	1.5k :CHIP
R372	#	1k :CHIP	#	#	1k :CHIP
R396	#	1k	#	#	1k
R466	2.2 :FPRD	2.2 :FPRD	1.5 :FPRD	2.2 :FPRD	#
R469	1.8k :CHIP	1.8k :CHIP	5.6k :CHIP	1.8k :CHIP	3.3k :CHIP
R472	1.8k :CHIP	1.8k :CHIP	5.6k :CHIP	1.8k :CHIP	3.3k :CHIP
R482	2.2k	2.2k	#	2.2k	#
R483	2.2k	2.2k	#	2.2k	#
R511	56 2W :RS	56 2W :RS	68 2W :RS	68 2W :RS	68 2W :RS
R512	82 2W :RS	82 2W :RS	100 2W :RS	100 2W :RS	100 2W :RS
R513	0.68 1W :RS	0.68 1W :RS	0.68 1W :RS	0.22 1W :RS	0.22 1W :RS
R530	20k :RN-CP	20k :RN-CP	20k :RN-CP	12k :RN-CP	12k :RN-CP
R531	24k :RN-CP	24k :RN-CP	24k :RN-CP	68k :RN-CP	68k :RN-CP
R546	30k :RN	30k :RN	22k :RN	22k :RN	22k :RN
R564	8.2	8.2	8.2	10	10

# Mark : not mounted

**A BOARD IC1401 BH3856FS**

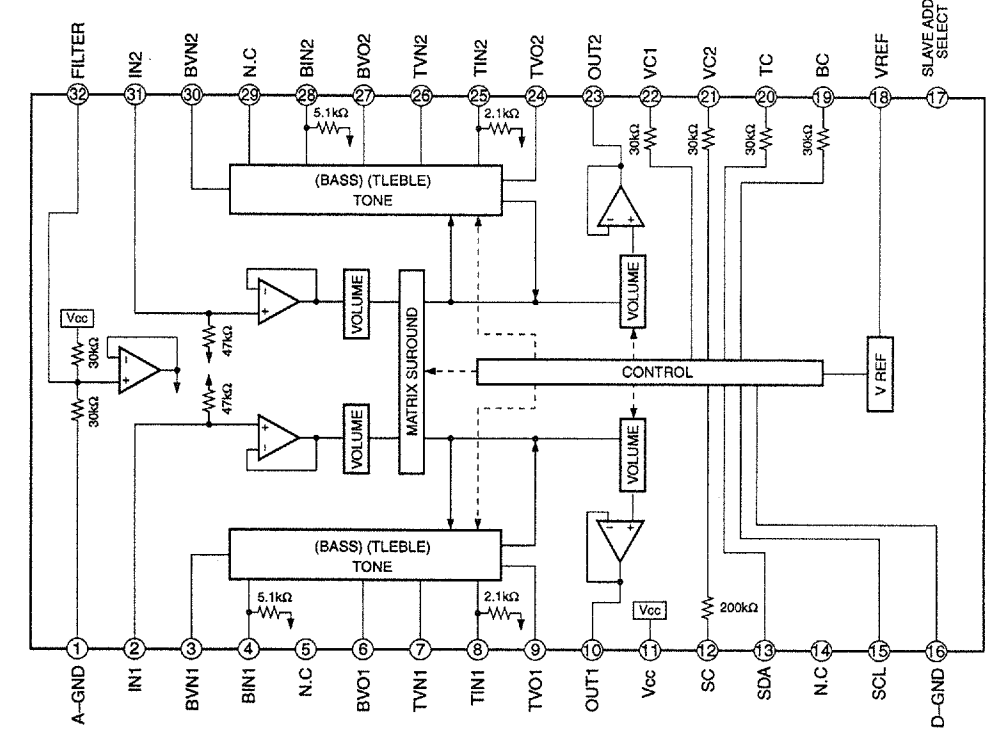





**UV** [AV SW, EXT IN/OUT,  
AUDIO SW, AUDIO BUFF.]

- UV BOARD -

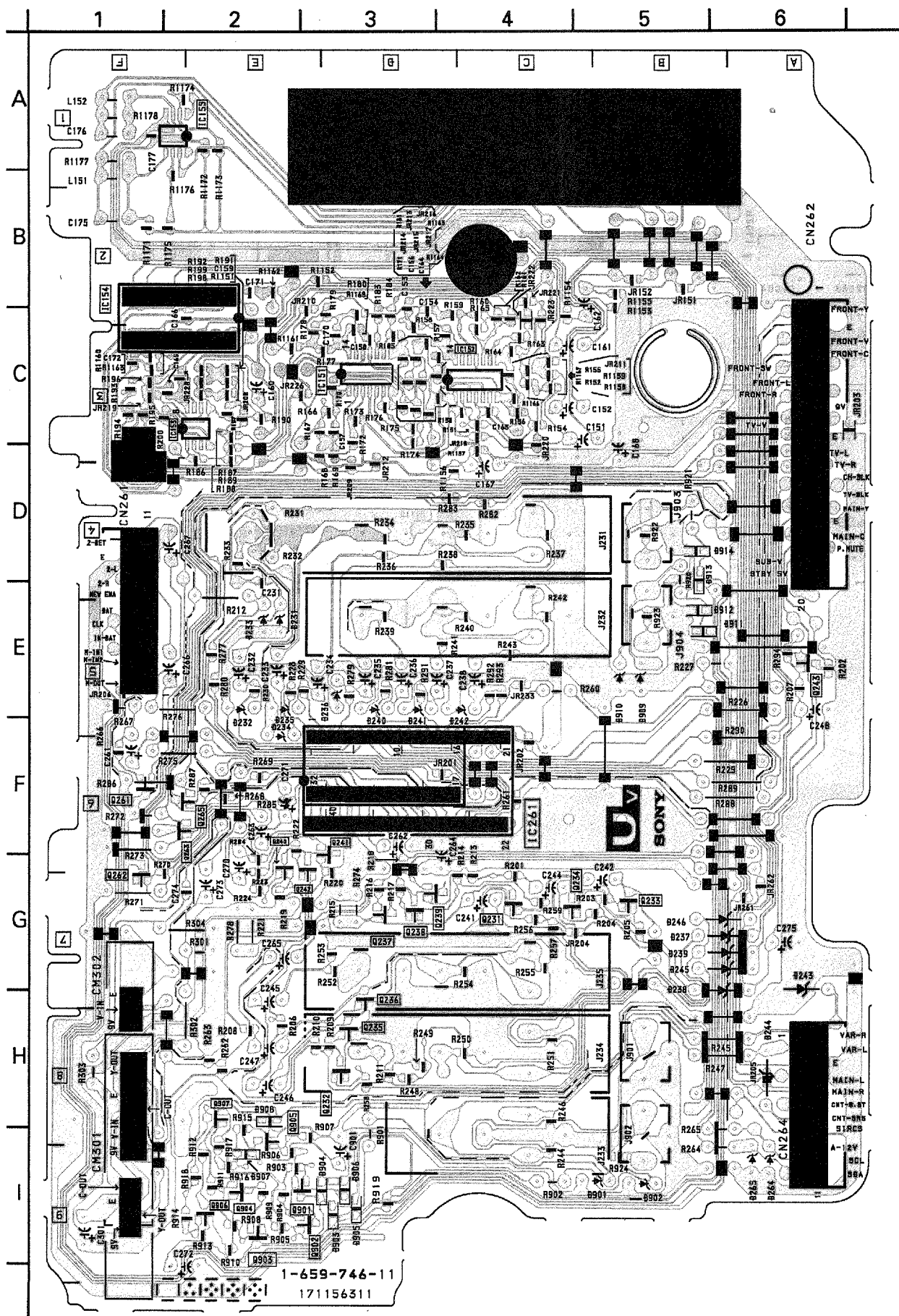

**UV BOARD**

IC	
IC151	C-3
IC152	C-4
IC153	C-2
IC154	C-2
IC261	F-4

**TRANSISTOR**

Q231	G-4
Q232	H-3
Q233	G-5
Q234	G-5
Q235	H-3
Q236	H-3
Q237	G-3
Q238	G-3
Q239	G-4
Q240	G-2
Q241	G-3
Q242	G-3
Q243	E-6
Q261	F-1
Q262	G-1
Q263	F-2
Q265	F-2

**DIODE**

D231	E-2
D232	E-2
D233	E-2
D234	F-2
D235	E-2
D236	E-3
D237	G-6
D238	G-6
D239	G-6
D240	E-3
D241	E-3
D242	E-4
D243	G-6
D244	H-6
D245	G-6
D246	G-6
D264	I-6
D265	I-6
D902	I-5
D909	E-5
D910	E-5

**WB** [VELOCITY MOD.] (KV-27V35/29V35C/29V75M/32V35/34V35C ONLY)

**SC** (EXCEPT KV-27V20/29V20M)

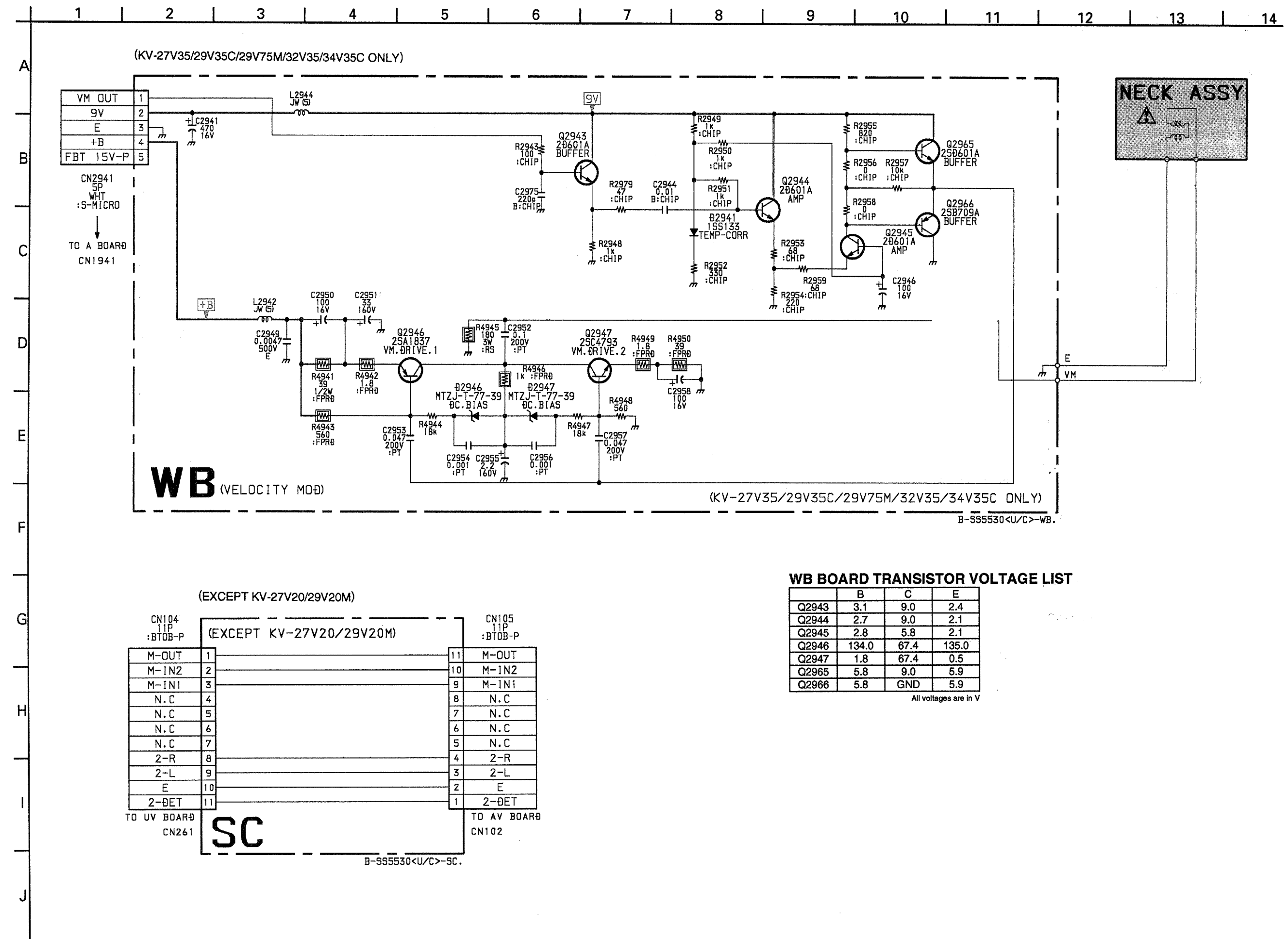
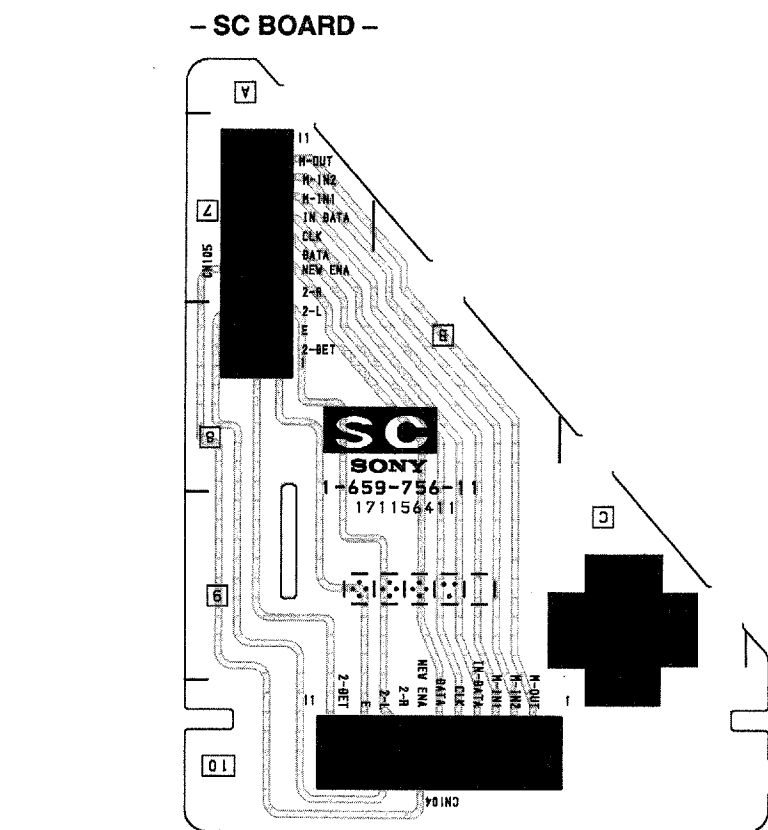
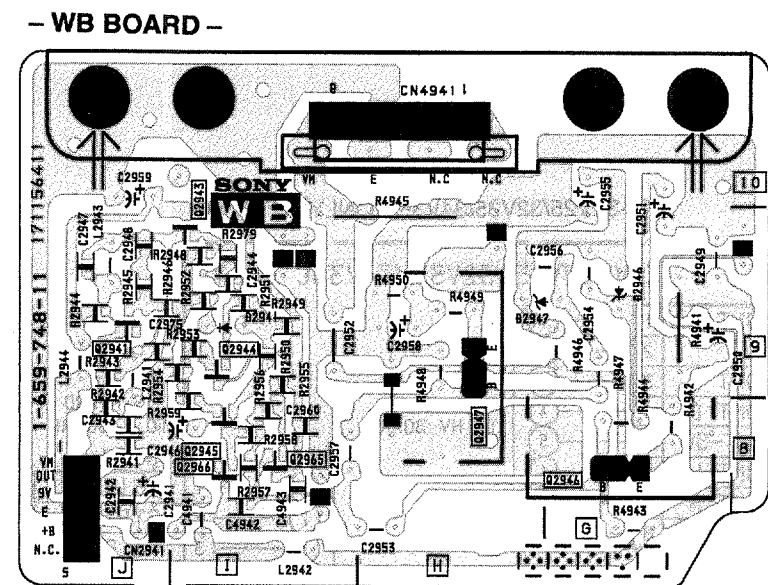

**WB** (VELOCITY MOD.)

(EXCEPT KV-27V20/29V20M)

TO UV BOARD CN261		TO AV BOARD CN102	
M-OUT	1	11	M-OUT
M-IN2	2	10	M-IN2
M-IN1	3	9	M-IN1
N.C	4	8	N.C
N.C	5	7	N.C
N.C	6	6	N.C
N.C	7	5	N.C
2-R	8	4	2-R
2-L	9	3	2-L
E	10	2	E
2-DET	11	1	2-DET

B-SS5530<U/C>-SC.

**WB BOARD TRANSISTOR VOLTAGE LIST**

	B	C	E
Q2943	3.1	9.0	2.4
Q2944	2.7	9.0	2.1
Q2945	2.8	5.8	2.1
Q2946	134.0	67.4	135.0
Q2947	1.8	67.4	0.5
Q2965	5.8	9.0	5.9
Q2966	5.8	GND	5.9

All voltages are in V



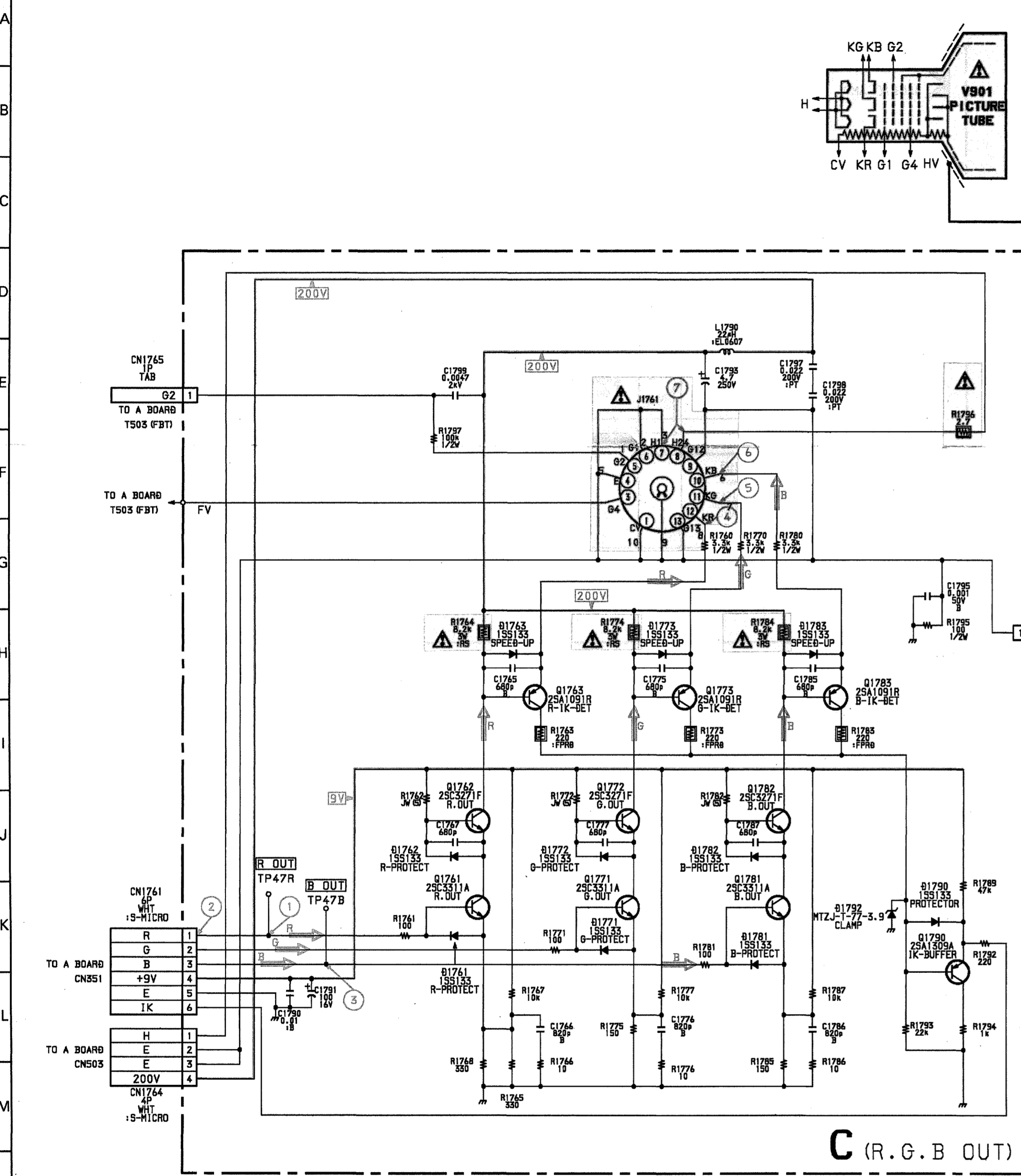

**C BOARD TRANSISTOR VOLTAGE LIST**

	B	C	E
Q1761	2.2	8.2	1.7
Q1762	8.7	134.1	8.2
Q1763	134.1	2.3	132.0
Q1771	1.8	8.2	1.3
Q1772	8.7	146.4	8.2
Q1773	146.4	2.3	144.1
Q1781	2.1	8.2	1.6
Q1782	8.7	133.7	8.2
Q1783	133.7	2.3	131.5
Q1790	2.2	0.2	2.5

All voltages are in V

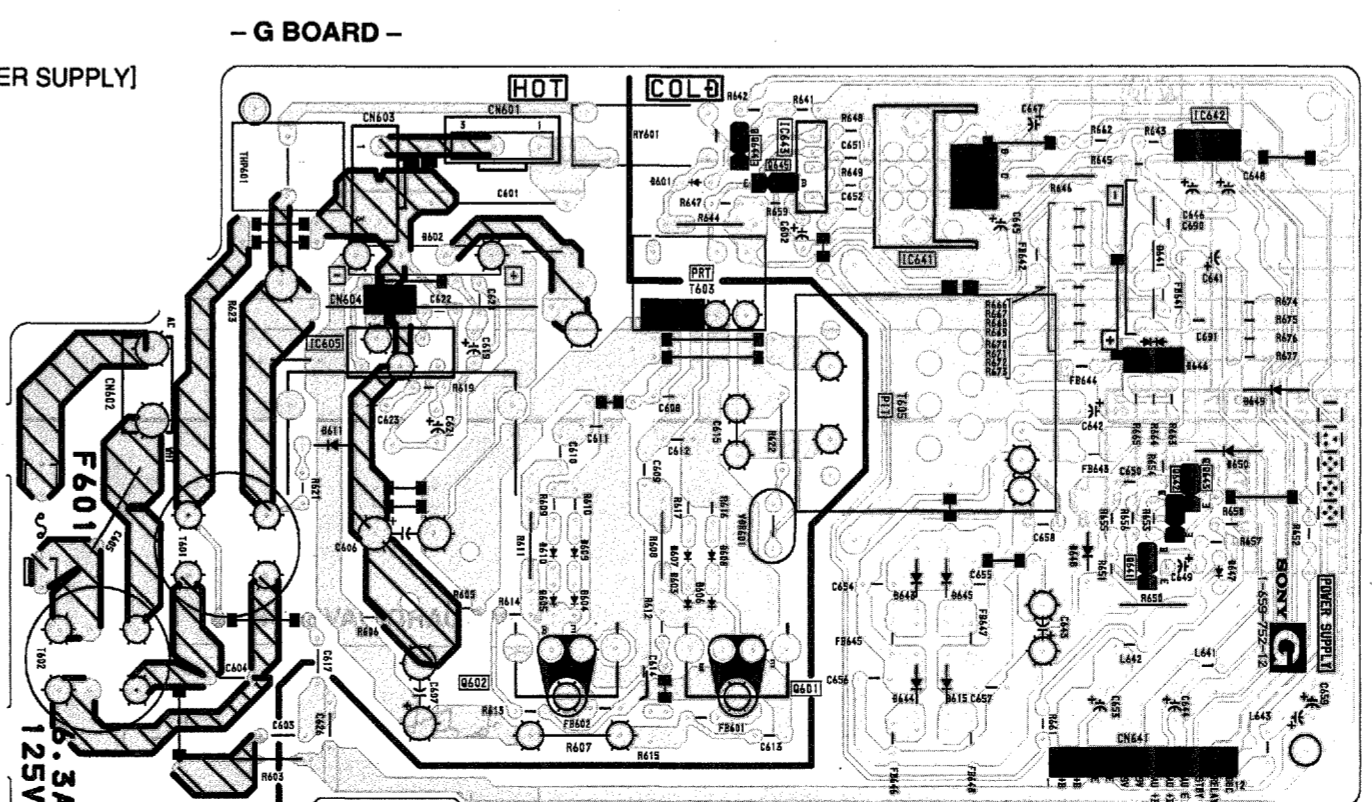
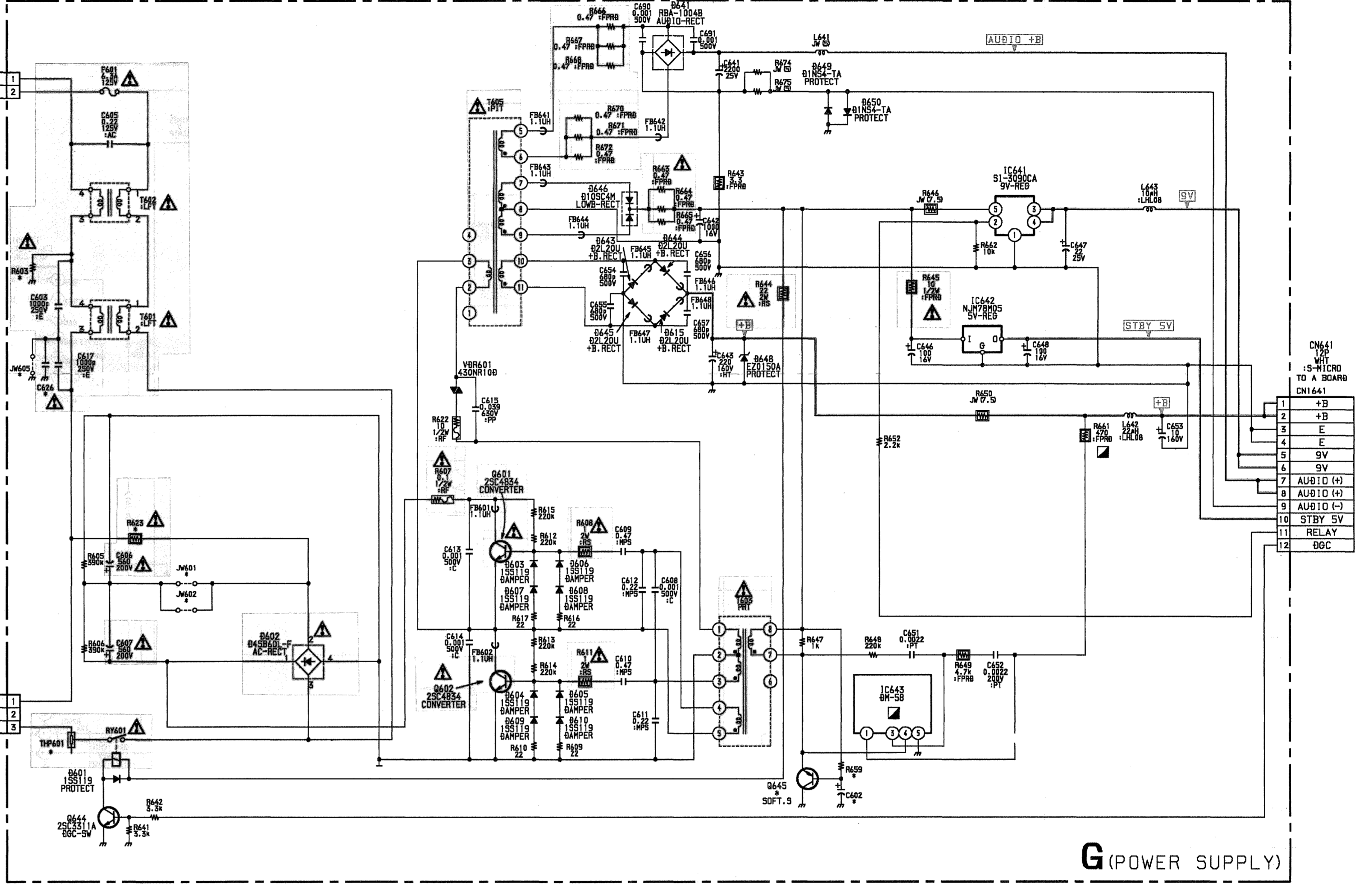
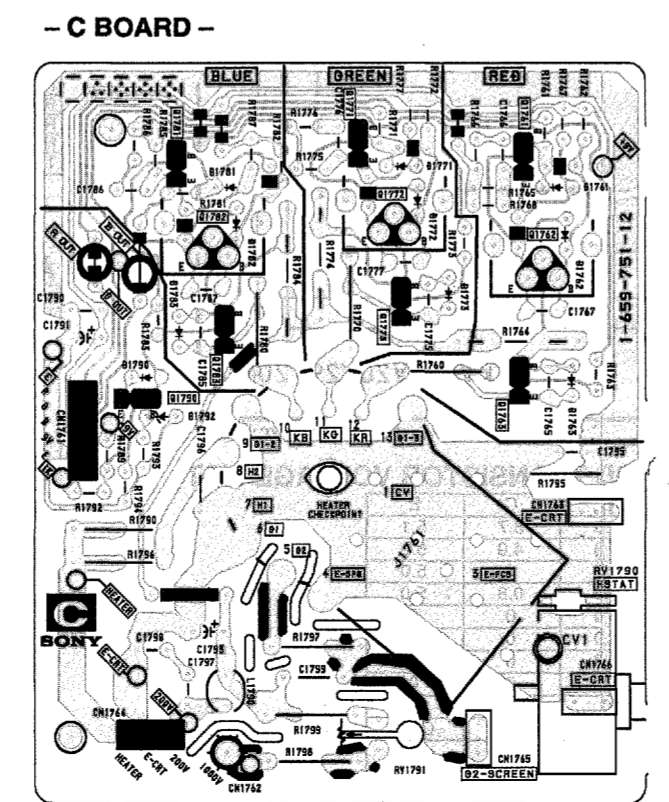
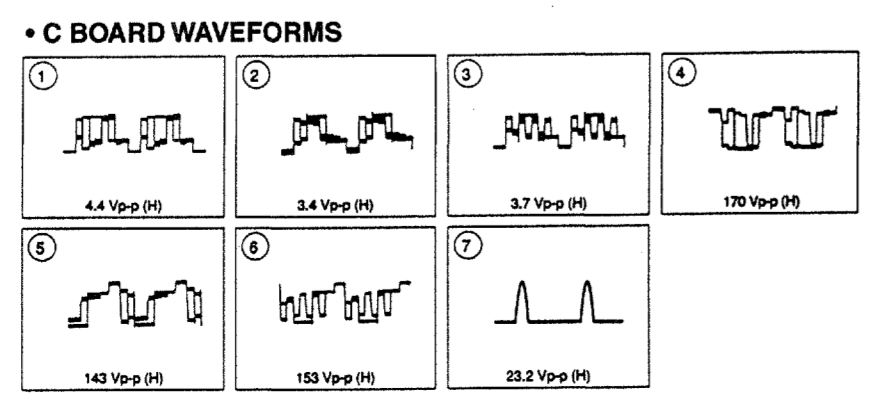

**G BOARD TRANSISTOR VOLTAGE LIST**

	B	C	E
Q801	145.2	294.0	147.5
Q802	-1.7	147.5	GND
Q844	0	10.5	GND

All voltages are in V

**G BOARD IC VOLTAGE LIST**

IC	pin	volt
IC641	1	GND
	2	3.9
	3	8.9
	4	8.9
IC642	IN	9.5
	OUT	5.0
IC643	1	135
	2	NC
	3	2.5
	4	7.8
	5	GND

All voltages are in V

**G BOARD \* MARK LIST**

	EXCEPT KV-29V35C/34V35C	KV-29V35C/34V35C
CB02	#	4.7
CB29	#	1000 250V
F601	6.3A 125V	6.3A 250V
JW601	5MM	#
JW602	5MM	#
JW605	7.5MM	#
CB45	#	2SA1309A
R603	2.2M 1/2W	8.2M 1W
R623	1 20W -RB	3.9 20W -RB
R659	#	10K
THP601	1-809-539-11	1-809-827-11

# Mark : not mounted

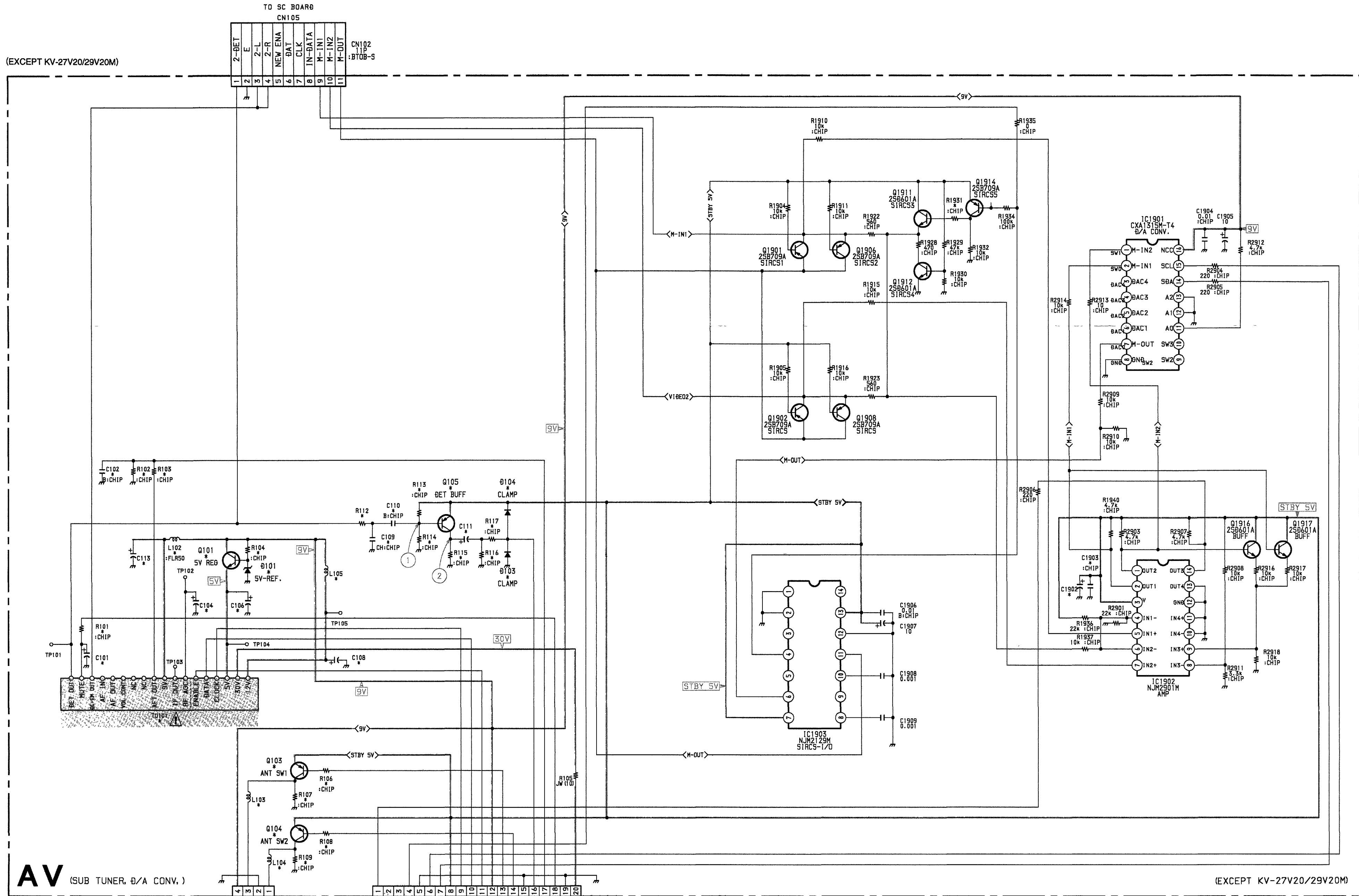

AV (SUB TUNER, D/A CONV.)

(EXCEPT KV-27V20/29V20M)

**AV BOARD TRANSISTOR VOLTAGE LIST**

Q	B	C	E
Q101	5.8	8.7	5.1
Q103	4.3	4.9	5.0
Q104	5.0	0	5.0
Q105	5.0	0.8	5.0
Q1901	5.0	0	0
Q1902	5.0	0	0
Q1908	5.0	0	0
Q1911	0.7	5.0	0
Q1912	0.7	0	GND
Q1914	4.9	0	5.0
Q1916	0.2	5.0	0
Q1917	0.2	5.0	0

All voltages are in V

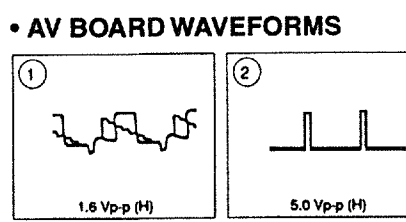

(KV-27V35/29V35C/29V75M/32V35/34V35C ONLY)

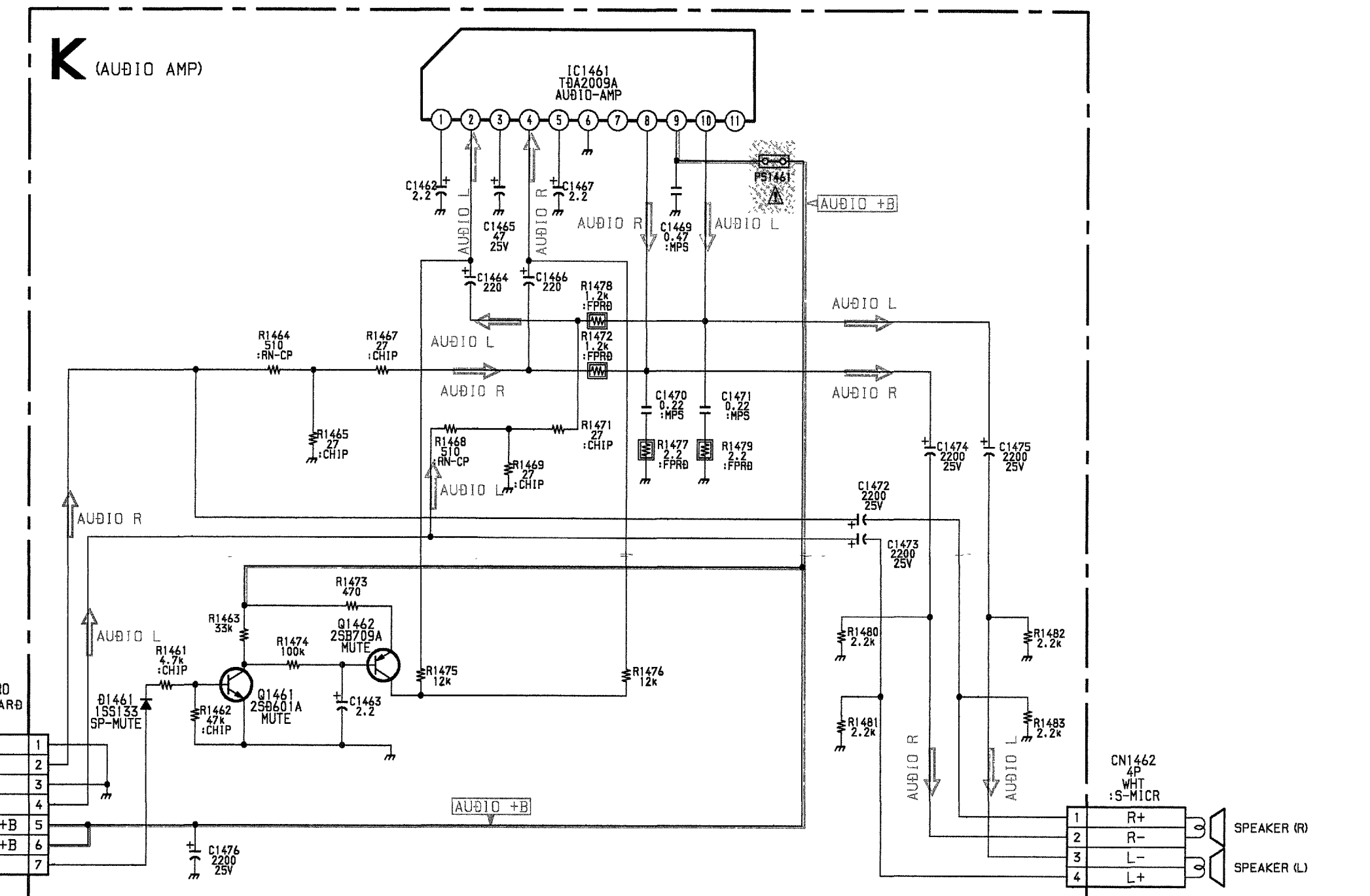

**AV BOARD \* MARK LIST**

Part	Value	Part	Value
C101	10K	C1903	10K
C102	0.0022	C1904	10K
C104	10	C1905	10K
C105	47 25V	C1906	10K
C106	100 16V	C1907	10K
C108	2200	C1908	10K
C110	0.047	C1909	10K
C111	10	C1910	10K
C113	220 16V	C1911	10K
CN103	4P BLK 3S-MICRO	C1912	10K
D101	MTZ21-7.5-RC	C1913	10K
D103	1SS133	C1914	10K
D104	1SS133	C1915	10K
L102	100H FLR50	C1916	10K
L103	100H FLR50	C1917	10K
L104	100H FLR50	C1918	10K
L105	100H FLR50	C1919	10K
Q101	2SB2311A	C1920	10K
Q103	2SB709A	C1921	10K
Q104	2SB709A	C1922	10K
Q105	2SB709A	C1923	10K
Q106	2SB709A	C1924	10K
Q107	2SB709A	C1925	10K
Q108	2SB709A	C1926	10K
Q109	2SB709A	C1927	10K
Q110	2SB709A	C1928	10K
Q111	2SB709A	C1929	10K
Q112	2SB709A	C1930	10K
Q113	2SB709A	C1931	10K
Q114	2SB709A	C1932	10K
Q115	2SB709A	C1933	10K
Q116	2SB709A	C1934	10K
Q117	2SB709A	C1935	10K
Q118	2SB709A	C1936	10K
Q119	2SB709A	C1937	10K
Q120	2SB709A	C1938	10K
Q121	2SB709A	C1939	10K
Q122	2SB709A	C1940	10K
Q123	2SB709A	C1941	10K
Q124	2SB709A	C1942	10K
Q125	2SB709A	C1943	10K
Q126	2SB709A	C1944	10K
Q127	2SB709A	C1945	10K
Q128	2SB709A	C1946	10K
Q129	2SB709A	C1947	10K
Q130	2SB709A	C1948	10K
Q131	2SB709A	C1949	10K
Q132	2SB709A	C1950	10K
Q133	2SB709A	C1951	10K
Q134	2SB709A	C1952	10K
Q135	2SB709A	C1953	10K
Q136	2SB709A	C1954	10K
Q137	2SB709A	C1955	10K
Q138	2SB709A	C1956	10K
Q139	2SB709A	C1957	10K
Q140	2SB709A	C1958	10K
Q141	2SB709A	C1959	10K
Q142	2SB709A	C1960	10K
Q143	2SB709A	C1961	10K
Q144	2SB709A	C1962	10K
Q145	2SB709A	C1963	10K
Q146	2SB709A	C1964	10K
Q147	2SB709A	C1965	10K
Q148	2SB709A	C1966	10K
Q149	2SB709A	C1967	10K
Q150	2SB709A	C1968	10K
Q151	2SB709A	C1969	10K
Q152	2SB709A	C1970	10K
Q153	2SB709A	C1971	10K
Q154	2SB709A	C1972	10K
Q155	2SB709A	C1973	10K
Q156	2SB709A	C1974	10K
Q157	2SB709A	C1975	10K
Q158	2SB709A	C1976	10K
Q159	2SB709A	C1977	10K
Q160	2SB709A	C1978	10K
Q161	2SB709A	C1979	10K
Q162	2SB709A	C1980	10K
Q163	2SB709A	C1981	10K
Q164	2SB709A	C1982	10K
Q165	2SB709A	C1983	10K
Q166	2SB709A	C1984	10K
Q167	2SB709A	C1985	10K
Q168	2SB709A	C1986	10K
Q169	2SB709A	C1987	10K
Q170	2SB709A	C1988	10K
Q171	2SB709A	C1989	10K
Q172	2SB709A	C1990	10K
Q173	2SB709A	C1991	10K
Q174	2SB709A	C1992	10K
Q175	2SB709A	C1993	10K
Q176	2SB709A	C1994	10K
Q177	2SB709A	C1995	10K
Q178	2SB709A	C1996	10K
Q179	2SB709A	C1997	10K
Q180	2SB709A	C1998	10K
Q181	2SB709A	C1999	10K
Q182	2SB709A	C2000	10K
Q183	2SB709A	C2001	10K
Q184	2SB709A	C2002	10K
Q185	2SB709A	C2003	10K
Q186	2SB709A	C2004	10K
Q187	2SB709A	C2005	10K
Q188	2SB709A	C2006	10K
Q189	2SB709A	C2007	10K
Q190	2SB709A	C2008	10K
Q191	2SB709A	C2009	10K
Q192	2SB709A	C2010	10K
Q193	2SB709A	C2011	10K
Q194	2SB709A	C2012	10K
Q195	2SB709A	C2013	10K
Q196	2SB709A	C2014	10K
Q197	2SB709A	C2015	10K
Q198	2SB709A	C2016	10K
Q199	2SB709A	C2017	10K
Q200	2SB709A	C2018	10K
Q201	2SB709A	C2019	10K
Q202	2SB709A	C2020	10K
Q203	2SB709A	C2021	10K
Q204	2SB709A	C2022	10K
Q205	2SB709A	C2023	10K
Q206	2SB709A	C2024	10K
Q207	2SB709A	C2025	10K
Q208	2SB709A	C2026	10K
Q209	2SB709A	C2027	10K
Q210	2SB709A	C2028	10K
Q211	2SB709A	C2029	10K
Q212	2SB709A	C2030	10K
Q213	2SB709A	C2031	10K
Q214	2SB709A	C2032	10K
Q215	2SB709A	C2033	10K
Q216	2SB709A	C2034	10K
Q217	2SB709A	C2035	10K
Q218	2SB709A	C2036	10K
Q219	2SB709A	C2037	10K
Q220	2SB709A	C2038	10K
Q221	2SB709A	C2039	10K
Q222	2SB709A	C2040	10K
Q223	2SB709A	C2041	10K
Q224	2SB709A	C2042	10K
Q225	2SB709A	C2043	10K
Q226	2SB709A	C2044	10K
Q227	2SB709A	C2045	10K
Q228	2SB709A	C2046	10K
Q229	2SB709A	C2047	10K
Q230	2SB709A	C2048	10K
Q231	2SB709A	C2049	10K
Q232	2SB709A	C2050	10K
Q233	2SB709A	C2051	10K
Q234	2SB709A	C2052	10K
Q235	2SB709A	C2053	10K
Q236	2SB709A	C2054	10K
Q237	2SB709A	C2055	10K
Q238	2SB709A	C2056	10K
Q239	2SB709A	C2057	10K
Q240	2SB709A	C2058	10K
Q241	2SB709A	C2059	10K
Q242	2SB709A	C2060	10K
Q243	2SB709A	C2061	10K
Q244	2SB709A	C2062	10K
Q245	2SB709A	C2063	10K
Q246	2SB709A	C2064	10K
Q247	2SB709A	C2065	10K
Q248	2SB709A	C2066	10K
Q249	2SB709A	C2067	10K
Q250	2SB709A	C2068	10K
Q251	2SB709A	C2069	10K
Q252	2SB709A	C2070	10K
Q253	2SB709A	C2071	10K
Q254	2SB709A	C2072	10K
Q255	2SB709A	C2073	10K
Q256	2SB709A	C2074	10K
Q257	2SB709A	C2075	10K
Q258	2SB709A	C2076	10K
Q259	2SB709A	C2077	10K
Q260	2SB709A	C2078	10K
Q261	2SB709A	C2079	10K
Q262	2SB709A	C2080	10K
Q263	2SB709A	C2081	10K
Q264	2SB709A	C2082	10K
Q265	2SB709A	C2083	10K
Q266	2SB709A	C2084	10K
Q267	2SB709A	C2085	10K
Q268	2SB709A	C2086	10K
Q269	2SB709A	C2087	10K
Q270	2SB709A	C2088	10K
Q271	2SB709A	C2089	10K
Q272	2SB709A	C2090	10K
Q273	2SB709A	C2091	10K
Q274	2SB709A	C2092	10K
Q275	2SB709A	C2093	10K
Q276	2SB709A	C2094	10K
Q277	2SB709A	C2095	10K
Q278	2SB709A	C2096	10K
Q279	2SB709A	C2097	10K
Q280	2SB709A	C2098	10K
Q281	2SB709A	C2099	10K
Q282	2SB709A	C2100	10K
Q283	2SB709A	C2101	10K
Q284	2SB709A	C2102	10K
Q285	2SB709A	C2103	10K
Q286	2SB709A	C2104	10K
Q287	2SB709A	C2105	10K
Q288	2SB709A	C2106	10K
Q289	2SB709A	C2107	10K
Q290	2SB709A	C2108	10K
Q291	2SB709A	C2109	10K
Q292	2SB709A	C2110	10K
Q293	2SB709A	C2111	10K
Q294	2SB709A	C2112	10K
Q295	2SB709A	C2113	10K
Q296	2SB709A	C2114	10K
Q297	2SB709A	C2115	10K
Q298	2SB709A	C2116	10K
Q299	2SB709A	C2117	10K
Q300	2SB709A	C2118	10K
Q301	2SB709A	C2119	10K
Q302	2SB709A	C2120	10K
Q303	2SB709A	C2121	10K
Q304	2SB709A	C2122	10K
Q305	2SB709A	C2123	10K
Q306	2SB709A	C2124	10K
Q307	2SB709A	C2125	10K
Q308	2SB709A	C2126	10K
Q309	2SB709A	C2127	10K
Q310	2SB709A	C2128	10K
Q311	2SB709A	C2129	10K
Q312	2SB709A	C2130	10K
Q313	2SB709A	C2131	10K
Q314	2SB709A	C2132	10K
Q315	2SB709A	C2133	10K
Q316	2SB709A	C2134	10K
Q317	2SB709A	C2135	10K
Q318	2SB709A	C2136	10K
Q319	2SB709A	C2137	10K
Q320	2SB709A	C2138	10K
Q321	2SB709A	C2139	10K
Q322	2SB709A	C2140	10K
Q323	2SB709A	C2141	10K
Q324	2SB709A	C2142	10K
Q325	2SB709A	C2143	10K
Q326	2SB709A	C2144	10K
Q327	2SB709A	C2145	10K
Q328	2SB709A	C2146	10K
Q329	2SB709A	C2147	10K
Q330	2SB709A	C2148	10K
Q331	2SB709A	C2149	10K
Q332	2SB709A	C2150	10K
Q333	2SB709A	C2151	10K
Q334	2SB709A	C2152	10K
Q335	2SB709A	C2153	10K
Q336	2SB709A	C2154	10K
Q337	2SB709A	C2155	10K
Q338	2SB709A	C2156	10K
Q339	2SB709A	C2157	10K
Q340	2SB709A	C2158	10K
Q341	2SB709A	C2159	10K
Q342	2SB709A	C2160	10K
Q343	2SB709A	C2161	10K
Q344	2SB709A	C2162	10K
Q345	2SB709A	C2163	10K
Q346	2SB709A	C2164	10K
Q347	2SB709A	C2165	10K
Q348	2SB709A	C2166	

- AV BOARD - (EXCEPT KV-27V20/29V20M)

**AV**

[SUB TUNER, D/A CONV.]

**K**

[AUDIO AMP]

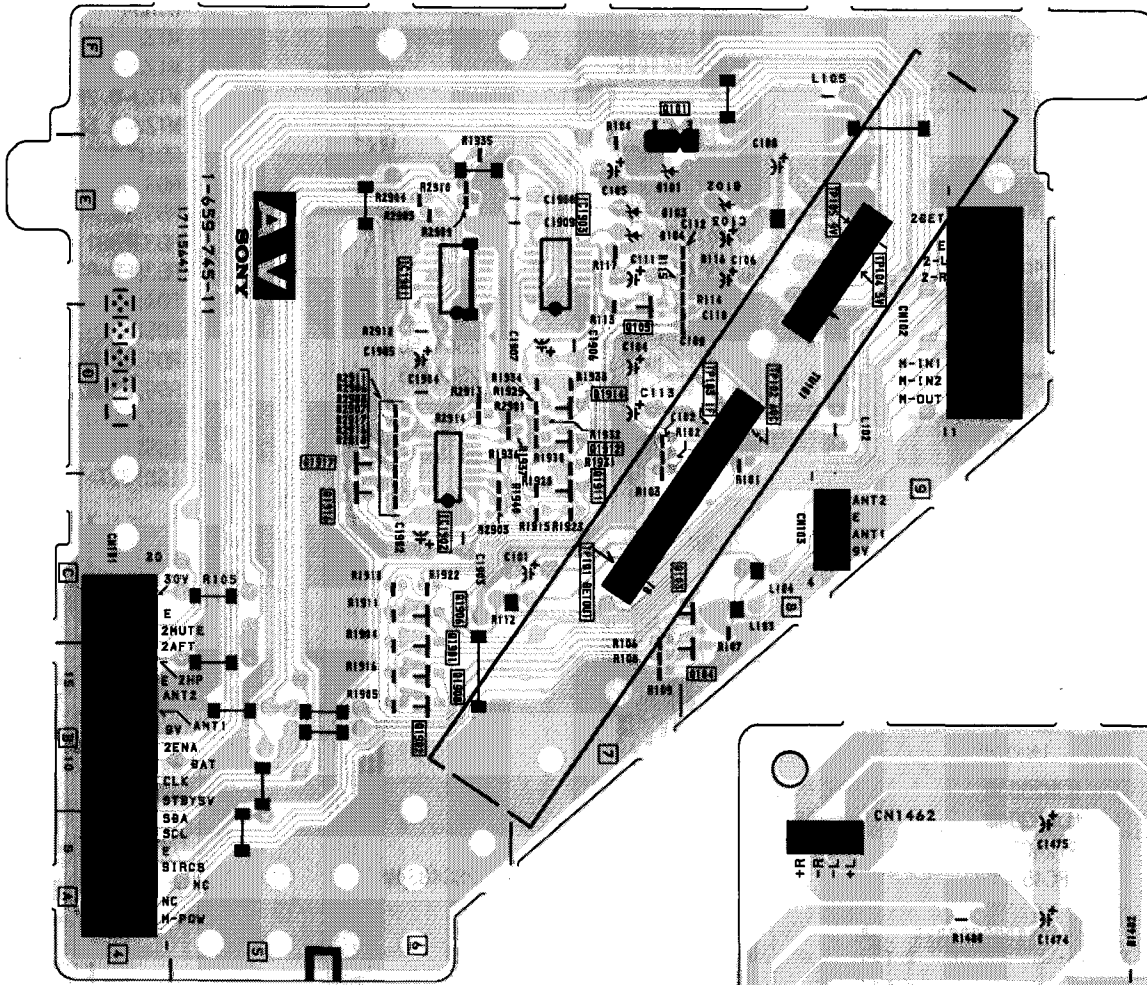

- K BOARD -

(KV-27V35/29V35C/29V75M/32V35/34V35C ONLY)

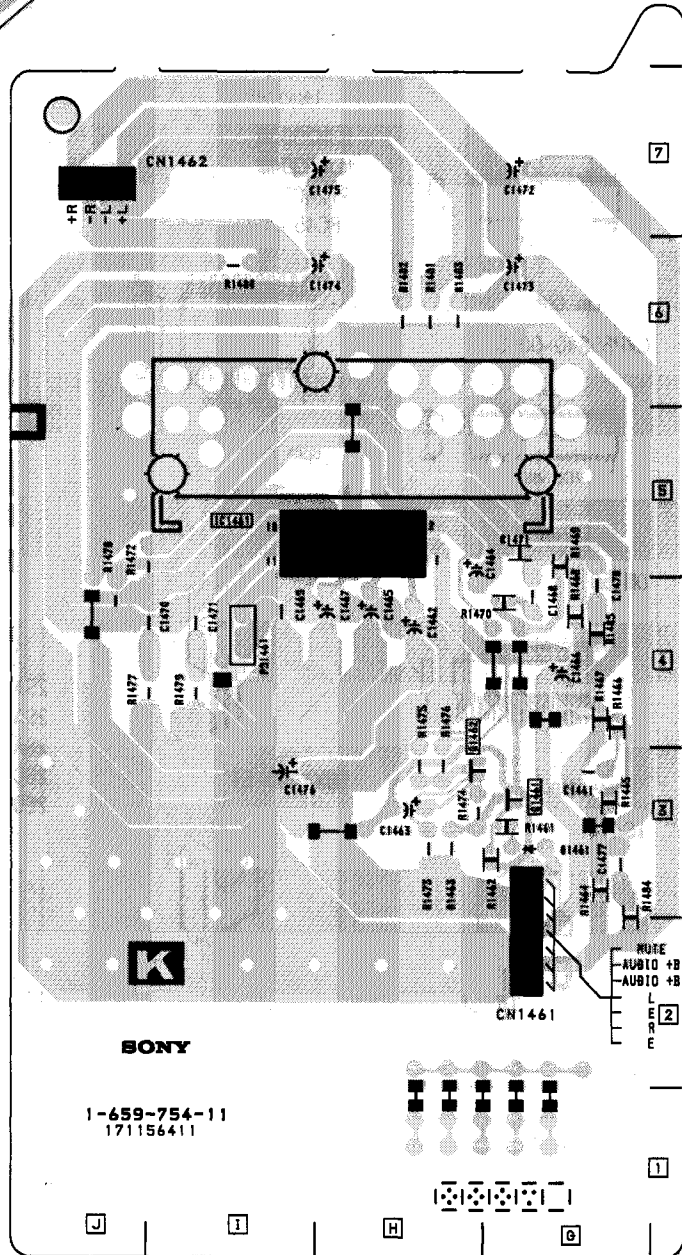

# 4-4. SEMICONDUCTORS

BH3856FS-E2

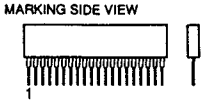

32pin SIP

CD4052BCN

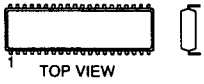

16pin DIP

CXA1315M

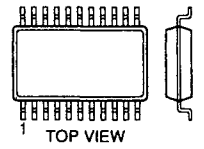

16pin SOP

CXA2025S

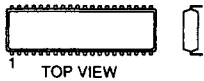

48pin DIP

CXP85640-005S



64pin DIP

DM-58

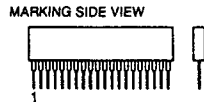

4pin SIP

IS474

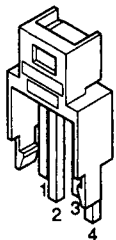

LM2901M  
NJM2902M-TE2

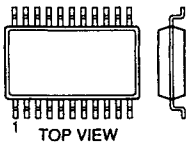

14pin SOP

MM1313AD

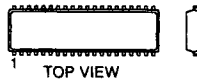

42pin DIP

NJM2129M-TE2

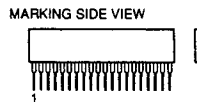

14pin SIP

NJM2903M  
NJM2904M  
ST24C02FM6TR  
UPC4558G2

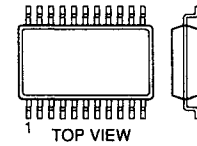

8pin SOP

NJM78M05FA  
TA7805S

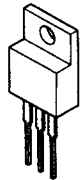

SBX1790-51



SDA9288X

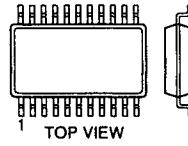

32pin SOP

SI3090CA

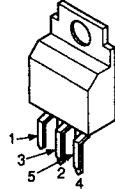

TDA2009A

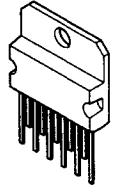

TDA8172

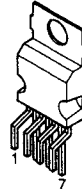

TDA8315T/N3A-T

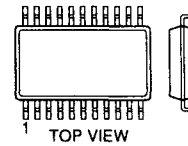

24pin SOP

2SA1037AK-T146-R  
2SA1162-G  
2SA1330-06  
2SC1623-L5L6  
2SD601A-Q

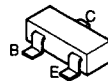

2SA1091-0



2SA1175-HFE  
2SC2785-HFE

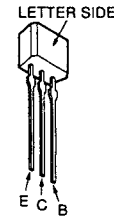

2SA1837  
2SC4159-E  
2SC4793



2SC2611

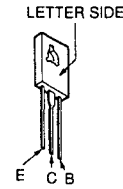

2SC4834M



2SC4927-01

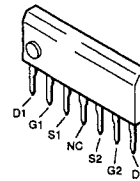

2SD774-34

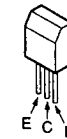

D10SC4M



D1NS4  
MTZJ-3.3  
MTZJ-33A  
MTZJ-6.2B  
MTZJ-7.5B  
RD10ESB2  
RD3.3ES-B2  
RD3.9ES-B2  
RD33ESB1  
RD39ES-B2  
RD4.3ES-B3  
RD5.6ESB2  
RD5.6ESB3  
RD6.2ESB2  
RD7.5ESB2  
1SS119-25  
1SS133T-77

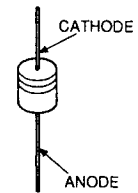

D2L20U  
EGP20G  
EL1Z  
EZ0150AV1  
GP08D  
MTZJ-T-77-3.9  
MTZJ-T-77-4.3C

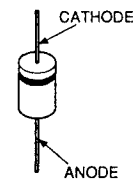

D4SB60L  
RBA-1004B

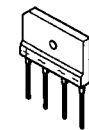

ERC06-15S

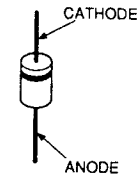

ERD29-08J

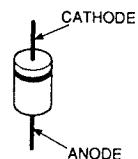

# SECTION 5 EXPLODED VIEWS

**NOTE:**

- Items with no part number and no description are not stocked because they are seldom required for routine service.
- The construction parts of an assembled part are indicated with a collation number in the remark column.

- Items marked " \* " are not stocked since they are seldom required for routine service. Some delay should be anticipated when ordering these items.

The components identified by shading and mark  $\Delta$  are critical for safety. Replace only with part number specified.

Les composants identifiés par une trame et une marque  $\Delta$  sont critiques pour la sécurité. Ne les remplacer que par une pièce portant le numéro spécifié.

**5-1. CHASSIS (EXCEPT KV-32V25/32V35/34V35C)**

- : 7-685-648-79 +BVTP 3X12
- : 7-685-663-79 +BVTP 4X16

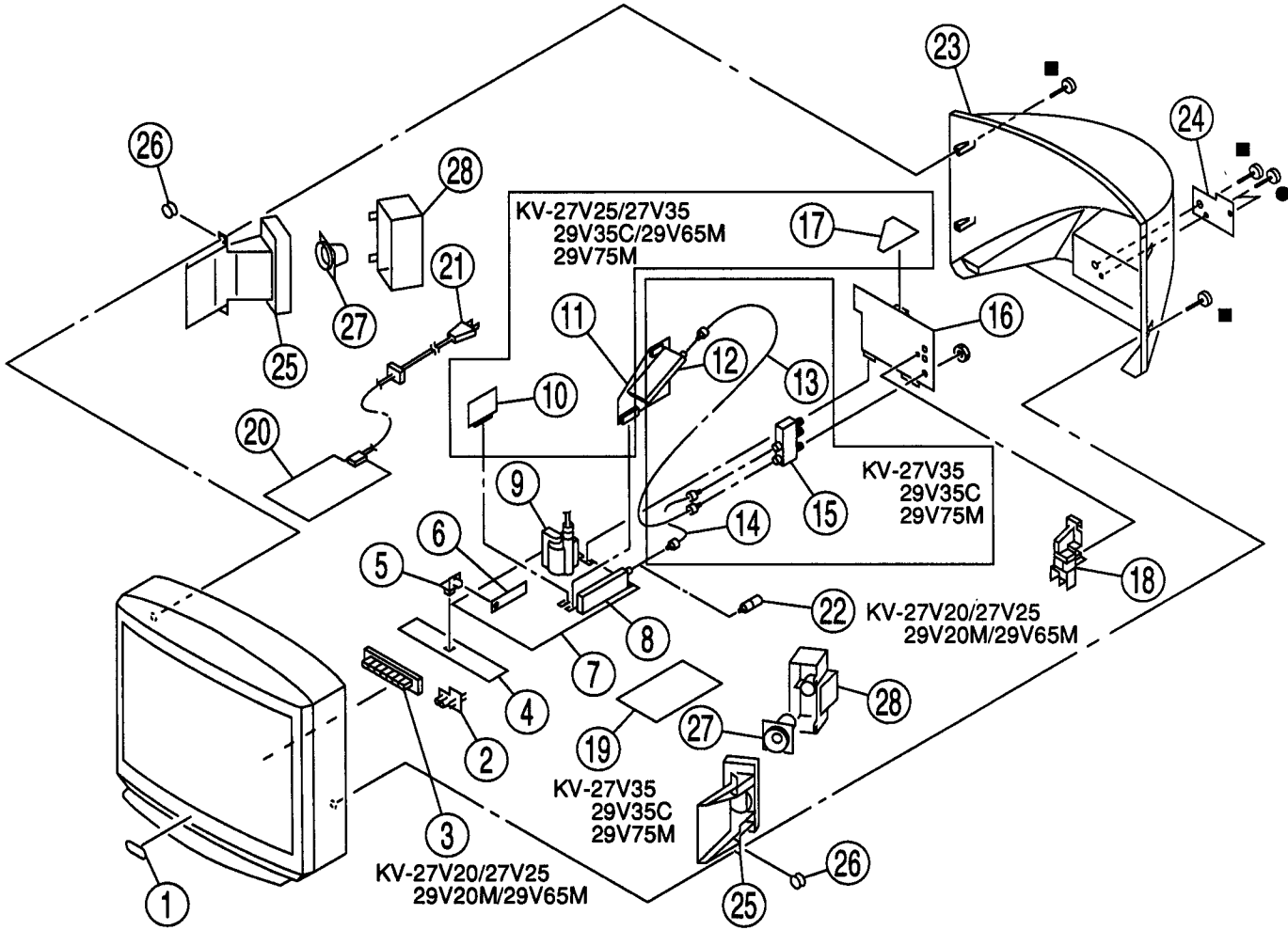

REF. NO.	PART NO.	DESCRIPTION	REMARK
1	4-046-160-01	EMBLEM (NO.9), SONY	
2	* 4-052-897-01	GUIDE, LED	
3	4-052-907-01	BUTTON, MULTI (27V20/27V25/29V20M/29V65M)	
4	* A-1372-233-A	HV BOARD, COMPLETE (27V20/27V25/29V20M/29V65M)	
	* A-1372-234-A	HV BOARD, COMPLETE (27V35/29V35C/29V75M)	
5	* 3-696-606-02	HINGE, VI	
6	* 1-659-757-11	SA BOARD	
7	* A-1297-806-A	A BOARD, COMPLETE (27V20/29V20M)	
	* A-1297-807-A	A BOARD, COMPLETE (27V35/29V35C/29V75M)	
	* A-1297-851-A	A BOARD, COMPLETE (27V25/29V65M)	
8	△ 8-598-340-00	TUNER BTF-WA404	
9	△ 1-453-207-11	TRANSFORMER ASSY, FLYBACK (NX-2609/IX4C)	
10	* A-1195-103-A	P BOARD, COMPLETE (27V25/27V35/29V35C/29V65M/29V75M)	
11	* A-1297-720-A	AV BOARD, COMPLETE (27V35/29V35C/29V75M)	
	* A-1297-850-A	AV BOARD, COMPLETE (27V25/29V65M)	
12	△ 8-598-339-00	TUNER BTF-LA402 (27V35/29V35C/29V75M)	
13	* 1-557-056-31	CABLE, P-P (27V35/29V35C/29V75M)	
14	* 1-556-945-21	CABLE, P-P (27V35/29V35C/29V75M)	
15	8-598-358-00	CHANGER, ANTENNA AS-2K (27V35/29V35C/29V75M)	
16	* A-1394-756-A	UV BOARD, COMPLETE (27V20/29V20M)	
	* A-1394-757-A	UV BOARD, COMPLETE (27V35/29V35C/29V75M)	
	* A-1394-772-A	U BOARD, COMPLETE (27V25/29V65M)	
17	* A-1390-585-A	SC BOARD, COMPLETE (27V25/27V35/29V35C/29V65M/29V75M)	
18	* 4-052-905-01	BRACKET, V5/6	
19	* A-1380-518-A	K BOARD, COMPLETE (27V35/29V35C/29V75M)	
20	* A-1316-252-A	G BOARD, COMPLETE (29V35C)	
	* A-1316-261-A	G BOARD, COMPLETE (except KV-29V35C)	
21	△ 1-751-059-11	CORD, POWER (WITH CONNECTOR) 10A/125V (except KV-29V35C)	
	△ 1-769-796-21	CORD, POWER (WITH CONNECTOR) (29V35C)	
22	1-766-374-11	PLUG, F-PIN (27V20/27V25/29V20M/29V65M)	
23	X-4033-615-2	COVER ASSY, REAR (27V20/27V25/29V20M/29V65M)	
	X-4033-618-1	COVER ASSY, REAR (27V35/29V35C/29V75M)	
24	4-052-898-01	LABEL, TERMINAL (27V35/29V35C/29V75M)	
	4-052-899-01	LABEL, TERMINAL (27V25/29V65M)	
	4-053-783-01	LABEL, TERMINAL (27V20/29V20M)	
25	4-043-457-11	BAFFLE, SPEAKER	
26	4-374-745-31	CUSHION (A)	
27	1-504-524-11	SPEAKER (8CM) (27V20/27V25/29V20M/29V65M)	
	1-505-326-11	SPEAKER (8CM) (27V35/29V35C/29V75M)	
28	X-4032-226-1	COVER ASSY, SPEAKER (27V20/27V25/29V20M/29V65M)	
	X-4033-616-1	COVER ASSY, SPEAKER (27V35/29V35C/29V75M)	

The components identified by shading and mark △ are critical for safety. Replace only with part number specified.

Les composants identifiés par une trame et une marque △ sont critiques pour la sécurité. Ne les remplacer que par une pièce portant le numéro spécifié.

## 5-2. PICTURE TUBE (EXCEPT KV-32V25/32V35/34V35C)

● : 7-685-648-79 +BVTP 3X12

The components identified by shading and mark  $\Delta$  are critical for safety. Replace only with part number specified.

Les composants identifiés par une trame et une marque  $\Delta$  sont critiques pour la sécurité. Ne les remplacer que par une pièce portant le numéro spécifié.

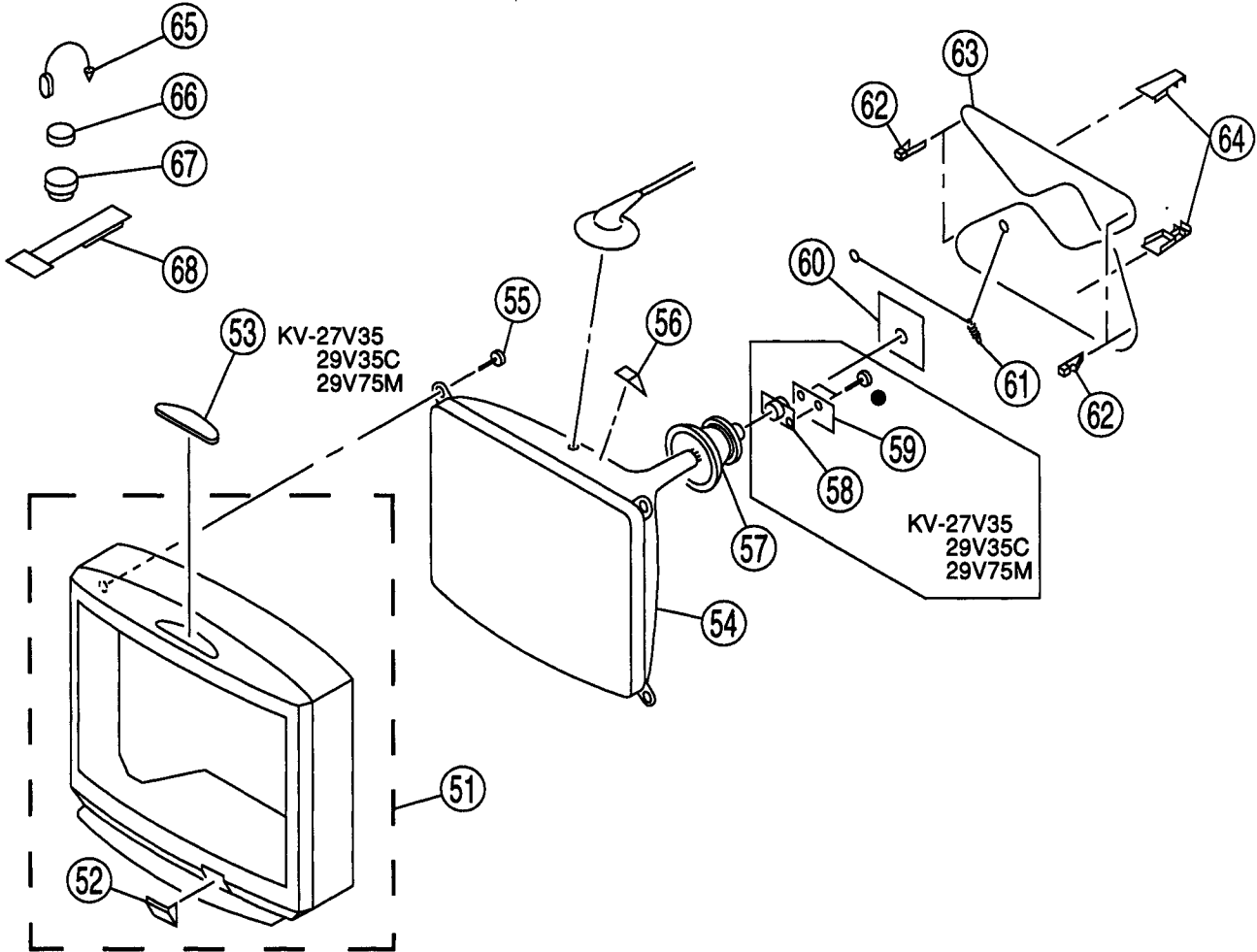

REF. NO.	PART NO.	DESCRIPTION	REMARK	REF. NO.	PART NO.	DESCRIPTION	REMARK
51	X-4033-614-2	BEZNET ASSY (27V20/29V20M)	52	58	$\Delta$ 1-452-509-42	NECK ASSY, PICTURE TUBE (NA-308)	(27V35/29V35C/29V75M)
	X-4033-617-1	BEZNET ASSY (27V35/29V35C/29V75M)	52	59	* A-1372-225-A	WB BOARD, COMPLETE	(27V35/29V35C/29V75M)
	X-4033-623-2	BEZNET ASSY (27V25/29V65M)	52	60	* A-1331-549-A	C BOARD, COMPLETE	(27V35/29V35C/29V75M)
52	4-052-906-01	DOOR, CONTROL		61	4-036-329-01	SPRING (B), TENSION	
53	1-473-549-11	SWITCH BLOCK, CONTROL (27V35/29V35C/29V75M)		62	4-040-388-01	HOLDER (S), DGC	
54	$\Delta$ 8-733-848-05	PICTURE TUBE 29PXD (A68KZ150X) (except 29V35C)		63	$\Delta$ 1-406-726-13	COIL, DEGAUSSING	
	$\Delta$ 8-733-849-05	PICTURE TUBE 29PXD (A68KZ150X) (29V35C)		64	4-040-387-01	HOLDER (M), DGC	
55	4-041-268-01	SCREW (7), TAPPING		65	4-308-870-00	CLIP, LEAD WIRE	
56	4-053-005-01	SPACER, DEFLECTION YOKE		66	1-452-032-00	MAGNET, DISC ; 10MM $\phi$	
57	$\Delta$ 8-451-275-42	DEFLECTION YOKE Y28PFA		67	1-452-094-00	MAGNET, ROTATABLE DISK ; 15MM $\phi$	
				68	4-051-737-21	PIECE A(100), CONV. CORRECT	

### 5-3. CHASSIS (KV-32V25/32V35/34V35C)

■ : 7-685-663-79 +BVTP 4X16

The components identified by shading and mark  $\Delta$  are critical for safety. Replace only with part number specified.

Les composants identifiés par une trame et une marque  $\Delta$  sont critiques pour la sécurité. Ne les remplacer que par une pièce portant le numéro spécifié.

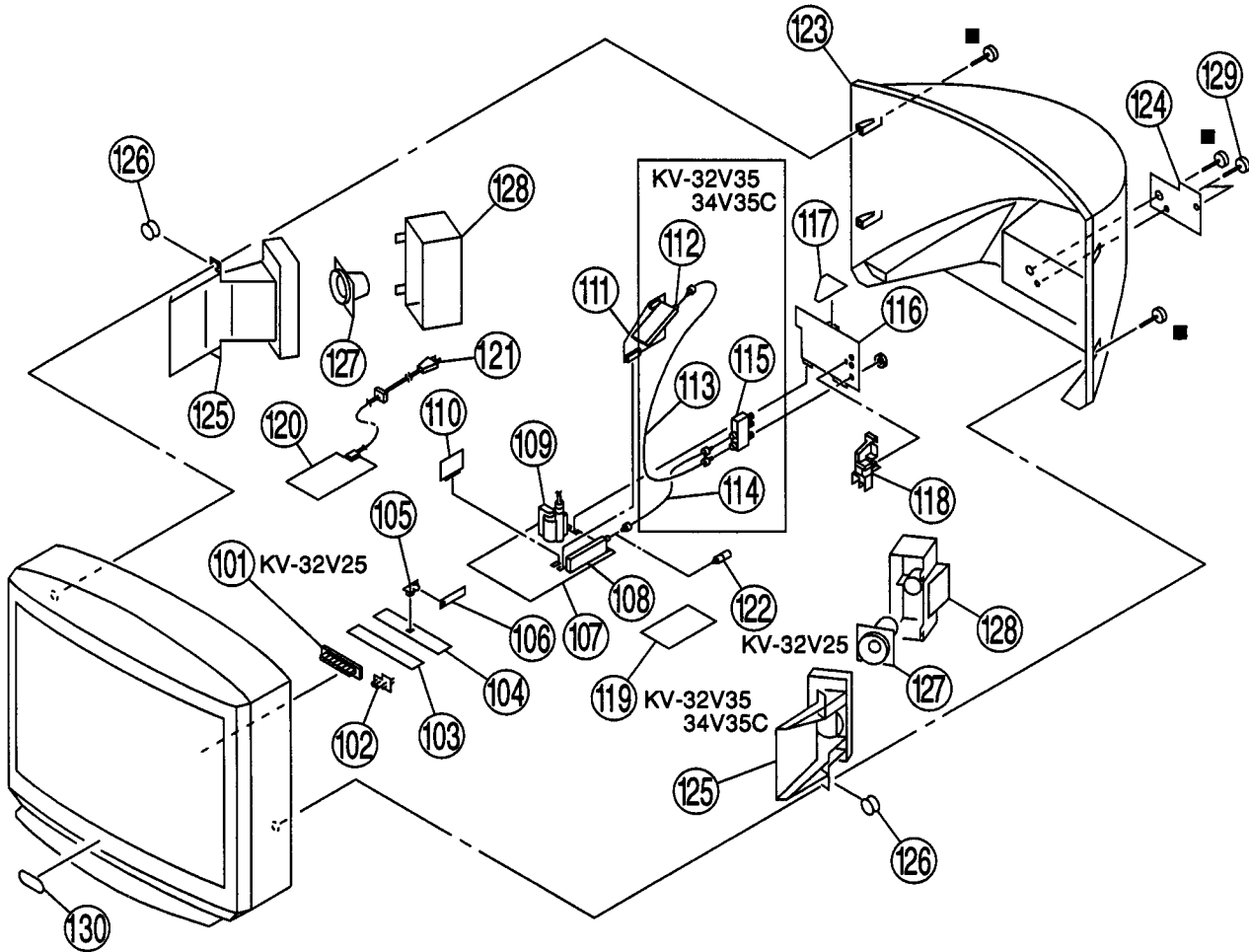

REF. NO.	PART NO.	DESCRIPTION	REMARK	REF. NO.	PART NO.	DESCRIPTION	REMARK
101	4-052-907-01	BUTTON, MULTI (32V25)		117	* A-1390-585-A	SC BOARD, COMPLETE	
102	* 4-052-897-01	GUIDE, LED		118	* 4-052-905-01	BRACKET, V5/6	
103	* A-1372-207-A	HV BOARD, COMPLETE (32V25 (US))		119	* A-1380-518-A	K BOARD, COMPLETE (32V35/34V35C)	
	* A-1372-212-A	HV BOARD, COMPLETE		120	* A-1316-252-A	G BOARD, COMPLETE (34V35C)	
		(except KV-32V25 (US))			* A-1316-261-A	G BOARD, COMPLETE (32V25/32V35)	
104	* A-1372-209-A	HS BOARD, COMPLETE		121	$\Delta$ 1-751-039-11	CORD, POWER (WITH CONNECTOR)	
105	* 3-696-606-02	HINGE, VI				10A/125V (32V25/32V35)	
106	* 1-659-757-11	SA BOARD			$\Delta$ 1-769-796-21	CORD, POWER (WITH CONNECTOR)	(34V35C)
107	* A-1297-812-A	A BOARD, COMPLETE (32V35/34V35C)		122	1-766-374-11	PLUG, F-PIN (32V25)	
	* A-1297-862-A	A BOARD, COMPLETE (32V25)		123	4-053-766-01	COVER, REAR (32V35/34V35C)	
108	$\Delta$ 8-598-340-00	TUNER BIT-WA404			4-053-766-11	COVER, REAR (32V25)	
109	$\Delta$ 1-453-207-11	TRANSFORMER ASSY, FLYBACK	(EX-2609/1X4C)	124	4-052-898-01	LABEL, TERMINAL (32V35/34V35C)	
110	* A-1195-103-A	P BOARD, COMPLETE			4-052-899-01	LABEL, TERMINAL (32V25)	
111	* A-1297-720-A	AV BOARD, COMPLETE (32V35/34V35C)		125	4-043-457-11	BAFFLE, SPEAKER	
	* A-1297-850-A	AV BOARD, COMPLETE (32V25)		126	4-374-745-31	CUSHION (A)	
112	$\Delta$ 8-598-339-00	TUNER BIT-LA402 (32V35/34V35C)		127	1-504-524-11	SPEAKER (8CM) (32V25)	
113	* 1-557-056-31	CABLE, P-P (32V35/34V35C)			1-505-326-11	SPEAKER (8CM) (32V35/34V35C)	
114	* 1-556-945-21	CABLE, P-P (32V35/34V35C)		128	X-4032-226-1	COVER ASSY, SPEAKER (32V25)	
115	8-598-358-00	CHANGER, ANTENNA AS-2K (32V35/34V35C)			X-4033-616-1	COVER ASSY, SPEAKER (32V35/34V35C)	
116	* A-1394-720-A	UV BOARD, COMPLETE (32V35/34V35C)		129	4-041-165-01	SCREW (3X12), TAPPING, +BV	
	* A-1394-778-A	UV BOARD, COMPLETE (32V25)		130	4-046-160-01	EMBLEM (NO.9), SONY	

### 5-4. PICTURE TUBE (KV-32V25/32V35/34V35C)

The components identified by shading and mark  $\Delta$  are critical for safety. Replace only with part number specified.

Les composants identifiés par une trame et une marque  $\Delta$  sont critiques pour la sécurité. Ne les remplacer que par une pièce portant le numéro spécifié.

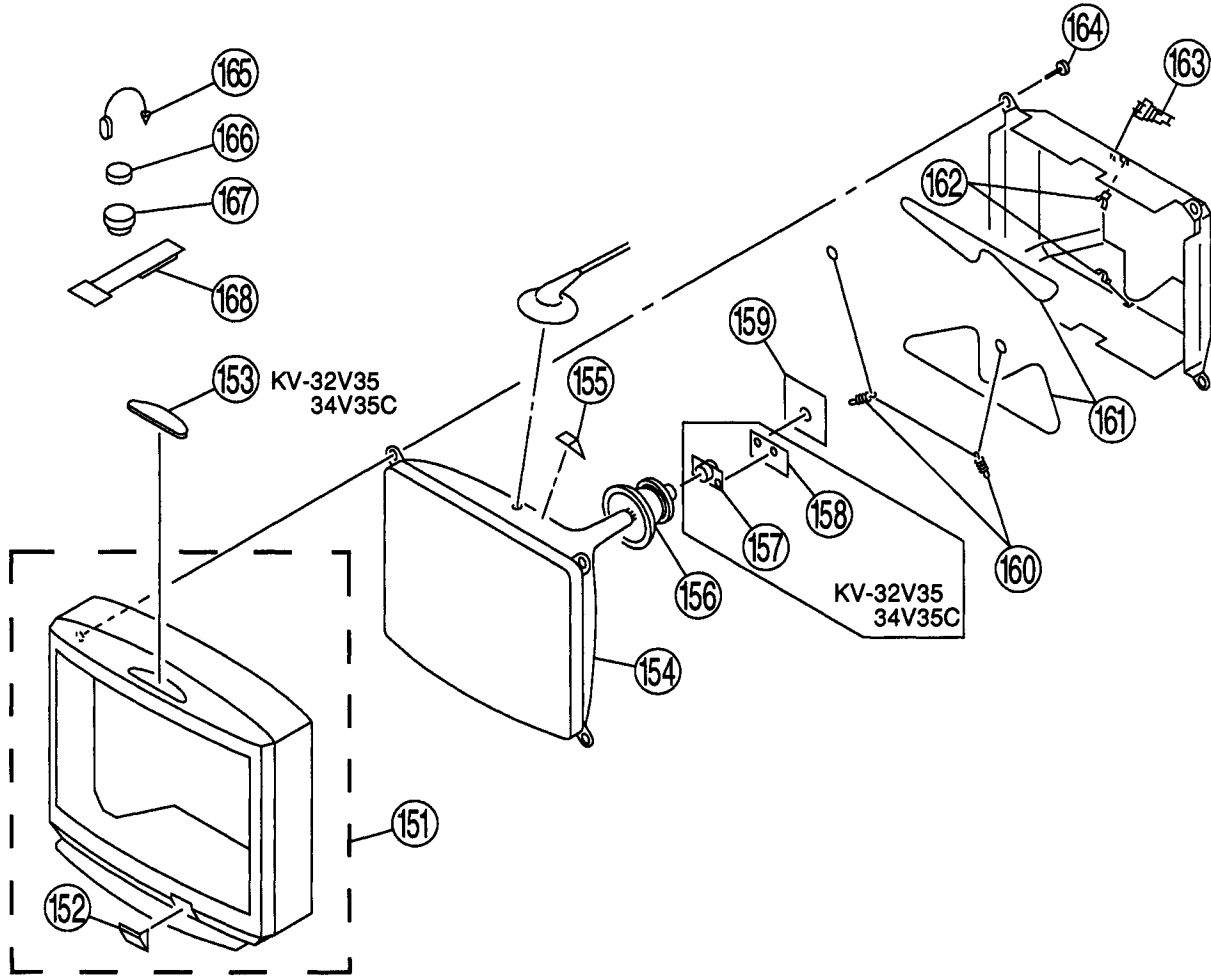

REF. NO.	PART NO.	DESCRIPTION	REMARK	REF. NO.	PART NO.	DESCRIPTION	REMARK
151	X-4033-669-1	BEZNET ASSY (32V35/34V35C)	152	158	* A-1372-225-A	WB BOARD, COMPLETE (32V35/34V35C)	
	X-4033-670-1	BEZNET ASSY (32V25)	152	159	* A-1331-549-A	C BOARD, COMPLETE	
152	4-052-906-01	DOOR, CONTROL (32V25)		160	4-036-329-01	SPRING (B), TENSION	
	4-052-906-11	DOOR, CONTROL (32V35/34V35C)		161	$\Delta$ 1-402-952-12	COIL, DEMAGNETIZATION (32V25/32V35)	
153	1-473-549-11	SWITCH BLOCK, CONTROL (32V35/34V35C)			$\Delta$ 1-411-474-11	COIL, DEMAGNETIZATION (34V35C)	
154	$\Delta$ 8-733-742-05	PICTURE TUBE 34FXD2 (M80JYV51X)		162	* 4-371-629-01	STOPPER, WIRE	
		(34V35C)		163	4-033-681-01	HOLDER, LEAD	
	$\Delta$ 8-733-743-05	PICTURE TUBE 34FXD2 (M80JYV51X)		164	4-041-268-01	SCREW (7), TAPPING	
		(32V25/32V35)		165	4-308-870-00	CLIP, LEAD WIRE	
155	4-041-361-01	SPACER, DEFLECTION YOKE (34V35C)		166	1-452-032-00	MAGNET, DISC ; 10MM $\phi$	
	4-053-005-01	SPACER, DEFLECTION YOKE (32V25/32V35)		167	1-452-094-00	MAGNET, ROTATABLE DISK ; 15MM $\phi$	
156	$\Delta$ 8-451-452-11	DEFLECTION YOKE Y34FXA2-V		168	4-051-737-21	PIECE A (100), CONV. CORRECT	
157	$\Delta$ 1-452-579-21	NECK ASSY, PICTURE TUBE (NA322)					
		(32V35/34V35C)					

## SECTION 6

# ELECTRICAL PARTS LIST

P

NOTE:

Les composants identifiés par une trame et une marque  $\Delta$  sont critiques pour la sécurité. Ne les remplacer que par une pièce portant le numéro spécifié.

The components identified by shading and mark  $\Delta$  are critical for safety. Replace only with part number specified.

- The components identified by  $\square$  in this manual have been carefully factory-selected for each set in order to satisfy regulations regarding X-ray radiation. Should replacement be required, replace only with the value originally used.

- Items marked " \* " are not stocked since they are seldom required for routine service. Some delay should be anticipated when ordering these items.

- All variable and adjustable resistors have characteristic curve B, unless otherwise noted.

### RESISTORS

- All resistors are in ohms
- F : nonflammable

When indicating parts by reference number, please include the board name.

• CAPACITORS  
PF :  $\mu\mu$  F

• There are some cases the reference number on one board overlaps on the other board. Therefore, when ordering parts by the reference number, please include the board name.

REF. NO.	PART NO.	DESCRIPTION	REMARK	REF. NO.	PART NO.	DESCRIPTION	REMARK
* A-1195-103-A P BOARD, COMPLETE ***** (except 27V20/29V20M)				<COIL>			
		<CAPACITOR>		L3301	1-408-413-00	INDUCTOR 22UH	
				L3302	1-410-473-11	INDUCTOR 18UH	
				L3303	1-408-418-00	INDUCTOR 56UH	
C3301	1-163-017-00	CERAMIC CHIP 0.0047MF 10%	50V	<TRANSISTOR>			
C3302	1-164-346-11	CERAMIC CHIP 1MF	16V	Q3301	8-729-422-27	TRANSISTOR 2SD601A-Q	
C3303	1-163-038-91	CERAMIC CHIP 0.1MF	25V	Q3305	8-729-216-22	TRANSISTOR 2SA1162-G	
C3304	1-124-903-11	ELECT 1MF 20%	50V	Q3306	8-729-216-22	TRANSISTOR 2SA1162-G	
C3305	1-163-038-91	CERAMIC CHIP 0.1MF	25V	Q3307	8-729-216-22	TRANSISTOR 2SA1162-G	
C3306	1-126-967-11	ELECT 47MF 20%	16V	Q3308	8-729-422-27	TRANSISTOR 2SD601A-Q	
C3307	1-163-038-91	CERAMIC CHIP 0.1MF	25V	Q3310	8-729-422-27	TRANSISTOR 2SD601A-Q	
C3308	1-163-231-11	CERAMIC CHIP 15PF 5%	50V	Q3312	8-729-216-22	TRANSISTOR 2SA1162-G	
C3309	1-163-017-00	CERAMIC CHIP 0.0047MF 10%	50V	Q3313	8-729-422-27	TRANSISTOR 2SD601A-Q	
C3310	1-164-004-11	CERAMIC CHIP 0.1MF 10%	25V	<RESISTOR>			
C3313	1-163-038-91	CERAMIC CHIP 0.1MF	25V	R3301	1-216-075-00	METAL GLAZE 12K 5%	1/10W
C3314	1-163-038-91	CERAMIC CHIP 0.1MF	25V	R3302	1-216-043-91	METAL GLAZE 560 5%	1/10W
C3315	1-164-346-11	CERAMIC CHIP 1MF	16V	R3303	1-216-295-91	CONDUCTOR, CHIP	
C3319	1-163-031-11	CERAMIC CHIP 0.01MF	50V	R3304	1-216-043-91	METAL GLAZE 560 5%	1/10W
C3320	1-124-903-11	ELECT 1MF 20%	50V	R3306	1-215-882-00	METAL OXIDE 22 5%	2W F
C3321	1-163-239-11	CERAMIC CHIP 33PF 5%	50V	R3307	1-216-097-91	METAL GLAZE 100K 5%	1/10W
C3322	1-163-239-11	CERAMIC CHIP 33PF 5%	50V	R3308	1-216-051-00	METAL GLAZE 1.2K 5%	1/10W
C3323	1-163-031-11	CERAMIC CHIP 0.01MF	50V	R3309	1-216-051-00	METAL GLAZE 1.2K 5%	1/10W
C3324	1-126-967-11	ELECT 47MF 20%	16V	R3310	1-216-689-11	METAL GLAZE 39K 5%	1/10W
C3325	1-163-038-91	CERAMIC CHIP 0.1MF	25V	R3311	1-216-689-11	METAL GLAZE 39K 5%	1/10W
C3326	1-163-038-91	CERAMIC CHIP 0.1MF	25V	R3312	1-216-037-00	METAL GLAZE 330 5%	1/10W
C3327	1-163-038-91	CERAMIC CHIP 0.1MF	25V	R3313	1-216-041-00	METAL GLAZE 470 5%	1/10W
C3328	1-126-967-11	ELECT 47MF 20%	16V	R3314	1-216-041-00	METAL GLAZE 470 5%	1/10W
C3329	1-126-967-11	ELECT 47MF 20%	16V	R3315	1-216-041-00	METAL GLAZE 470 5%	1/10W
C3330	1-163-031-11	CERAMIC CHIP 0.01MF	50V	R3316	1-216-053-00	METAL GLAZE 1.5K 5%	1/10W
C3331	1-126-967-11	ELECT 47MF 20%	16V	R3319	1-216-053-00	METAL GLAZE 1.5K 5%	1/10W
C3332	1-104-664-11	ELECT 47MF 20%	25V	R3321	1-216-053-00	METAL GLAZE 1.5K 5%	1/10W
C3333	1-164-695-11	CERAMIC CHIP 0.0022MF 5%	50V	R3322	1-216-065-00	METAL GLAZE 4.7K 5%	1/10W
C3334	1-163-031-11	CERAMIC CHIP 0.01MF	50V	R3323	1-216-065-00	METAL GLAZE 4.7K 5%	1/10W
C3335	1-163-038-91	CERAMIC CHIP 0.1MF	25V	R3324	1-216-065-00	METAL GLAZE 4.7K 5%	1/10W
C3336	1-163-038-91	CERAMIC CHIP 0.1MF	25V	R3326	1-216-037-00	METAL GLAZE 330 5%	1/10W
C3337	1-164-005-11	CERAMIC CHIP 0.47MF	25V	R3327	1-216-031-00	METAL GLAZE 180 5%	1/10W
C3338	1-163-141-00	CERAMIC CHIP 0.001MF 5%	50V	R3328	1-216-037-00	METAL GLAZE 330 5%	1/10W
C3340	1-163-031-11	CERAMIC CHIP 0.01MF	50V	R3329	1-216-069-00	METAL GLAZE 6.8K 5%	1/10W
C3346	1-163-251-11	CERAMIC CHIP 100PF 5%	50V	R3330	1-216-035-00	METAL GLAZE 270 5%	1/10W
C3347	1-124-903-11	ELECT 1MF 20%	50V	R3331	1-216-073-00	METAL GLAZE 10K 5%	1/10W
C3348	1-126-967-11	ELECT 47MF 20%	16V	R3332	1-216-041-00	METAL GLAZE 470 5%	1/10W
C3349	1-163-121-00	CERAMIC CHIP 150PF 5%	50V	R3337	1-216-033-00	METAL GLAZE 220 5%	1/10W
C3350	1-164-004-11	CERAMIC CHIP 0.1MF 10%	25V	R3338	1-216-033-00	METAL GLAZE 220 5%	1/10W
C3351	1-163-251-11	CERAMIC CHIP 100PF 5%	50V	R3339	1-216-041-00	METAL GLAZE 470 5%	1/10W
<CONNECTOR>				R3340	1-216-041-00	METAL GLAZE 470 5%	1/10W
CN3301	* 1-764-816-11	CONNECTOR, BOARD TO BOARD 20P		R3341	1-216-057-00	METAL GLAZE 2.2K 5%	1/10W
<IC>				R3342	1-216-057-00	METAL GLAZE 2.2K 5%	1/10W
IC3301	8-759-366-24	IC TDA8315T/N3A-T		R3343	1-216-049-91	METAL GLAZE 1K 5%	1/10W
IC3302	8-759-231-53	IC TA7805S		R3346	1-216-049-91	METAL GLAZE 1K 5%	1/10W
IC3303	8-759-361-12	IC SDA9288X					

REF. NO.	PART NO.	DESCRIPTION	REMARK
R3351	1-216-295-91	CONDUCTOR, CHIP	
R3352	1-216-049-91	METAL GLAZE 1K	5% 1/10W
R3358	1-216-047-91	METAL GLAZE 820	5% 1/10W
R3359	1-216-047-91	METAL GLAZE 820	5% 1/10W
R3360	1-216-053-00	METAL GLAZE 1.5K	5% 1/10W
R3361	1-216-053-00	METAL GLAZE 1.5K	5% 1/10W
R3362	1-216-029-00	METAL GLAZE 150	5% 1/10W
R3363	1-216-031-00	METAL GLAZE 180	5% 1/10W
R3364	1-216-035-00	METAL GLAZE 270	5% 1/10W
R3365	1-216-105-91	METAL GLAZE 220K	5% 1/10W
R3366	1-216-105-91	METAL GLAZE 220K	5% 1/10W
R3367	1-216-095-00	METAL GLAZE 82K	5% 1/10W
R3368	1-216-103-00	METAL GLAZE 180K	5% 1/10W
R3369	1-216-101-00	METAL GLAZE 150K	5% 1/10W
R3370	1-216-041-00	METAL GLAZE 470	5% 1/10W
R3371	1-216-095-00	METAL GLAZE 82K	5% 1/10W
R3372	1-216-041-00	METAL GLAZE 470	5% 1/10W
R3373	1-216-035-00	METAL GLAZE 270	5% 1/10W
<CRYSTAL>			
X3301	1-567-505-11	OSCILLATOR, CRYSTAL	
X3302	1-760-095-21	VIBRATOR, CRYSTAL	
*****			
* A-1297-720-A	AV BOARD, COMPLETE	***** (KV-27V35/29V35C/29V75M/32V35/34V35C)	
* A-1297-850-A	AV BOARD, COMPLETE	***** (KV-27V25/29V65M/32V25)	
<CAPACITOR>			
C101	1-124-903-11	ELECT 1MF 20% 50V	(except 27V25/29V65M/32V25)
C102	1-164-161-11	CERAMIC CHIP 0.0022MF 10% 50V	(except 27V25/29V65M/32V25)
C104	1-126-964-11	ELECT 10MF 20% 50V	(except 27V25/29V65M/32V25)
C106	1-104-664-11	ELECT 47MF 20% 25V	(except 27V25/29V65M/32V25)
C108	1-126-933-11	ELECT 100MF 20% 16V	(except 27V25/29V65M/32V25)
C109	1-163-125-00	CERAMIC CHIP 220PF 5% 50V	(except 27V25/29V65M/32V25)
C110	1-104-760-11	CERAMIC CHIP 0.047MF 10% 50V	(except 27V25/29V65M/32V25)
C111	1-124-903-11	ELECT 1MF 20% 50V	(except 27V25/29V65M/32V25)
C113	1-126-934-11	ELECT 220MF 20% 16V	(except 27V25/29V65M/32V25)
C1902	1-126-964-11	ELECT 10MF 20% 50V	
C1903	1-102-129-00	CERAMIC 0.01MF 10% 50V	
C1904	1-102-129-00	CERAMIC 0.01MF 10% 50V	
C1905	1-126-964-11	ELECT 10MF 20% 50V	
C1906	1-102-129-00	CERAMIC 0.01MF 10% 50V	
C1907	1-126-964-11	ELECT 10MF 20% 50V	
C1908	1-102-074-00	CERAMIC 0.001MF 10% 50V	
C1909	1-102-074-00	CERAMIC 0.001MF 10% 50V	
<CONNECTOR>			
CN101	1-573-301-21	CONNECTOR, BOARD TO BOARD 20P	
CN102	1-573-979-21	CONNECTOR, BOARD TO BOARD 11P	
CN103	* 1-564-507-11	PLUG, CONNECTOR 4P	(except 27V25/29V65M/32V25)

REF. NO.	PART NO.	DESCRIPTION	REMARK
<DIODE>			
D101	8-719-109-89	DIODE RD5.6ESB2	(except 27V25/29V65M/32V25)
D103	8-719-991-33	DIODE 1SS133T-77	(except 27V25/29V65M/32V25)
D104	8-719-991-33	DIODE 1SS133T-77	(except 27V25/29V65M/32V25)
<IC>			
IC1901	8-752-058-68	IC CXA1315M	
IC1902	8-759-981-61	IC LM2901M	
IC1903	8-759-356-27	IC NJM2129M-TE2	
<COIL>			
L102	1-410-470-11	INDUCTOR 10UH	(except 27V25/29V65M/32V25)
L105	1-408-421-00	INDUCTOR 100UH	(except 27V25/29V65M/32V25)
<TRANSISTOR>			
Q101	8-729-119-78	TRANSISTOR 2SC2785-HFE	(except 27V25/29V65M/32V25)
Q103	8-729-216-22	TRANSISTOR 2SA1162-G	(except 27V25/29V65M/32V25)
Q104	8-729-216-22	TRANSISTOR 2SA1162-G	(except 27V25/29V65M/32V25)
Q105	8-729-216-22	TRANSISTOR 2SA1162-G	(except 27V25/29V65M/32V25)
Q1901	8-729-216-22	TRANSISTOR 2SA1162-G	
Q1902	8-729-216-22	TRANSISTOR 2SA1162-G	
Q1906	8-729-216-22	TRANSISTOR 2SA1162-G	
Q1908	8-729-216-22	TRANSISTOR 2SA1162-G	
Q1911	8-729-422-27	TRANSISTOR 2SD601A-Q	
Q1912	8-729-422-27	TRANSISTOR 2SD601A-Q	
Q1914	8-729-216-22	TRANSISTOR 2SA1162-G	
Q1916	8-729-422-27	TRANSISTOR 2SD601A-Q	
Q1917	8-729-422-27	TRANSISTOR 2SD601A-Q	
<RESISTOR>			
R101	1-216-065-00	METAL GLAZE 4.7K	5% 1/10W (except 27V25/29V65M/32V25)
R102	1-216-083-00	METAL GLAZE 27K	5% 1/10W (except 27V25/29V65M/32V25)
R103	1-216-689-11	METAL GLAZE 39K	5% 1/10W (except 27V25/29V65M/32V25)
R104	1-216-045-00	METAL GLAZE 680	5% 1/10W (except 27V25/29V65M/32V25)
R106	1-216-081-00	METAL GLAZE 22K	5% 1/10W (except 27V25/29V65M/32V25)
R107	1-216-081-00	METAL GLAZE 22K	5% 1/10W (except 27V25/29V65M/32V25)
R108	1-216-081-00	METAL GLAZE 22K	5% 1/10W (except 27V25/29V65M/32V25)
R109	1-216-081-00	METAL GLAZE 22K	5% 1/10W (except 27V25/29V65M/32V25)
R112	1-249-421-11	CARBON 2.2K	5% 1/4W (except 27V25/29V65M/32V25)
R113	1-216-097-91	METAL GLAZE 100K	5% 1/10W (except 27V25/29V65M/32V25)
R114	1-216-121-91	METAL GLAZE 1M	5% 1/10W (except 27V25/29V65M/32V25)
R115	1-216-073-00	METAL GLAZE 10K	5% 1/10W (except 27V25/29V65M/32V25)
R116	1-216-073-00	METAL GLAZE 10K	5% 1/10W (except 27V25/29V65M/32V25)
R117	1-216-065-00	METAL GLAZE 4.7K	5% 1/10W (except 27V25/29V65M/32V25)
R1904	1-216-073-00	METAL GLAZE 10K	5% 1/10W



Les composants identifiés par une trame et une marque  $\Delta$  sont critiques pour la sécurité. Ne les remplacer que par une pièce portant le numéro spécifique.

The components identified by shading and mark  $\Delta$  are critical for safety. Replace only with part number specified.

REF. NO.	PART NO.	DESCRIPTION	REMARK
R1905	1-216-073-00	METAL GLAZE 10K	5% 1/10W
R1910	1-216-073-00	METAL GLAZE 10K	5% 1/10W
R1911	1-216-073-00	METAL GLAZE 10K	5% 1/10W
R1915	1-216-073-00	METAL GLAZE 10K	5% 1/10W
R1916	1-216-073-00	METAL GLAZE 10K	5% 1/10W
R1922	1-216-043-91	METAL GLAZE 560	5% 1/10W
R1923	1-216-043-91	METAL GLAZE 560	5% 1/10W
R1928	1-216-041-00	METAL GLAZE 470	5% 1/10W
R1929	1-216-089-91	METAL GLAZE 47K	5% 1/10W
R1930	1-216-073-00	METAL GLAZE 10K	5% 1/10W
R1931	1-216-025-91	METAL GLAZE 100	5% 1/10W
R1932	1-216-073-00	METAL GLAZE 10K	5% 1/10W
R1934	1-216-097-91	METAL GLAZE 100K	5% 1/10W
R1935	1-216-295-91	CONDUCTOR, CHIP	
R1936	1-216-081-00	METAL GLAZE 22K	5% 1/10W
R1937	1-216-073-00	METAL GLAZE 10K	5% 1/10W
R1940	1-216-065-00	METAL GLAZE 4.7K	5% 1/10W
R2901	1-216-081-00	METAL GLAZE 22K	5% 1/10W
R2903	1-216-065-00	METAL GLAZE 4.7K	5% 1/10W
R2904	1-216-033-00	METAL GLAZE 220	5% 1/10W
R2905	1-216-033-00	METAL GLAZE 220	5% 1/10W
R2906	1-216-033-00	METAL GLAZE 220	5% 1/10W
R2907	1-216-065-00	METAL GLAZE 4.7K	5% 1/10W
R2908	1-216-073-00	METAL GLAZE 10K	5% 1/10W
R2909	1-216-073-00	METAL GLAZE 10K	5% 1/10W
R2910	1-216-073-00	METAL GLAZE 10K	5% 1/10W
R2911	1-216-061-00	METAL GLAZE 3.3K	5% 1/10W
R2912	1-249-425-11	CARBON 4.7K	5% 1/4W
R2913	1-216-073-00	METAL GLAZE 10K	5% 1/10W
R2914	1-216-073-00	METAL GLAZE 10K	5% 1/10W
R2916	1-216-073-00	METAL GLAZE 10K	5% 1/10W
R2917	1-216-073-00	METAL GLAZE 10K	5% 1/10W
R2918	1-216-073-00	METAL GLAZE 10K	5% 1/10W

<TUNER>

TU101  $\Delta$  8-598-339-00 TUNER BTF-LA402  
(except 27V25/29V65M/32V25)

\*\*\*\*\*

- \* A-1297-806-A A BOARD, COMPLETE  
\*\*\*\*\*  
(KV-27V20/29V20M)
- \* A-1297-807-A A BOARD, COMPLETE  
\*\*\*\*\*  
(KV-27V35/29V35C/29V75M)
- \* A-1297-812-A A BOARD, COMPLETE  
\*\*\*\*\*  
(KV-32V35/34V35C)
- \* A-1297-851-A A BOARD, COMPLETE  
\*\*\*\*\*  
(KV-27V25/29V65M)
- \* A-1297-862-A A BOARD, COMPLETE (KV-32V25)  
\*\*\*\*\*
- \* 4-051-927-01 CASE, SHIELD  
4-382-854-11 SCREW (M3X10), P, SW (+)

<CAPACITOR>

C001	1-163-125-00	CERAMIC CHIP 220PF	5%	50V
C003	1-104-760-11	CERAMIC CHIP 0.047MF	10%	50V
C005	1-124-903-11	ELECT 1MF	20%	50V
C009	1-126-967-11	ELECT 47MF	20%	50V
C010	1-163-033-91	CERAMIC CHIP 0.022MF		50V
C011	1-163-017-00	CERAMIC CHIP 0.0047MF	10%	50V

REF. NO.	PART NO.	DESCRIPTION	REMARK
C012	1-164-005-11	CERAMIC CHIP 0.47MF	25V
C013	1-163-017-00	CERAMIC CHIP 0.0047MF	10% 50V
C023	1-163-125-00	CERAMIC CHIP 220PF	5% 50V
C028	1-163-227-11	CERAMIC CHIP 10PF	0.5PF 50V
C029	1-163-227-11	CERAMIC CHIP 10PF	0.5PF 50V
C030	1-163-009-11	CERAMIC CHIP 0.001MF	10% 50V
C035	1-163-237-11	CERAMIC CHIP 27PF	5% 50V
C036	1-163-231-11	CERAMIC CHIP 15PF	5% 50V
C037	1-163-243-11	CERAMIC CHIP 47PF	5% 50V
C038	1-163-243-11	CERAMIC CHIP 47PF	5% 50V
C039	1-163-243-11	CERAMIC CHIP 47PF	5% 50V
C040	1-163-243-11	CERAMIC CHIP 47PF	5% 50V
C051	1-164-161-11	CERAMIC CHIP 0.0022MF	10% 50V
C053	1-164-232-11	CERAMIC CHIP 0.01MF	10% 50V
C056	1-163-243-11	CERAMIC CHIP 47PF	5% 50V
C061	1-163-033-91	CERAMIC CHIP 0.022MF	50V
C062	1-163-033-91	CERAMIC CHIP 0.022MF	50V
C063	1-126-935-11	ELECT 470MF	20% 16V
C071	1-164-096-11	CERAMIC 0.01MF	50V
C072	1-164-161-11	CERAMIC CHIP 0.0022MF	10% 50V
C353	1-163-231-11	CERAMIC CHIP 15PF	5% 50V
C354	1-163-133-00	CERAMIC CHIP 470PF	5% 50V
C355	1-124-902-00	ELECT 0.47MF	20% 50V
C356	1-126-963-11	ELECT 4.7MF	20% 50V
C357	1-124-902-00	ELECT 0.47MF	20% 50V
C358	1-164-232-11	CERAMIC CHIP 0.01MF	10% 50V
C359	1-126-933-11	ELECT 100MF	20% 16V
C360	1-124-902-00	ELECT 0.47MF	20% 50V
C361	1-124-902-00	ELECT 0.47MF	20% 50V (except 27V20/29V20M) (except 27V20/29V20M)
C362	1-124-902-00	ELECT 0.47MF	20% 50V (except 27V20/29V20M)
C363	1-164-232-11	CERAMIC CHIP 0.01MF	10% 50V
C364	1-164-232-11	CERAMIC CHIP 0.01MF	10% 50V
C365	1-164-232-11	CERAMIC CHIP 0.01MF	10% 50V
C366	1-137-399-11	FILM 0.1MF	5% 50V
C367	1-137-399-11	FILM 0.1MF	5% 50V
C368	1-137-399-11	FILM 0.1MF	5% 50V
C369	1-163-243-11	CERAMIC CHIP 47PF	5% 50V
C370	1-163-037-11	CERAMIC CHIP 0.022MF	10% 50V
C371	1-163-141-00	CERAMIC CHIP 0.001MF	5% 50V
C372	1-124-902-00	ELECT 0.47MF	20% 50V
C373	1-124-903-11	ELECT 1MF	20% 50V
C375	1-165-319-11	CERAMIC CHIP 0.1MF	50V (27V20/29V20M)
C376	1-126-964-11	ELECT 10MF	20% 50V
C377	1-137-399-11	FILM 0.1MF	5% 50V
C378	1-136-244-11	FILM 0.1MF	5% 50V
C379	1-164-232-11	CERAMIC CHIP 0.01MF	10% 50V
C380	1-126-935-11	ELECT 470MF	20% 16V
C381	1-163-003-11	CERAMIC CHIP 330PF	10% 50V
C383	1-137-399-11	FILM 0.1MF	5% 50V
C385	1-164-182-11	CERAMIC CHIP 0.0033MF	10% 50V
C386	1-164-232-11	CERAMIC CHIP 0.01MF	10% 50V
C387	1-124-925-11	ELECT 2.2MF	20% 50V
C388	1-124-902-00	ELECT 0.47MF	20% 50V
C390	1-124-903-11	ELECT 1MF	20% 50V
C391	1-163-017-00	CERAMIC CHIP 0.0047MF	10% 50V
C392	1-163-251-11	CERAMIC CHIP 100PF	5% 50V
C461	1-126-963-11	ELECT 4.7MF	20% 50V (27V35/29V35C/29V75M)
C461	1-126-964-11	ELECT 10MF	20% 50V (32V25)
C461	1-128-551-11	ELECT 22MF	20% 25V (27V20/27V25/29V20M/29V65M)
C462	1-124-925-11	ELECT 2.2MF	20% 50V
C463	1-124-925-11	ELECT 2.2MF	20% 50V
C466	1-104-666-11	ELECT 220MF	20% 25V
C468	1-104-664-11	ELECT 47MF	20% 25V

The components identified by shading and mark  $\Delta$  are critical for safety. Replace only with part number specified.

Les composants identifiés par une trame et une marque  $\Delta$  sont critiques pour la sécurité. Ne les remplacer que par une pièce portant le numéro spécifique.

**A**

REF. NO.	PART NO.	DESCRIPTION	REMARK
C470	1-124-925-11	ELECT 2.2MF 20% 50V	
C471	1-104-666-11	ELECT 220MF 20% 25V	
C472	1-136-173-00	FILM 0.47MF 5% 50V	
C473	1-136-169-00	FILM 0.22MF 5% 50V	
C474	1-126-942-61	ELECT 1000MF 20% 25V	
C475	1-136-169-00	FILM 0.22MF 5% 50V	
C476	1-126-942-61	ELECT 1000MF 20% 25V (27V20/27V25/29V20M/29V65M/32V25)	
C477	1-126-942-61	ELECT 1000MF 20% 25V (27V20/27V25/29V20M/29V65M/32V25)	
C501	1-102-110-00	CERAMIC 220PF 10% 50V	
C502	1-124-902-00	ELECT 0.47MF 20% 50V	
C503	1-163-003-11	CERAMIC CHIP 330PF 10% 50V	
C504	1-102-212-00	CERAMIC 820PF 10% 500V	
C505	1-102-002-00	CERAMIC 680PF 10% 500V	
C506	1-106-383-00	MYLAR 0.047MF 10% 200V	
C507	$\Delta$ 1-162-116-51	CERAMIC 680PF 10% 2KV	
C508	1-102-244-00	CERAMIC 220PF 10% 500V	
C509	1-162-116-00	CERAMIC 680PF 10% 2KV	
C510	1-106-367-00	MYLAR 0.01MF 10% 100V	
C511	$\Delta$ 1-115-460-11	FILM 0.022MF 3% 1.2KV	
C513	$\Delta$ 1-130-895-51	FILM 0.056MF 5% 400V	
C514	$\Delta$ 1-104-844-11	FILM 0.62MF 5% 200V	
C515	1-106-343-00	MYLAR 0.001MF 10% 100V	
C516	1-115-461-11	FILM 2MF 5% 200V	
C517	1-107-649-11	ELECT 2.2MF 20% 250V	
C518	1-106-395-00	MYLAR 0.15MF 10% 200V	
C519	1-162-815-11	CERAMIC 47PF 5% 500V	
C520	1-164-645-11	CERAMIC 1000PF 10% 500V (32V25/32V35/34V35C)	
C520	1-164-646-11	CERAMIC 2200PF 10% 500V (except 32V25/32V35/34V35C)	
C521	1-164-161-11	CERAMIC CHIP 0.0022MF 10% 50V	
C522	1-124-903-11	ELECT 1MF 20% 50V	
C525	1-102-244-00	CERAMIC 220PF 10% 500V	
C526	1-107-662-11	ELECT 22MF 20% 250V	
C527	1-162-116-00	CERAMIC 680PF 10% 2KV	
C528	1-164-161-11	CERAMIC CHIP 0.0022MF 10% 50V	
C529	1-128-551-11	ELECT 22MF 20% 25V	
C530	1-137-366-11	FILM 0.0022MF 5% 50V	
C531	1-126-965-11	ELECT 22MF 20% 50V	
C532	1-126-965-11	ELECT 22MF 20% 50V	
C537	1-126-941-11	ELECT 470MF 20% 25V	
C539	$\Delta$ 1-126-935-91	ELECT 470MF 20% 16V	
C540	1-123-024-21	ELECT 33MF 160V	
C541	1-128-560-11	ELECT 22MF 20% 100V	
C545	1-106-387-00	MYLAR 0.068MF 10% 200V	
C546	1-106-343-00	MYLAR 0.001MF 10% 100V	
C547	1-106-343-00	MYLAR 0.001MF 10% 100V	
C561	1-126-967-11	ELECT 47MF 20% 50V	
C563	1-126-923-11	ELECT 220MF 20% 10V	
C564	1-124-903-11	ELECT 1MF 20% 50V	
C565	1-126-969-11	ELECT 220MF 20% 50V	
C566	1-126-964-11	ELECT 10MF 20% 50V	
C568	1-136-169-00	FILM 0.22MF 5% 50V	
C571	1-104-664-11	ELECT 47MF 20% 25V	
C1002	1-126-964-11	ELECT 10MF 20% 50V	
C1101	1-126-768-11	ELECT 2200MF 20% 16V	
C1103	1-126-965-11	ELECT 22MF 20% 50V	
C1104	1-126-967-11	ELECT 47MF 20% 16V	
C1105	1-126-967-11	ELECT 47MF 20% 16V	
C1106	1-126-964-11	ELECT 10MF 20% 50V	
C1107	1-163-037-11	CERAMIC CHIP 0.022MF 10% 50V	
C1108	1-124-903-11	ELECT 1MF 20% 50V	
C1109	1-126-964-11	ELECT 10MF 20% 50V	
C1110	1-163-227-11	CERAMIC CHIP 10PF 0.5PF 50V	
C1111	1-163-227-11	CERAMIC CHIP 10PF 0.5PF 50V	
C1112	1-163-227-11	CERAMIC CHIP 10PF 0.5PF 50V	
C1244	1-124-902-00	ELECT 0.47MF 20% 50V	

REF. NO.	PART NO.	DESCRIPTION	REMARK
C1245	1-124-902-00	ELECT 0.47MF 20% 50V	
C1351	1-163-251-11	CERAMIC CHIP 100PF 5% 50V	
C1352	1-126-933-11	ELECT 100MF 20% 16V	
C1353	1-163-037-11	CERAMIC CHIP 0.022MF 10% 50V	
C1354	1-216-295-91	CONDUCTOR, CHIP	
C1401	1-124-902-00	ELECT 0.47MF 20% 50V	
C1402	1-126-964-11	ELECT 10MF 20% 50V	
C1403	1-124-902-00	ELECT 0.47MF 20% 50V	
C1404	1-165-319-11	CERAMIC CHIP 0.1MF 50V	
C1405	1-165-319-11	CERAMIC CHIP 0.1MF 50V	
C1406	1-165-319-11	CERAMIC CHIP 0.1MF 50V	
C1407	1-165-319-11	CERAMIC CHIP 0.1MF 50V	
C1408	1-164-161-11	CERAMIC CHIP 0.0022MF 10% 50V	
C1409	1-164-161-11	CERAMIC CHIP 0.0022MF 10% 50V	
C1410	1-164-161-11	CERAMIC CHIP 0.0022MF 10% 50V	
C1411	1-164-161-11	CERAMIC CHIP 0.0022MF 10% 50V	
C1412	1-124-925-11	ELECT 2.2MF 20% 50V	
C1413	1-124-925-11	ELECT 2.2MF 20% 50V	
C1414	1-164-489-11	CERAMIC CHIP 0.22MF 10% 16V	
C1415	1-126-965-11	ELECT 22MF 20% 50V	
C1416	1-126-933-11	ELECT 100MF 20% 16V	
C1417	1-126-952-11	ELECT 1000MF 20% 16V	
C1420	1-164-005-11	CERAMIC CHIP 0.47MF 25V	
C1501	1-115-462-11	FILM 0.12MF 5% 200V (32V25/32V35/34V35C)	
<CONNECTOR>			
CN270	1-573-298-11	CONNECTOR, BOARD TO BOARD 20P	
CN271	1-573-978-21	CONNECTOR, BOARD TO BOARD 11P	
CN351	* 1-564-509-11	PLUG, CONNECTOR 6P	
CN461	* 1-564-507-11	PLUG, CONNECTOR 4P (27V20/27V25/29V20M/29V65M/32V25)	
CN461	* 1-564-510-11	PLUG, CONNECTOR 7P (27V35/29V35C/29V75M/32V35/34V35C)	
CN501	* 1-580-798-11	CONNECTOR PIN (DY) 6P	
CN503	* 1-564-507-11	PLUG, CONNECTOR 4P	
CN1001	* 1-564-512-11	PLUG, CONNECTOR 9P	
CN1101	1-573-298-11	CONNECTOR, BOARD TO BOARD 20P (except 27V20/29V20M)	
CN1103	1-573-979-21	CONNECTOR, BOARD TO BOARD 11P	
CN1231	1-564-511-11	PLUG, CONNECTOR 8P	
CN1641	* 1-564-515-11	PLUG, CONNECTOR 12P	
CN1941	* 1-564-508-11	PLUG, CONNECTOR 5P (27V35/29V35C/29V75M/32V35/34V35C)	
CN3001	1-573-298-11	CONNECTOR, BOARD TO BOARD 20P	
<DIODE>			
D001	8-719-991-33	DIODE 1SS133T-77	
D002	8-719-109-89	DIODE RD5.6ESB2	
D003	8-719-991-33	DIODE 1SS133T-77	
D004	8-719-110-17	DIODE RD10ESB2	
D011	8-719-983-20	DIODE MTZJ-T-77-4.3C	
D013	8-719-991-33	DIODE 1SS133T-77	
D014	8-719-991-33	DIODE 1SS133T-77	
D015	8-719-991-33	DIODE 1SS133T-77	
D353	8-719-991-33	DIODE 1SS133T-77	
D356	8-719-991-33	DIODE 1SS133T-77	
D360	8-719-110-17	DIODE RD10ESB2	
D362	8-719-991-33	DIODE 1SS133T-77	
D368	8-719-991-33	DIODE 1SS133T-77	
D462	8-719-991-33	DIODE 1SS133T-77	
D501	8-719-109-89	DIODE RD5.6ESB2	
D502	8-719-945-80	DIODE ERC06-15S	
D503	8-719-945-80	DIODE ERC06-15S	
D504	8-719-900-26	DIODE ERD29-08J	
D505	8-719-908-03	DIODE GP08D	
D506	8-719-908-03	DIODE GP08D	



Les composants identifiés par une trame et une marque  $\Delta$  sont critiques pour la sécurité. Ne les remplacer que par une pièce portant le numéro spécifique.

The components identified by shading and mark  $\Delta$  are critical for safety. Replace only with part number specified.

REF. NO.	PART NO.	DESCRIPTION	REMARK	REF. NO.	PART NO.	DESCRIPTION	REMARK
D507	8-719-991-33	DIODE 1SS133T-77		L1401	1-410-494-11	INDUCTOR 1mH	
D515	8-719-302-43	DIODE EL1Z					
D516	8-719-991-33	DIODE 1SS133T-77					
D518	8-719-991-33	DIODE 1SS133T-77					
D519	$\Delta$ 8-719-302-44	DIODE EL1Z-V1				<IC LINK>	
D520	8-719-991-33	DIODE 1SS133T-77		PS461	$\Delta$ 1-532-984-91	LINK, IC (2A/90V)	
D521	8-719-921-63	DIODE MTZJ-7.5B					
D530	8-719-979-85	DIODE EGP20G				<TRANSISTOR>	
D531	8-719-979-85	DIODE EGP20G					
D534	8-719-302-43	DIODE EL1Z		Q001	8-729-216-22	TRANSISTOR 2SA1162-G	
D561	8-719-908-03	DIODE GP08D		Q002	8-729-422-27	TRANSISTOR 2SD601A-Q	
D562	8-719-911-19	DIODE 1SS119-25 (27V25/29V65M)		Q003	8-729-422-27	TRANSISTOR 2SD601A-Q	
D562	8-719-991-33	DIODE 1SS133T-77		Q004	8-729-216-22	TRANSISTOR 2SA1162-G	
D1102	8-719-982-24	DIODE MTZJ-33A		Q010	8-729-422-27	TRANSISTOR 2SD601A-Q	
D1103	8-719-109-89	DIODE RD5.6ESB2		Q011	8-729-422-27	TRANSISTOR 2SD601A-Q	
D1248	8-719-981-99	DIODE MTZJ-T-77-3.3		Q012	8-729-422-27	TRANSISTOR 2SD601A-Q	
D1263	8-719-110-17	DIODE RD10ESB2		Q013	8-729-422-27	TRANSISTOR 2SD601A-Q	
D1264	8-719-110-17	DIODE RD10ESB2		Q014	8-729-422-27	TRANSISTOR 2SD601A-Q	
		<FERRITE BEAD>		Q015	8-729-422-27	TRANSISTOR 2SD601A-Q	
FB501	1-410-396-41	FERRITE BEAD INDUCTOR 0.45UH		Q016	8-729-422-27	TRANSISTOR 2SD601A-Q	
FB502	1-410-397-21	FERRITE BEAD INDUCTOR 1.1UH		Q017	8-729-216-22	TRANSISTOR 2SA1162-G	
FB503	1-410-397-21	FERRITE BEAD INDUCTOR 1.1UH		Q301	8-729-216-22	TRANSISTOR 2SA1162-G	
		<IC>		Q302	8-729-216-22	TRANSISTOR 2SA1162-G	
IC001	8-752-874-16	IC CXP85640-005S		Q303	8-729-216-22	TRANSISTOR 2SA1162-G	
IC002	8-759-354-28	IC ST24C02FM6TR		Q354	8-729-422-27	TRANSISTOR 2SD601A-Q	
IC351	8-752-076-08	IC CXA2025S		Q356	8-729-216-22	TRANSISTOR 2SA1162-G	
IC461	8-759-980-43	IC TDA2009A		Q357	8-729-422-27	TRANSISTOR 2SD601A-Q (27V35/29V35C/29V75M/32V35/34V35C)	
IC501	8-759-700-07	IC NJM2903M		Q358	8-729-422-27	TRANSISTOR 2SD601A-Q	
IC561	8-759-980-58	IC TDA8172		Q461	8-729-422-27	TRANSISTOR 2SD601A-Q	
IC1001	8-752-058-68	IC CXA1315M		Q462	8-729-216-22	TRANSISTOR 2SA1162-G	
IC1401	8-759-369-39	IC BH3856FS-E2		Q501	8-729-140-96	TRANSISTOR 2SD774-34	
IC1402	8-759-100-96	IC uPC4558G2		Q502	$\Delta$ 8-729-018-96	TRANSISTOR 2SC4927-02	
		<CHIP CONDUCTOR>		Q503	8-729-422-27	TRANSISTOR 2SD601A-Q	
JR001	1-216-295-91	CONDUCTOR, CHIP		Q511	$\Delta$ 8-729-422-26	TRANSISTOR 2SD601A-QRS-TX	
JR351	1-216-295-91	CONDUCTOR, CHIP (27V20/29V20M)		Q512	$\Delta$ 8-729-809-29	TRANSISTOR 2SC4159-E	
JR352	1-216-295-91	CONDUCTOR, CHIP (27V20/29V20M)		Q561	8-729-422-27	TRANSISTOR 2SD601A-Q	
JR1351	1-216-295-91	CONDUCTOR, CHIP		Q562	8-729-422-27	TRANSISTOR 2SD601A-Q	
JR1352	1-216-295-91	CONDUCTOR, CHIP		Q563	8-729-105-08	TRANSISTOR 2SA1330-06	
JR4101	1-216-295-91	CONDUCTOR, CHIP		Q1102	8-729-119-78	TRANSISTOR 2SC2785-HFE	
JR4108	1-216-295-91	CONDUCTOR, CHIP		Q1103	8-729-422-27	TRANSISTOR 2SD601A-Q	
JR4110	1-216-295-91	CONDUCTOR, CHIP		Q1231	8-729-422-27	TRANSISTOR 2SD601A-Q	
JR4114	1-216-295-91	CONDUCTOR, CHIP		Q1232	8-729-422-27	TRANSISTOR 2SD601A-Q	
JR4116	1-216-295-91	CONDUCTOR, CHIP				<RESISTOR>	
JR4120	1-216-295-91	CONDUCTOR, CHIP		R001	1-216-045-00	METAL GLAZE 680	5% 1/10W
		<COIL>		R002	1-247-815-91	CARBON 220	5% 1/4W
L001	1-408-421-00	INDUCTOR 100UH		R003	1-216-097-91	METAL GLAZE 100K	5% 1/10W
L002	1-408-421-00	INDUCTOR 100UH		R004	1-216-121-91	METAL GLAZE 1M	5% 1/10W
L003	1-410-470-11	INDUCTOR 10UH		R005	1-247-815-91	CARBON 220	5% 1/4W
L004	1-410-470-11	INDUCTOR 10UH		R006	1-247-815-91	CARBON 220	5% 1/4W (except 27V20/29V20M)
L352	1-412-537-31	INDUCTOR 100UH		R007	1-216-073-00	METAL GLAZE 10K	5% 1/10W
L461	1-410-470-11	INDUCTOR 10UH (27V20/27V25/29V20M/29V65M)		R008	1-247-815-91	CARBON 220	5% 1/4W (except 27V20/29V20M)
L461	1-410-472-41	INDUCTOR 15UH (32V25)		R009	1-216-073-00	METAL GLAZE 10K	5% 1/10W
L461	1-410-473-11	INDUCTOR 18UH (27V35/29V35C/29V75M)		R010	1-216-037-00	METAL GLAZE 330	5% 1/10W
L501	$\Delta$ 1-409-861-11	COIL HORIZONTAL LINEARITY		R011	1-216-065-00	METAL GLAZE 4.7K	5% 1/10W
L502	1-412-552-11	INDUCTOR 2.2mH		R012	1-216-033-00	METAL GLAZE 220	5% 1/10W
L503	1-406-677-11	COIL, CHOKe 10mH		R013	1-216-065-00	METAL GLAZE 4.7K	5% 1/10W
L511	1-406-607-11	COIL, CHOKe 15mH		R014	1-216-065-00	METAL GLAZE 4.7K	5% 1/10W
L517	1-412-552-11	INDUCTOR 2.2mH		R015	1-216-073-00	METAL GLAZE 10K	5% 1/10W
L1101	1-408-421-00	INDUCTOR 100UH		R016	1-216-073-00	METAL GLAZE 10K	5% 1/10W
L1102	1-410-470-11	INDUCTOR 10UH		R019	1-249-425-11	CARBON 4.7K	5% 1/4W
				R020	1-216-065-00	METAL GLAZE 4.7K	5% 1/10W
				R022	1-249-429-11	CARBON 10K	5% 1/4W (except 27V20/29V20M)
				R023	1-216-089-91	METAL GLAZE 47K	5% 1/10W
				R024	1-216-085-00	METAL GLAZE 33K	5% 1/10W



REF. NO.	PART NO.	DESCRIPTION	REMARK
R025	1-216-121-91	METAL GLAZE 1M	5% 1/10W
R026	1-216-019-00	METAL GLAZE 56	5% 1/10W
R027	1-216-049-91	METAL GLAZE 1K	5% 1/10W
R028	1-249-417-11	CARBON 1K	(except 27V20/29V20M) 5% 1/4W
R029	1-216-025-91	METAL GLAZE 100	5% 1/10W
R030	1-249-425-11	CARBON 4.7K	5% 1/4W
R031	1-247-815-91	CARBON 220	5% 1/4W
R032	1-247-815-91	CARBON 220	(except 27V20/29V20M) 5% 1/4W
R034	1-247-815-91	CARBON 220	5% 1/4W
R035	1-247-815-91	CARBON 220	5% 1/4W
R036	1-216-049-91	METAL GLAZE 1K	5% 1/10W
R037	1-216-049-91	METAL GLAZE 1K	5% 1/10W
R038	1-216-049-91	METAL GLAZE 1K	5% 1/10W
R039	1-247-807-31	CARBON 100	5% 1/4W
R040	1-247-815-91	CARBON 220	5% 1/4W
R041	1-216-065-00	METAL GLAZE 4.7K	(except 27V20/29V20M) 5% 1/10W
R042	1-216-065-00	METAL GLAZE 4.7K	(except 27V20/29V20M) 5% 1/10W
R043	1-216-049-91	METAL GLAZE 1K	5% 1/10W
R044	1-216-049-91	METAL GLAZE 1K	5% 1/10W
R045	1-247-815-91	CARBON 220	5% 1/4W
R046	1-247-815-91	CARBON 220	(except 27V20/29V20M) 5% 1/4W
R047	1-249-417-11	CARBON 1K	5% 1/4W
R048	1-249-417-11	CARBON 1K	5% 1/4W
R049	1-249-417-11	CARBON 1K	5% 1/4W
R050	1-247-815-91	CARBON 220	5% 1/4W
R051	1-247-815-91	CARBON 220	(except 27V20/29V20M) 5% 1/4W
R052	1-216-061-00	METAL GLAZE 3.3K	5% 1/10W
R053	1-216-061-00	METAL GLAZE 3.3K	5% 1/10W
R054	1-216-061-00	METAL GLAZE 3.3K	5% 1/10W
R055	1-216-097-91	METAL GLAZE 100K	5% 1/10W
R056	1-216-033-00	METAL GLAZE 220	5% 1/10W
R057	1-249-417-11	CARBON 1K	5% 1/4W
R058	1-216-033-00	METAL GLAZE 220	5% 1/10W
R064	1-247-815-91	CARBON 220	5% 1/4W
R065	1-247-815-91	CARBON 220	5% 1/4W
R066	1-247-815-91	CARBON 220	5% 1/4W
R067	1-249-413-11	CARBON 470	5% 1/4W
R068	1-247-815-91	CARBON 220	5% 1/4W
R069	1-247-815-91	CARBON 220	5% 1/4W
R070	1-247-815-91	CARBON 220	5% 1/4W
R071	1-247-815-91	CARBON 220	5% 1/4W
R072	1-216-033-00	METAL GLAZE 220	5% 1/10W
R073	1-216-033-00	METAL GLAZE 220	5% 1/10W
R074	1-216-033-00	METAL GLAZE 220	5% 1/10W
R075	1-216-033-00	METAL GLAZE 220	5% 1/10W
R076	1-216-033-00	METAL GLAZE 220	5% 1/10W
R077	1-216-033-00	METAL GLAZE 220	5% 1/10W
R078	1-249-417-11	CARBON 1K	5% 1/4W
R079	1-216-033-00	METAL GLAZE 220	5% 1/10W
R080	1-216-065-00	METAL GLAZE 4.7K	5% 1/10W
R081	1-216-025-91	METAL GLAZE 100	5% 1/10W
R082	1-216-025-91	METAL GLAZE 100	5% 1/10W
R083	1-249-429-11	CARBON 10K	5% 1/4W
R084	1-216-049-91	METAL GLAZE 1K	5% 1/10W
R087	1-247-815-91	CARBON 220	5% 1/4W
R090	1-216-033-00	METAL GLAZE 220	5% 1/10W
R092	1-249-429-11	CARBON 10K	(except 27V20/29V20M) 5% 1/4W
R097	1-216-065-00	METAL GLAZE 4.7K	5% 1/10W
R099	1-216-065-00	METAL GLAZE 4.7K	5% 1/10W
R131	1-216-035-00	METAL GLAZE 270	5% 1/10W
R132	1-216-115-00	METAL GLAZE 560K	5% 1/10W
R133	1-216-039-00	METAL GLAZE 390	5% 1/10W

REF. NO.	PART NO.	DESCRIPTION	REMARK
R135	1-216-073-00	METAL GLAZE 10K	5% 1/10W
R136	1-216-073-00	METAL GLAZE 10K	5% 1/10W
R137	1-216-047-91	METAL GLAZE 820	5% 1/10W
R353	1-208-786-11	METAL GLAZE 1.5K	0.50% 1/10W
R354	1-216-077-00	METAL GLAZE 15K	5% 1/10W
R355	1-216-033-00	METAL GLAZE 220	5% 1/10W
R356	1-216-033-00	METAL GLAZE 220	5% 1/10W
R358	1-247-815-91	CARBON 220	5% 1/4W
R359	1-247-815-91	CARBON 220	(except 27V20/29V20M) 5% 1/4W
R360	1-247-815-91	CARBON 220	(except 27V20/29V20M) 5% 1/4W
R361	1-216-025-91	METAL GLAZE 100	5% 1/10W
R362	1-216-025-91	METAL GLAZE 100	5% 1/10W
R363	1-216-025-91	METAL GLAZE 100	5% 1/10W
R364	1-216-101-00	METAL GLAZE 150K	5% 1/10W
R365	1-216-101-00	METAL GLAZE 150K	5% 1/10W
R366	1-216-089-91	METAL GLAZE 47K	5% 1/10W
R367	1-216-097-91	METAL GLAZE 100K	5% 1/10W
R368	1-249-441-11	CARBON 100K	5% 1/4W
R369	1-216-097-91	METAL GLAZE 100K	5% 1/10W
R370	1-249-417-11	CARBON 1K	5% 1/4W
R371	1-216-053-00	METAL GLAZE 1.5K	(27V35/29V35C/29V75M/32V35/34V35C) 5% 1/10W
R372	1-216-113-00	METAL GLAZE 470K	(27V35/29V35C/29V75M/32V35/34V35C) 5% 1/10W
R373	1-216-073-00	METAL GLAZE 10K	5% 1/10W
R374	1-216-125-00	METAL GLAZE 1.5M	5% 1/10W
R375	1-216-025-91	METAL GLAZE 100	5% 1/10W
R376	1-216-073-00	METAL GLAZE 10K	5% 1/10W
R379	1-216-033-00	METAL GLAZE 220	5% 1/10W
R380	1-247-815-91	CARBON 220	5% 1/4W
R381	1-247-815-91	CARBON 220	5% 1/4W
R382	1-216-033-00	METAL GLAZE 220	5% 1/10W
R383	1-216-049-91	METAL GLAZE 1K	5% 1/10W
R384	1-216-109-00	METAL GLAZE 330K	5% 1/10W
R385	1-249-422-11	CARBON 2.7K	5% 1/4W
R386	1-216-049-91	METAL GLAZE 1K	5% 1/10W
R387	1-216-049-91	METAL GLAZE 1K	(except 27V20/29V20M) 5% 1/10W
R388	1-216-089-91	METAL GLAZE 47K	5% 1/10W
R389	1-216-067-00	METAL GLAZE 5.6K	5% 1/10W
R390	1-216-035-00	METAL GLAZE 270	5% 1/10W
R391	1-208-810-11	METAL GLAZE 15K	0.50% 1/10W
R392	1-216-025-91	METAL GLAZE 100	5% 1/10W
R393	1-216-043-91	METAL GLAZE 560	5% 1/10W
R394	1-216-059-00	METAL GLAZE 2.7K	5% 1/10W
R395	1-216-061-00	METAL GLAZE 3.3K	5% 1/10W
R396	1-249-417-11	CARBON 1K	5% 1/4W
R397	1-249-425-11	CARBON 4.7K	(27V35/29V35C/29V75M/32V35/34V35C) 5% 1/4W
R461	1-216-065-00	METAL GLAZE 4.7K	5% 1/10W
R462	1-216-089-91	METAL GLAZE 47K	5% 1/10W
R463	1-249-435-11	CARBON 33K	5% 1/4W
R464	1-216-097-91	METAL GLAZE 100K	5% 1/10W
R465	1-249-413-11	CARBON 470	5% 1/4W
R466	1-249-383-11	CARBON 1.5	5% 1/4W F
R466	1-249-385-11	CARBON 2.2	(27V35/29V35C/29V75M) 5% 1/4W F
R467	1-216-069-00	METAL GLAZE 6.8K	(27V20/27V25/29V20M/29V65M/32V25) 5% 1/10W
R469	1-216-055-00	METAL GLAZE 1.8K	(27V20/27V25/29V20M/29V65M/32V25) 5% 1/10W
R469	1-216-061-00	METAL GLAZE 3.3K	5% 1/10W
R469	1-216-067-00	METAL GLAZE 5.6K	(32V35/34V35C) 5% 1/10W
R471	1-216-069-00	METAL GLAZE 6.8K	(27V35/29V35C/29V75M) 5% 1/10W
R472	1-216-055-00	METAL GLAZE 1.8K	(27V20/27V25/29V20M/29V65M/32V25) 5% 1/10W