

# TOSHIBA

FILE NO. 023-200009

## SERVICE MANUAL

# COLOR TELEVISION

NOES Chassis

# 27A40

(TAC0015)

## – SUMMARY –

27A40 is the same as 27A50 except for the parts tabled on back of this sheet.  
Use this service manual together with the service manual of 27A50 (File No. 020-200004).

## REPLACEMENT PARTS LIST DIFFERENCES

Location No.	Part No.	Description
A201	23549910	Front Cover
A221	23104042	Lens
A222	23104045	Filter
A223	23445381	Button, Power
A224	23445382	Button, Control
A401	23005253	Back Cover
A703	23935360	Packing, Top
A708	23935361	Packing, Bottom
K912	23306316	Remote Hand Unit, CT-9995
Q503	23114528	Transistor, 2SC1740S, Q
R201	24366102	CF, 1k ohm
R202	24366102	CF, 1k ohm
R508	24366102	CF, 1k ohm
R509	24366102	CF, 1k ohm
R510	24366471	CF, 470 ohm
* U902		Main Board, PB9549B
W661	23151225	Speaker, SPK-1228, 60X90mm, 8 ohm
W662	23151225	Speaker, SPK-1228, 60X90mm, 8 ohm
Y101	23563899	Owner's Manual, English, 27A40
Y101F	23563900	Owner's Manual, French, 27A40

**TOSHIBA CORPORATION**

1-1, SHIBAURA 1-CHOME, MINATO-KU, TOKYO 105-8001, JAPAN

**TOSHIBA**

FILE NO. 020-200004

SERVICE MANUAL

# COLOR TELEVISION

NOES Chassis

# 27A50

(TAC0012)

# TABLE OF CONTENTS

## CHAPTER 1 GENERAL ADJUSTMENTS

SAFETY INSTRUCTIONS .....	3
SET-UP ADJUSTMENT .....	4
SERVICE MODE .....	8
DESIGN MODE .....	11
ELECTRICAL ADJUSTMENTS .....	12
CIRCUIT CHECKS .....	16

## CHAPTER 2 SPECIFIC INFORMATIONS

SETTING & ADJUSTING DATA .....	17
LOCATION OF CONTROLS .....	18
PROGRAMMING CHANNEL MEMORY .....	20
CIRCUIT BLOCK DIAGRAM .....	21
CHASSIS AND CABINET REPLACEMENT PARTS LIST .....	22
PC BOARDS BOTTOM VIEW .....	31
TERMINAL VIEW OF TRANSISTORS .....	34
SPECIFICATIONS .....	37

### APPENDIX:

CIRCUIT DIAGRAM

## SAFETY INSTRUCTIONS

**WARNING:** BEFORE SERVICING THIS CHASSIS, READ THE “X-RAY RADIATION PRECAUTION”, “SAFETY PRECAUTION” AND “PRODUCT SAFETY NOTICE” INSTRUCTIONS BELOW.

### X-RAY RADIATION PRECAUTION

- Excessive high voltage can produce potentially hazardous X-RAY RADIATION. To avoid such hazards, the high voltage must not be above the specified limit. The nominal value of the high voltage of this receiver is (A) kV at zero beam current (minimum brightness) under a 120V AC power source. The high voltage must not, under any circumstances, exceed (B) kV.
- This receiver is equipped with a Fail Safe (FS) circuit which prevents the receiver from producing an excessively high voltage even if the B+ voltage increases abnormally. Each time the receiver is serviced, the FS circuit must be checked to determine that the circuit is properly functioning, following the FS CIRCUIT CHECK procedure in this manual.
- The only source of X-RAY RADIATION in this TV receiver is the picture tube. For continued X-RAY RADIATION protection, the replacement tube must be exactly the same type tube as specified in the parts list.
- Some part in this receiver have special safety-related characteristics for X-RAY RADIATION protection. For continued safety, parts replacement should be undertaken only after referring to the PRODUCT SAFETY NOTICE below.

Refer to table-1 for high voltage (A), (B).  
(See SETTING & ADJUSTING DATA on page 17.)

Each time a receiver requires servicing, the high voltage should be checked following the HIGH VOLTAGE CHECK procedure in this manual. It is recommended that the reading of the high voltage be recorded as a part of the service record. It is important to use an accurate and reliable high voltage meter.

### SAFETY PRECAUTION

**WARNING :** Service should not be attempted by anyone unfamiliar with the necessary precautions on this receiver. The following are the necessary precautions to be observed before servicing this chassis.

- An isolation transformer should be connected in the power line between the receiver and the AC line before any service is performed on the receiver.
- Always discharge the picture tube anode to the CRT conductive coating before handling the picture tube. The picture tube is highly evacuated and if broken, glass fragments will be violently expelled. Use shatter proof goggles and keep picture tube away from the unprotected body while handling.
- When replacing a chassis in the cabinet, always be certain that all the protective devices are put back in place, such as; non-metallic control knobs, insulating covers, shields, isolation resistor-capacitor network, etc.
- Before returning the set to the customer, always perform an AC leakage current check on the exposed metallic parts of the cabinet, such as antennas, terminals, screwheads, metal overlays, control shafts, etc. to be sure the set is safe to operate without danger of electrical shock. Plug the AC line cord directly into a 120V AC outlet (do not use a line isolation transformer during this check). Use an AC voltmeter having 5000 ohms per volt or more sensitivity in the following manner:

Connect a 1500 ohm 10 watt resistor, paralleled by a 0.15  $\mu$ F, AC type capacitor, between a known good earth ground (water pipe, conduit, etc.) and the exposed metallic parts, one at a time. Measure the AC voltage across the combination of 1500 ohm resistor and 0.15  $\mu$ F capacitor. Reverse the AC plug at the AC outlet and repeat AC voltage measurements for each exposed metallic part. Voltage measured must not exceed 0.3 volts rms. This corresponds to 0.2 milliamp. AC. Any value exceeding this limit constitutes a potential shock hazard and must be corrected immediately.

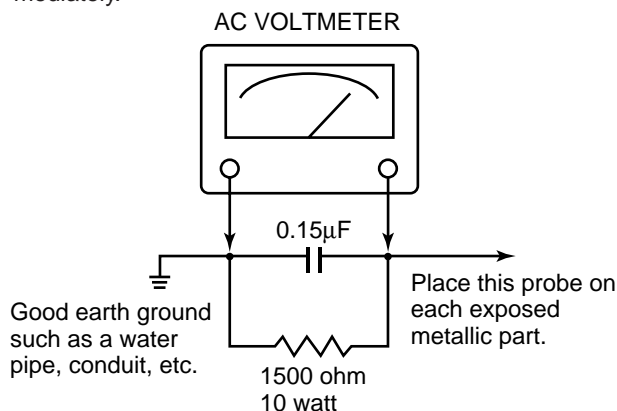

### PRODUCT SAFETY NOTICE

Many electrical and mechanical parts in this chassis have special safety-related characteristics. These characteristics are often passed unnoticed by a visual inspection and the protection afforded by them cannot necessarily be obtained by using replacement components rated for higher voltage, wattage, etc. Replacement parts which have these special safety characteristics are identified in this manual and its supplements; electrical components having such features are identified by the international hazard symbols on the schematic diagram and the parts list.

Before replacing any of these components, read the parts list in this manual carefully. The use of substitute replacement parts which do not have the same safety characteristics as specified in the parts list may create shock, fire, X-ray radiation or other hazards.

**WARNING:** BEFORE SERVICING THIS CHASSIS, READ THE "X-RAY RADIATION PRECAUTION", "SAFETY PRECAUTION" AND "PRODUCT SAFETY NOTICE" ON PAGE 3 OF THIS MANUAL.

## SET-UP ADJUSTMENT (FOR 13", 14", 19", 20")

■ The following adjustments should be made when a complete realignment is required or a new picture tube is installed. Perform the adjustments in order as follows :

1. Color Purity
2. Convergence
3. White Balance

Note: The PURITY/CONVERGENCE MAGNET assembly and rubber wedges need mechanical positioning. Refer to figure 1.

Mounting position of the purity magnet assembly should fit to same position as old one because slightly difference to the position depend on a kind of tube.

\* There are no adjustment of purity and convergence in some picture tube (unified with purity magnet).

### COLOR PURITY ADJUSTMENT

NOTE : Before attempting any purity adjustments, the receiver should be operated for at least fifteen minutes.

1. Demagnetize the picture tube and cabinet using a degaussing coil.
2. Set the brightness and contrast to maximum.
3. Use a green raster from among the built-in test signals.
4. Loosen the clamp screw holding the yoke and slide the yoke backward or forward to provide vertical green belt (zone) in the picture screen.
5. Remove the Rubber Wedges.
6. Rotate and spread the tabs of the purity magnet (See figure 2.) around the neck of the picture tube until the green belt is in the center of the screen. At the same time, enter the raster vertically.
7. Slowly move the yoke forward or backward until a uniform green screen is obtained. Tighten the clamp screw of the yoke temporarily.
8. Check the purity of the red and blue raster.

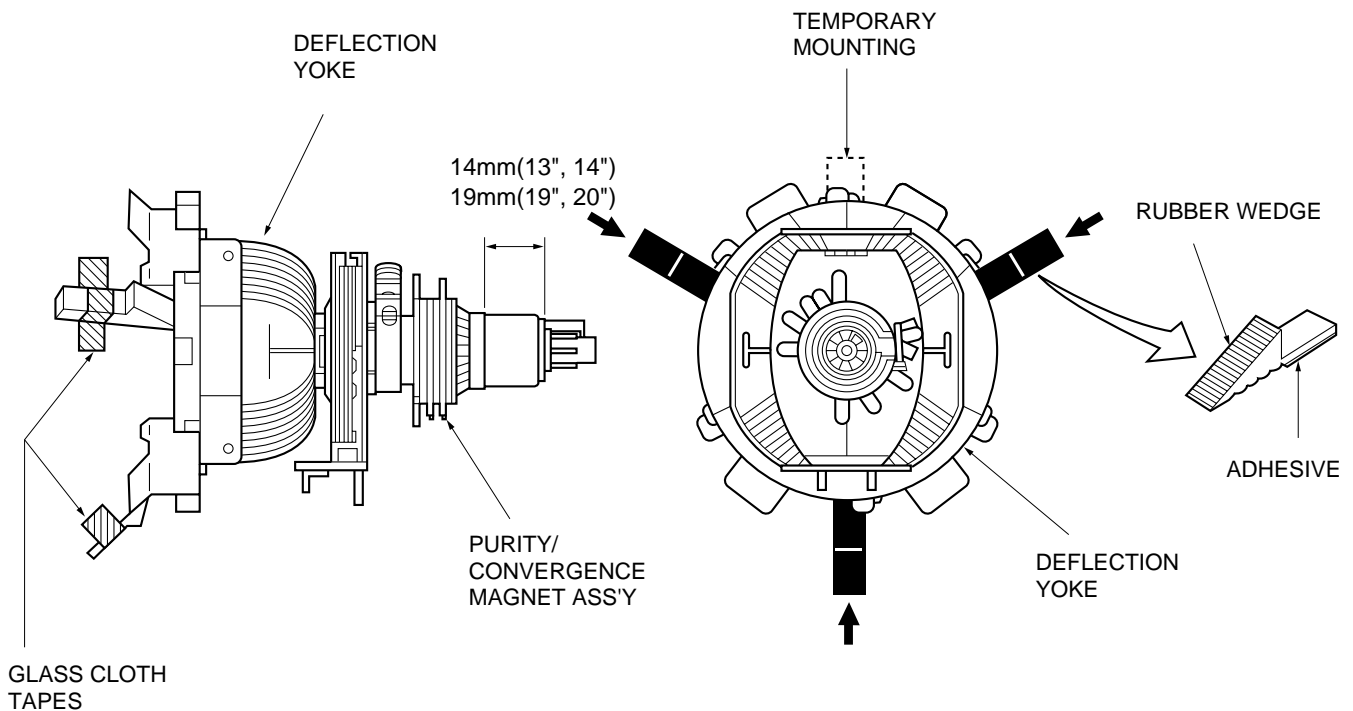

Figure 1.

### CONVERGENCE ADJUSTMENTS

NOTE: Before attempting any convergence adjustments, the receiver should be operated for at least fifteen minutes.

#### ■ CENTER CONVERGENCE ADJUSTMENT

1. Use the cross-dot pattern from among the built-in test signals.
2. Set the brightness and contrast for well defined pattern.
3. Adjust two tabs of the 4-Pole Magnets to change the angle between them (See figure 2.) and superimpose red and blue vertical lines in the center area of the picture screen.
4. Turn the both tabs at the same time keeping the angle constant to superimpose red and blue horizontal lines at the center of the screen.
5. Adjust two tabs of 6-Pole Magnets to superimpose red/blue line and green one. Adjusting the angle affects the vertical lines and rotating both magnets affects the horizontal lines.
6. Repeat adjustments 3, 4, 5 keeping in mind red, green and blue movement, because 4-Pole Magnets and 6-Pole Magnets have mutual interaction and make dot movement complex.

#### ■ CIRCUMFERENCE CONVERGENCE ADJUSTMENT

1. Loosen the clamping screw of deflection yoke slightly to allow the yoke to tilt.
2. Temporarily put a wedge as shown in figure 1. (Do not remove cover paper on adhesive part of the wedge.)
3. Tilt front of the deflection yoke up or down to obtain better convergence in circumference. (See figure 3.) Push the mounted wedge into the space between picture tube and the yoke to fix the yoke temporarily.
4. Put other wedge into bottom space and remove the cover paper to stick.
5. Tilt front of the yoke right or left to obtain better convergence in circumference. (See figure 3.)
6. Keep the yoke position and put another wedge in either upper space. Remove cover paper and stick the wedge on picture tube to fix the yoke.
7. Detach the temporarily mounted wedge and put it in another upper space. Stick it on picture tube to fix the yoke.
8. After fixing three wedges, recheck overall convergence. Tighten the screw firmly to fix the yoke and check the yoke is firm.
9. Stick three adhesive tapes on wedges as shown in figure 1.

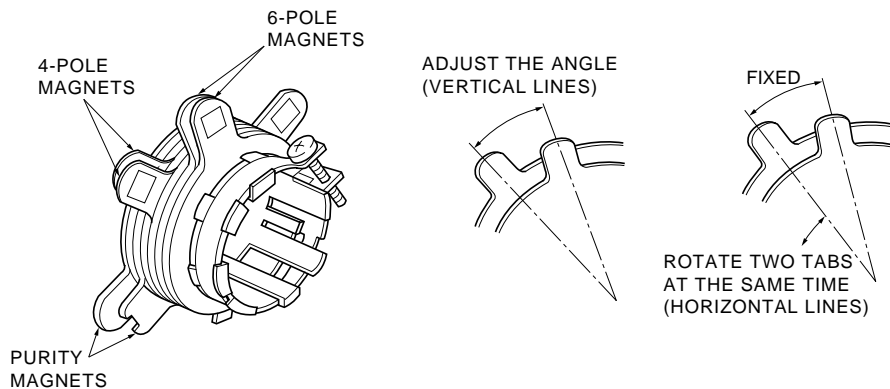

CONVERGENCE MAGNET ASSEMBLY

ADJUSTMENT OF MAGNETS

Figure 2.

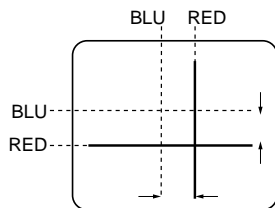

4-POLE MAGNETS MOVEMENT

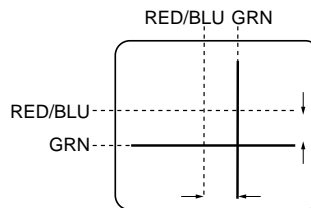

6-POLE MAGNETS MOVEMENT

Center Convergence by Convergence Magnets

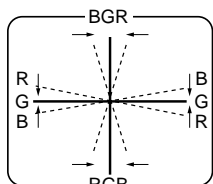

INCLINE THE YOKE UP (OR DOWN)

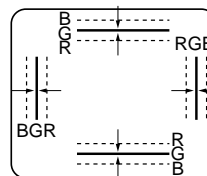

INCLINE THE YOKE RIGHT (OR LEFT)

Circumference Convergence by DEF Yoke

Figure 3. Dot Movement Pattern

**WARNING:** BEFORE SERVICING THIS CHASSIS, READ THE "X-RAY RADIATION PRECAUTION", "SAFETY PRECAUTION" AND "PRODUCT SAFETY NOTICE" ON PAGE 3 OF THIS MANUAL.

**(FOR 35", 36")**

■ The following adjustments should be made when a complete realignment is required or a new picture tube is installed. Perform the adjustments in order as follows :

1. Color Purity
2. Convergence
3. White Balance

Note: The PURITY/CONVERGENCE MAGNET assembly and rubber wedges need mechanical positioning. Refer to figure 1.

Mounting position of the purity magnet assembly should fit to same position as old one because slightly difference to the position depend on a kind of tube.

■ There are no adjustment of purity and convergence in some picture tube (unified with purity magnet).

**COLOR PURITY ADJUSTMENT**

NOTE : Before attempting any purity adjustments, the receiver should be operated for at least fifteen minutes.

1. Evenly degauss the entire screen.
2. Set the CONTRAST and BRIGHTNESS Controls to the maximum.
3. Display built-in green raster using the TEST SIGNAL SELECTION function.
4. Loosen the clamp screw holding the deflection yoke (and remove the Rubber Wedges).
5. Slide the yoke forward or backward to provide vertical green belt (zone) in the picture screen.
6. Rotate and spread the tabs of the purity magnet (See figure 4.) around the neck of the picture tube until the green belt is in the center of the screen. At the same time, center the raster vertically by adjusting the magnet as shown below.

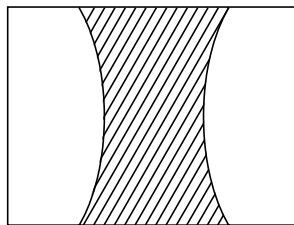

Green Belt

7. Move the yoke slowly forward or backward until a uniform green screen is obtained. Tighten the clamp screw of the yoke temporarily.
8. Check the purity of the red and blue raster.
9. Put four wedges into the space between the picture tube and the yoke to hold the yoke in the adjusted position. (See figure 2.) Do not tilt the yoke by excessive insertion of the wedge.
10. Remove cover paper of wedge and stick wedges on the tube to fix the yoke in the adjusted position. Fix the wedges with glass cloth tapes.

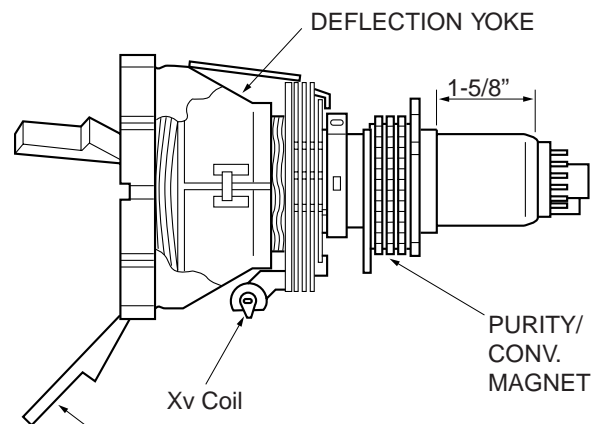

Figure 1.

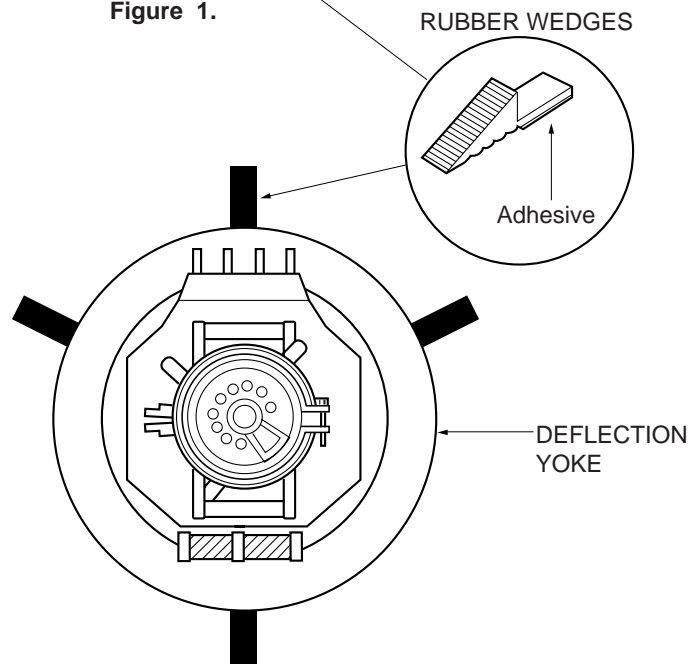

Figure 2.

**CONVERGENCE ADJUSTMENTS**

NOTE: Before attempting any convergence adjustments, the receiver should be operated for at least fifteen minutes.

■ **CENTER CONVERGENCE ADJUSTMENT**

1. Display built-in cross-dot pattern using the TEST SIGNAL SELECTION function.
2. Adjust the BRIGHTNESS and CONTRAST Controls for well defined pattern.
3. Loosen the tightening ring and adjust two tabs of the 4-Pole Magnets to change the angle between them (See figure 4.) and superimpose red and blue vertical lines in the center area of the picture screen. (See figure 3.)
4. Turn the both tabs at the same time keeping the constant angle to superimpose red and blue horizontal lines at the centre of the screen. (See figure 3.)
5. Adjust two tabs of 6-Pole Magnets to superimpose red/blue line with green one. Adjusting the angle affects the vertical lines and rotating both magnets affects the horizontal lines.
6. Repeat adjustments 3, 4, 5 keeping in mind red, green and blue movement, because 4-Pole Magnets and 6-Pole magnets interact and make dot movement complex.
7. After completing the "CENTER CONVERGENCE ADJUSTMENT", tighten the tightening ring to fix the magnets.

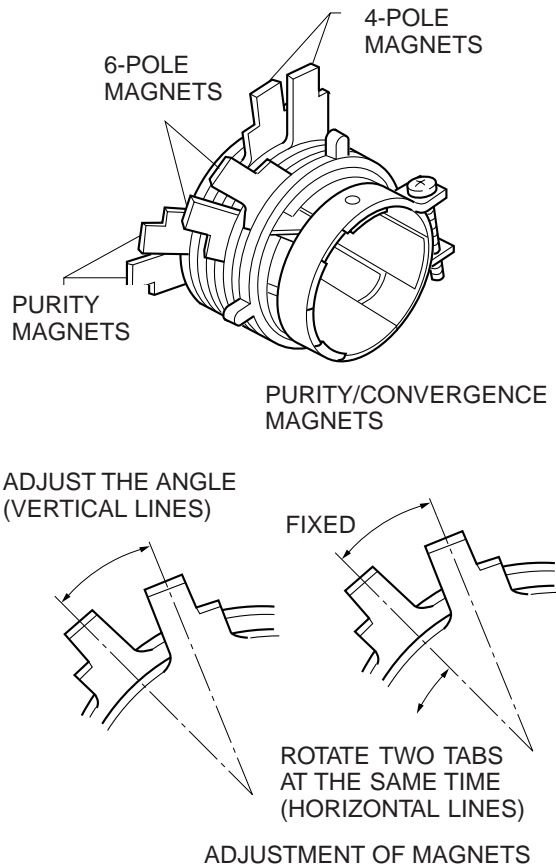
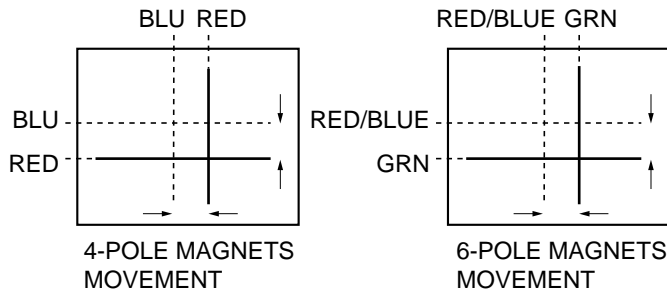

Figure 4.



Center Convergence by Convergence Magnets

Figure 3.

■ **Xv COIL ADJUSTMENT**

Adjust the Xv coil (on the deflection yoke) to correct misconvergence at both sides on screen. Use a hexagonal tip stick (plastic) to adjust the core of coil.

**Clockwise Adjustment      Counterclockwise Adjustment**

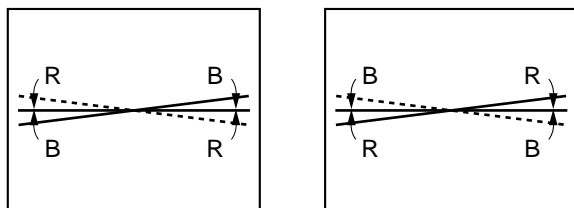

Xv Cross Pattern View

■ **SCREEN-CORNER CONVERGENCE**

When the misconvergence is still evident on corners even though the above adjustment is done, use the ferrite sheet (Part No. 23993622) to correct misconvergence.

1. Put ferrite sheets into the space under the yoke. Decide such position that misconvergence becomes minimum, watching picture screen. (See figure below.)
2. Remove cover paper of ferrite sheet to stick it in the place on the tube. Put adhesive tapes on ferrite sheets to fix.

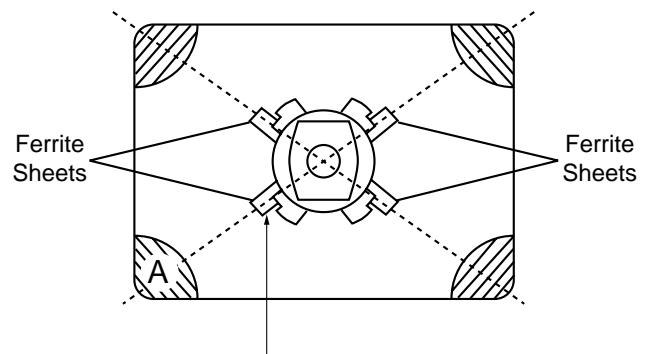

For correcting misconvergence on the position A

## SERVICE MODE

### 1. ENTERING TO SERVICE MODE

- 1) Press MUTE button once on Remote Control.
- 2) Press MUTE button again to keep pressing.
- 3) While pressing the MUTE button, press MENU button on TV set.



### 2. DISPLAYING THE ADJUSTMENT MENU

- 1) Press MENU button on TV.

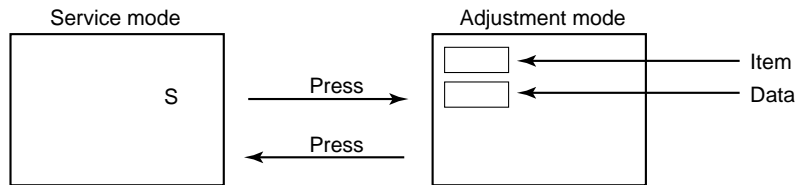

### 3. KEY FUNCTION IN THE SERVICE MODE

The following key entry during display of adjustment menu provides special functions.

A single horizontal line ON/OFF:	TV (ANT)/VIDEO button (on TV)
Test signal selection :	TV (ANT)/VIDEO button (on Remote)
Selection of the adjustment items :	Channel ▲/▼ (on TV or Remote)
Change of the data value :	Volume ▲/▼ (on TV or Remote)
Adjustment menu mode ON/OFF :	MENU button (on TV)
Initialization of the memory (QA02) :	RECALL+Channel (▲) button on TV
Initialization of the self diagnostic data:	RECALL+Channel (▼) button on TV
"RCUT" selection :	1 button
"GCUT" selection :	2 button
"BCUT" selection :	3 button
"CNTX" selection :	4 button
"COLC" selection :	5 button
"TNTC" selection :	6 button
Test audio signal ON/OFF (1kHz) :	8 button
Self diagnostic display ON/OFF :	9 button

#### 4. SELECTING THE ADJUSTING ITEMS

- 1) Every pressing of CHANNEL ▲ button in the service mode changes the adjustment items in the order of table-2. (▼ button for reverse order)

Refer to table-2 for preset data of adjustment mode.  
(See SETTING & ADJUSTING DATA on page 17.)

#### 5. ADJUSTING THE DATA

- 1) Pressing of VOLUME ▲ or ▼ button will change the value of data in the range from 00H to FFH. The variable range depends on the adjusting item.

#### 6. EXIT FROM SERVICE MODE

- 1) Pressing POWER button to turn off the TV once.

#### ■ INITIALIZATION OF MEMORY DATA OF QA02

After replacing QA02, the following initialization is required.

1. Enter the service mode, then select any register item.
2. Press and hold the RECALL button on the Remote, then press the CHANNEL ▲ button on the TV. The initialization of QA02 has been completed.
3. Check the picture carefully. If necessary, adjust any adjustment item above. Perform "Programming Channel Memory" on the owner's manual.

CAUTION: Never attempt to initialize the data unless QA02 has been replaced.

#### 7. TEST SIGNAL SELECTION

- 1) Every pressing of TV/VIDEO button on the Remote Control in the service mode changes the built-in test patterns on screen in the following order.

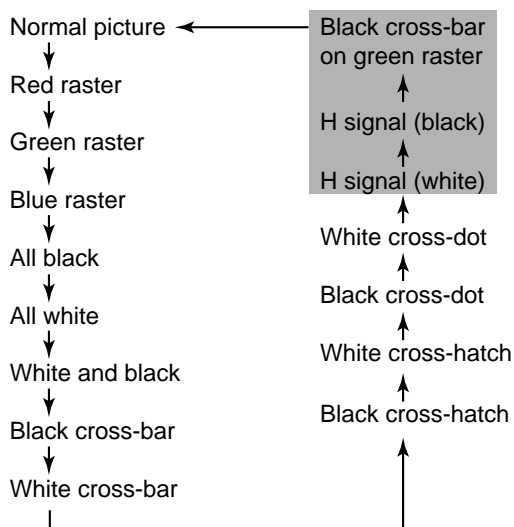

- 2) Press "8" button while any built-in test pattern to on the screen to output the 1 kHz sound. Press the button again to cut off the sound.

Note: If the video cable is connected to the VIDEO1 INPUT jack, the built-in pattern signals are not displayed.

Signals	Picture
<ul style="list-style-type: none"> <li>• Red raster</li> <li>• Green raster</li> <li>• Blue raster</li> <li>• All Black</li> <li>• All White</li> </ul>	
<ul style="list-style-type: none"> <li>• Black &amp; White</li> </ul>	
<ul style="list-style-type: none"> <li>• Black cross-bar</li> <li>• White cross-bar</li> <li>• Black cross-bar on green raster</li> </ul>	
<ul style="list-style-type: none"> <li>• Black cross-hatch</li> <li>• White cross-hatch</li> </ul>	
<ul style="list-style-type: none"> <li>• Black cross-dot</li> <li>• White cross-dot</li> </ul>	
<ul style="list-style-type: none"> <li>• H signal (white)</li> <li>• H signal (black)</li> </ul>	

\*The signals marked with ■ are not usable to display in the test signal for some model.



# DESIGN MODE

## 1. ENTERING TO DESIGN MODE

- 1) Select the Service mode.
- 2) While pressing RECALL button on Remote and press MENU button on TV.
- 3) Press MENU button on TV.

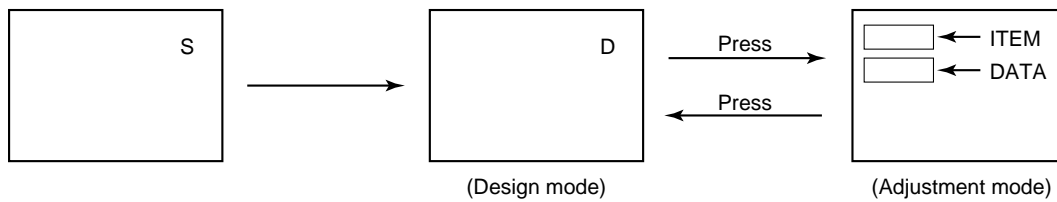

When QA02 is initialized, items "OPT0" and "OPT1" of DESIGN MODE are set to the data of the representative model of this chassis family.

Therefore, because ON-SCREEN specification remains in the state of the representative of model. This model is required to reset the data of items "OPT0" and "OPT1".

## 2. SELECTING THE ADJUSTING ITEMS

Every pressing of CHANNEL ▼ button in the design mode changes the adjustment items in the order of table-3. (▲ button for reverse order)

Refer to table-3 for data of design mode.  
(See SETTING & ADJUSTING DATA on page 17.)

## 3. ADJUSTING THE DATA

Pressing of VOLUME ▲ or ▼ button will change the value of data.

## ELECTRICAL ADJUSTMENTS

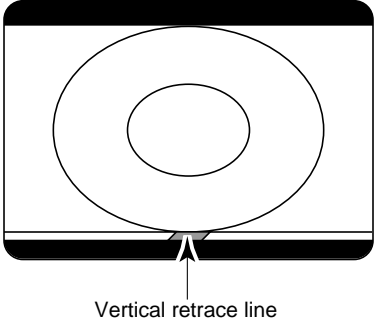
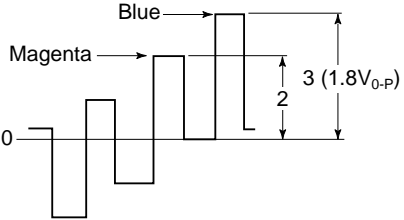
ITEM	ADJUSTMENT PROCEDURE	
FOCUS VR ADJ	<ol style="list-style-type: none"> <li>1. Enter the service mode, then select any register item.</li> <li>2. Press the TV/VIDEO button on the Remote until the black cross-bar pattern appears on the screen.</li> <li>3. Adjust the FOCUS control (on T461) for well defined scanning lines on the picture screen.</li> </ol>	
SUB-BRIGHTNESS (BRTC)	<ol style="list-style-type: none"> <li>1. Constrict the picture height until the vertical retrace line appears adjusting the HEIGHT control on the MAIN board.</li> <li>2. Adjust the CONTRAST to the minimum and BRIGHTNESS to the center.</li> <li>3. Enter the service mode, then select "BRTC" register.</li> <li>4. Adjust the data value so the belt of vertical retrace line just disappear.</li> <li>5. Adjust the CONTRAST for the desired contrast.</li> <li>6. Adjust the HEIGHT control.</li> </ol>	
SUB-COLOR (COLC) SUB-TINT (TNTC)	<ol style="list-style-type: none"> <li>1. Receive color-bar signal from color-bar generator.</li> <li>2. Press the RESET button.</li> <li>3. Connect oscilloscope to base of Q906 on CRT-D board.</li> <li>4. Enter the service mode, then select "COLC".</li> <li>5. Adjust the SUB-COLOR by pressing the VOLUME ▲ or ▼ button to achieve about <math>1V_{0-p}</math> of blue bar.</li> <li>6. Select "TNTC" register.</li> <li>7. Adjust the data value to obtain the blue bar to magenta bar ratio of 3:2 as shown.</li> <li>8. Select "COLC" register.</li> <li>9. Adjust the data value to achieve <math>1.8V_{0-p}</math> of blue bar on scope.</li> <li>10. Check the picture with off-air signal.</li> </ol>	
WIDTH (WID)	<ol style="list-style-type: none"> <li>1. Call up the adjustment mode display, then select the item <b>WID</b>.</li> <li>2. Press the VOLUME ▲ or ▼ button to get the picture so the left and right edges of raster begins to lack.</li> <li>3. Press the VOLUME ▲ or ▼ button to advance the data by 7 steps.</li> </ol> <p>Note : Check the horizontal picture position is correct.</p>	

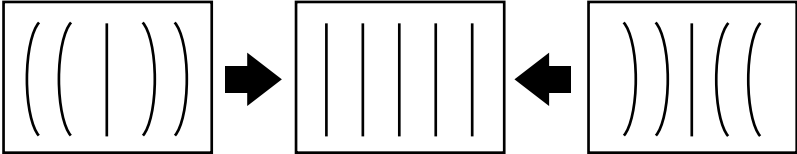
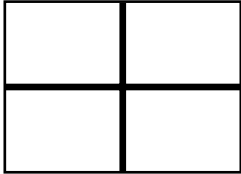
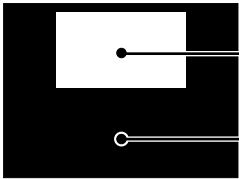
ITEM	ADJUSTMENT PROCEDURE
<p>E-W PARABOLA (DPC)</p>	<ol style="list-style-type: none"> <li>1. Call up the adjustment mode display, then select the item <b>DPC</b>.</li> <li>2. Press the TV/VIDEO button on Remote until the cross-hatch pattern appears on the screen.</li> <li>3. Press the VOLUME ▲ or ▼ button to make vertical lines straight as shown below.</li> </ol> <div style="text-align: center;">  </div>
<p>HORIZONTAL POSITION (HPOS) VERTICAL POSITION (VPOS)</p>	<ol style="list-style-type: none"> <li>1. Call up the adjustment mode display, then select the item <b>HPOS</b> or <b>VPOS</b>.</li> <li>2. Press the TV/VIDEO button on Remote until the white cross-bar or black cross-bar pattern appears on the screen.</li> <li>3. Adjust the HORIZONTAL and VERTICAL position alternately by pressing the VOLUME ▲ or ▼ button for proper picture position.</li> <li>4. Check the picture with off-air signal.</li> </ol> <div style="text-align: right;">  </div>
<p>HEIGHT (HIT)</p>	<ol style="list-style-type: none"> <li>1. Call up the adjustment mode display, then select the item <b>HIT</b>.</li> <li>2. Press the VOLUME ▲ or ▼ button to get the picture so the top of raster begins to lack.</li> <li>3. Press the VOLUME ▲ button to advance the data by 8 steps.</li> </ol> <p>Note : Check the vertical picture position is correct.</p>
<p>WHITE BALANCE (RCUT) (GCUT) (BCUT) (GDRV) (BDRV)</p>	<ol style="list-style-type: none"> <li>1. Adjust the CONTRAST control to the center, and BRIGHTNESS control to the maximum.</li> <li>2. Call up the adjustment mode display, and press the TV/VIDEO button on Remote until the white and black pattern appears on the screen.</li> <li>3. Adjust the following item with the CHANNEL ▲/▼ and VOLUME ▲/▼ buttons. <ul style="list-style-type: none"> <li>RCUT → Data : 40H</li> <li>GCUT → Data : 40H</li> <li>BCUT → Data : 40H</li> <li>GDRV → Data : 40H</li> <li>BDRV → Data : 40H</li> </ul> </li> <li>4. Press the TV/VIDEO button on TV to display a single horizontal line on the screen.</li> <li>5. Turn the SCREEN control (FBT) fully counterclockwise and gradually rotate clockwise until the first horizontal line appears slightly on the screen.</li> <li>6. Press the TV/VIDEO button to display the normal picture.</li> <li>7. Adjust the remaining two “?CUT” items (CHANNEL ▲/▼ → TV/VIDEO → VOLUME ▲/▼ in order) to obtain the slightly lighted horizontal line in the same levels of three (red, green, blue) colors. The line should be white if the adjustments are proper.</li> </ol> <div style="margin-top: 20px;">  <div style="margin-left: 10px;"> <p>Bright area Adjust "GDRV" or "BDRV" to be white.</p> <p>Dark area Fine adjust "RCUT", "GCUT" or "BCUT" to be black.</p> </div> </div>

## MTS ADJUSTMENT (FOR N5ES/N7S CHASSIS)

No.	ITEM	INPUT SIGNAL	ADJUSTMENT PROCEDURE
1	ATTENUATOR (ATT)	<ul style="list-style-type: none"> <li>1kHz 30% mod. → ANT terminal</li> </ul>	<ol style="list-style-type: none"> <li>1. Connect rms meter to pin 12 of H002.</li> <li>2. Display item <b>ATT</b> on screen.</li> <li>3. Change data by VOLUME ▲/▼ buttons so that output at pin 12 of H002 becomes value as close as 142mVrms.</li> </ol>
2	STEREO VCO (STVC)	<ul style="list-style-type: none"> <li>No signal</li> </ul>	<ol style="list-style-type: none"> <li>1. Display item <b>STVC</b>, and connect pin 9 of H002 to ground.</li> <li>2. Connect frequency counter to pin 12 of H002.</li> <li>3. Change data by VOLUME ▲/▼ buttons so that the reading of counter becomes value as close as 4fH (62.936kHz).</li> </ol>
3	SAP VCO (SAVC)	<ul style="list-style-type: none"> <li>78.670kHz 147mVrms → pin 9 of H002</li> <li>Monaural signal → ANT</li> </ul>	<ol style="list-style-type: none"> <li>1. Display item <b>SAVC</b>.</li> <li>2. Change data by VOLUME ▲/▼ buttons so that the data becomes in the center of range for STA7=0 and STA8=1.</li> </ol> <div style="border: 1px solid black; padding: 5px; margin: 10px auto; width: fit-content;"> <p style="text-align: center;">SAVC XXH STA7:0 STA8:1</p> </div>
4	STEREO FILTER (STRF)	<ul style="list-style-type: none"> <li>9.4kHz 600mVrm → pin 9 of H002</li> <li>Monaural signal → ANT</li> </ul>	<ol style="list-style-type: none"> <li>1. Display item <b>STRF</b> on screen.</li> <li>2. Change data by VOLUME ▲/▼ buttons so that the data becomes in the center of range for STA3=1.</li> </ol> <div style="border: 1px solid black; padding: 5px; margin: 10px auto; width: fit-content;"> <p style="text-align: center;">STRF XXH STA3:1</p> </div>
5	SAP FILTER (SAPF)	<ul style="list-style-type: none"> <li>88kHz 120mVrms → pin 9 of H002</li> <li>Monaural signal → ANT</li> </ul>	<ol style="list-style-type: none"> <li>1. Display item <b>SAPF</b>.</li> <li>2. Change data by VOLUME ▲/▼ buttons so that the data becomes in the center of range for STA4=1.</li> </ol> <div style="border: 1px solid black; padding: 5px; margin: 10px auto; width: fit-content;"> <p style="text-align: center;">SAPF XXH STA4:1</p> </div>
6	STEREO SEPARATION (WBAN)	<ul style="list-style-type: none"> <li>STEREO 300Hz R-channel only → ANT</li> </ul>	<ol style="list-style-type: none"> <li>1. Select "STEREO" mode from the MTS function in the Audio menu.</li> <li>2. Display item <b>WBAN</b> on screen.</li> <li>3. Connect oscilloscope to pin 14 of H002.</li> <li>4. Change data by VOLUME ▲/▼ buttons so that 300Hz element on scope becomes minimum.</li> </ol>
	(SPEC)	<ul style="list-style-type: none"> <li>STEREO 3kHz R-channel only → ANT</li> </ul>	<ol style="list-style-type: none"> <li>5. Display item <b>SPEC</b> on screen.</li> <li>6. Change data by VOLUME ▲/▼ buttons so that 3kHz element on scope becomes minimum.</li> </ol>

**MTS ADJUSTMENT (FOR N0ES CHASSIS)**

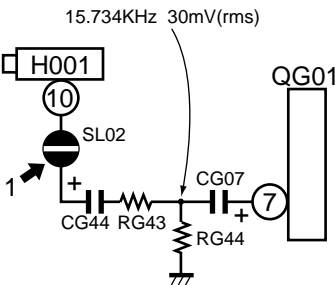
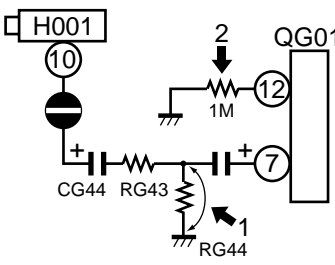
No.	ITEM	INPUT SIGNAL	ADJUSTMENT PROCEDURE
1	ATTENUATOR (ATT)	<ul style="list-style-type: none"> <li>1kHz 30% mod. → ANT terminal</li> </ul>	<ol style="list-style-type: none"> <li>1. Connect rms meter to pin 34 of QG01.</li> <li>2. Display item <b>ATT</b> on screen.</li> <li>3. Change data by VOLUME ▲/▼ buttons so that the reading of meter becomes value as close as 137mVrms.</li> </ol>
2	STEREO VCO (STVC)	<ul style="list-style-type: none"> <li>No signal</li> </ul>	<ol style="list-style-type: none"> <li>1. Short circuit RG44 with a jumper wire.</li> <li>2. Display item <b>STVC</b> on screen.</li> <li>3. Connect frequency counter to pin 34 of QG01.</li> <li>4. Change data by VOLUME ▲/▼ buttons so that the reading of counter becomes value as close as 15.73kHz.</li> </ol>
3	STEREO FILTER (STRF)	<ul style="list-style-type: none"> <li>15.734kHz 30mV(rms)</li> </ul> 	<ol style="list-style-type: none"> <li>1. Unsolder the solder link SL02.</li> <li>2. Display item <b>STRF</b> on screen.</li> <li>3. Connect oscilloscope to pin 34 of QG01.</li> <li>4. Change data by VOLUME ▲/▼ buttons to minimize AC output level on scope.</li> <li>5. Resolder SL02.</li> </ol>
4	STEREO SEPARATION (WBAN)	<ul style="list-style-type: none"> <li>STEREO 300Hz R-channel only → ANT</li> </ul>	<ol style="list-style-type: none"> <li>1. Display item <b>WBAN</b> on screen.</li> <li>2. Connect oscilloscope to pin 35 of QG01.</li> <li>3. Change data by VOLUME ▲/▼ buttons so that 300Hz element on scope becomes minimum.</li> </ol>
	(SPEC)	<ul style="list-style-type: none"> <li>STEREO 3kHz R-channel only → ANT</li> </ul>	<ol style="list-style-type: none"> <li>4. Display item <b>SPEC</b> on screen.</li> <li>5. Change data by VOLUME ▲/▼ buttons so that 3kHz element on scope becomes minimum.</li> </ol>
5	SAP VCO (SAVC)	<ul style="list-style-type: none"> <li>No signal</li> </ul> 	<ol style="list-style-type: none"> <li>1. Shortcircuit RG44 with a short jumper.</li> <li>2. Connect 1Mohm resistor between pin 12 of QG01 and ground.</li> <li>3. Display item <b>SAVC</b> on screen.</li> <li>4. Connect frequency counter to pin 34 of QG01.</li> <li>5. Change data by VOLUME ▲/▼ buttons so that the reading of counter becomes value as close as 78.67kHz.</li> <li>6. Remove the short jumper and 1M ohm resistor.</li> </ol>

## CIRCUIT CHECKS

### HIGH VOLTAGE CHECK

**CAUTION:** There is no HIGH VOLTAGE ADJUSTMENT on this chassis. Checking should be done following the steps below.

1. Connect an accurate high voltage meter to the second anode of the picture tube.
2. Turn on the receiver. Set the BRIGHTNESS and CONTRAST controls to minimum (zero beam current).
3. High voltage must be measured below (B) kV.

Refer to table-1 for high voltage (B).  
(See SETTING & ADJUSTING DATA on page 17.)

4. Vary the BRIGHTNESS control to both extremes to be sure the high voltage does not exceed the limit under any conditions.

### FS CIRCUIT CHECK

The Fail Safe (FS) circuit check is indispensable for the final check in servicing. Checking should be done following the steps below.

1. Turn the receiver on and press the RESET button.
2. Temporarily short TP-(R) and TP-(X) with a jumper wire. Raster and sound will disappear.
3. The receiver must remain in this state even after removing the jumper wire. This is the evidence that the FS circuit is functioning properly.
4. To obtain a picture again, temporarily turn the receiver off and allow the FS circuit more than 5 seconds to reset. Then turn the power switch on to produce a normal picture.

### Troubleshooting Guide for Fail Safe Circuit

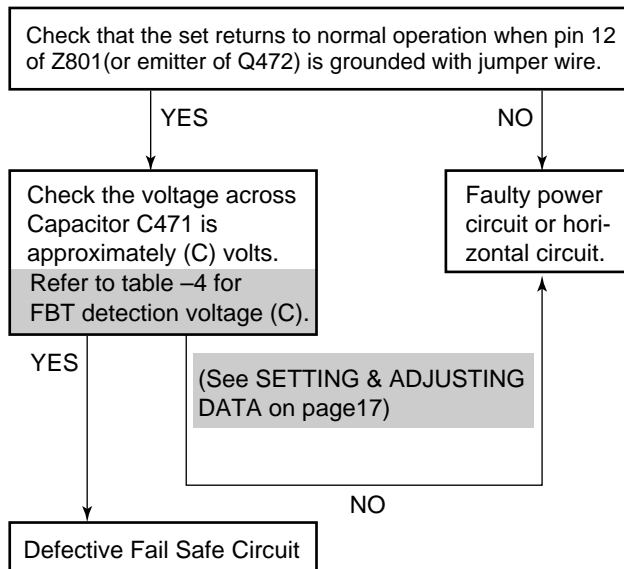

## CHAPTER 2 SPECIFIC INFORMATIONS

### SETTING & ADJUSTING DATA

#### 【 SAFETY INSTRUCTIONS 】

		27"
HIGH VOLTAGE AT ZERO BEAM:	(A)	28.3kV
MAX HIGH VOLTAGE:	(B)	29.7 kV

Table-1

#### 【 SERVICE MODE 】

##### ADJUSTING ITEMS AND DATA IN THE SERVICE MODE:

Item	Name of adjustment	Preset	Data	Item	Name of adjustment	Preset	Data
RCUT	R CUTOFF	40H	←	VPOS	VERT. POSITION	03H	←
GCUT	G CUTOFF	40H	←	HIT	HEIGHT	1EH	18H
BCUT	B CUTOFF	40H	←	LIN	V-LINEARITY	06H	←
GDRV	G DRIVE	40H	←	VSC	V-S CORRECTION	04H	03H
BDRV	B DRIVE	40H	←	WID	PICTURE WIDTH	18H	←
SCNT	SUB-CONTRAST	08H	←	DPC	E-W PARABOLA (DPC)	0AH	←
BRTC	SUB-BRIGHT	40H	←	CNR	E-W CORNER	07H	←
COLC	SUB-COLOR	40H	←	TRAP	TRAPEZIUM	09H	←
TNTC	SUB-TINT	40H	←	PCOL	PIP COLOR	91H	←
SAVC	SAP VCO	20H	←	PHUE	PIP TINT	09H	←
ATT	ATTENUATOR	20H	←	VPS	V-SHIFT	1BH	←
STVC	STEREO VCO	20H	←	VCP	V-COMPENSATION	03H	←
STRF	STEREO FILTER	20H	←	HCP	H-COMPENSATION	00H	←
SPEC	SPECTRAL	20H	←	VFC	V-F CORRECTION	0FH	←
WBAN	STEREO SEPARATION	20H	←	DAC	DAC	03H	←
HPOS	HORIZ. POSITION	16H	←	PBRT	-	0DH	←

Table-2

#### 【 DESIGN MODE 】

##### ADJUSTING ITEMS AND DATA IN THE DESIGN MODE:

Item	Name of adjustment	Data		Remarks
		Preset Data	27"	
OPT0	OPTION 0	20H	20H	
OPT1	OPTION 1	80H	84H	

Table-3

#### 【 CIRCUIT CHECKS 】

FBT DETECTION VOLTAGE	(C)	21.87V
-----------------------	-----	--------

Table-4

# LOCATION OF CONTROLS

Front view

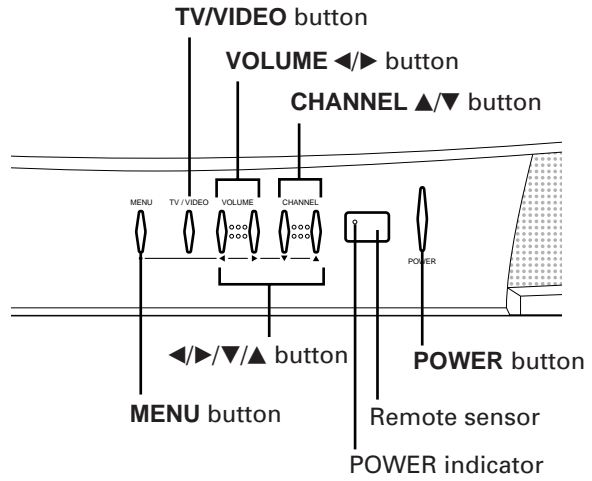
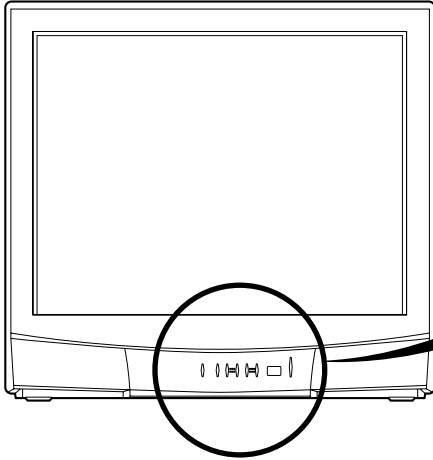

Rear view

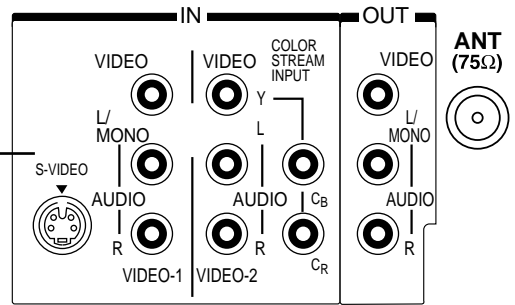
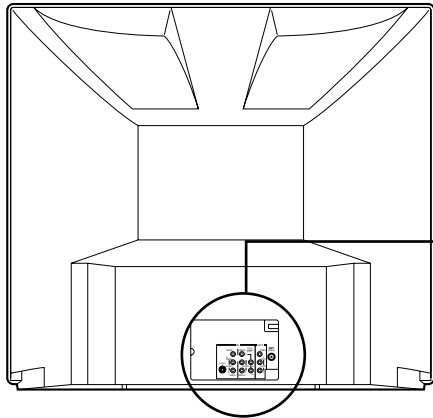

Remote

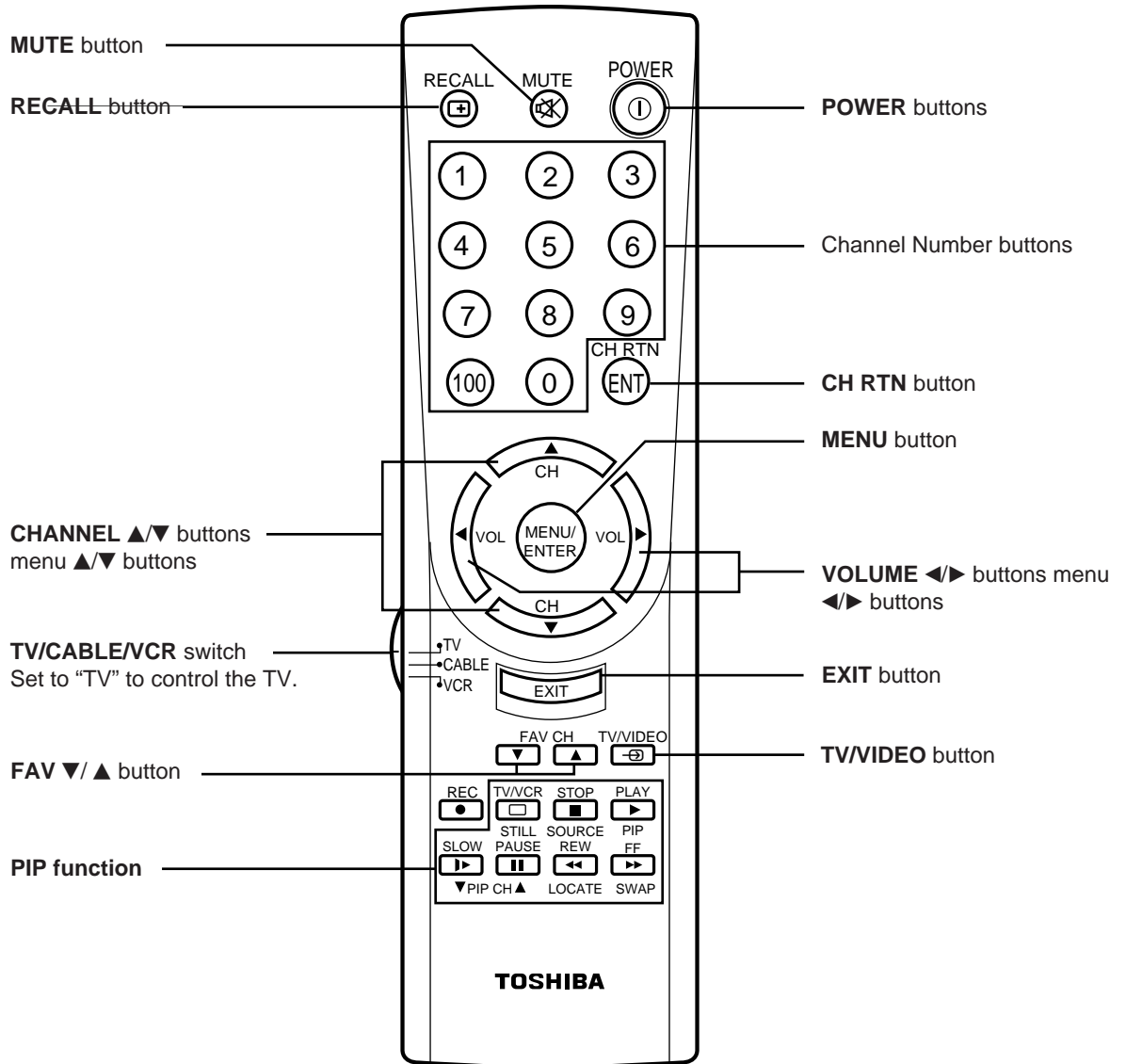

## PROGRAMMING CHANNEL MEMORY

The channel memory is a list of TV channel numbers your TV will stop on when you press the CHANNEL ▲ or ▼ button.

**First, use the TV/CABLE and CH PROGRAM functions to preset all active channels in your area.**

If necessary, arrange the preset channels with the ADD/ERASE functions so that you can tune into only desired channels.

### TV/CABLE function

- 1 Press **POWER** to turn on the TV.
- 2 Press **MENU** repeatedly until the Setup menu is displayed on the screen.
- 3 Press ▼ or ▲ repeatedly until “TV/CABLE” is displayed in purple.
- 4 Press ◀ or ▶ until the mode that corresponds to your TV signal system is displayed in purple.  
**TV:** TV broadcasts signals.  
(VHF channels 2 through 13 and UHF channels 14 through 69)  
**CABLE:** Cable TV signals.  
(Cable channels 1 through 125)

### CH PROGRAM function

- 1 Press **MENU** repeatedly until the Setup menu is displayed on the screen.
- 2 Press ▲ or ▼ repeatedly until “CH PROGRAM” is displayed in purple.
- 3 Press ◀ or ▶ to start channel programming.  
The TV will automatically cycle through all the TV or CABLE channels depending on the mode selected, and store active channels in the channel memory.
- 4 When channel programming is complete, you will see the message on the screen.
- 5 Press **CHANNEL ▲** or **▼** to make sure the channel programming has been done properly.

### ADD/ERASE function

After performing the CH PROGRAM function, you can add or erase specific channels.

- 1 Select the channel you want to erase using the **CHANNEL ▲** or **▼** button, or select the channel you want to add using the **Channel Number** buttons.
- 2 Press **MENU** repeatedly until the Setup menu is displayed on the screen.
- 3 Press ▼ or ▲ repeatedly until “ADD/ERASE” is displayed in purple.
- 4 Press ◀ or ▶ :  
**To erase the channel**  
Press the button until “ERASE” is displayed in purple indicating that the channel has been erased from the memory.  
  
**To add the channel**  
Press the button until “ADD” is displayed in purple indicating that the channel has been memorized.
- 5 Repeat steps 1 to 4 for other channels.

You have now completed the channel programming.

\*Please refer to owner's manual in detail.

# CIRCUIT BLOCK DIAGRAM

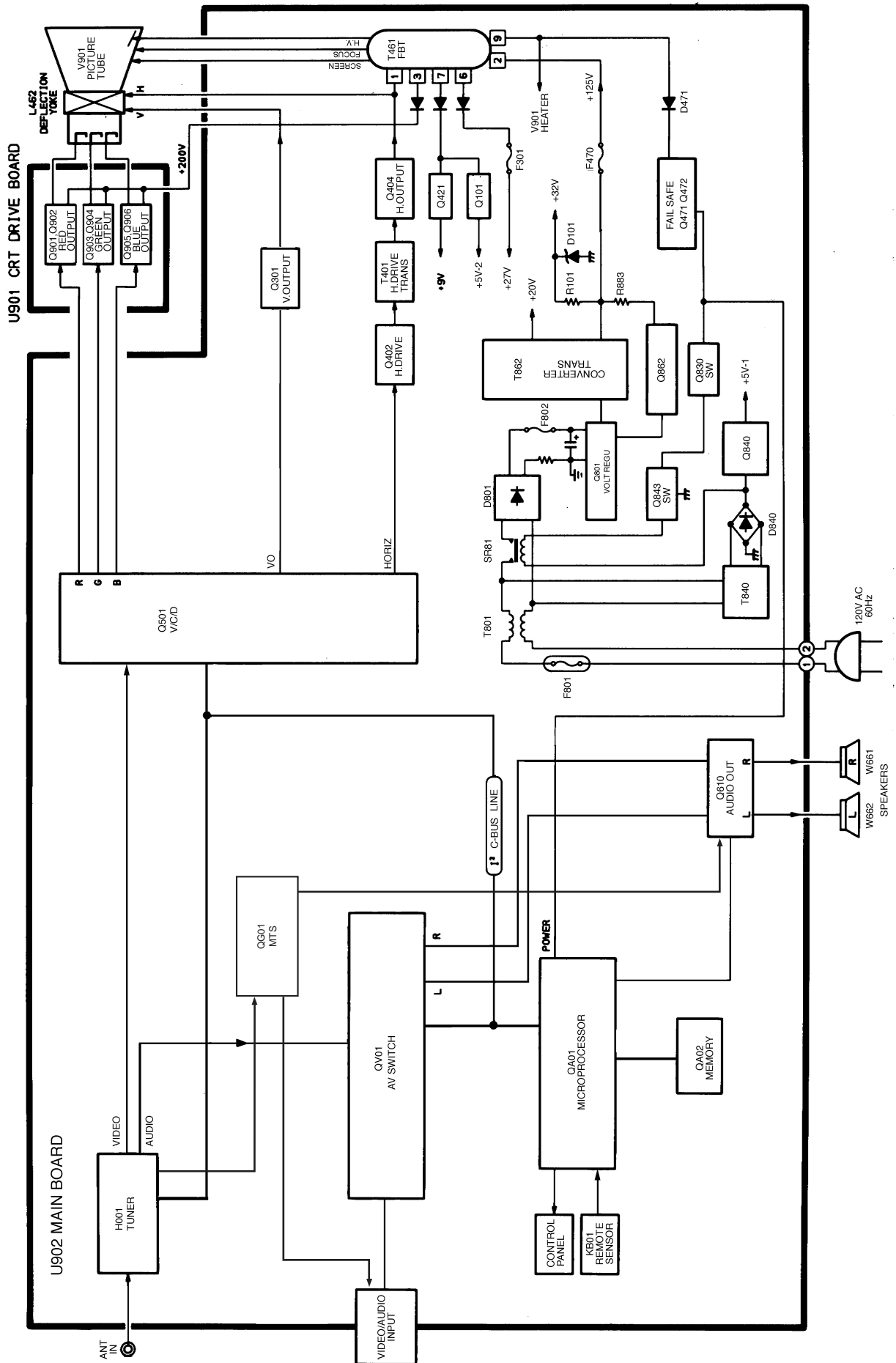

# CHASSIS AND CABINET REPLACEMENT PARTS LIST

**WARNING:** BEFORE SERVICING THIS CHASSIS, READ THE "X-RAY RADIATION PRECAUTION", "SAFETY PRECAUTION" AND "PRODUCT SAFETY NOTICE" ON PAGE 3 OF THIS MANUAL.

**CAUTION:** The international hazard symbols "⚠" in the schematic diagram and the parts list designate components which have special characteristics important for safety and should be replaced only with types identical to those in the original circuit or specified in the parts list. The mounting position of replacements is to be identical with originals. Before replacing any of these components, read carefully the PRODUCT SAFETY NOTICE. Do not degrade the safety of the receiver through improper servicing.

**NOTICE:**

- The part number must be used when ordering parts, in order to assist in processing, be sure to include the Model number and Description.
- The PC board assembly with \* mark is no longer available after the end of the production.

**Model : 27A50**

Capacitors .....	CD : Ceramic Disk	PF : Plastic Film	EL : Electrolytic
Resistors .....	CF : Carbon Film	CC : Carbon Composition	MF : Metal Film
	OMF : Oxide Metal Film	VR : Variable Resistor	FR : Fusible Resistor

(All CD and PF capacitors are ±5%, 50V and all resistors, ±5%, 1/6W unless otherwise noted.)

SPECIFIC INFORMATIONS

Location No.	Part No.	Description
<b>CAPACITORS</b>		
C102	24793101	EL, 100µF, ±20%, 10V
C105	24212102	CD, 1000pF, ±10%
C106	24797479	EL, 4.7µF, ±20%, 50V
C107	24763221	EL, 220µF, ±20%, 16V
C201	24539104	PF, 0.1µF
C204	24797010	EL, 1µF, ±20%, 50V
C205	24794100	EL, 10µF, ±20%, 16V
C216	24797100	EL, 10µF, ±20%, 50V
C220	24797229	EL, 2.2µF, ±20%, 50V
C221	24232103	CD, 0.01µF, +80%, -20%
C222	24232103	CD, 0.01µF, +80%, -20%
C223	24232103	CD, 0.01µF, +80%, -20%
C224	24539104	PF, 0.1µF
C225	24539104	PF, 0.1µF
C226	24539104	PF, 0.1µF
C245	24206108	EL, 0.1µF, ±20%, 50V
C261	24539104	PF, 0.1µF
C262	24539104	PF, 0.1µF
C263	24539104	PF, 0.1µF
C305	24617912	EL, 2.2µF, ±10%, 50V
C306	24073058	EL, 2200µF, ±20%, 25V
C307	24693223	PF, 0.022µF, 100V
C308	24668221	EL, 220µF, ±20%, 35V
C309	24591102	PF, 1000pF
C310	24796102	EL, 1000µF, ±20%, 35V
C311	24435820	CD, 82pF, 500V
C313	24082057	PF, 0.22µF, 100V
C314	24539473	PF, 0.047µF
C317	24214471	CD, 470pF, ±10%, 500V
C319	24212102	CD, 1000pF, ±10%
C320	24668101	EL, 100µF, ±20%, 35V
C323	24567474	PF, 0.47µF
C325	24567683	PF, 0.068µF
C326	24539104	PF, 0.1µF
C327	24617915	EL, 1µF, ±10%, 50V
C337	24797229	EL, 2.2µF, ±20%, 50V
C360	24793221	EL, 220µF, ±20%, 10V
C403	24591103	PF, 0.01µF
C404	24797010	EL, 1µF, ±20%, 50V
C407	24591104	PF, 0.1µF

Location No.	Part No.	Description
C410	24232103	CD, 0.01µF, +80%, -20%
C413	24214821	CD, 820pF, ±10%, 500V
C415	24567273	PF, 0.027µF
C416	24678010	EL, 1µF, ±20%, 200V
C417	24214391	CD, 390pF, ±10%, 500V
C421	24794101	EL, 100µF, ±20%, 16V
C430	24232103	CD, 0.01µF, +80%, -20%
C431	24794101	EL, 100µF, ±20%, 16V
△C440	24082928	PF, 7000pF, ±3%, 1500V
△C442	24082922	PF, 0.47µF, 315V
△C444	24082956	PF, 7200pF, ±3%, 1500V
C445	24828563	PF, 0.056µF, 200V
C446	24679100	EL, 10µF, ±20%, 250V
C448	24640908	EL, 33µF, ±20%, 160V
C449	24666102	EL, 1000µF, ±20%, 16V
C457	24591222	PF, 2200pF
C463	24212152	CD, 1500pF, ±10%
C471	24797479	EL, 4.7µF, ±20%, 50V
C474	24794100	EL, 10µF, ±20%, 16V
C480	24747220	EL, 22µF, ±20%, 50V
C481	24567474	PF, 0.47µF
C482	24766478	EL, 0.47µF, ±20%, 50V
C499	24212102	CD, 1000pF, ±10%
C501	24436102	CD, 1000pF
C504	24591222	PF, 2200pF
C505	24353120	CD, 12pF, CH
C510	24763101	EL, 100µF, ±20%, 16V
C511	24232103	CD, 0.01µF, +80%, -20%
C512	24206228	EL, 0.22µF, ±20%, 50V
C582	24232103	CD, 0.01µF, +80%, -20%
C583	24762471	EL, 470µF, ±20%, 10V
C612	24794470	EL, 47µF, ±20%, 16V
C661	24212102	CD, 1000pF, ±10%
C662	24212102	CD, 1000pF, ±10%
C663	24794100	EL, 10µF, ±20%, 16V
C671	24667470	EL, 47µF, ±20%, 25V
C672	24667470	EL, 47µF, ±20%, 25V
C673	24669229	EL, 2.2µF, ±20%, 50V
C676	24539104	PF, 0.1µF
C677	24539104	PF, 0.1µF
C678	24669229	EL, 2.2µF, ±20%, 50V

Location No.	Part No.	Description
C679	24667470	EL, 47 $\mu$ F, $\pm$ 20%, 25V
C681	24667102	EL, 1000 $\mu$ F, $\pm$ 20%, 25V
C682	24668101	EL, 100 $\mu$ F, $\pm$ 20%, 35V
C683	24667102	EL, 1000 $\mu$ F, $\pm$ 20%, 25V
C801	24095670	PF, 0.22 $\mu$ F, $\pm$ 20%, AC125V
C802	24095852	PF, 0.082 $\mu$ F, $\pm$ 20%, AC125V
C805	24092623	CD, 0.01 $\mu$ F, +80%, -20%, AC250V
C806	24092623	CD, 0.01 $\mu$ F, +80%, -20%, AC250V
C808	24667101	EL, 100 $\mu$ F, $\pm$ 20%, 25V
C810	24086061	EL, 470 $\mu$ F, $\pm$ 20%, 200V
C811	24092597	CD, 4700pF, $\pm$ 20%, AC250V
C812	24092597	CD, 4700pF, $\pm$ 20%, AC250V
C813	24092597	CD, 4700pF, $\pm$ 20%, AC250V
C815	24092597	CD, 4700pF, $\pm$ 20%, AC250V
C816	24092597	CD, 4700pF, $\pm$ 20%, AC250V
C817	24092339	CD, 330pF, $\pm$ 10%, 2kV
C818	24082402	PF, 2200pF, $\pm$ 3%, 1250V
C821	24214471	CD, 470pF, $\pm$ 10%, 500V
C822	24567104	PF, 0.1 $\mu$ F
C823	24212471	CD, 470pF, $\pm$ 10%
C829	24591152	PF, 1500pF
C832	24794470	EL, 47 $\mu$ F, $\pm$ 20%, 16V
C840	24795221	EL, 220 $\mu$ F, $\pm$ 20%, 25V
C842	24792101	EL, 100 $\mu$ F, $\pm$ 20%, 6.3V
C843	24797479	EL, 4.7 $\mu$ F, $\pm$ 20%, 50V
C884	24086049	EL, 330 $\mu$ F, $\pm$ 20%, 160V
C885	24214471	CD, 470pF, $\pm$ 10%, 500V
C889	24796222	EL, 2200 $\mu$ F, $\pm$ 20%, 35V
C891	24567104	PF, 0.1 $\mu$ F
C893	24092339	CD, 330pF, $\pm$ 10%, 2kV
C898	24539224	PF, 0.22 $\mu$ F
C902	24092345	CD, 1000pF, $\pm$ 10%, 2kV
C904	24436471	CD, 470pF
C905	24436471	CD, 470pF
C907	24436471	CD, 470pF
C909	24679220	EL, 22 $\mu$ F, $\pm$ 20%, 250V
C910	24797478	EL, 0.47 $\mu$ F, $\pm$ 20%, 50V
C911	24794100	EL, 10 $\mu$ F, $\pm$ 20%, 16V
C912	24763471	EL, 470 $\mu$ F, $\pm$ 20%, 16V
C913	24794100	EL, 10 $\mu$ F, $\pm$ 20%, 16V
C914	24232103	CD, 0.01 $\mu$ F, +80%, -20%
C920	24214101	CD, 100pF, $\pm$ 10%, 500V
C921	24232103	CD, 0.01 $\mu$ F, +80%, -20%
C922	24232103	CD, 0.01 $\mu$ F, +80%, -20%
CA13	24474101	CD, 100pF, $\pm$ 10%
CA33	24232103	CD, 0.01 $\mu$ F, +80%, -20%
CA37	24474101	CD, 100pF, $\pm$ 10%
CA38	24474101	CD, 100pF, $\pm$ 10%
CA42	24794100	EL, 10 $\mu$ F, $\pm$ 20%, 16V
CA43	24232103	CD, 0.01 $\mu$ F, +80%, -20%
CA44	24232103	CD, 0.01 $\mu$ F, +80%, -20%
CA68	24794100	EL, 10 $\mu$ F, $\pm$ 20%, 16V
CA69	24232103	CD, 0.01 $\mu$ F, +80%, -20%
CB01	24797470	EL, 47 $\mu$ F, $\pm$ 20%, 50V
CB20	24212101	CD, 100pF, $\pm$ 10%
CB60	24085944	EL, 2.2 $\mu$ F, $\pm$ 20%, 50V, Non-Polar
CB61	24591102	PF, 1000pF
CB62	24436561	CD, 560pF
CB63	24591122	PF, 1200pF
CB64	24763471	EL, 470 $\mu$ F, $\pm$ 20%, 16V
CB65	24591104	PF, 0.1 $\mu$ F

Location No.	Part No.	Description
CG02	24203220	EL, 22 $\mu$ F, $\pm$ 20%, 16V
CG03	24539104	PF, 0.1 $\mu$ F
CG05	24797010	EL, 1 $\mu$ F, $\pm$ 20%, 50V
CG06	24797479	EL, 4.7 $\mu$ F, $\pm$ 20%, 50V
CG07	24206229	EL, 2.2 $\mu$ F, $\pm$ 20%, 50V
CG08	24591473	PF, 0.047 $\mu$ F
CG09	24797478	EL, 0.47 $\mu$ F, $\pm$ 20%, 50V
CG10	24539104	PF, 0.1 $\mu$ F
CG12	24206108	EL, 0.1 $\mu$ F, $\pm$ 20%, 50V
CG14	24797010	EL, 1 $\mu$ F, $\pm$ 20%, 50V
CG16	24704106	Tantalum, 10 $\mu$ F, $\pm$ 20%, 16V
CG17	24797010	EL, 1 $\mu$ F, $\pm$ 20%, 50V
CG18	24797010	EL, 1 $\mu$ F, $\pm$ 20%, 50V
CG19	24797479	EL, 4.7 $\mu$ F, $\pm$ 20%, 50V
CG20	24797010	EL, 1 $\mu$ F, $\pm$ 20%, 50V
CG25	24797479	EL, 4.7 $\mu$ F, $\pm$ 20%, 50V
CG26	24797479	EL, 4.7 $\mu$ F, $\pm$ 20%, 50V
CG27	24591223	PF, 0.022 $\mu$ F
CG28	24797229	EL, 2.2 $\mu$ F, $\pm$ 20%, 50V
CG29	24591102	PF, 1000pF
CG30	24206108	EL, 0.1 $\mu$ F, $\pm$ 20%, 50V
CG31	24797229	EL, 2.2 $\mu$ F, $\pm$ 20%, 50V
CG32	24591102	PF, 1000pF
CG33	24206108	EL, 0.1 $\mu$ F, $\pm$ 20%, 50V
CG36	24206229	EL, 2.2 $\mu$ F, $\pm$ 20%, 50V
CG37	24206229	EL, 2.2 $\mu$ F, $\pm$ 20%, 50V
CG38	24206229	EL, 2.2 $\mu$ F, $\pm$ 20%, 50V
CG39	24206229	EL, 2.2 $\mu$ F, $\pm$ 20%, 50V
CG42	24206010	EL, 1 $\mu$ F, $\pm$ 20%, 50V
CG44	24203100	EL, 10 $\mu$ F, $\pm$ 20%, 16V
CG46	24203101	EL, 100 $\mu$ F, $\pm$ 20%, 16V
CM01	24591103	PF, 0.01 $\mu$ F
CM02	24781561	Chip, 560pF, SL
CM03	24591104	PF, 0.1 $\mu$ F
CM04	24591104	PF, 0.1 $\mu$ F
CM05	24591102	PF, 1000pF
CM06	24591683	PF, 0.068 $\mu$ F
CM08	24794101	EL, 100 $\mu$ F, $\pm$ 20%, 16V
CM09	24591104	PF, 0.1 $\mu$ F
CM10	24085981	EL, 10 $\mu$ F, $\pm$ 20%, 16V, Non-Polar
CM11	24794101	EL, 100 $\mu$ F, $\pm$ 20%, 16V
CM12	24781561	Chip, 560pF, SL
CM15	24814103	Chip, 0.01 $\mu$ F, +80%, -20%
CM51	24539104	PF, 0.1 $\mu$ F
CM55	24436101	CD, 100pF
CM58	24539104	PF, 0.1 $\mu$ F
CR01	24232103	CD, 0.01 $\mu$ F, +80%, -20%
CR02	24232103	CD, 0.01 $\mu$ F, +80%, -20%
CR03	24232103	CD, 0.01 $\mu$ F, +80%, -20%
CS70	24794220	EL, 22 $\mu$ F, $\pm$ 20%, 16V
CS71	24794220	EL, 22 $\mu$ F, $\pm$ 20%, 16V
CV01	24206108	EL, 0.1 $\mu$ F, $\pm$ 20%, 50V
CV03	24206108	EL, 0.1 $\mu$ F, $\pm$ 20%, 50V
CV05	24232103	CD, 0.01 $\mu$ F, +80%, -20%
CV07	24206108	EL, 0.1 $\mu$ F, $\pm$ 20%, 50V
CV09	24206108	EL, 0.1 $\mu$ F, $\pm$ 20%, 50V
CV11	24232103	CD, 0.01 $\mu$ F, +80%, -20%
CV23	24203100	EL, 10 $\mu$ F, $\pm$ 20%, 16V
CV29	24232103	CD, 0.01 $\mu$ F, +80%, -20%
CV31	24206108	EL, 0.1 $\mu$ F, $\pm$ 20%, 50V
CV36	24794220	EL, 22 $\mu$ F, $\pm$ 20%, 16V
CV38	24763221	EL, 220 $\mu$ F, $\pm$ 20%, 16V
CV39	24232103	CD, 0.01 $\mu$ F, +80%, -20%

Location No.	Part No.	Description
CV41	24591223	PF, 0.022 $\mu$ F
CV60	24763471	EL, 470 $\mu$ F, $\pm$ 20%, 16V
CV61	24762471	EL, 470 $\mu$ F, $\pm$ 20%, 10V
CY01	24474151	CD, 150pF, $\pm$ 10%
CY10	24781680	Chip, 68pF, SL
CY11	24203330	EL, 33 $\mu$ F, $\pm$ 20%, 16V
CY12	24762221	EL, 220 $\mu$ F, $\pm$ 20%, 10V
CY13	24092293	Chip, 0.1 $\mu$ F, +80%, -20%, 25V
CY14	24814103	Chip, 0.01 $\mu$ F, +80%, -20%
CY19	24092293	Chip, 0.1 $\mu$ F, +80%, -20%, 25V
CY20	24591333	PF, 0.033 $\mu$ F
CY21	24590154	PF, 0.15 $\mu$ F
CY22	24590104	PF, 0.1 $\mu$ F
CY23	24203100	EL, 10 $\mu$ F, $\pm$ 20%, 16V
CY24	24774120	Chip, 12pF, CH
CY25	24814103	Chip, 0.01 $\mu$ F, +80%, -20%
CY26	24814103	Chip, 0.01 $\mu$ F, +80%, -20%
CY27	24092293	Chip, 0.1 $\mu$ F, +80%, -20%, 25V
CY29	24092293	Chip, 0.1 $\mu$ F, +80%, -20%, 25V
CY30	24774120	Chip, 12pF, CH
CY31	24814103	Chip, 0.01 $\mu$ F, +80%, -20%
CY32	24762221	EL, 220 $\mu$ F, $\pm$ 20%, 10V
CY33	24092293	Chip, 0.1 $\mu$ F, +80%, -20%, 25V
CY34	24814103	Chip, 0.01 $\mu$ F, +80%, -20%
CY35	24590104	PF, 0.1 $\mu$ F
CY36	24590104	PF, 0.1 $\mu$ F
CY37	24092293	Chip, 0.1 $\mu$ F, +80%, -20%, 25V
CY38	24762221	EL, 220 $\mu$ F, $\pm$ 20%, 10V
CY39	24203100	EL, 10 $\mu$ F, $\pm$ 20%, 16V
CY40	24092293	Chip, 0.1 $\mu$ F, +80%, -20%, 25V
CY41	24092293	Chip, 0.1 $\mu$ F, +80%, -20%, 25V
CY42	24781151	Chip, 150pF, SL
CY43	24814103	Chip, 0.01 $\mu$ F, +80%, -20%
CY44	24203100	EL, 10 $\mu$ F, $\pm$ 20%, 16V
CY49	24781680	Chip, 68pF, SL
CY50	24092293	Chip, 0.1 $\mu$ F, +80%, -20%, 25V
CY52	24814103	Chip, 0.01 $\mu$ F, +80%, -20%
CY53	24590154	PF, 0.15 $\mu$ F
CY54	24206339	EL, 3.3 $\mu$ F, $\pm$ 20%, 50V
CY62	24781101	Chip, 100pF, SL
CY63	24781101	Chip, 100pF, SL
CY64	24092293	Chip, 0.1 $\mu$ F, +80%, -20%, 25V
CY65	24781560	Chip, 56pF, SL
CY66	24781151	Chip, 150pF, SL
CY67	24085981	EL, 10 $\mu$ F, $\pm$ 20%, 16V, Non-Polar
CY68	24781101	Chip, 100pF, SL
CY69	24781100	Chip, 10pF, $\pm$ 0.5pF%, SL
CY70	24085958	EL, 1.0 $\mu$ F, $\pm$ 20%, 50V, Non-Polar
CY71	24781121	Chip, 120pF, SL
CY72	24781560	Chip, 56pF, SL
CY73	24762221	EL, 220 $\mu$ F, $\pm$ 20%, 10V
CY74	24092293	Chip, 0.1 $\mu$ F, +80%, -20%, 25V
CY76	24781101	Chip, 100pF, SL
CY77	24781330	Chip, 33pF, SL
CY78	24201330	EL, 33 $\mu$ F, 6.3V
CY79	24814103	Chip, 0.01 $\mu$ F, +80%, -20%
CY80	24092293	Chip, 0.1 $\mu$ F, +80%, -20%, 25V
CZ03	24092442	Chip, 0.47 $\mu$ F, +80%, -20%, 16V
CZ05	24814103	Chip, 0.01 $\mu$ F, +80%, -20%
CZ07	24092178	Chip, 0.1 $\mu$ F, $\pm$ 10%, 25V
CZ09	24781220	Chip, 22pF, SL

Location No.	Part No.	Description
CZ10	24781100	Chip, 10pF, $\pm$ 0.5pF%, SL
CZ11	24781220	Chip, 22pF, SL
CZ12	24814103	Chip, 0.01 $\mu$ F, +80%, -20%
CZ13	24814103	Chip, 0.01 $\mu$ F, +80%, -20%
CZ14	24203100	EL, 10 $\mu$ F, $\pm$ 20%, 16V
CZ17	24814103	Chip, 0.01 $\mu$ F, +80%, -20%
CZ19	24781181	Chip, 180pF, SL
CZ20	24814103	Chip, 0.01 $\mu$ F, +80%, -20%
CZ21	24781122	Chip, 1200pF, SL
CZ22	24203100	EL, 10 $\mu$ F, $\pm$ 20%, 16V
CZ23	24814103	Chip, 0.01 $\mu$ F, +80%, -20%
CZ24	24814103	Chip, 0.01 $\mu$ F, +80%, -20%
CZ25	24203100	EL, 10 $\mu$ F, $\pm$ 20%, 16V
CZ26	24814103	Chip, 0.01 $\mu$ F, +80%, -20%
CZ28	24814103	Chip, 0.01 $\mu$ F, +80%, -20%
CZ29	24814103	Chip, 0.01 $\mu$ F, +80%, -20%
CZ30	24203100	EL, 10 $\mu$ F, $\pm$ 20%, 16V
CZ31	24092178	Chip, 0.1 $\mu$ F, $\pm$ 10%, 25V
CZ32	24781150	Chip, 15pF, SL
CZ33	24781390	Chip, 39pF, SL
CZ34	24781150	Chip, 15pF, SL
CZ35	24781390	Chip, 39pF, SL
CZ37	24203100	EL, 10 $\mu$ F, $\pm$ 20%, 16V
CZ38	24203100	EL, 10 $\mu$ F, $\pm$ 20%, 16V
CZ41	24781470	Chip, 47pF, SL
CZ42	24781470	Chip, 47pF, SL
CZ45	24781100	Chip, 10pF, $\pm$ 0.5pF%, SL
CZ46	24436120	CD, 12pF

### RESISTORS

R101	24382223	OMF, 22k ohm, 1W
R201	24366101	CF, 100 ohm
R203	24366474	CF, 470k ohm
R207	24366101	CF, 100 ohm
R208	24366101	CF, 100 ohm
R209	24366101	CF, 100 ohm
R216	24366223	CF, 22k ohm
R223	24366471	CF, 470 ohm
R228	24366683	CF, 68k ohm
R238	24366473	CF, 47k ohm
R239	24366274	CF, 270k ohm
R240	24366562	CF, 5600 ohm
R241	24366682	CF, 6800 ohm
R245	24366104	CF, 100k ohm
R261	24366472	CF, 4700 ohm
R262	24366102	CF, 1k ohm
R263	24366472	CF, 4700 ohm
R264	24366102	CF, 1k ohm
R265	24366472	CF, 4700 ohm
R266	24366102	CF, 1k ohm
R271	24366101	CF, 100 ohm
R272	24366222	CF, 2200 ohm
R301	24366102	CF, 1k ohm
R303	24321109	MF, 1 ohm, 1/2W
R304	24366473	CF, 47k ohm
R305	24322758	MF, 0.75 ohm, 1W
R306	24366273	CF, 27k ohm
R307	24366824	CF, 820k ohm
R308	24383391	OMF, 390 ohm, 2W
R309	24553221	OMF, 220 ohm, 1W
R310	24366153	CF, 15k ohm
R311	24366392	CF, 3900 ohm
R313	24366243	CF, 24k ohm
R314	24366105	CF, 1M ohm

Location No.	Part No.	Description
R315	24366824	CF, 820k ohm
R317	24366102	CF, 1k ohm
R327	24339479	MF, 4.7 ohm, 2W
R328	24366564	CF, 560k ohm
R336	24383391	OMF, 390 ohm, 2W
R360	24366104	CF, 100k ohm
R361	24366473	CF, 47k ohm
R368	24545479	FR, 4.7 ohm, 1/4W
R369	24366391	CF, 390 ohm
R401	24366391	CF, 390 ohm
R403	24366622	CF, 6200 ohm
R405	24382682	OMF, 6800 ohm, 1W
R406	24366104	CF, 100k ohm
R407	24366103	CF, 10k ohm
R408	24366472	CF, 4700 ohm
R410	24366271	CF, 270 ohm
R411	24366151	CF, 150 ohm
R415	24553272	OMF, 2700 ohm, 1W
R416	24510332	Cement, 3k ohm, 5W
R418	24383181	OMF, 180 ohm, 2W
R424	24546279	FR, 2.7 ohm, 1/2W
R425	24366561	CF, 560 ohm
R430	24366102	CF, 1k ohm
R431	24366103	CF, 10k ohm
R432	24366202	CF, 2k ohm
R442	24532102	FR, 1k ohm, 1W
R448	24338478	MF, 0.47 ohm, 1W
R456	24366103	CF, 10k ohm
R457	24366104	CF, 100k ohm
R472	24381270	OMF, 27 ohm, 1/2W
△ R475	24366181	CF, 180 ohm
R476	24366823	CF, 82k ohm
R477	24366273	CF, 27k ohm
△ R478	24327133	MF, 13k ohm, ±1%, 1/4W
R481	24366333	CF, 33k ohm
△ R482	24327562	MF, 5600 ohm, ±1%, 1/4W
R485	24338568	MF, 0.56 ohm, 1W
R486	24552820	OMF, 82 ohm, 1/2W
R487	24552301	OMF, 300 ohm, 1/2W
R488	24327183	MF, 18k ohm, ±1%, 1/4W
R489	24327183	MF, 18k ohm, ±1%, 1/4W
R490	24366102	CF, 1k ohm
R493	24366102	CF, 1k ohm
R494	24366471	CF, 470 ohm
R495	24366561	CF, 560 ohm
R498	24510279	Cement, 2.7 ohm, 5W
R501	24366333	CF, 33k ohm
R502	24366101	CF, 100 ohm
R503	24366101	CF, 100 ohm
R511	24366471	CF, 470 ohm
R612	24366103	CF, 10k ohm
R613	24366222	CF, 2200 ohm
R614	24366102	CF, 1k ohm
R661	24366682	CF, 6800 ohm
R662	24366682	CF, 6800 ohm
R663	24366332	CF, 3300 ohm
R664	24366332	CF, 3300 ohm
R667	24366223	CF, 22k ohm
R668	24366103	CF, 10k ohm
R669	24366103	CF, 10k ohm
R676	24366229	CF, 2.2 ohm
R677	24366229	CF, 2.2 ohm
R808	24019483	PTC Thermistor, 7.0 ohm

Location No.	Part No.	Description
R810	24569828	Cement, 0.82 ohm, ±10%, 10W
R814	24366103	CF, 10k ohm
R815	24552332	OMF, 3300 ohm, 1/2W
R818	24323479	MF, 4.7 ohm, 2W
R820	24322228	MF, 0.22 ohm, 1W
R821	24552470	OMF, 47 ohm, 1/2W
R823	24366222	CF, 2200 ohm
R829	24322228	MF, 0.22 ohm, 1W
R830	24322759	MF, 7.5 ohm, 1W
R831	24366561	CF, 560 ohm
R835	24552681	OMF, 680 ohm, 1/2W
R861	24553223	OMF, 22k ohm, 1W
R883	24366471	CF, 470 ohm
R884	24366471	CF, 470 ohm
R888	24321228	MF, 0.22 ohm, 1/2W
R891	24366102	CF, 1k ohm
R898	24002000	CC, 3.9M ohm, ±10%, 1/2W
R901	24552102	OMF, 1k ohm, 1/2W
R902	24552102	OMF, 1k ohm, 1/2W
R903	24552102	OMF, 1k ohm, 1/2W
R904	24366103	CF, 10k ohm
R905	24366101	CF, 100 ohm
R911	24366150	CF, 15 ohm
R914	24366561	CF, 560 ohm
R915	24366221	CF, 220 ohm
R917	24366102	CF, 1k ohm
R918	24366820	CF, 82 ohm
R920	24000945	FR, 1.8 ohm, 2W
R921	24366561	CF, 560 ohm
R922	24366221	CF, 220 ohm
R924	24366820	CF, 82 ohm
R925	24366102	CF, 1k ohm
R928	24366561	CF, 560 ohm
R929	24366221	CF, 220 ohm
R930	24366820	CF, 82 ohm
R932	24366272	CF, 2700 ohm
R934	24366391	CF, 390 ohm
R935	24366821	CF, 820 ohm
R936	24366750	CF, 75 ohm
R937	24366102	CF, 1k ohm
R939	24366101	CF, 100 ohm
R942	24366562	CF, 5600 ohm
R943	24366562	CF, 5600 ohm
R944	24366562	CF, 5600 ohm
R960	24383153	OMF, 15k ohm, 2W
R961	24383153	OMF, 15k ohm, 2W
R962	24383153	OMF, 15k ohm, 2W
R977	24366122	CF, 1200 ohm
R980	24366471	CF, 470 ohm
R981	24366821	CF, 820 ohm
R982	24366103	CF, 10k ohm
R983	24366222	CF, 2200 ohm
R984	24367152	CF, 1500 ohm, ±2%
R985	24367471	CF, 470 ohm, ±2%
R986	24367681	CF, 680 ohm, ±2%
R987	24367681	CF, 680 ohm, ±2%
R988	24367472	CF, 4700 ohm, ±2%
R989	24367472	CF, 4700 ohm, ±2%
R990	24366222	CF, 2200 ohm
R991	24367681	CF, 680 ohm, ±2%
RA03	24366102	CF, 1k ohm
RA04	24366102	CF, 1k ohm
RA07	24366102	CF, 1k ohm

Location No.	Part No.	Description
RA08	24366102	CF, 1k ohm
RA09	24366102	CF, 1k ohm
RA10	24366102	CF, 1k ohm
RA13	24366103	CF, 10k ohm
RA15	24366102	CF, 1k ohm
RA16	24366102	CF, 1k ohm
RA17	24366102	CF, 1k ohm
RA18	24366102	CF, 1k ohm
RA21	24366102	CF, 1k ohm
RA22	24366331	CF, 330 ohm
RA23	24366331	CF, 330 ohm
RA24	24366331	CF, 330 ohm
RA25	24366331	CF, 330 ohm
RA26	24366102	CF, 1k ohm
RA27	24366102	CF, 1k ohm
RA33	24366103	CF, 10k ohm
RA34	24366102	CF, 1k ohm
RA35	24366102	CF, 1k ohm
RA36	24366102	CF, 1k ohm
RA37	24366331	CF, 330 ohm
RA38	24366331	CF, 330 ohm
RA40	24366101	CF, 100 ohm
RA41	24366101	CF, 100 ohm
RA61	24366103	CF, 10k ohm
RA62	24366103	CF, 10k ohm
RA67	24366472	CF, 4700 ohm
RA68	24366472	CF, 4700 ohm
RA70	24366332	CF, 33k ohm
RA71	24366683	CF, 68k ohm
RA72	24366223	CF, 22k ohm
RA73	24366103	CF, 10k ohm
RB01	24366271	CF, 270 ohm
RB03	24366101	CF, 100 ohm
RB09	24366470	CF, 47 ohm
RB11	24366103	CF, 10k ohm
RB24	24366472	CF, 4700 ohm
RB25	24366472	CF, 4700 ohm
RB27	24366103	CF, 10k ohm
RB28	24366104	CF, 100k ohm
RB29	24366102	CF, 1k ohm
RB30	24366103	CF, 10k ohm
RB40	24366103	CF, 10k ohm
RB41	24366152	CF, 1500 ohm
RB42	24366102	CF, 1k ohm
RB43	24366103	CF, 10k ohm
RB44	24366103	CF, 10k ohm
RB45	24366181	CF, 180 ohm
RB46	24366101	CF, 100 ohm
RB60	24366101	CF, 100 ohm
RB61	24366244	CF, 240k ohm
RB62	24366133	CF, 13k ohm
RB63	24366392	CF, 3900 ohm
RB64	24366103	CF, 10k ohm
RB65	24366103	CF, 10k ohm
RB66	24366221	CF, 220 ohm
RB67	24366102	CF, 1k ohm
RG05	24366102	CF, 1k ohm
RG08	24366684	CF, 680k ohm
RG09	24366393	CF, 39k ohm
RG14	24366332	CF, 3300 ohm
RG15	24327153	MF, 15k ohm, $\pm 1\%$ , 1/4W
RG16	24366162	CF, 1600 ohm
RG17	24366472	CF, 4700 ohm
RG22	24366101	CF, 100 ohm

Location No.	Part No.	Description
RG23	24366101	CF, 100 ohm
RG36	24366472	CF, 4700 ohm
RG37	24366472	CF, 4700 ohm
RG41	24366103	CF, 10k ohm
RG43	24366472	CF, 4700 ohm
RG44	24366222	CF, 2200 ohm
RG45	24545479	FR, 4.7 ohm, 1/4W
RG46	24552681	OMF, 680 ohm, 1/2W
RM02	24366332	CF, 3300 ohm
RM03	24872102	Chip, 1k ohm, 1/16W
RM04	24872102	Chip, 1k ohm, 1/16W
RM05	24872471	Chip, 470 ohm, 1/16W
RM06	24872822	Chip, 8200 ohm, 1/16W
RM07	24000633	MF, 10k ohm, 1/4W
RM08	24872102	Chip, 1k ohm, 1/16W
RM09	24872101	Chip, 100 ohm, 1/16W
RM10	24872101	Chip, 100 ohm, 1/16W
RM14	24872153	Chip, 15k ohm, 1/16W
RM15	24872153	Chip, 15k ohm, 1/16W
RM16	24872102	Chip, 1k ohm, 1/16W
RM17	24872122	Chip, 1200 ohm, 1/16W
RM18	24872102	Chip, 1k ohm, 1/16W
RM19	24872472	Chip, 4700 ohm, 1/16W
RM20	24872103	Chip, 10k ohm, 1/16W
RM21	24872332	Chip, 3300 ohm, 1/16W
RM25	24872223	Chip, 22k ohm, 1/16W
RM50	24366103	CF, 10k ohm
RM56	24366332	CF, 3300 ohm
RR93	24366472	CF, 4700 ohm
RS21	24366472	CF, 4700 ohm
RS24	24366472	CF, 4700 ohm
RS60	24366101	CF, 100 ohm
RS61	24366222	CF, 2200 ohm
RS62	24366101	CF, 100 ohm
RS63	24366222	CF, 2200 ohm
RS64	24366102	CF, 1k ohm
RS65	24366102	CF, 1k ohm
RS66	24366102	CF, 1k ohm
RS68	24366223	CF, 22k ohm
RS69	24366223	CF, 22k ohm
RS70	24366104	CF, 100k ohm
RS71	24366104	CF, 100k ohm
RV01	24366750	CF, 75 ohm
RV02	24366750	CF, 75 ohm
RV03	24366750	CF, 75 ohm
RV04	24366750	CF, 75 ohm
RV07	24366103	CF, 10k ohm
RV08	24366102	CF, 1k ohm
RV09	24366223	CF, 22k ohm
RV10	24366153	CF, 15k ohm
RV11	24366103	CF, 10k ohm
RV12	24366102	CF, 1k ohm
RV19	24366101	CF, 100 ohm
RV20	24366101	CF, 100 ohm
RV60	24552101	OMF, 100 ohm, 1/2W
RV61	24366101	CF, 100 ohm
RV62	24366750	CF, 75 ohm
RV63	24366221	CF, 220 ohm
RW02	24366750	CF, 75 ohm
RW03	24366750	CF, 75 ohm
RY10	24366181	CF, 180 ohm
RY11	24366472	CF, 4700 ohm
RY12	24872333	Chip, 33k ohm, 1/16W
RY13	24872152	Chip, 1500 ohm, 1/16W

Location No.	Part No.	Description
RY14	24366102	CF, 1k ohm
RY15	24366273	CF, 27k ohm
RY16	24872102	Chip, 1k ohm, 1/16W
RY17	24872102	Chip, 1k ohm, 1/16W
RY18	24872102	Chip, 1k ohm, 1/16W
RY21	24872301	Chip, 300 ohm, 1/16W
RY22	24872104	Chip, 100k ohm, 1/16W
RY23	24872474	Chip, 470k ohm, 1/16W
RY24	24872153	Chip, 15k ohm, 1/16W
RY26	24872152	Chip, 1500 ohm, 1/16W
RY27	24872223	Chip, 22k ohm, 1/16W
RY28	24872333	Chip, 33k ohm, 1/16W
RY29	24872333	Chip, 33k ohm, 1/16W
RY30	24872104	Chip, 100k ohm, 1/16W
RY31	24872223	Chip, 22k ohm, 1/16W
RY34	24872102	Chip, 1k ohm, 1/16W
RY36	24872471	Chip, 470 ohm, 1/16W
RY38	24872361	Chip, 360 ohm, 1/16W
RY41	24872471	Chip, 470 ohm, 1/16W
RY45	24872101	Chip, 100 ohm, 1/16W
RY48	24872223	Chip, 22k ohm, 1/16W
RY61	24872102	Chip, 1k ohm, 1/16W
RY62	24872152	Chip, 1500 ohm, 1/16W
RY63	24872102	Chip, 1k ohm, 1/16W
RY65	24872152	Chip, 1500 ohm, 1/16W
RY68	24872102	Chip, 1k ohm, 1/16W
RY69	24872122	Chip, 1200 ohm, 1/16W
RY70	24872272	Chip, 2700 ohm, 1/16W
RY71	24872102	Chip, 1k ohm, 1/16W
RY72	24872102	Chip, 1k ohm, 1/16W
RY75	24872472	Chip, 4700 ohm, 1/16W
RY77	24872102	Chip, 1k ohm, 1/16W
RY78	24872102	Chip, 1k ohm, 1/16W
RY80	24872473	Chip, 47k ohm, 1/16W
RY81	24872124	Chip, 120k ohm, 1/16W
RY82	24872333	Chip, 33k ohm, 1/16W
RY85	24872471	Chip, 470 ohm, 1/16W
RY86	24872101	Chip, 100 ohm, 1/16W
RY87	24872101	Chip, 100 ohm, 1/16W
RY88	24872101	Chip, 100 ohm, 1/16W
RY89	24872102	Chip, 1k ohm, 1/16W
RY90	24872102	Chip, 1k ohm, 1/16W
RY91	24872100	Chip, 10 ohm, 1/16W
RY92	24872102	Chip, 1k ohm, 1/16W
RY93	24872102	Chip, 1k ohm, 1/16W
RY94	24872101	Chip, 100 ohm, 1/16W
RY95	24872101	Chip, 100 ohm, 1/16W
RY96	24872105	Chip, 1M ohm, 1/16W
RY97	24872102	Chip, 1k ohm, 1/16W
RY98	24872223	Chip, 22k ohm, 1/16W
RY99	24872683	Chip, 68k ohm, 1/16W
RZ01	24872102	Chip, 1k ohm, 1/16W
RZ02	24872102	Chip, 1k ohm, 1/16W
RZ03	24872332	Chip, 3300 ohm, 1/16W
RZ04	24872122	Chip, 1200 ohm, 1/16W
RZ05	24872471	Chip, 470 ohm, 1/16W
RZ06	24872821	Chip, 820 ohm, 1/16W
RZ08	24872122	Chip, 1200 ohm, 1/16W
RZ09	24872101	Chip, 100 ohm, 1/16W
RZ10	24872471	Chip, 470 ohm, 1/16W
RZ12	24872332	Chip, 3300 ohm, 1/16W
RZ13	24872122	Chip, 1200 ohm, 1/16W
RZ14	24872821	Chip, 820 ohm, 1/16W
RZ15	24872821	Chip, 820 ohm, 1/16W

Location No.	Part No.	Description
RZ17	24872471	Chip, 470 ohm, 1/16W
RZ18	24872122	Chip, 1200 ohm, 1/16W
RZ19	24872332	Chip, 3300 ohm, 1/16W
RZ20	24872101	Chip, 100 ohm, 1/16W
RZ22	24872471	Chip, 470 ohm, 1/16W
RZ29	24872331	Chip, 330 ohm, 1/16W
RZ30	24366102	CF, 1k ohm
RZ30	24872331	Chip, 330 ohm, 1/16W

### COILS & TRANSFORMERS

L101	23289220	Coil, Peaking, TRF4220AF
L301	23103880	Coil (Ferrite Bead), TEM2011Y
L400	23238714	Coil, Peaking, TRF4100AJ
△L441	23233072	Coil, Linearity, TLN2115G
L501	23289844	Coil, Peaking, TRF4470AT
L805	23248227	Coil, Choke, TLN3481AD
L806	23248227	Coil, Choke, TLN3481AD
L815	23103880	Coil (Ferrite Bead), TEM2011Y
L883	23103880	Coil (Ferrite Bead), TEM2011Y
L885	23248073	Coil, Choke, TLN3299D
L886	23103880	Coil (Ferrite Bead), TEM2011Y
L901	23200789	Coil, Degaussing, TSB-2205A
L902	23289221	Coil, Peaking, TRF4221AF
L903	23289221	Coil, Peaking, TRF4221AF
L904	23289221	Coil, Peaking, TRF4221AF
L910	23237991	Coil, Peaking, TRF4479AC
LA01	23289100	Coil, Peaking, TRF4100AF
LB01	23262280	Coil, IF, TRF1196D
LV01	23289840	Coil, Peaking, TRF4100AT
LV98	23103852	Coil, Filter, TEM2028AH
LV99	23103852	Coil, Filter, TEM2028AH
LY10	23238705	Coil, Peaking, TRF4560AJ
LY11	23289229	Coil, Peaking, TRF42R2AF
LY13	23289229	Coil, Peaking, TRF42R2AF
LY14	23238506	Coil, Peaking, TRF4229AJ
LY15	23238504	Coil, Peaking, TRF4159AJ
LY16	23103829	Chip (Ferrite Bead), TEM2122M
LY17	23289229	Coil, Peaking, TRF42R2AF
LY20	23289229	Coil, Peaking, TRF42R2AF
LY21	23238509	Coil, Peaking, TRF4151AJ
LY22	23238709	Coil, Peaking, TRF4270AJ
LY23	23289229	Coil, Peaking, TRF42R2AF
LZ01	23238710	Coil, Peaking, TRF4220AJ
LZ02	23238714	Coil, Peaking, TRF4100AJ
LZ03	23238714	Coil, Peaking, TRF4100AJ
LZ04	23238714	Coil, Peaking, TRF4100AJ
LZ05	23238714	Coil, Peaking, TRF4100AJ
LZ08	23238707	Coil, Peaking, TRF4390AJ
LZ11	23238710	Coil, Peaking, TRF4220AJ
LZ11	23289836	Coil, Peaking, TRF42R2AT
LZ12	23238710	Coil, Peaking, TRF4220AJ
T401	23224367	Transformer, Horiz. Drive, TLN1098AH
△T461	23236579	Transformer, Flyback, TFB4151AD
T801	23211726	Line Filter, TRF3229AQ
T840	23213513	Transformer, Power, TPW1459AZ
T862	23217460	Transformer, Converter, TPW3445AE
<b>SEMICONDUCTORS</b>		
Q202	23114528	Transistor, 2SC1740S, Q

Location No.	Part No.	Description
Q203	23114528	Transistor, 2SC1740S, Q
Q204	A6002040	Transistor, RN1204
Q205	A6002040	Transistor, RN1204
Q301	B0378560	IC, TA8427K
Q301B	72471082	Screw, BRDT2W3X10 SZN
Q361	23314444	Transistor, 2SC4721P
Q402	A6330069	Transistor, 2CS2482 FA-1
Q403	23314444	Transistor, 2SC4721P
Q404	A6873702	Transistor, 2SD2539
Q404B	72471082	Screw, BRDT2W3X10 SZN
Q421	23314141	Transistor, 2SC3852
Q421B	23035308	Screw, BTB3X8SZN
Q471	A6534020	Transistor, 2SA1015-O
Q472	23114528	Transistor, 2SC1740S, Q
Q480	A6532853	Transistor, 2SA949-Y(C)
Q481	23114528	Transistor, 2SC1740S, Q
Q482	23114528	Transistor, 2SC1740S, Q
Q483	A6012010	Transistor, RN2201
Q610	B01A0068	IC, TA8265K
Q610B	70391356	Screw, BITTB3X10 SZN
Q611	A6342200	Transistor, 2CS2878-A
Q612	23314962	Transistor, KTA1266 Y
Q613	A6342200	Transistor, 2CS2878-A
Q801	23135012	IC, STR-G6624
Q801B	72471082	Screw, BRDT2W3X10 SZN
Q830	23314141	Transistor, 2SC3852
Q830B	23035308	Screw, BTB3X8SZN
Q840	23318299	IC, L78MR05
Q843	A6002050	Transistor, RN1205
Q862	A8643135	Photo Coupler, TLP621(GRL)
△ Q883	A6907894	IC, S1854A(FA4)
Q901	A6368700	Transistor, 2CS4544
Q902	23114528	Transistor, 2SC1740S, Q
Q903	A6368700	Transistor, 2CS4544
Q904	23114528	Transistor, 2SC1740S, Q
Q905	A6368700	Transistor, 2CS4544
Q906	23114528	Transistor, 2SC1740S, Q
Q907	23114530	Transistor, 2SA933S-Q
Q908	A6321240	Transistor, 2SC2120-Y
Q910	23114528	Transistor, 2SC1740S, Q
Q911	23114528	Transistor, 2SC1740S, Q
Q912	23114530	Transistor, 2SA933S-Q
Q913	23114530	Transistor, 2SA933S-Q
Q914	23114528	Transistor, 2SC1740S, Q
QA01	23000287	IC, TMPA8700CPN-1A05
QA02	70129486	IC, AT24C08-10PC
QB01	23114528	Transistor, 2SC1740S, Q
QB03	A6002050	Transistor, RN1205
QB21	23114528	Transistor, 2SC1740S, Q
QB23	23114528	Transistor, 2SC1740S, Q
QB30	23114528	Transistor, 2SC1740S, Q
QB40	23114528	Transistor, 2SC1740S, Q
QB60	23114530	Transistor, 2SA933S-Q
QB61	23114528	Transistor, 2SC1740S, Q
QB62	23114528	Transistor, 2SC1740S, Q
QG01	23906499	IC, $\mu$ PC1851BCU
QG05	A6333346	Transistor, 2SC2655-Y(C)
QM02	A6541130	Transistor, 2SA1162-Y
QM03	A6335470	Transistor, 2SC2712-Y
QM04	A6361770	Transistor, 2SC3437-Y
QM05	70119743	IC, PST523D
QM53	23314360	Transistor, DTC143TN
QS60	23314965	Transistor, KTC3198 Y
QS61	23314965	Transistor, KTC3198 Y

Location No.	Part No.	Description
QS62	A6012040	Transistor, RN2204
QS63	A6342200	Transistor, 2CS2878-A
QS64	A6342200	Transistor, 2CS2878-A
QV01	23906364	IC, MM1313BD
QV60	23114528	Transistor, 2SC1740S, Q
QY02	23906842	IC, M65617SP-B
QY05	A6333346	Transistor, 2SC2655-Y(C)
QY10	A6002040	Transistor, RN1204
QY11	A6541130	Transistor, 2SA1162-Y
QY12	A6361770	Transistor, 2SC3437-Y
QY13	A6734590	Transistor, 2SC752(G)TM-Y
QY14	A6335470	Transistor, 2SC2712-Y
QY15	A6335470	Transistor, 2SC2712-Y
QY16	A6335470	Transistor, 2SC2712-Y
QY17	A6541130	Transistor, 2SA1162-Y
QY18	A6335470	Transistor, 2SC2712-Y
QY20	A6335470	Transistor, 2SC2712-Y
QY21	A6335470	Transistor, 2SC2712-Y
QY23	A6541130	Transistor, 2SA1162-Y
QZ01	B0410895	IC, TC90A49P
QZ02	A6541130	Transistor, 2SA1162-Y
QZ03	A6541130	Transistor, 2SA1162-Y
QZ04	A6541130	Transistor, 2SA1162-Y
QZ05	A6335470	Transistor, 2SC2712-Y
QZ06	A6541130	Transistor, 2SA1162-Y
QZ07	A6541130	Transistor, 2SA1162-Y
QZ08	A6335470	Transistor, 2SC2712-Y
QZ11	23114528	Transistor, 2SC1740S, Q
D101	23316411	Diode, Zener, HZT33-12
D201	23118859	Diode, 1SS133
D221	23118859	Diode, 1SS133
D222	23118859	Diode, 1SS133
D225	23316686	Diode, Zener, MTZJ9.1A
D226	23316686	Diode, Zener, MTZJ9.1A
D301	23118095	Diode, ERB44-06, E
D302	23118094	Diode, EU2A, LF-F10
D308	23118822	Diode, ERB12-02
D309	23118822	Diode, ERB12-02
D310	23118859	Diode, 1SS133
D313	23118859	Diode, 1SS133
D316	23316673	Diode, Zener, MTZJ5.6C
D406	23118094	Diode, EU2A, LF-F10
D408	A7580658	Diode, 3JH41
D409	23316690	Diode, Zener, MTZJ10B
D411	23316684	Diode, Zener, MTZJ8.2B
D421	23316665	Diode, Zener, MTZJ4.7A
D422	23316669	Diode, Zener, MTZJ5.1B
D430	23316720	Diode, Zener, MTZJ12C
D441	23316687	Diode, Zener, MTZJ9.1B
D471	23118095	Diode, ERB44-06, E
△ D472	23115774	Diode, Zener, RD6.2E(4)
D473	23118859	Diode, 1SS133
D480	23316757	Diode, Zener, MTZJ36A
D611	23118859	Diode, 1SS133
D612	23118859	Diode, 1SS133
D801	23316391	Diode, D3SB60, 4109
D805	23118859	Diode, 1SS133
D806	23118094	Diode, EU2A
D807	23118859	Diode, 1SS133
D810	23316269	Diode, AK04
D815	23316746	Diode, Zener, MTZJ27B
D830	23316673	Diode, Zener, MTZJ5.6C
D840	23316962	Diode, S1WBA20 4101
D845	23118859	Diode, 1SS133

Location No.	Part No.	Description
D881	23118859	Diode, 1SS133
D883	23118338	Diode, RU-4AM LF-L1
△D884	23316721	Diode, Zener, MTZJ13A
D885	23118052	Diode, RU4Z LF-L1
D899	24019471	Varistor, TNR10V271K2
D901	23118859	Diode, 1SS133
D902	23118859	Diode, 1SS133
D903	23118859	Diode, 1SS133
D904	23118859	Diode, 1SS133
D905	23118859	Diode, 1SS133
D906	23118859	Diode, 1SS133
D911	23118095	Diode, ERB44-06, E
DA42	23316672	Diode, Zener, MTZJ5.6B
DB03	23358522	Diode (LED), SIR-56SB3F
DB30	23118859	Diode, 1SS133
DB45	23118859	Diode, 1SS133
DE50	23358501	Diode (LED), SCL003URC5F
DG02	23316690	Diode, Zener, MTZJ10B
DV01	23316686	Diode, Zener, MTZJ9.1A
DV03	23316686	Diode, Zener, MTZJ9.1A
DV05	23316686	Diode, Zener, MTZJ9.1A
DV07	23316686	Diode, Zener, MTZJ9.1A
DV09	23316686	Diode, Zener, MTZJ9.1A
DY10	23316660	Diode, Zener, MTZJ3.9A
DY11	23316820	Diode, 1SS353, TE17
DY12	23316820	Diode, 1SS353, TE17
DY14	23316820	Diode, 1SS353, TE17
DY15	23316820	Diode, 1SS353, TE17
<b>MISCELLANEOUS</b>		
B110	23162278	Holder, Antenna Terminal
B230	23035312	Screw, BTB 3X12 SZN
F301	23144908	Fuse, 0.5A, 125V
F301A	23165433	Holder, Fuse
F470	23144785	Fuse, 1.25A, 125V
F470A	23165433	Holder, Fuse
F801	23144888	Fuse, 5.0A, 125V
F801A	23165433	Holder, Fuse
F802	23144511	Fuse, 4.0A, 125V
G217	24366223	CF, 2200 ohm
G500	23289840	Coil, Peaking, TRF4100AT
G501	24366101	CF, 100 ohm
G816	23103880	Coil (Ferrite Bead), TEM2011Y
G890	23280016	Coil, Peaking, TRF4100AZ
G891	23280016	Coil, Peaking, TRF4100AZ
G908	23289100	Coil, Peaking, TRF4100AF
G916	24366101	CF, 100 ohm
G945	24366101	CF, 100 ohm
G946	24366101	CF, 100 ohm
GR01	24366470	CF, 47 ohm
GR02	24366101	CF, 100 ohm
GR03	24366101	CF, 100 ohm
JY100	24000824	Chip Jumper, 2125Type
JY101	24000824	Chip Jumper, 2125Type
KB01	23906805	Remote Sensor, PIC-TB17
P801	23372115	Power Cord
P910	23164725	Plug, 2P
PV01	23365818	Jack, SVHS
PV02	23365990	Jack, 6P
PV03	23365991	Jack, 5P
PZ01	23368130	Plug, B-B,10P
PZ01A	23902745	Socket, B-B, 10P
SA02	23145227	Switch, Push, 1C1P

Location No.	Part No.	Description
SA03	23145227	Switch, Push, 1C1P
SA04	23145227	Switch, Push, 1C1P
SA05	23145227	Switch, Push, 1C1P
SA06	23145227	Switch, Push, 1C1P
SA07	23145227	Switch, Push, 1C1P
SR81	23146564	Relay, DC12V
V901A	23902068	Socket, CRT, 10P
W661	23351088	Speaker, SPK-1360, 60X120mm, 8 ohm
W662	23351088	Speaker, SPK-1360, 60X120mm, 8 ohm
X401	23153721	Ceramic Resonator, 503kHz, TCR1023
X501	23153961	Crystal, 3.58MHz
XA01	23153504	Ceramic Resonator, 8.00MHz, TCR1056BM
XY01	23153899	Crystal, 14.31818MHz
<b>PC BOARD ASSEMBLIES</b>		
* U901		CRT Drive Board, PB8625B
* U902		Main Board, PB9549A
* UY01		PIP Board, PB8622
* UZ01		DIG COM Board, PB9398
<b>PICTURE TUBE</b>		
△V901	23312694	Picture Tube, A68ADT28X04
<b>TUNER</b>		
H001	23321366	Tuner, EL951L
<b>ACCESSORIES</b>		
K912	23306359	Remote Hand Unit, CT-90037
AT03	23588307	Battery Cover
Y101	23563890	Owner's Manual, English, 27A50
Y101F	23563891	Owner's Manual, French, 27A50
<b>CABINET PARTS</b>		
A224	23445342	Button, Control
A401	23005018	Back Cover
A701	23524502	Container
A703	23935996	Packing, Top
A708	23935997	Packing, Bottom

**THIS PAGE IS  
INTENTIONALLY LEFT  
BLANK.**

MAIN BOARD PB9549A  
BOTTOM (FOIL) SIDE

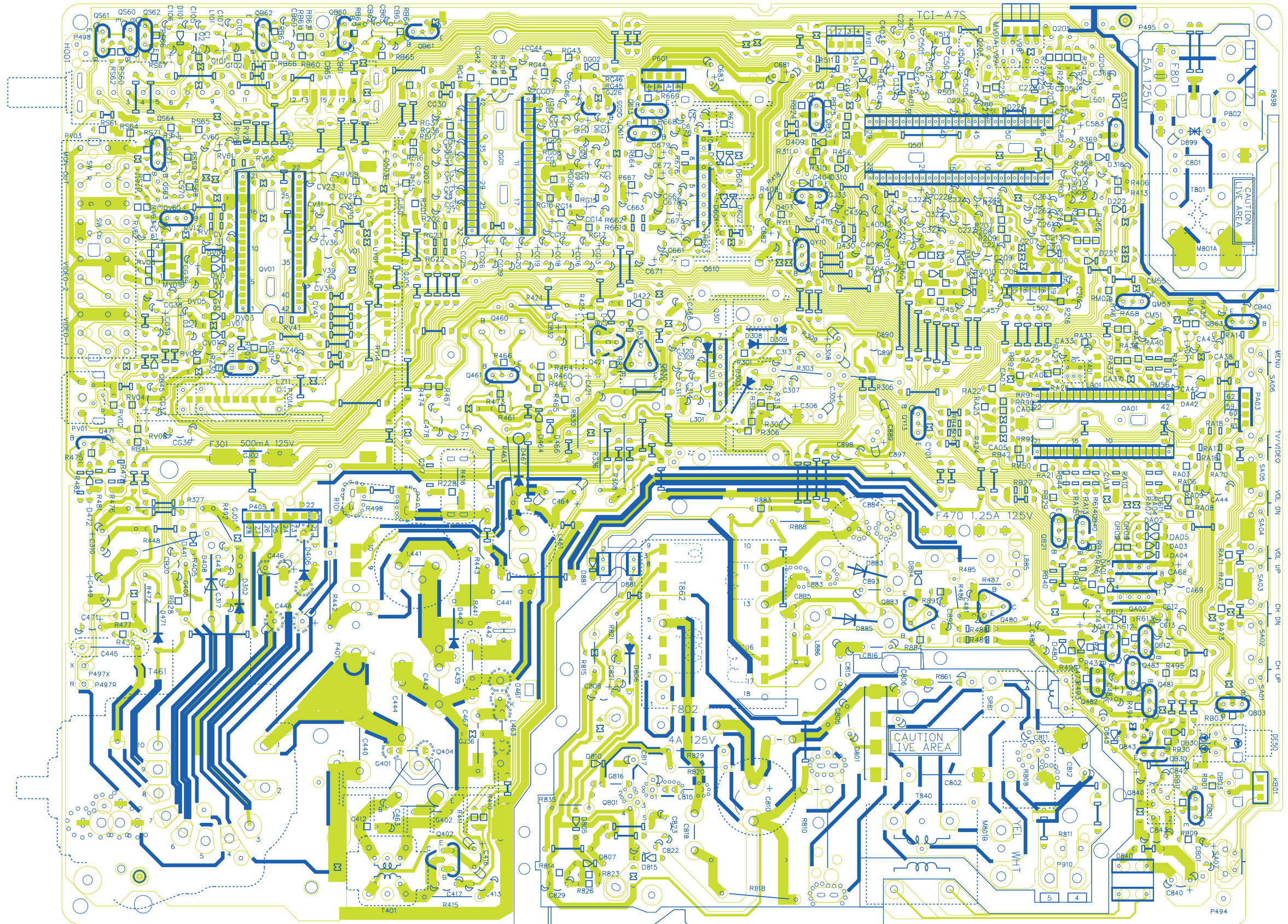

**CRT DRIVE BOARD PB8625B**  
BOTTOM (FOIL) SIDE

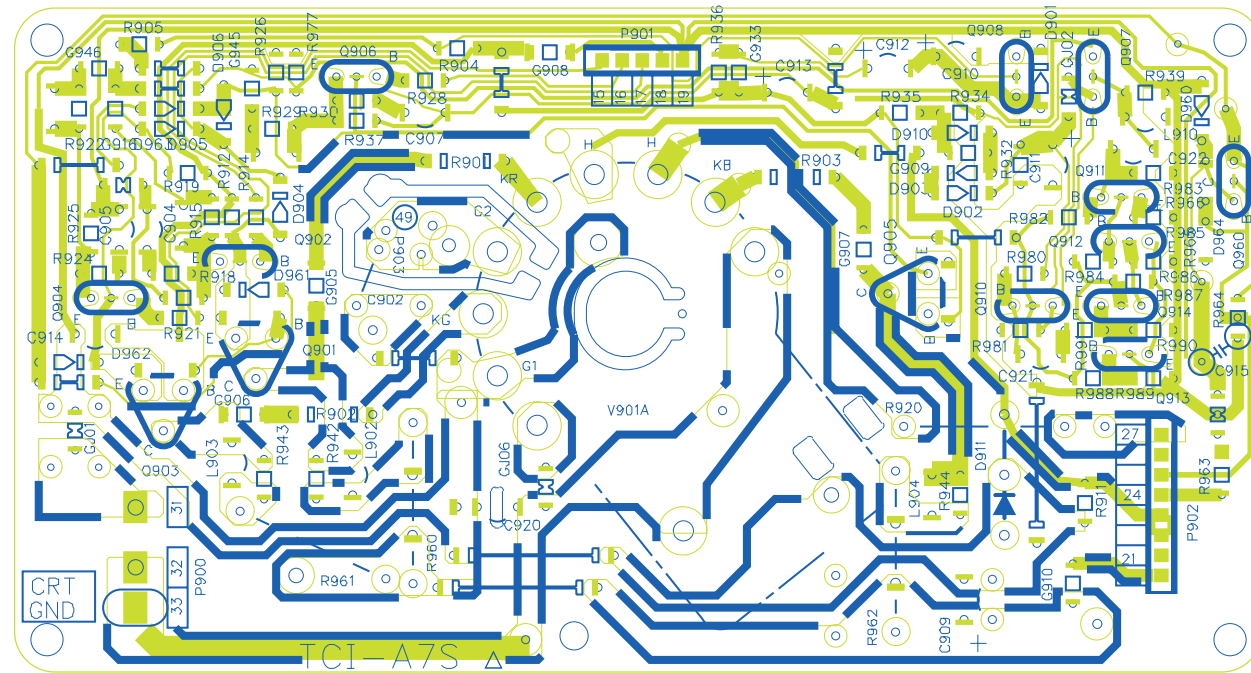

**PIP BOARD PB8622**  
BOTTOM (FOIL) SIDE

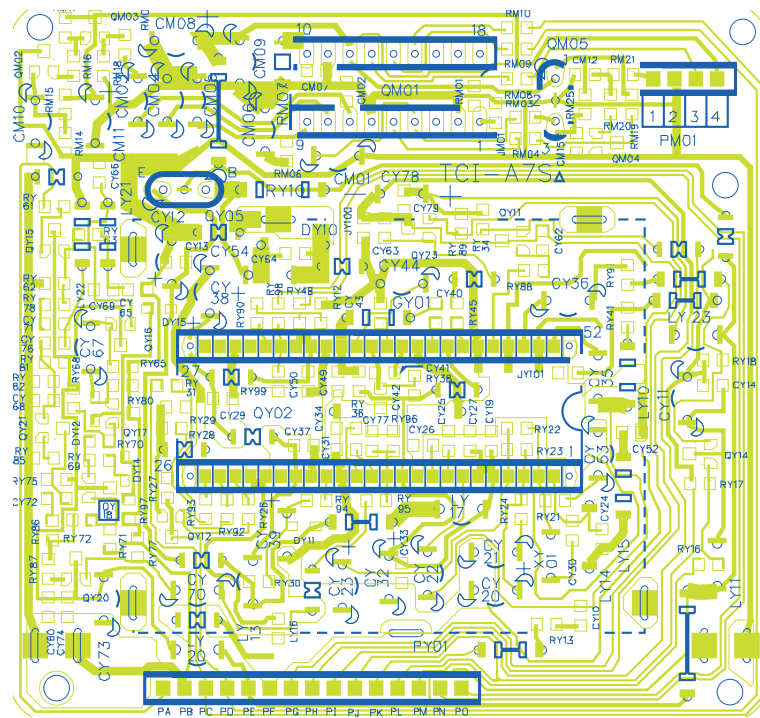

**DIGI-COMB BOARD PB9398**  
BOTTOM (FOIL) SIDE

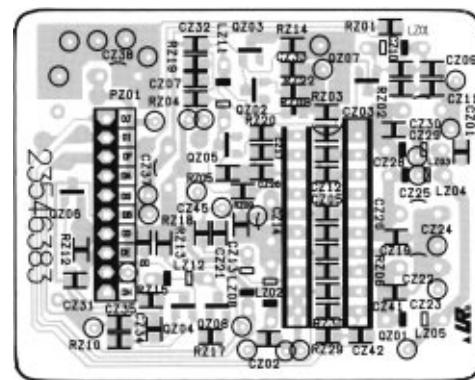

**TERMINAL VIEW OF TRANSISTORS**

- |                               |   |   |   |           |
|-------------------------------|---|---|---|-----------|
| ① 2SD2253<br>(old)<br>2SC5243 | ② 2SC3852<br>2SD1763A<br>2SC1569<br>2SC4544<br>2SA1788<br>2SA1306<br>2SA1186A | ③ 2SC752GTM<br>2SC2482<br>2SC2655<br>2SC4721P | ④ 2SC752<br>2SA562TM<br>2SA1015<br>2SC1815<br>2SC2878<br>2SC1740S<br>2SC2120<br>2SA9335 | ⑤ 2SA1788 |
|-------------------------------|---|---|---|-----------|

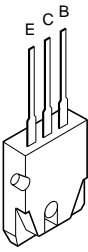
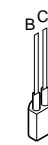
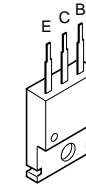
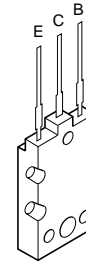

- ⑥ RN2203  
RN2201  
RN2004  
RN1203  
RN1204  
RN2204  
RN1205  
RN1202  
RN1201



- ⑦ 2SD1554  
2SD2253  
2SD1556  
2SC5143  
2SD2553

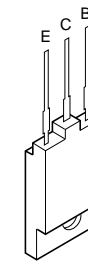

- ⑧ ON4409

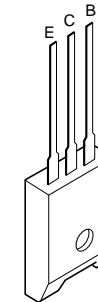





<b>SPECIFICATIONS</b>	
TELEVISION SYSTEM	NTSC standard
CHANNEL COVERAGE	VHF: 2 through 13 UHF: 14 through 69 Cable TV: mid band (A-8 through A-1, A through I) super band (J through W) hyper band (AA through ZZ, AAA, BBB) ultra band (65 through 94, 100 through 125)
POWER SOURCE	120V AC, 60Hz
POWER CONSUMPTION	90W (average)
AUDIO POWER	5W + 5W
SPEAKER TYPE	2-3/8 x 4-3/4 inches (60 x 120 mm)
VIDEO/AUDIO TERMINALS	S-VIDEO INPUT Y-INPUT: 1V(p-p), 75 ohm, negative sync. C-INPUT: 0.286V (p-p) (burst signal), 75 ohm AUDIO/VIDEO INPUT VIDEO: 1V(p-p), 75 ohm, negative sync. AUDIO: 150mV(rms) (30% modulation equivalent, 47k ohm) Color Stream™ (component video) INPUT Y: 1V(p-p), 75 ohm CR: 0.7V(p-p), 75 ohm CB: 0.7V(p-p), 75 ohm AUDIO/VIDEO OUTPUT VIDEO: 1V(p-p), 75 ohm, negative sync. AUDIO: 150mV(rms) (30% modulation equivalent, 4.7k ohm)
DIMENSIONS	Width        652 mm Height       600 mm Depth        526 mm
MASS	74.0 lbs
SUPPLIED ACCESSORIES	Remote Control with 2 size "AA" batteries

\*Please refer to owner's manual in detail.

**TOSHIBA CORPORATION**  
1-1, SHIBAURA 1-CHOME, MINATO-KU, TOKYO 105-8001, JAPAN



# SCHEMATIC DIAGRAM

**MODEL : 27A50    ChassisNo.TAC0012**

**WARNING:** BEFORE SERVICING THIS CHASSIS, READ THE "X-RAY RADIATION PRECAUTION", "SAFETY PRECAUTION" AND "PRODUCT SAFETY NOTICE" ON THE MANUAL FOR THIS MODEL.

**CAUTION:** The international hazard symbols " $\triangle$ " in the schematic diagram and the parts list designate components which have special characteristics important for safety and should be replaced only with types identical to those in the original circuit or specified in the parts list. The mounting position of replacements is to be identical with originals. Before replacing any of these components, read carefully the PRODUCT SAFETY NOTICE on the MANUAL for this model. Do not degrade the safety of the receiver through improper servicing.

**NOTE:**

- 1. RESISTOR**    Resistance is shown in ohm [K = 1.000, M = 1.000.000]. All resistors are 1/6W and 5% tolerance carbon resistor, unless otherwise noted as the following marks.  
1/2R = Metal or Metal oxide of 1/2 watt                      1/2S = Carbon composition of 1/2 watt  
1RF = Fuse resistor of 1 watt                                      10W = Cement of 10 watt  
K =  $\pm 10\%$     G =  $\pm 2\%$     F =  $\pm 1\%$
- 2. CAPACITOR**    Unless otherwise noted in schematic, all capacitor values less than 1 are expressed in  $\mu\text{F}$ , and the values more than 1 in pF.  
All capacitors are ceramic 50V, unless otherwise noted as the following marks.  
 Electrolytic capacitor                       Mylar capacitor
- 3.** The parts indicated with " $\triangle$ " have special characteristics, and should be replaced with identical parts only.
- 4.** Voltages read with DIGITAL MULTI-METER from point indicated to chassing ground, using a color bar signal with all controls at normal, line voltage 120 volts.
- 5.** Waveforms are taken receiving color bar signal with enough sensitivity.
- 6.** Voltage reading shown are nominal values and may vary  $\pm 20\%$  except H.V.

**WARNING:** BEFORE SERVICING THIS CHASSIS, READ THE "X-RAY RADIATION PRECAUTION", "SAFETY PRECAUTION" AND "PRODUCT SAFETY NOTICE" ON THE MANUAL FOR THIS MODEL.

**CAUTION:** The international hazard symbols "△" in the schematic diagram and the parts list designate components which have special characteristics important for safety and should be replaced only with types identical to those in the original circuit or specified in the parts list. The mounting position of replacements is to be identical with originals. Before replacing any of these components, read carefully the PRODUCT SAFETY NOTICE on the MANUAL for this model. Do not degrade the safety of the receiver through improper servicing.

**NOTE:**

- RESISTOR**  
Resistance is shown in ohm [K = 1,000, M = 1,000,000]. All resistors are 1/6W and 5% tolerance carbon resistor, unless otherwise noted as the following marks.  
1/2R = Metal or Metal oxide of 1/2 watt  
1RF = Fuse resistor of 1 watt  
K = ±10% G = ±2% F = ±1%
- CAPACITOR**  
Unless otherwise noted in schematic, all capacitor values less than 1 are expressed in µF, and the values more than 1 in pF.  
All capacitors are ceramic 50V, unless otherwise noted as the following marks.  
—|— Electrolytic capacitor  
—|— Mylar capacitor
- The parts indicated with "△" have special characteristics, and should be replaced with identical parts only.

4. Voltages read with DIGITAL MULTI-METER from point indicated to chassis ground, using a color bar signal with all controls at normal, line voltage 120 volts.
5. Waveforms are taken receiving color bar signal with enough sensitivity.
6. Voltage reading shown are nominal values and may vary ±20% except H.V.

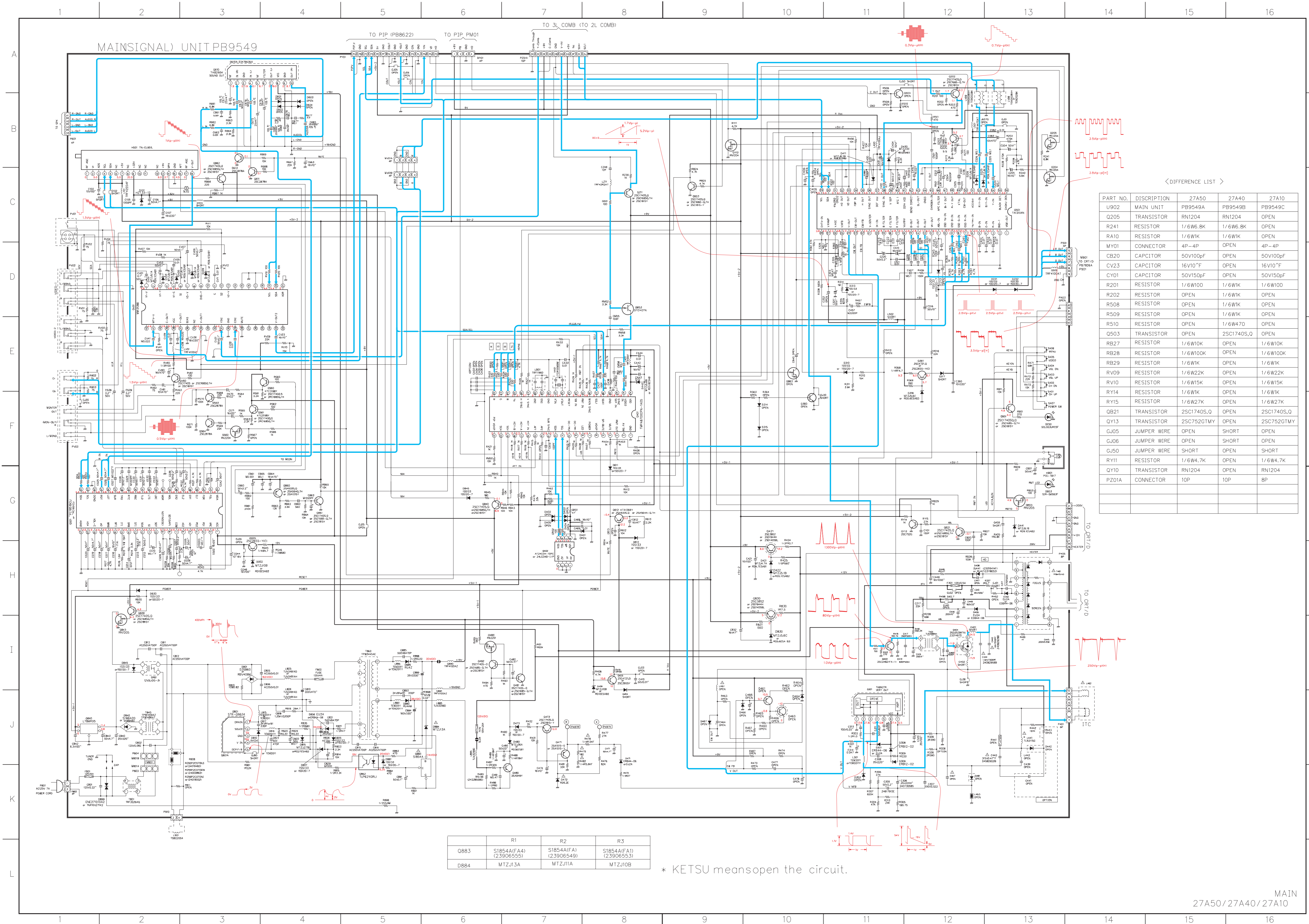

< DIFFERENCE LIST >

PART NO.	DISCRIPTION	27A50	27A40	27A10
U902	MAIN UNIT	PB9549A	PB9549B	PB9549C
Q205	TRANSISTOR	RN1204	RN1204	OPEN
R241	RESISTOR	1/6W6.8K	1/6W6.8K	OPEN
RA10	RESISTOR	1/6WK	1/6WK	OPEN
MY01	CONNECTOR	4P-4P	OPEN	4P-4P
CB20	CAPACITOR	50V100pF	OPEN	50V100pF
CV23	CAPACITOR	16V10 <sup>3</sup> F	OPEN	16V10 <sup>3</sup> F
CY01	CAPACITOR	50V150pF	OPEN	50V150pF
R201	RESISTOR	1/6W100	1/6WK	1/6W100
R202	RESISTOR	OPEN	1/6WK	OPEN
R508	RESISTOR	OPEN	1/6WK	OPEN
R509	RESISTOR	OPEN	1/6WK	OPEN
R510	RESISTOR	OPEN	1/6W470	OPEN
Q503	TRANSISTOR	OPEN	2SC1740S,Q	OPEN
RB27	RESISTOR	1/6W10K	OPEN	1/6W10K
RB28	RESISTOR	1/6W100K	OPEN	1/6W100K
RB29	RESISTOR	1/6WK	OPEN	1/6WK
RV09	RESISTOR	1/6W22K	OPEN	1/6W22K
RV10	RESISTOR	1/6W15K	OPEN	1/6W15K
RY14	RESISTOR	1/6WK	OPEN	1/6WK
RY15	RESISTOR	1/6W27K	OPEN	1/6W27K
QB21	TRANSISTOR	2SC1740S,D	OPEN	2SC1740S,Q
QY13	TRANSISTOR	2SC7520TMY	OPEN	2SC7520TMY
J05	JUMPER WIRE	OPEN	SHORT	OPEN
J06	JUMPER WIRE	OPEN	SHORT	OPEN
J05	JUMPER WIRE	SHORT	OPEN	SHORT
RY11	RESISTOR	1/6W4.7K	OPEN	1/6W4.7K
QY10	TRANSISTOR	RN1204	OPEN	RN1204
P201A	CONNECTOR	10P	10P	8P

	R1	R2	R3
Q883	S1854A(FA4)	S1854A(FA1)	S1854A(FA1)
	(23906553)	(23906549)	(23906553)
D884	MTZJ13A	MTZJ11A	MTZJ09

\* KETSU means open the circuit.

# MAINSIGNAL) UNIT PB9549

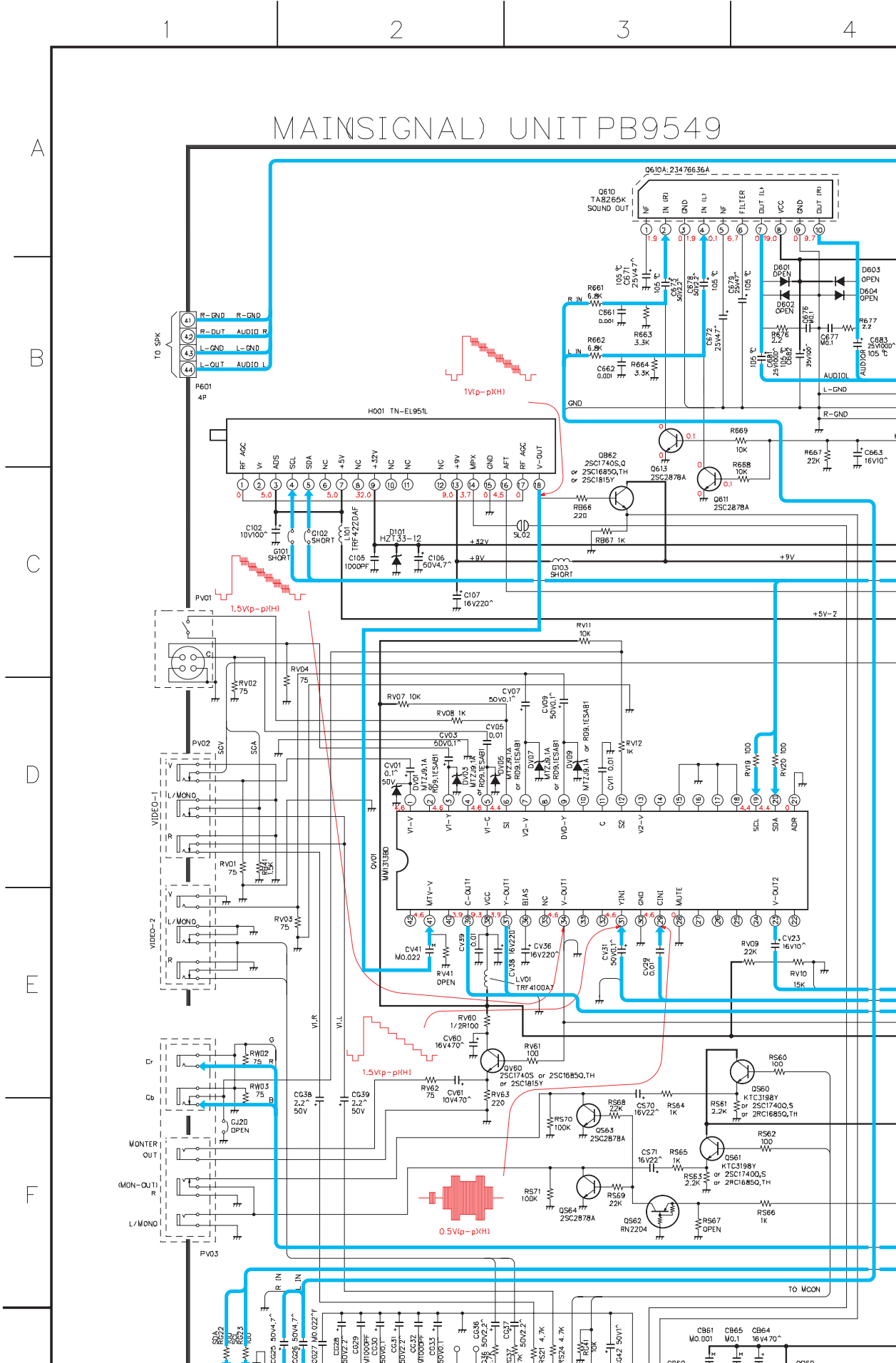





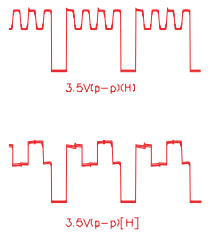
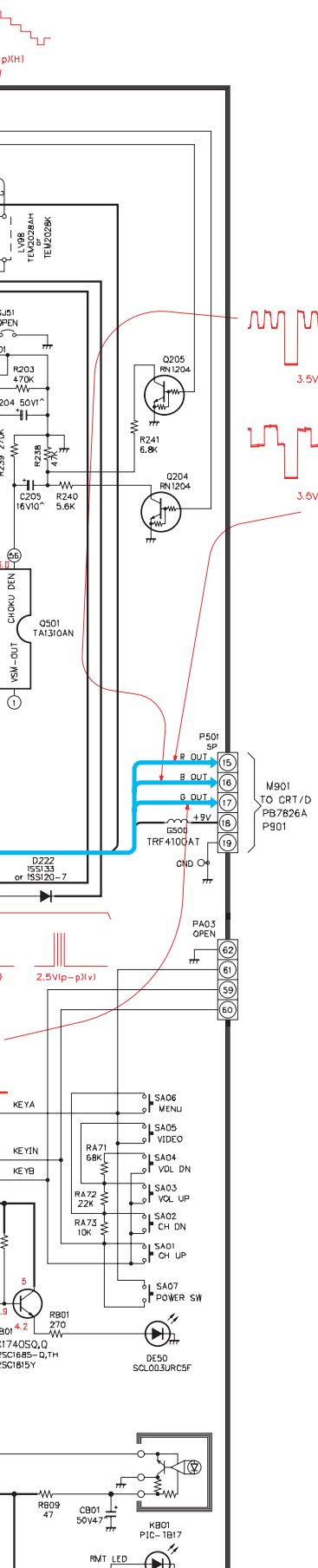

< DIFFERENCE LIST >

PART NO.	DISCRIPTION	27A50	27A40	27A10
U902	MAIN UNIT	PB9549A	PB9549B	PB9549C
Q205	TRANSISTOR	RN1204	RN1204	OPEN
R241	RESISTOR	1/6W6.8K	1/6W6.8K	OPEN
RA10	RESISTOR	1/6W1K	1/6W1K	OPEN
MY01	CONNECTOR	4P-4P	OPEN	4P-4P
CB20	CAPCITOR	50V100pF	OPEN	50V100pF
CV23	CAPCITOR	16V10 <sup>μ</sup> F	OPEN	16V10 <sup>μ</sup> F
CY01	CAPCITOR	50V150pF	OPEN	50V150pF
R201	RESISTOR	1/6W100	1/6W1K	1/6W100
R202	RESISTOR	OPEN	1/6W1K	OPEN
R508	RESISTOR	OPEN	1/6W1K	OPEN
R509	RESISTOR	OPEN	1/6W1K	OPEN
R510	RESISTOR	OPEN	1/6W470	OPEN
Q503	TRANSISTOR	OPEN	2SC1740S,Q	OPEN
RB27	RESISTOR	1/6W10K	OPEN	1/6W10K
RB28	RESISTOR	1/6W100K	OPEN	1/6W100K
RB29	RESISTOR	1/6W1K	OPEN	1/6W1K
RV09	RESISTOR	1/6W22K	OPEN	1/6W22K
RV10	RESISTOR	1/6W15K	OPEN	1/6W15K
RY14	RESISTOR	1/6W1K	OPEN	1/6W1K
RY15	RESISTOR	1/6W27K	OPEN	1/6W27K
QB21	TRANSISTOR	2SC1740S,Q	OPEN	2SC1740S,Q
QY13	TRANSISTOR	2SC752GTMY	OPEN	2SC752GTMY
GJ05	JUMPER WIRE	OPEN	SHORT	OPEN
GJ06	JUMPER WIRE	OPEN	SHORT	OPEN
GJ50	JUMPER WIRE	SHORT	OPEN	SHORT
RY11	RESISTOR	1/6W4.7K	OPEN	1/6W4.7K
QY10	TRANSISTOR	RN1204	OPEN	RN1204
PZ01A	CONNECTOR	10P	10P	8P

A

B

C

D

E

F



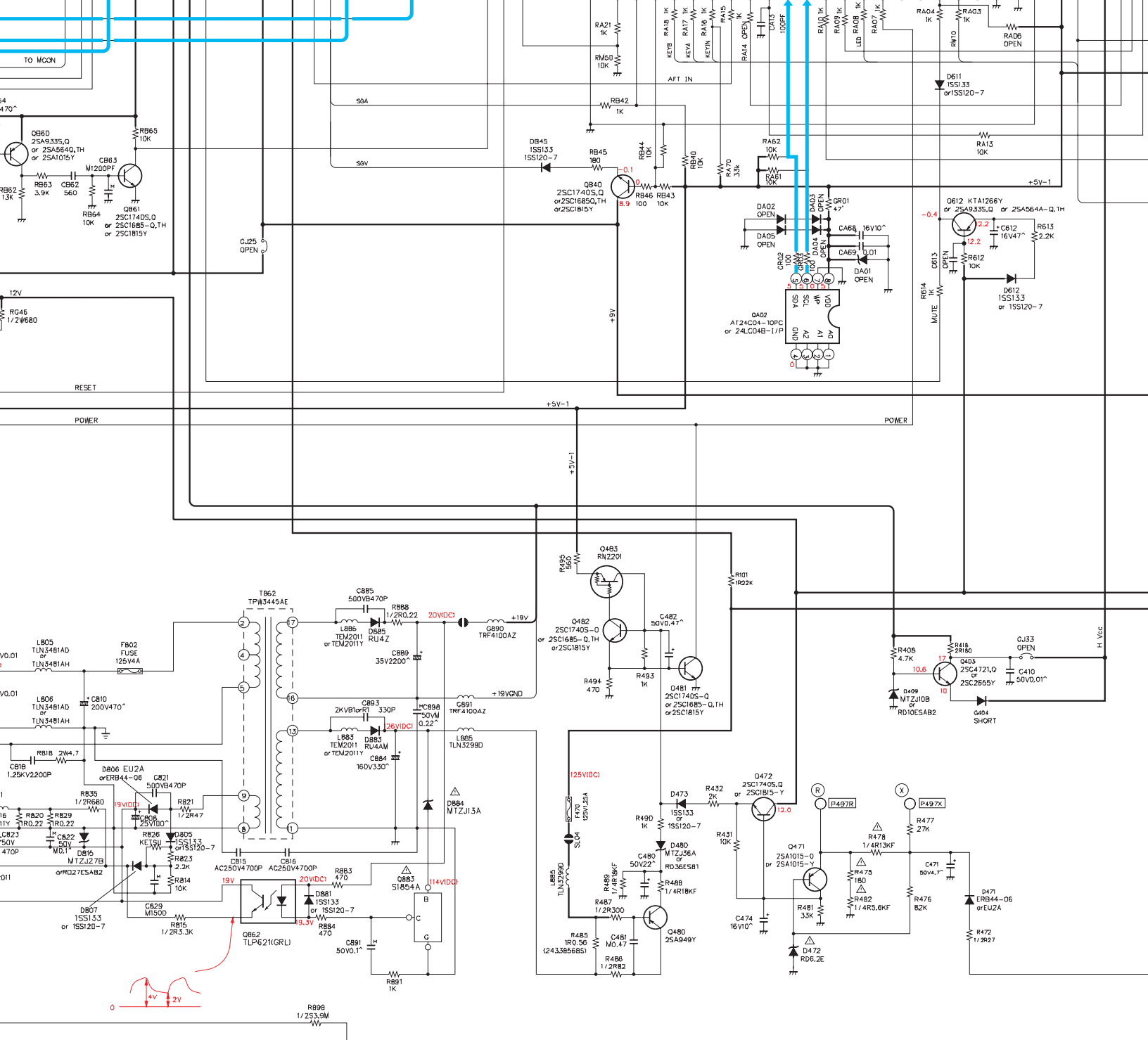

	R1	R2	R3
Q883	S1854A(FA4) (23906555)	S1854A(FA) (23906549)	S1854A(FA1) (23906553)
D884	MTZJ13A	MTZJ11A	MTZJ10B

\* KE



GJ06	JUMPER WIRE	OPEN	SHORT	OPEN
GJ50	JUMPER WIRE	SHORT	OPEN	SHORT
RY11	RESISTOR	1/6W4.7K	OPEN	1/6W4.7K
QY10	TRANSISTOR	RN1204	OPEN	RN1204
PZ01A	CONNECTOR	10P	10P	8P

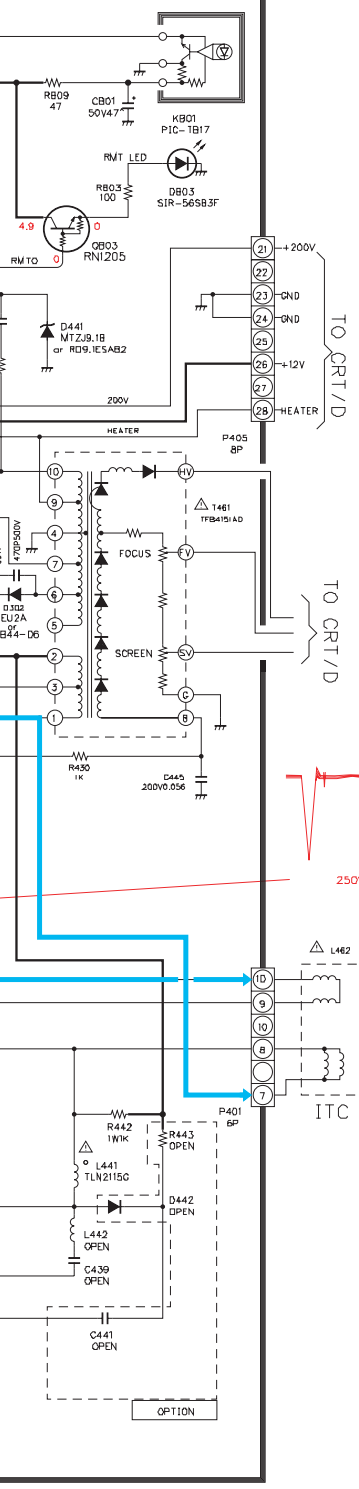

G

H

I

J

K

L

MAIN  
27A50/27A40/27A10

13

14

15

16

U901 CRT DRIVE PB8625B

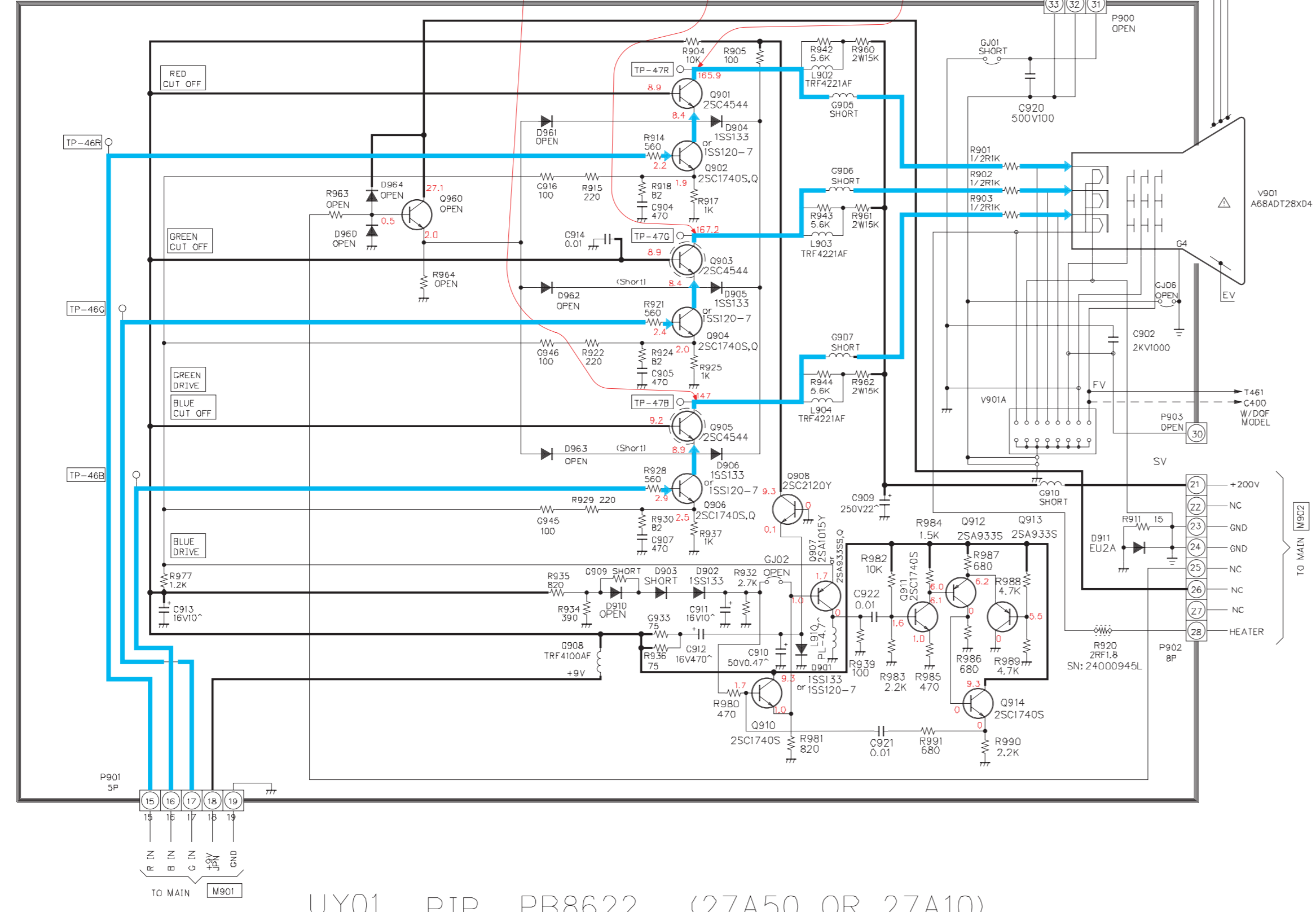

DIGITAL COME FILTER(3LINE) PB9398 (27A50 OR 27A40)

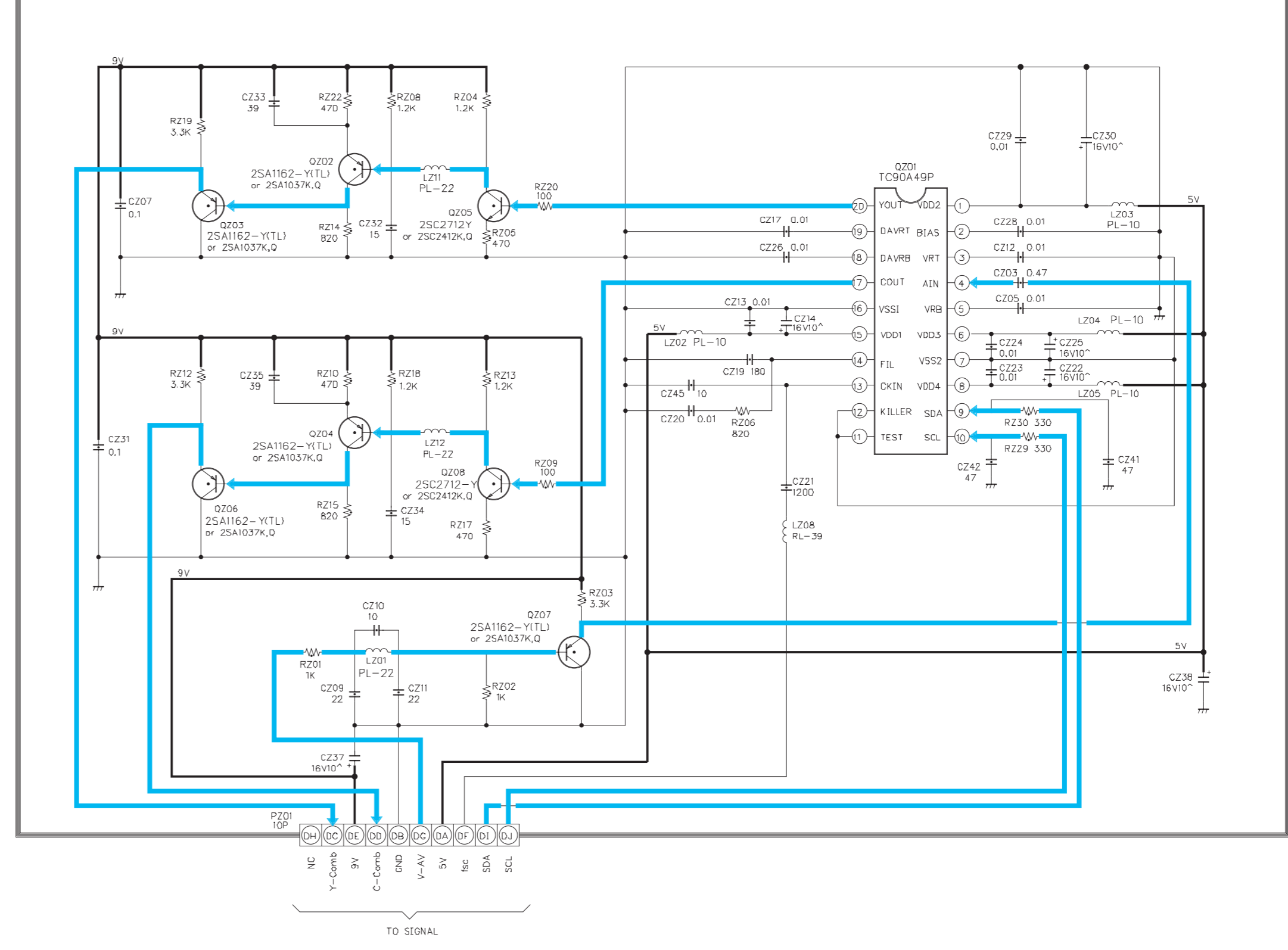

UY01 PIP PB8622 (27A50 OR 27A10)

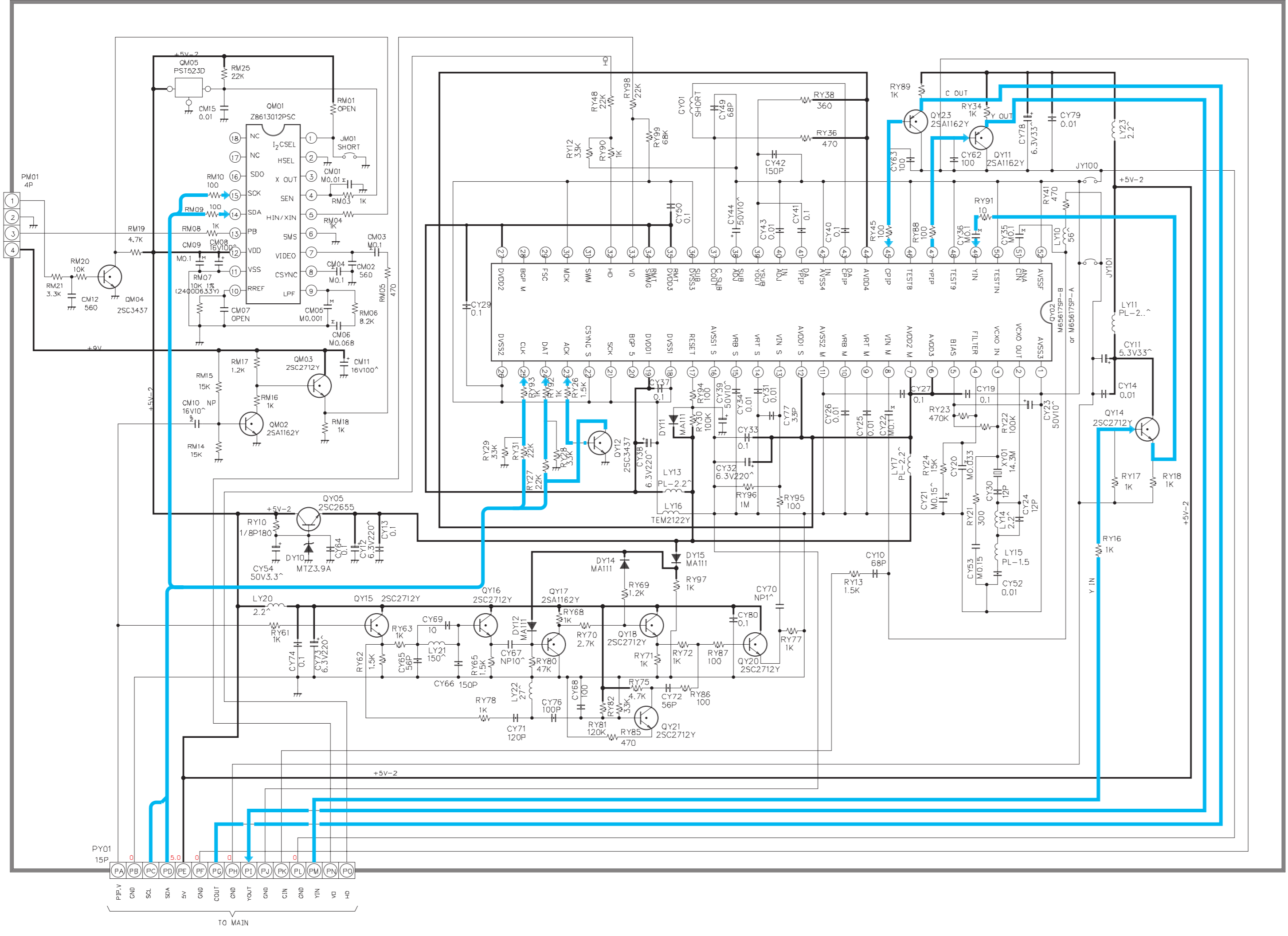

DIGITAL COMB FILTER(2LINE) PB8689 (27A10)

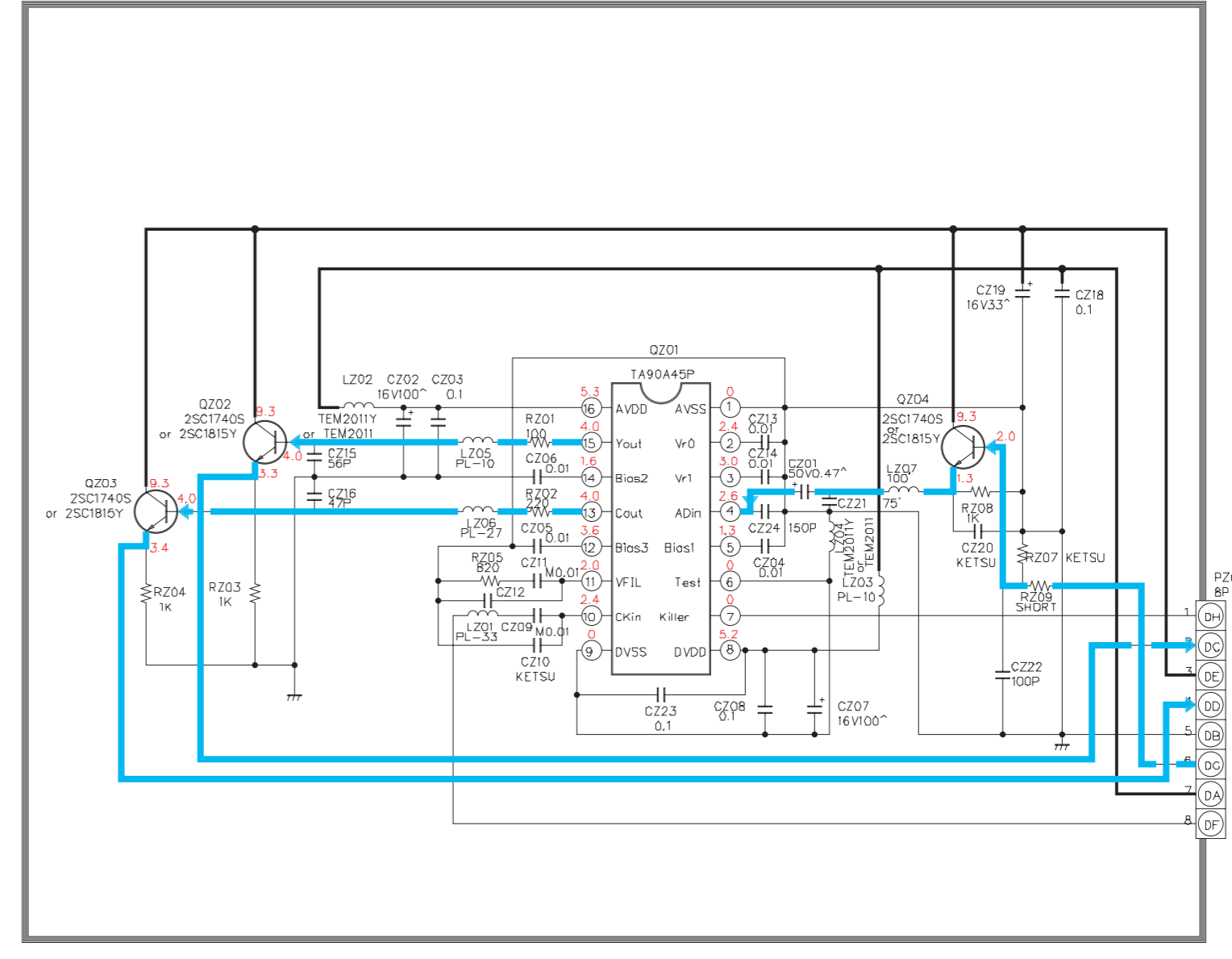

PIP/CRT-DRIVE  
27A50/27A40  
/27A10

1

2

3

A

B

C

D

# U901 CRT DRIVE PB8625B

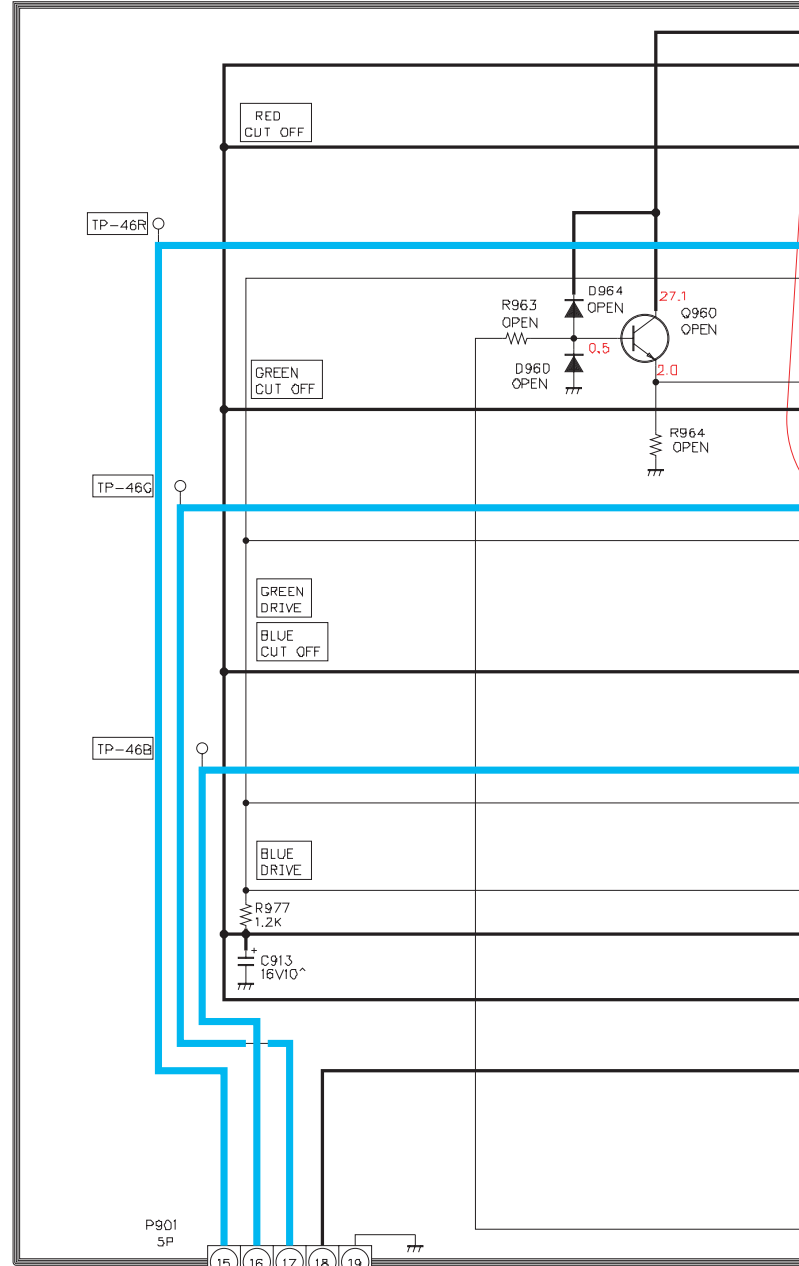

P901  
5P

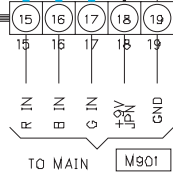

# UY01 PIP

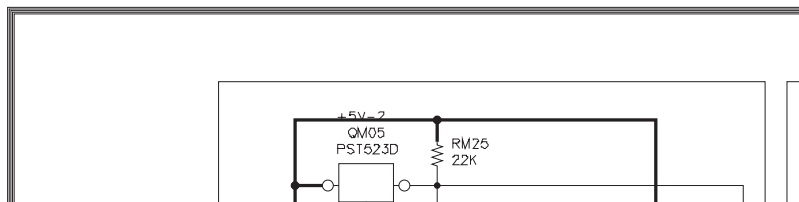

3

4

5

6

8625B

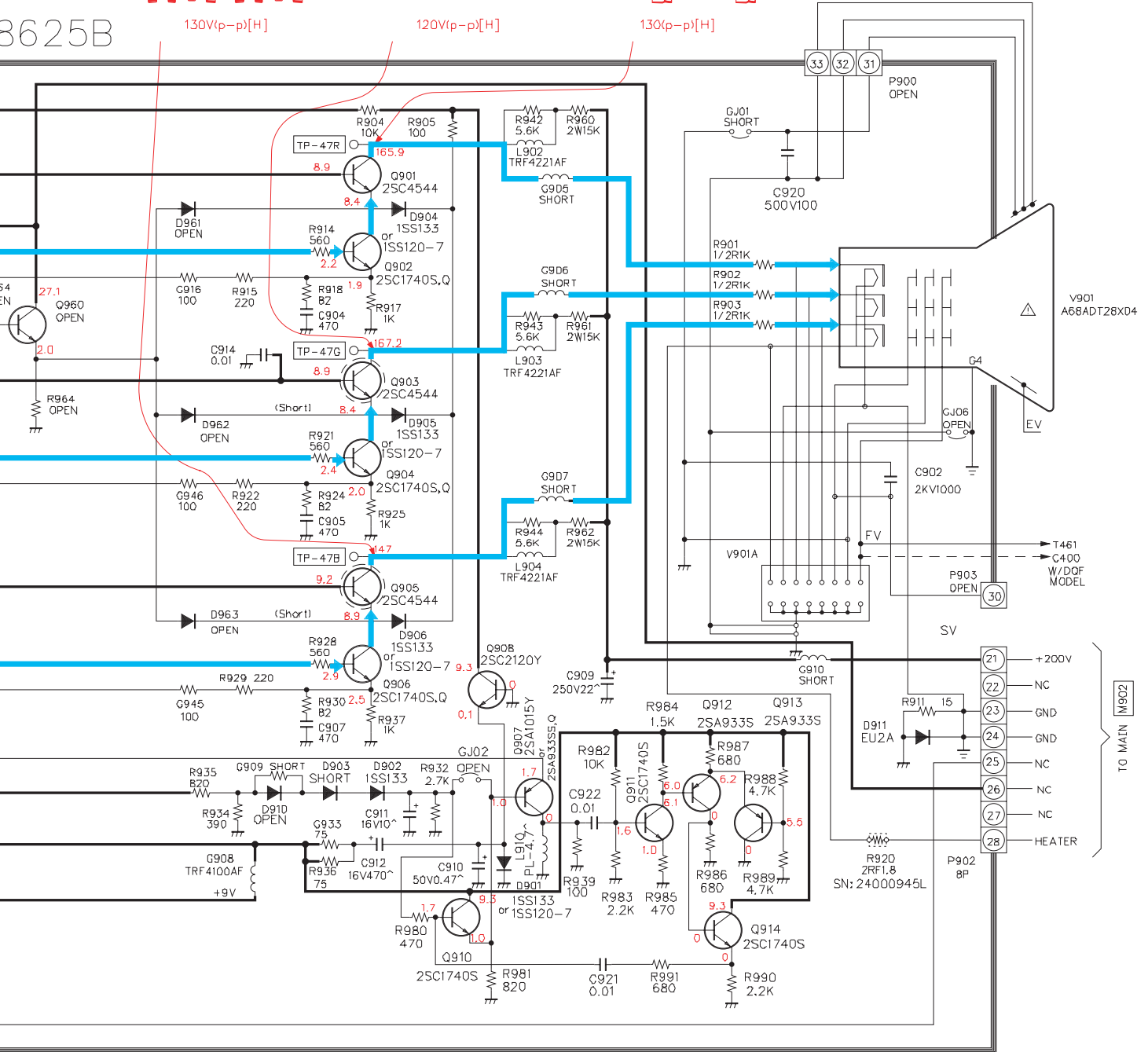

PIP PB8622 (27A50 OR 27A10)

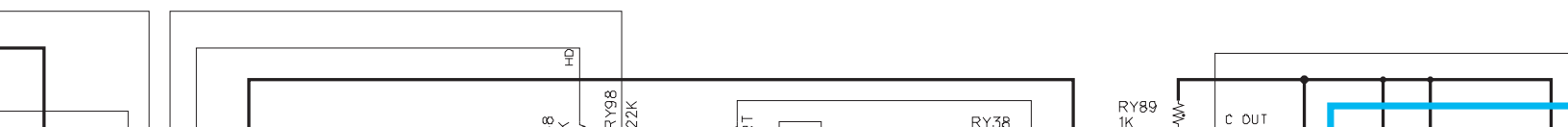

# DIGITAL COME FILTER(3LINE)

PB9398 ( 27A50

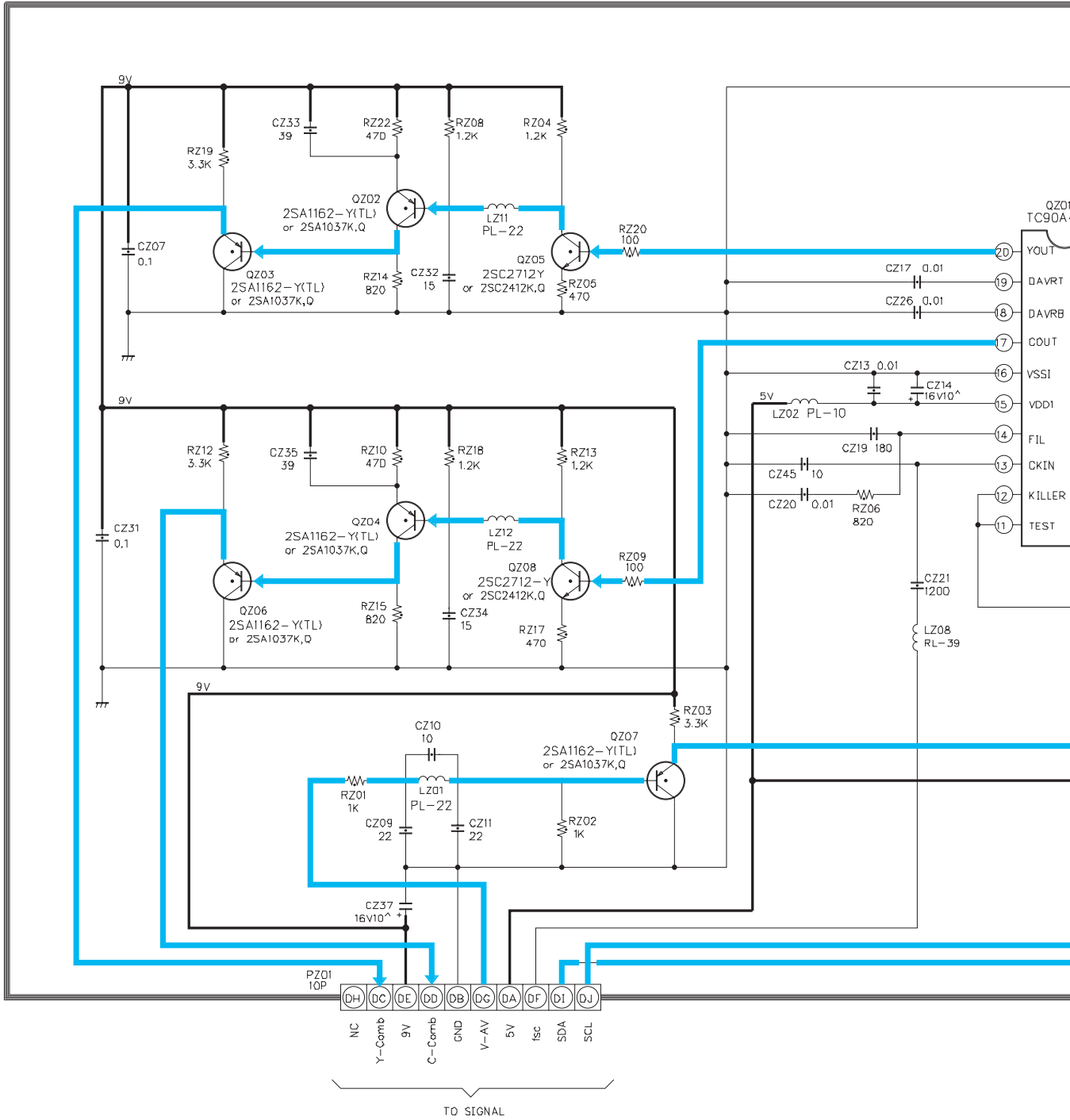

10

11

12

( 27A50 OR 27A40)

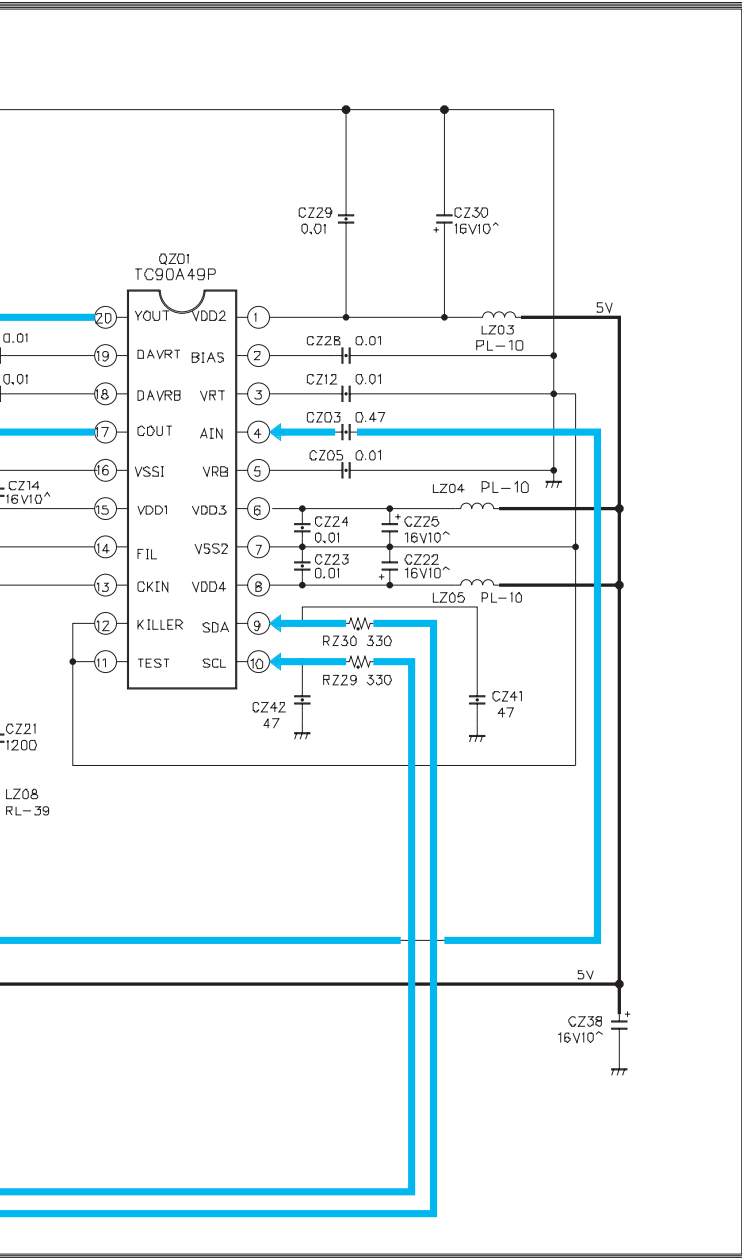

A

B

C

D

( INF)

PR8689 (27A10)

E

F

G

H

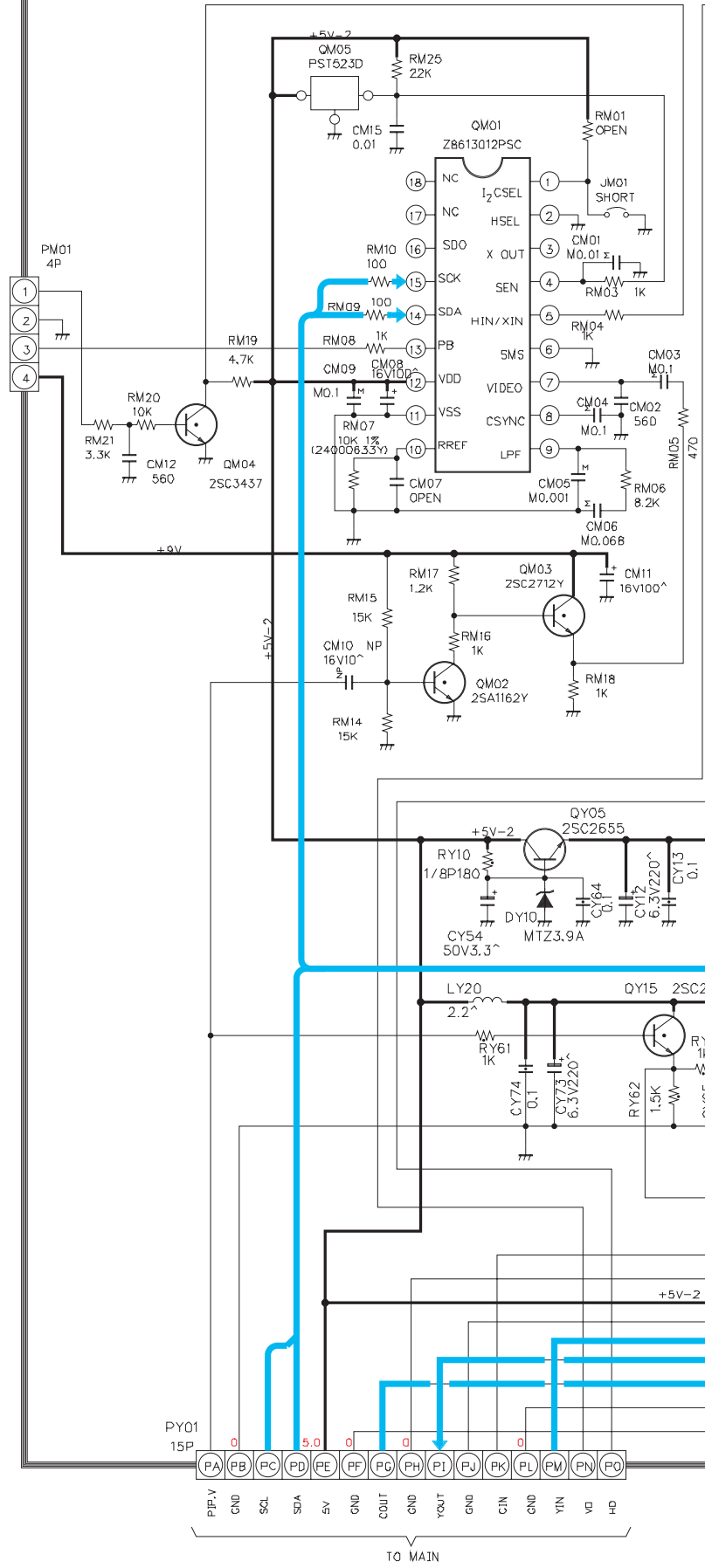

1

2

3

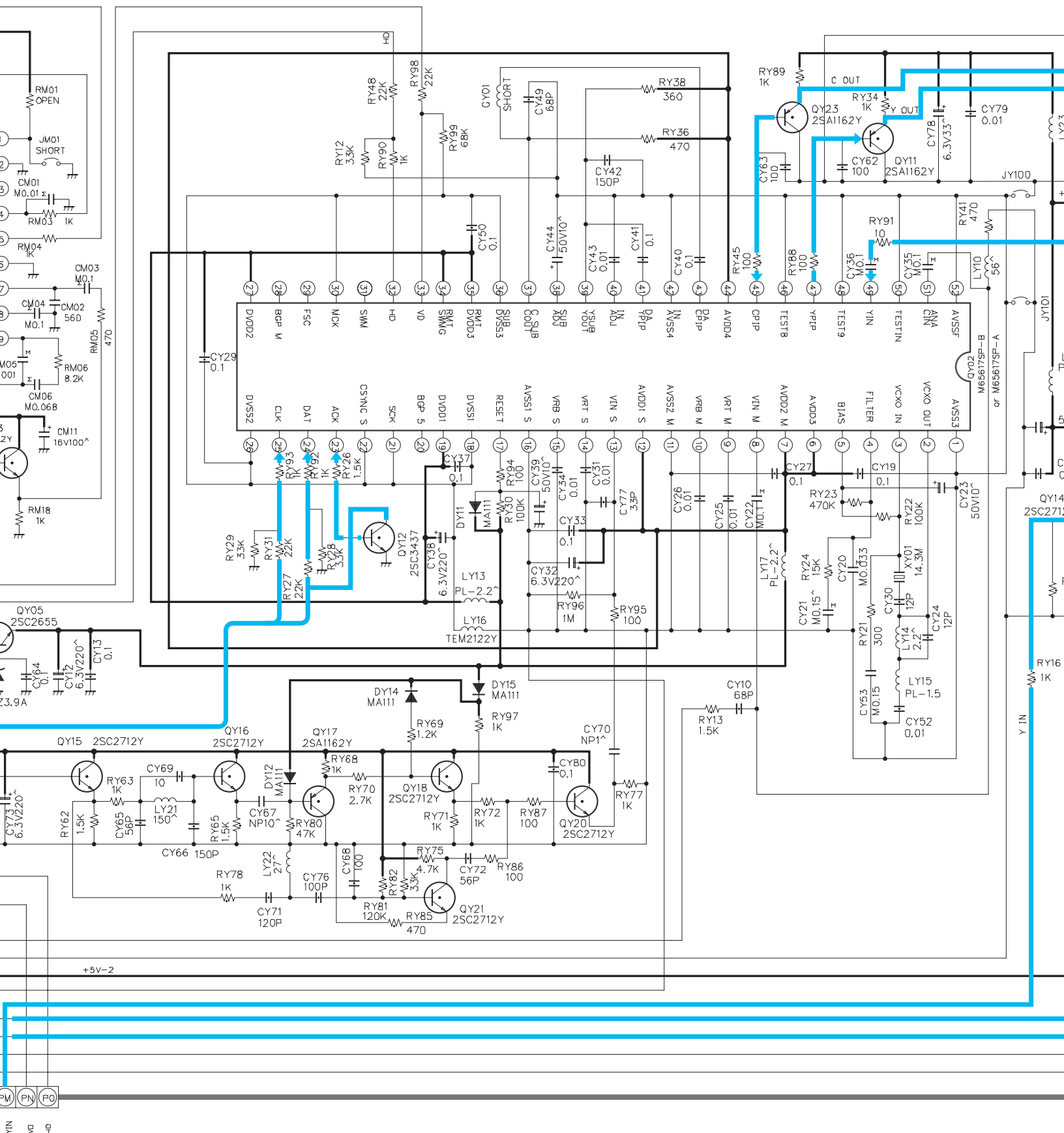

3 4 5 6

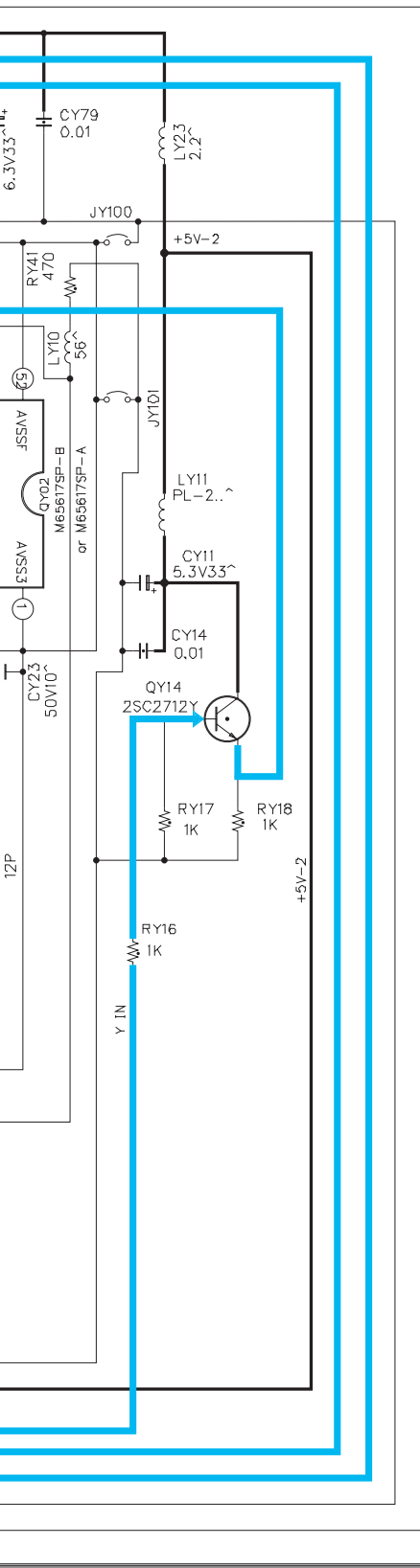

# DIGITAL COMB FILTER(2LINE)

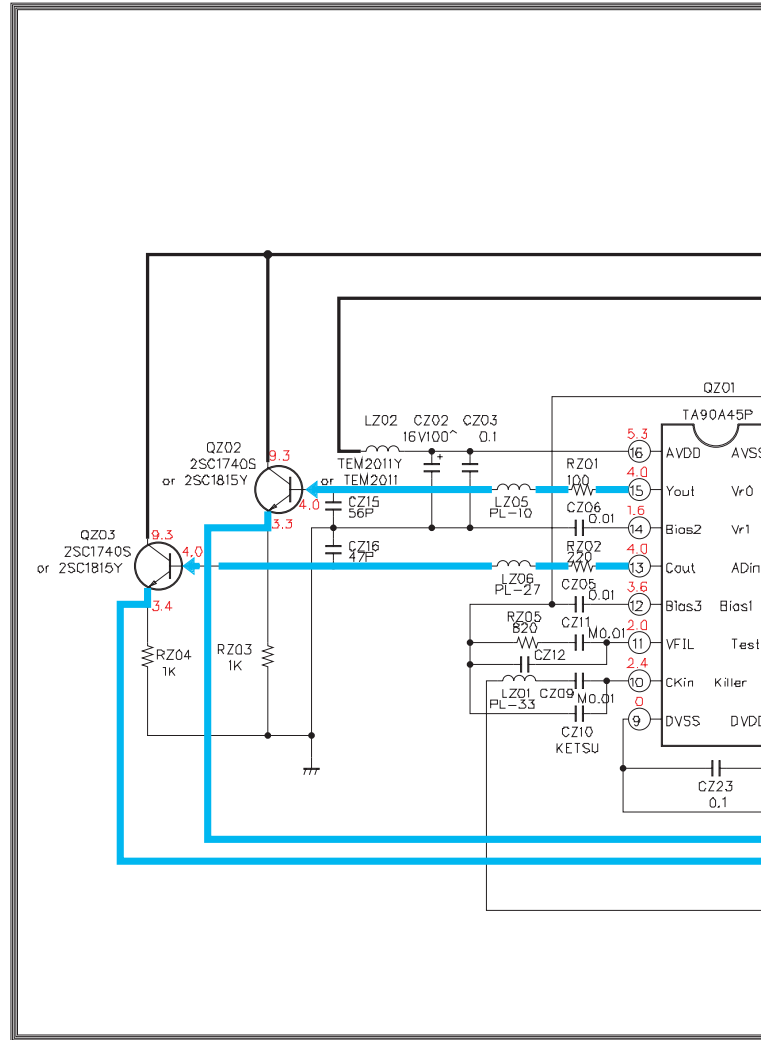

LINE) PB8689 (27A10)

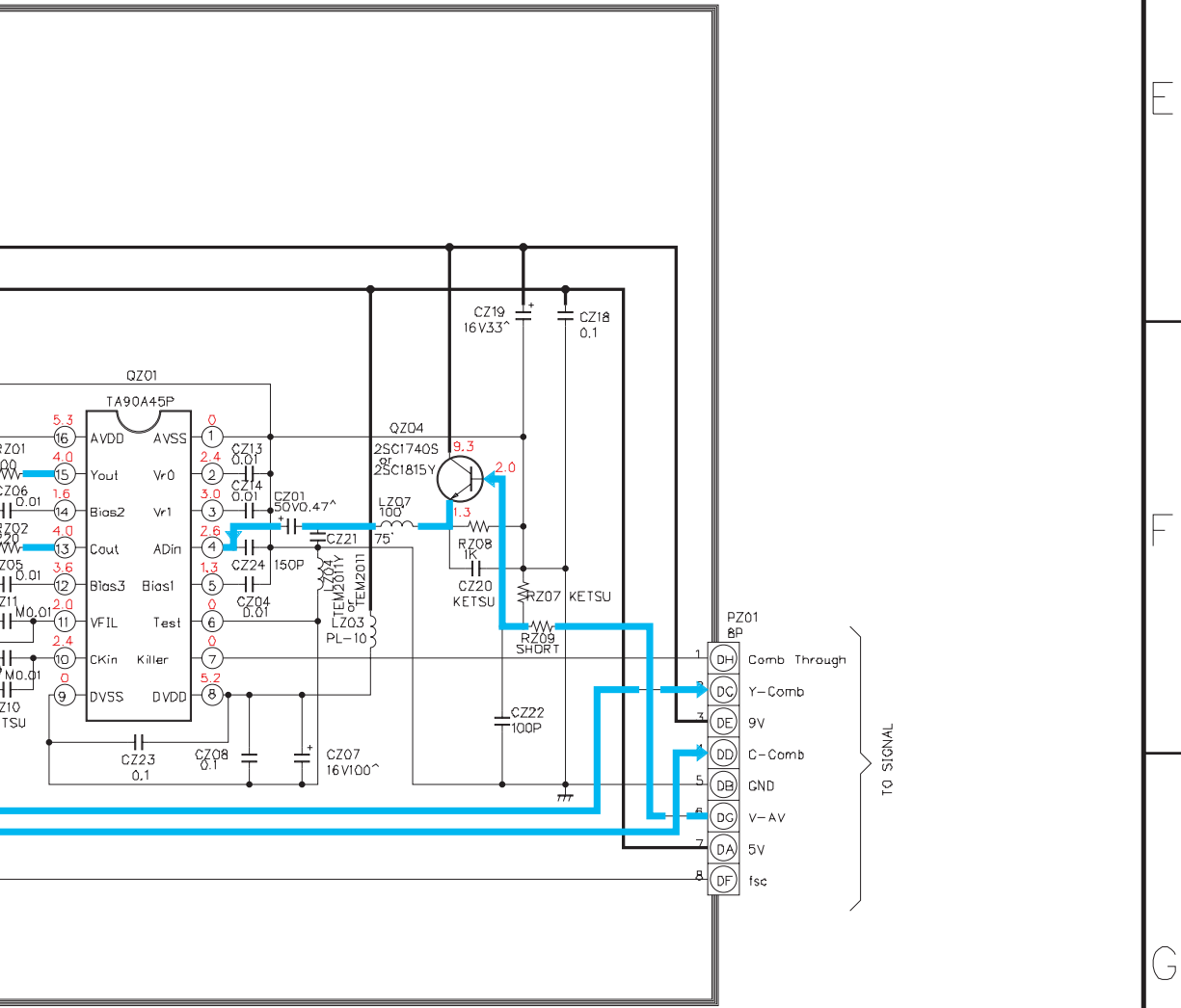

PIP / CRT-DRIVE  
27A50 / 27A40  
/ 27A10

10

11

12

E  
F  
G  
H