

TOSHIBA

FILE NO. 050-200521
(MFR'S VERSION A)

SERVICE MANUAL

COLOR TELEVISION

27A35C

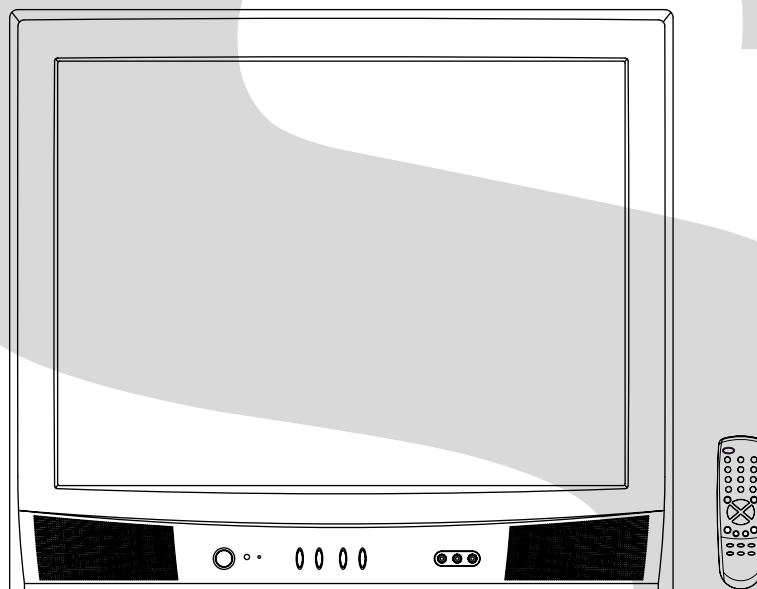

SERVICING NOTICES ON CHECKING

1. KEEP THE NOTICES

As for the places which need special attentions, they are indicated with the labels or seals on the cabinet, chassis and parts. Make sure to keep the indications and notices in the operation manual.

2. AVOID AN ELECTRIC SHOCK

There is a high voltage part inside. Avoid an electric shock while the electric current is flowing.

3. USE THE DESIGNATED PARTS

The parts in this equipment have the specific characters of incombustibility and withstand voltage for safety. Therefore, the part which is replaced should be used the part which has the same character.

Especially as to the important parts for safety which is indicated in the circuit diagram or the table of parts as a  mark, the designated parts must be used.

4. PUT PARTS AND WIRES IN THE ORIGINAL POSITION AFTER ASSEMBLING OR WIRING

There are parts which use the insulation material such as a tube or tape for safety, or which are assembled in the condition that these do not contact with the printed board. The inside wiring is designed not to get closer to the pyrogenic parts and high voltage parts. Therefore, put these parts in the original positions.

5. TAKE CARE TO DEAL WITH THE CATHODE-RAY TUBE

In the condition that an explosion-proof cathode-ray tube is set in this equipment, safety is secured against implosion. However, when removing it or serving from backward, it is dangerous to give a shock. Take enough care to deal with it.

6. AVOID AN X-RAY

Safety is secured against an X-ray by considering about the cathode-ray tube and the high voltage peripheral circuit, etc.

Therefore, when repairing the high voltage peripheral circuit, use the designated parts and make sure not modify the circuit.

Repairing except indicates causes rising of high voltage, and it emits an X-ray from the cathode-ray tube.

7. PERFORM A SAFETY CHECK AFTER SERVICING

Confirm that the screws, parts and wiring which were removed in order to service are put in the original positions, or whether there are the portions which are deteriorated around the serviced places serviced or not. Check the insulation between the antenna terminal or external metal and the AC cord plug blades. And be sure the safety of that.

(INSULATION CHECK PROCEDURE)

1. Unplug the plug from the AC outlet.
2. Remove the antenna terminal on TV and turn on the TV.
3. Insulation resistance between the cord plug terminals and the external exposure metal **[Note 2]** should be more than 1M ohm by using the 500V insulation resistance meter **[Note 1]**.
4. If the insulation resistance is less than 1M ohm, the inspection repair should be required.

[Note 1]

If you have not the 500V insulation resistance meter, use a Tester.

[Note 2]

External exposure metal: Antenna terminal
Earphone jack

HOW TO ORDER PARTS

Please include the following informations when you order parts. (Particularly the VERSION LETTER.)

1. MODEL NUMBER and VERSION LETTER

The MODEL NUMBER can be found on the back of each product and the VERSION LETTER can be found at the end of the SERIAL NUMBER.

2. PART NO. and DESCRIPTION

You can find it in your SERVICE MANUAL.

IMPORTANT

Inferior silicon grease can damage IC's and transistors.

When replacing an IC's or transistors, use only specified silicon grease (YG6260M).

Remove all old silicon before applying new silicon.

TABLE OF CONTENTS

SERVICING NOTICES ON CHECKING	A1-1
HOW TO ORDER PARTS	A1-1
IMPORTANT	A1-1
TABLE OF CONTENTS	A2-1
GENERAL SPECIFICATIONS	A3-1~A3-5
DISASSEMBLY INSTRUCTIONS	
1. REMOVAL OF ANODE CAP	B1-1
2. REMOVAL AND INSTALLATION OF FLAT PACKAGE IC	B2-1, B2-2
SERVICE MODE LIST	C1-1
CONFIRMATION OF HOURS USED	C1-1
WHEN REPLACING EEPROM (MEMORY) IC	C1-1
ELECTRICAL ADJUSTMENTS	D-1~D-6
BLOCK DIAGRAMS	E-1, E-2
PRINTED CIRCUIT BOARDS	
MAIN/CRT	F-1~F-4
SCHEMATIC DIAGRAMS	
MICON	G-1, G-2
CHROMA	G-3, G-4
DEFLECTION	G-5, G-6
POWER	G-7, G-8
SOUND	G-9, G-10
TUNER/STEREO	G-11, G-12
COMB/FILTER	G-13, G-14
CRT	G-15, G-16
WAVEFORMS	H-1, H-2
MECHANICAL EXPLODED VIEWS	I-1, I-2
MECHANICAL REPLACEMENT PARTS LIST	J1-1
ELECTRICAL REPLACEMENT PARTS LIST	J2-1~J2-4

GENERAL SPECIFICATIONS

G-1	TV System	CRT	CRT Size / Visual Size	27 inch / 676mmV
			CRT Type	Normal
			Magnetic Field BV/BH	+0.45G/0.18G
		Color System		NTSC
		Speaker		2Speaker
			Position	Front
			Size	2.0 x 3.5 Inch
			Impedance	8 ohm
		Sound Output	MAX	2.5 + 2.5 W
			10%(Typical)	- W
		NTSC3.58+4.43 /PAL60Hz	No	
G-2	Tuning System	Broadcasting System		US System M
		Tuner and Receive CH	System	1Tuner
			Destination	USA(W/ CATV)
			CH Coverage	2 - 69, 4A, A-5 - A-1, A - I, J - W, W+1 - W+84
		Intermediate Frequency	Picture(FP)	45.75MHz
			Sound(FS)	41.25MHz
			FP-FS	4.50MHz
		Preset CH		No
		Stereo/Dual TV Sound		Yes
Tuner Sound Muting		Yes		
G-3	Power	Power Source	AC	120V AC 60Hz
			DC	-
		Power Consumption		at AC
			Stand by (at AC)	125 W at AC 120 V 60 Hz
			Per Year	3 W at AC 120 V 60 Hz
			-- kWh/Year	
	Protector	Power Fuse	Yes	
		Safety Circuit	Yes	
		IC Protector(Micro Fuse)	No	
G-4	Regulation	Safety		CSA
		Radiation		IC
		X-Radiation		HWC
G-5	Temperature	Operation		+5oC ~ +40oC
		Storage		-20oC ~ +60oC
G-6	Operating Humidity			Less than 80% RH

GENERAL SPECIFICATIONS

G-7	On Screen Display	Menu	Menu Type	Yes		
			Icon	Yes		
			Picture	Yes		
			Contrast	Yes		
			Brightness	Yes		
			Color	Yes		
			Tint	Yes		
			Sharpness	Yes		
			Audio	Yes		
			Bass	Yes		
			Treble	Yes		
			Balance	Yes		
			BBE On/Off		No	
			Stable Sound On/Off	Yes		
			Surround On/Off	Yes		
			Set Up	Yes		
			TV/CABLE(CATV)	Yes		
			CH Program	Yes		
			Add/Erase	Yes		
			Option	Yes		
			Language	Yes		
			V-chip		No	
			CH Label	Yes		
			Favorite CH	Yes		
			Lock	Yes		
			On/Off Timer	Yes		
			Color Stream DVD/DTV	Yes		
			Control Level	Yes		
			Volume	Yes		
			Brightness	Yes		
			Contrast	Yes		
			Color	Yes		
			Tint	Yes		
Sharpness	Yes					
Tuning		No				
Bass	Yes					
Treble	Yes					
Balance	Yes					
Back Light		No				
Stereo,Audio Output,SAP	Yes					
Video	Yes					
Color Stream	Yes					
Channel(TV/Cable)	Yes					
CH Label	Yes					
Game Timer	Yes					
Sleep Timer	Yes					
Sound Mute	Yes					
V-chip Rating		No				
16: 9		No				
G-8	OSD Language		English	French	Spanish	
G-9	Clock and Timer	Sleep Timer	Max Time	120 Min		
			Step	<u> </u> 10 <u> </u> Min		
		On/Off Timer	Program(On Timer / Off Timer / Clock)	Yes		
		Wake Up Timer			No	
	Timer Back-up (at Power Off Mode)	more than	--	Min	Sec	

GENERAL SPECIFICATIONS

G-10	Remote Control	Unit	RC-GQ		
		Glow in Dark Remocon	Yes		
		Format	Toshiba		
		Remocon Format	Toshiba		
		Custom Code	TV:40-BF h		
		Power Source	Voltage(D.C) UM size x pcs	3V UM-4 x 2 pcs	
		Total Keys		29	
		Keys	Power	Yes	
			1	Yes	
			2	Yes	
			3	Yes	
			4	Yes	
			5	Yes	
			6	Yes	
			7	Yes	
			8	Yes	
			9	Yes	
			0	Yes	
			100	Yes	
			CH Up	Yes	
			CH Down	Yes	
			Volume Up	Yes	
			Volume Down	Yes	
			TV/Caption/Text	Yes	
			CH1/CH2	Yes	
			TV/Video(TV/AV)	Yes	
			CH RTN/CH ENT(Quick View)	Yes	
			Sleep	Yes	
			RE Call(Call)	Yes	
			Reset	Yes	
			Menu/Enter	Yes	
			Mute	Yes	
			Exit	Yes	
			MTS(Audio Select)	Yes	
			Fav.Up	Yes	
			Fav.Down	Yes	
			16: 9	No	
			Multi Brand Keys	CH Up(VCR)	No
				CH Down(VCR)	No
				Pause/Still	No
		TV/VCR(VCR)		No	
		FF		No	
		Rew		No	
		Rec		No	
		Play		No	
		Stop		No	
		TV		No	
		VCR		No	
		Cable		No	
		DVD		No	
		CODE		No	
		Volume Up(DVD)		No	
Volume Down(DVD)	No				
DVD CLEAR	No				
TOP MENU	No				
DVD MENU	No				
DISPLAY	No				

GENERAL SPECIFICATIONS

G-11	Features	Auto Degauss	Yes
		Auto Shut Off	Yes
		Canal+	No
		CATV	Yes
		Anti-theft	No
		Rental	No
		Memory(Last CH)	Yes
		Memory(Last Volume)	Yes
		V-Chip	No
		Type	- Type
		BBE	No
		Auto Search	No
		CH Allocation	No
		SAP	Yes
		Just Clock Function	No
		CH Label	Yes
		VM Circuit	No
		Full OSD	No
		Premiere	No
		Comb Filter	Yes 2 Lines
		Auto CH Memory	Yes
		Hotel Lock	No
		Closed Caption	Yes
		Stable Sound	Yes
		FBT Leak Test Protect	Yes
		CH Lock	Yes
		Video Lock	Yes
		Game Timer (Max Time:120 Min)	Yes
		Energy Star	No
		Favorite CH	Yes
		Surround	Yes
		16:9 Mode	No
2 Tuner P-in-P	No		
G-12	Accessories	Owner's Manual	English /French
		Language W/ Warranty	Yes
		Remote Control Unit	Yes
		Rod Antenna	No
		Poles	
		Terminal	
		Loop Antenna	No
		Terminal	
		U/V Mixer	No
		DC Car Cord (Center+)	No
		Guarantee Card	No
		Warning Sheet	No
		Circuit Diagram	No
		Antenna Change Plug	No
		Service Facility List	No
		Important Safety Instruction	No
		Dew/AHC Caution Sheet	No
		AC Plug Adapter	No
		Quick Set-up Sheet	No
		Battery	Yes UM size x pcs UM4 size x 2
		OEM Brand	No
		AC Cord	No
AV Cord (2Pin-1Pin)	No		
Registration Card (NDL Card)	No		
ESP Card	No		
PTB Sheet	No		
300 ohm to 75 ohm Antenna Adapter	No		

GENERAL SPECIFICATIONS

G-13	Interface	Switch	Front	Power	Yes
				System Select	No
				Main Power SW	No
				Sub Power	No
				Channel Up	Yes
				Channel Down	Yes
				Volume Up	Yes
		Rear	Volume Down	Yes	
			AC/DC	No	
			TV/CATV Selector	No	
			Degauss	No	
		Indicator	Main Power SW	No	
			Power	Yes(RED)	
			Stand-by On Timer	No No	
		Terminals	Front	Video Input	RCA
				Audio Input	RCA x 2
				Other Terminal	No
			Rear	Video Input(Rear1)	RCA
				Video Input(Rear2)	No
				Audio Input(Rear1)	RCA x 2
				Audio Input(Rear2)	No
				Video Output	No
				Audio Output	No
S- Input	Yes				
Euro Scart	No				
Color Stream	RCA x 3				
Diversity	No				
Ext Speaker	No				
DC Jack 12V(Center +)	No				
VHF/UHF Antenna Input	F Type				
AC Outlet	No				
G-14	Set Size	Approx. W x D x H (mm)		650 x 500.5 x 571.5	
G-15	Weight	Net (Approx.)		36.5kg (80.5 lbs)	
		Gross (Approx.)		40.5Kg (89.3 lbs)	
G-16	Carton	Master Carton	Content	No	
			Material	--- Sets	
			Dimensions W x D x H(mm)	-- /--	
			Description of Origin	No	
		Gift Box	Material	Double/Brown	
			Dimensions W x D x H(mm)	771 x 580 x 665	
			Design	As per Buyer's	
		Drop Test	Description of Origin	Yes	
			Height (cm)	Natural Dropping At 1 Corner / 2 Edges / 4 Surfaces	
			Container Stuffing	60 (ORION SPEC:31)	
G-17	Cabinet Material	Cabinet	Cabinet Front	PS 94V0 DECABROM	
			Cabinet Rear	PS 94V0 DECABROM	
		PCB	Non-Halogen Demand	No	
			Eyelet Demand	Yes	
G-18	Environment	Pb-free Soldering		Yes	
		Parts Specificat		Yes	

DISASSEMBLY INSTRUCTIONS

1. REMOVAL OF ANODE CAP

Read the following **NOTED** items before starting work.

- * After turning the power off there might still be a potential voltage that is very dangerous. When removing the Anode Cap, make sure to discharge the Anode Cap's potential voltage.
- * Do not use pliers to loosen or tighten the Anode Cap terminal, this may cause the spring to be damaged.

REMOVAL

1. Follow the steps as follows to discharge the Anode Cap. (Refer to Fig. 1-1.)

Connect one end of an Alligator Clip to the metal part of a flat-blade screwdriver and the other end to ground. While holding the plastic part of the insulated Screwdriver, touch the support of the Anode with the tip of the Screwdriver. A cracking noise will be heard as the voltage is discharged.

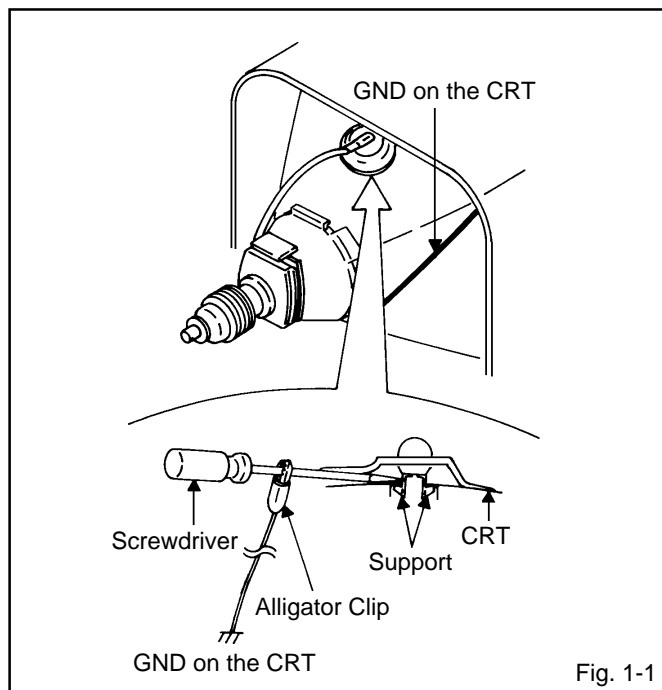

2. Flip up the sides of the Rubber Cap in the direction of the arrow and remove one side of the support. (Refer to Fig. 1-2.)

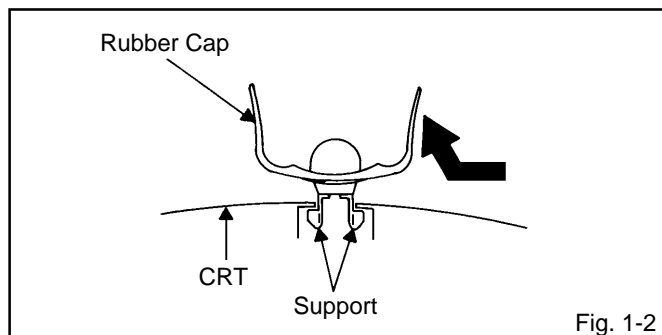

3. After one side is removed, pull in the opposite direction to remove the other.

NOTE

Take care not to damage the Rubber Cap.

INSTALLATION

1. Clean the spot where the cap was located with a small amount of alcohol. (Refer to Fig. 1-3.)

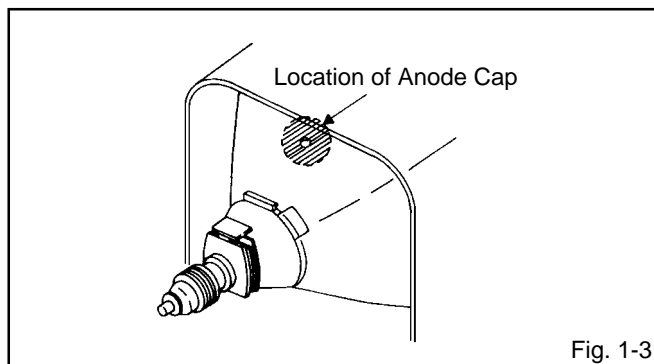

NOTE

Confirm that there is no dirt, dust, etc. at the spot where the cap was located.

2. Arrange the wire of the Anode Cap and make sure the wire is not twisted.
3. Turn over the Rubber Cap. (Refer to Fig. 1-4.)

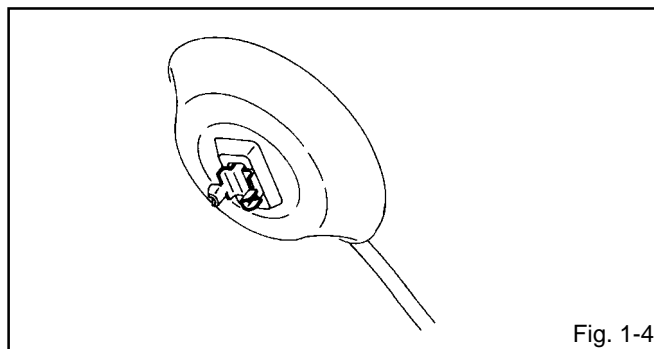

4. Insert one end of the Anode Support into the anode button, then the other as shown in Fig. 1-5.

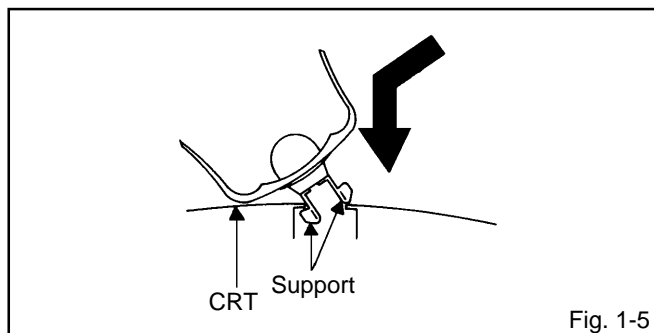

5. Confirm that the Support is securely connected.
6. Put on the Rubber Cap without moving any parts.

DISASSEMBLY INSTRUCTIONS

2. REMOVAL AND INSTALLATION OF FLAT PACKAGE IC

REMOVAL

1. Put the Masking Tape (cotton tape) around the Flat Package IC to protect other parts from any damage. (Refer to Fig. 2-1.)

NOTE

Masking is carried out on all the parts located within 10 mm distance from IC leads.

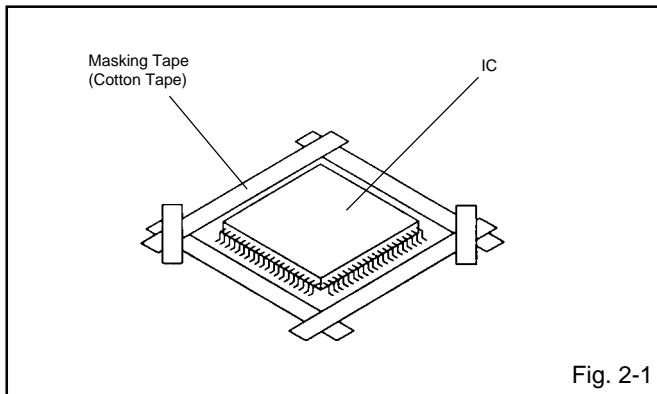

2. Heat the IC leads using a blower type IC desoldering machine. (Refer to Fig. 2-2.)

NOTE

Do not add the rotating and the back and forth directions force on the IC, until IC can move back and forth easily after desoldering the IC leads completely.

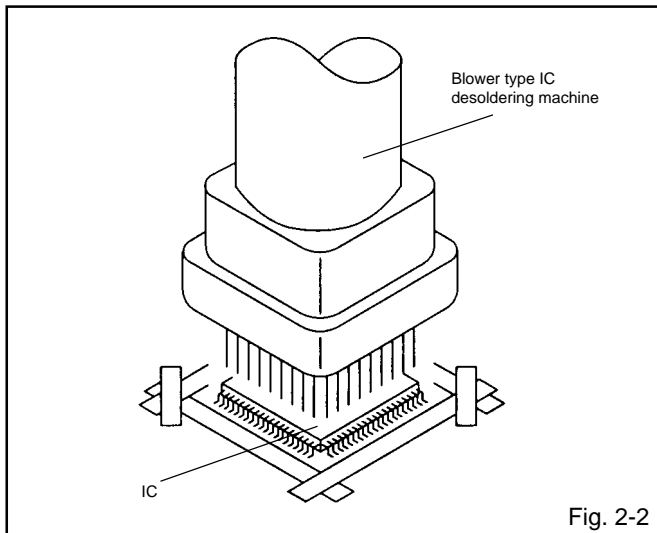

3. When IC starts moving back and forth easily after desoldering completely, pickup the corner of the IC using a tweezers and remove the IC by moving with the IC desoldering machine. (Refer to Fig. 2-3.)

NOTE

Some ICs on the PCB are affixed with glue, so be careful not to break or damage the foil of each IC leads or solder lands under the IC when removing it.

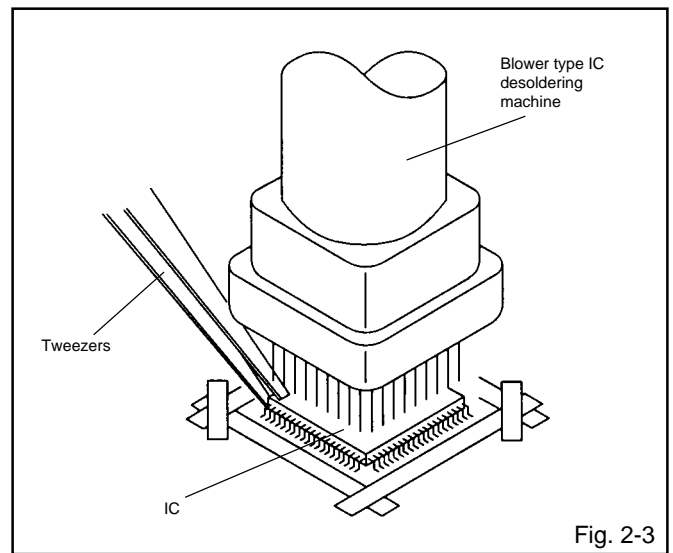

4. Peel off the Masking Tape.

5. Absorb the solder left on the pattern using the Braided Shield Wire. (Refer to Fig. 2-4.)

NOTE

Do not move the Braided Shield Wire in the vertical direction towards the IC pattern.

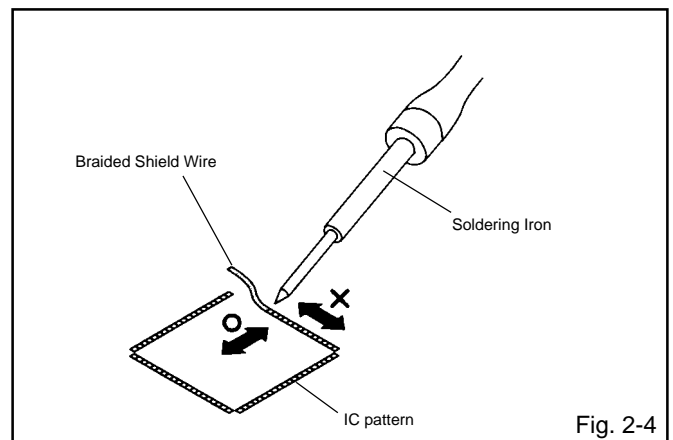

DISASSEMBLY INSTRUCTIONS

INSTALLATION

1. Take care of the polarity of new IC and then install the new IC fitting on the printed circuit pattern. Then solder each lead on the diagonal positions of IC temporarily. (Refer to Fig. 2-5.)

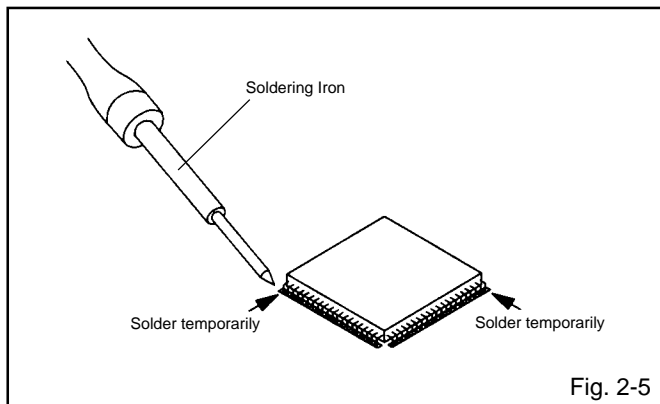

2. Supply the solder from the upper position of IC leads sliding to the lower position of the IC leads. (Refer to Fig. 2-6.)

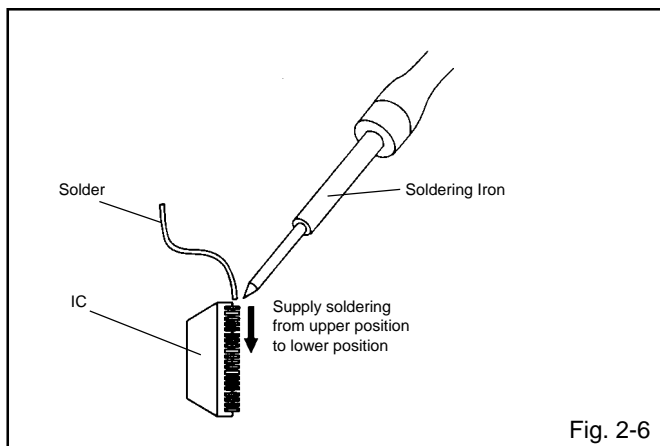

3. Absorb the solder left on the lead using the Braided Shield Wire. (Refer to Fig. 2-7.)

NOTE

Do not absorb the solder to excess.

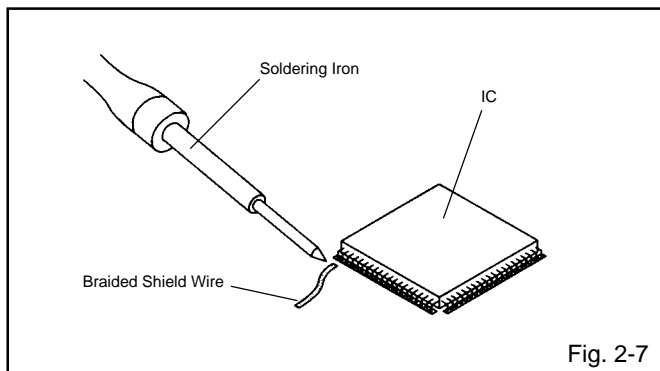

4. When bridge-soldering between terminals and/or the soldering amount are not enough, resolder using a Thin-tip Soldering Iron. (Refer to Fig. 2-8.)

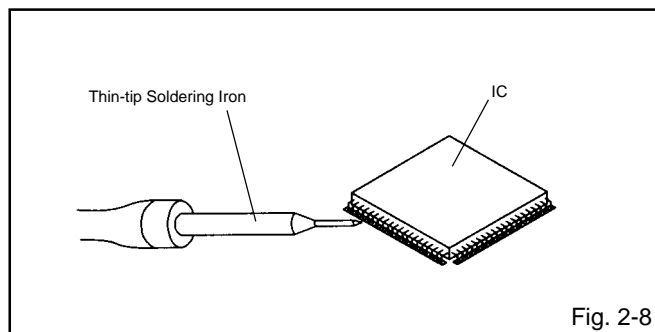

5. Finally, confirm the soldering status on four sides of the IC using a magnifying glass. Confirm that no abnormality is found on the soldering position and installation position of the parts around the IC. If some abnormality is found, correct by resoldering.

NOTE

When the IC leads are bent during soldering and/or repairing, do not repair the bending of leads. If the bending of leads are repaired, the pattern may be damaged. So, always be sure to replace the IC in this case.

SERVICE MODE LIST

This unit is provided with the following SERVICE MODES so you can repair, examine and adjust easily. To enter the Service Mode, press both set key and remote control key for more than 1 second.

Set Key	Remocon Key	Operations
VOL. (-) MIN	0	Releasing of V-CHIP PASSWORD.
VOL. (-) MIN	1	Initialization of factory data. NOTE: Do not use this for normal servicing. If you set factory initialization, the memories are reset such as the channel setting, and the POWER ON total hours.
VOL. (-) MIN	6	POWER ON total hours is displayed on the screen. Refer to the "CONFIRMATION OF HOURS USED". Can be checked of the INITIAL DATA of MEMORY IC. Refer to the "WHEN REPLACING EEPROM (MEMORY) IC".
VOL. (-) MIN	8	Writing of EEPROM initial data. NOTE: Do not use this for the normal servicing.
VOL. (-) MIN	9	Display of the Adjustment MENU on the screen. Refer to the "ELECTRICAL ADJUSTMENT" (On-Screen Display Adjustment).

CONFIRMATION OF HOURS USED

POWER ON total hours can be checked on the screen. Total hours are displayed in 16 system of notation.

NOTE: If you set factory initialization, the total hours is reset to "0".

1. Set the VOLUME to minimum.
2. Press both VOL. DOWN button on the set and Channel button (6) on the remote control for more than 1 second.
3. After the confirmation of using hours, turn off the power.

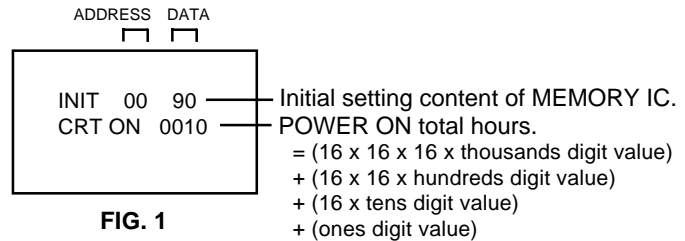

FIG. 1

WHEN REPLACING EEPROM (MEMORY) IC

If a service repair is undertaken where it has been required to change the MEMORY IC, the following steps should be taken to ensure correct data settings while making reference to TABLE 1.

INI	+0	+1	+2	+3	+4	+5	+6	+7	+8	+9	+A	+B	+C	+D	+E	+F
00	90	E8	03	25	5E	B3	24	35	38	AC	0B	04	40	40	40	7F
10	50	00	00	00	01	00	00	99	3F	0F	0D	E6	A8	21	46	00

Table 1

1. Enter DATA SET mode by setting VOLUME to minimum.
 2. Press both VOL. DOWN button on the set and Channel button (6) on the remote control for more than 1 second. ADDRESS and DATA should appear as FIG 1.
 3. ADDRESS is now selected and should "blink". Using the VOL. UP/DOWN button on the remote, step through the ADDRESS until required ADDRESS to be changed is reached.
 4. Press ENTER to select DATA. When DATA is selected, it will "blink".
 5. Again, step through the DATA using VOL. UP/DOWN button until required DATA value has been selected.
 6. Pressing ENTER will take you back to ADDRESS for further selection if necessary.
 7. Repeat steps 3 to 6 until all data has been checked.
 8. When satisfied correct DATA has been entered, turn POWER off (return to STANDBY MODE) to finish DATA input.
After the data input, set to the initializing of shipping.
 9. Turn POWER on.
 10. Press both VOL. DOWN button on the set and Channel button (1) on the remote control for more than 1 second.
 11. After the finishing of the initializing of shipping, the unit will turn off automatically.
- The unit will now have the correct DATA for the new MEMORY IC.

ELECTRICAL ADJUSTMENTS

1. ADJUSTMENT PROCEDURE

Read and perform these adjustments when repairing the circuits or replacing electrical parts or PCB assemblies.

CAUTION

- Use an isolation transformer when performing any service on this chassis.
- Before removing the anode cap, discharge electricity because it contains high voltage.
- When removing a PCB or related component, after unfastening or changing a wire, be sure to put the wire back in its original position.
- When you exchange IC and Transistor with a heat sink, apply silicon grease on the contact section of the heat sink. Before applying new silicon grease, remove all the old silicon grease. (Old grease may cause damages to the IC and Transistor.)

Prepare the following measurement tools for electrical adjustments.

1. Oscilloscope
2. Digital Voltmeter
3. Multi-sound Generator
4. Pattern Generator

On-Screen Display Adjustment

1. In the condition of NO indication on the screen. Press the VOL. DOWN button on the set and the Channel button (9) on the remote control for more than 1 second to appear the adjustment mode on the screen as shown in Fig. 1-1.

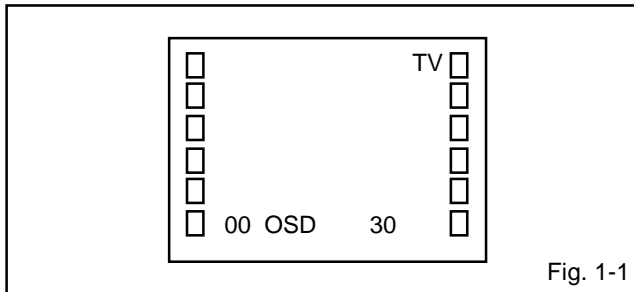

Fig. 1-1

2. Use the Channel UP/DOWN button or Channel button (0-9) on the remote control to select the options shown in Fig. 1-2.
3. Press the MENU button on the remote control to end the adjustments.

NO.	FUNCTION	NO.	FUNCTION
00	OSD H	18	CONTRAST MAX
01	CUT OFF	19	CONTRAST CENT
02	H. VCO	20	CONTRAST MIN
03	H. PHASE	21	COLOR MAX
04	AFC GAIN	22	COLOR CENTER
05	V. SHIFT	23	COLOR MIN
06	H. SIZE	24	TINT
07	V. SIZE	25	SHARPNESS
08	V. LINERITY	26	CB DL
09	VS CORRECTION	27	CR DL
10	R DRIVE	28	CB PED
11	B DRIVE	29	CR PED
12	R CUT OFF	30	PARABOLA
13	G CUT OFF	31	CORNER
14	B CUT OFF	32	TRAPWZIUM
15	BRIGHT MAX	33	LEVEL
16	BRIGHT CENT	34	SEPARATION1
17	BRIGHT MIN	35	SEPARATION2

Fig. 1-2

2. BASIC ADJUSTMENTS

2-1: CONSTANT VOLTAGE

1. Place the set in AV MODE without signal.
2. Connect the digital voltmeter to the TP003.
3. Adjust the VR502 until the digital voltmeter is $120 \pm 0.5V$.

2-2: CUT OFF

1. Place the set in Aging Test for more than 15 minutes.
2. Place the set in AV MODE without signal.
3. Using the remote control, set the brightness and contrast to normal position.
4. Activate the adjustment mode display of Fig. 1-1 and press the channel button (01) on the remote control to select "CUT OFF".
5. Adjust the Screen Volume until a dim raster is obtained.

2-3: WHITE BALANCE, WHITE BALANCE CS

NOTE: Adjust after performing CUT OFF adjustment.

1. Place the set in Aging Test for more than 15 minutes.
2. Receive the gray scale pattern from the Pattern Generator with Burst on.
3. Using the remote control, set the brightness and contrast to normal position.
4. Activate the adjustment mode display of Fig. 1-1 and press the channel button (12) on the remote control to select "R. BIAS".
5. Press the CH. UP/DOWN button on the remote control to select the "R. BIAS", "G. BIAS", "B. BIAS", "B. DRIVE" or "R. DRIVE".
6. Adjust the VOL. UP/DOWN button on the remote control to whiten the R. BIAS, G. BIAS, B. BIAS, B. DRIVE and R. DRIVE at each step tone sections equally.
7. Perform the above adjustments 5 and 6 until the white color is achieved.
8. Press the TV/VIDEO button on the remote control to set to the CS mode.
9. Receive the gray scale pattern from the Pattern Generator with Burst On.
10. If the picture is too much green. Activate the adjustment mode display of Fig. 1-1 and press the channel button (28) on the remote control to select "CB PED".
11. Adjust the VOL. UP/DOWN button on the remote control to select the step up.
12. If the picture is too much red. Activate the adjustment mode display of Fig. 1-1 and press the channel button (29) on the remote control to select "CR PED".
13. Adjust the VOL. UP/DOWN button on the remote control to select the step down.

ELECTRICAL ADJUSTMENTS

2-4: COLOR CENT

1. Receive the color bar pattern. (RF Input)
2. Using the remote control, set the brightness, contrast, color and tint to normal position.
3. Connect the oscilloscope to **TP022**.
4. Activate the adjustment mode display of **Fig. 1-1** and press the channel button (**22**) on the remote control to select "COLOR CENT".
5. Adjust the VOLTS RANGE VARIABLE knob of the oscilloscope until the range between white 100% and 0% is set to 4 scales on the screen of the oscilloscope.
6. Press the VOL. UP/DOWN button on the remote control until the red color level is adjusted to $120 \pm 10\%$ of the white level. (**Refer to Fig. 2-1**)
7. Receive the video color bar pattern. (Audio Video Input)
8. Set to the AV mode. Then perform the above adjustments 2~6.
9. Press the TV/VIDEO button on the remote control to set to the CS mode. Then perform the above adjustments 2~4.
10. Press the VOL. UP/DOWN button on the remote control until the color step No. becomes "70".

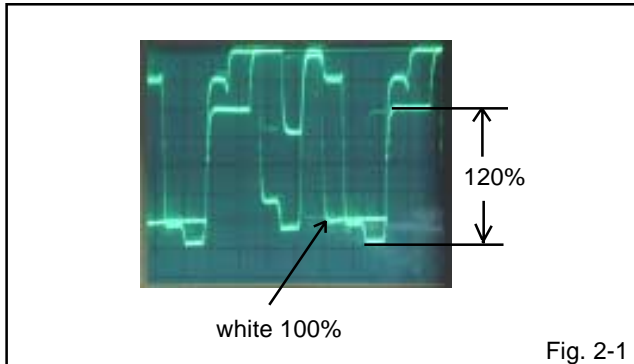

2-5: TINT

1. Receive the color bar pattern. (RF Input)
2. Using the remote control, set the brightness, contrast, color and tint to normal position.
3. Connect the oscilloscope to **TP024**.
4. Activate the adjustment mode display of **Fig. 1-1** and press the channel button (**24**) on the remote control to select "TINT".
5. Press the VOL. UP/DOWN button on the remote control until the section "A" becomes as straight line. (**Refer to Fig. 2-2**)
6. Receive the video color bar pattern. (Audio Video Input)
7. Set to the AV mode. Then perform the above adjustments 2~5.
8. Press the TV/VIDEO button on the remote control to set to the CS mode. Then perform the above adjustments 2~4.
9. Press the VOL. UP/DOWN button on the remote control until the tint step No. becomes "53".

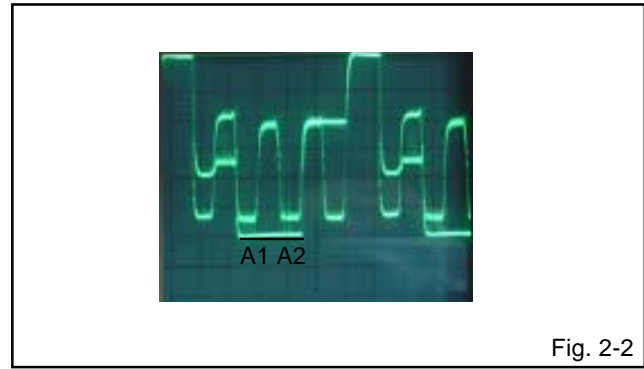

2-6: FOCUS

1. Receive the monoscope pattern.
2. Turn the Focus Volume fully counterclockwise once.
3. Adjust the Focus Volume until picture is distinct.

2-7: VERTICAL SIZE

1. Receive the monoscope pattern.
2. Using the remote control, set the brightness and contrast to normal position.
3. Activate the adjustment mode display of **Fig. 1-1** and press the channel button (**07**) on the remote control to select "V. SIZE".
4. Press the VOL. UP/DOWN button on the remote control until the SHIFT quantity of the OVER SCAN on upside and downside becomes $9 \pm 3\%$.

2-8: VERTICAL POSITION

1. Receive the monoscope pattern.
2. Using the remote control, set the brightness and contrast to normal position.
3. Adjust the **VR401** until the horizontal line becomes fit to the notch of the shadow mask. (**Refer to Fig. 2-3**)

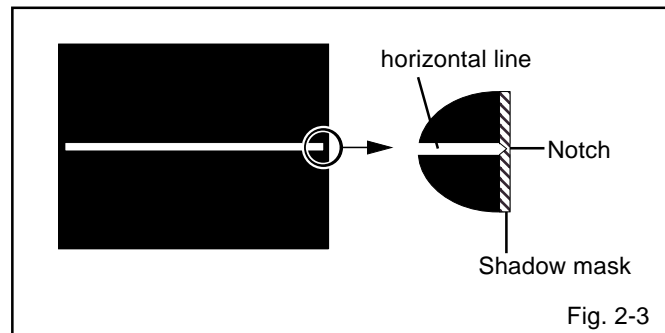

2-9: VERTICAL LINEARITY

NOTE: Adjust after performing adjustments in section 2-8. After the adjustment of Vertical Linearity, reconfirm the Vertical Position and Vertical Size adjustments.

1. Receive the monoscope pattern.
2. Using the remote control, set the brightness, contrast, to normal position.
3. Activate the adjustment mode display of **Fig. 1-1** and press the channel button (**08**) on the remote control to select "V. LINEARITY".
4. Press the VOL. UP/DOWN button on the remote control until the SHIFT quantity of the OVER SCAN on upside and downside becomes minimum.

ELECTRICAL ADJUSTMENTS

2-10: HORIZONTAL POSITION

1. Receive the monoscope pattern.
2. Activate the adjustment mode display of **Fig. 1-1** and press the channel button **(03)** on the remote control to select "H.PHASE".
3. Press the VOL. UP/DOWN button on the remote control until the SHIFT quantity of the OVER SCAN on right and left becomes minimum.

2-11: HORIZONTAL SIZE

1. Receive the monoscope pattern.
2. Using the remote control, set the brightness and contrast to normal position.
3. Activate the adjustment mode display of **Fig. 1-1** and press the channel button **(06)** on the remote control to select "H. SIZE".
4. Press the VOL. UP/DOWN button on the remote control adjust the H.SIZE becomes 10 ~ 12%.

2-12: OSD POSITION

1. Activate the adjustment mode display of **Fig. 1-1**.
2. Press the VOL. UP/DOWN button on the remote control until the difference of A and B becomes minimum. (**Refer to Fig. 2-4**)

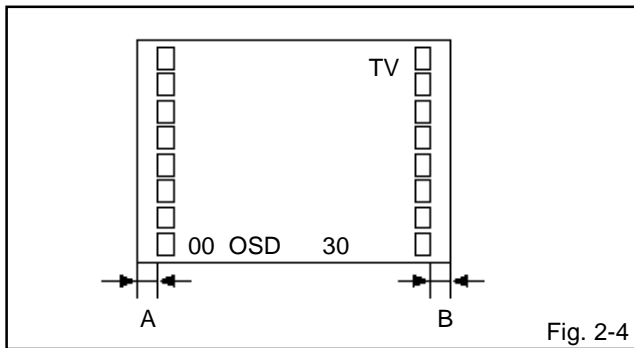

2-13: BRIGHT CENT

1. Receive the monoscope pattern. (RF Input)
2. Using the remote control, set the brightness and contrast to normal position.
3. Activate the adjustment mode display of **Fig. 1-1** and press the channel button **(16)** on the remote control to select "BRI CENT".
4. Press the VOL. UP/DOWN button on the remote control until the screen begin to shine.
5. Receive the monoscope pattern. (Audio Video Input)
6. Press the TV/VIDEO button on the remote control to set to the AV mode. Then perform the above adjustments 2~4.
7. Press the TV/VIDEO button on the remote control to set to the CS mode.
8. Activate the adjustment mode display of **Fig. 1-1** and press the channel button **(16)** on the remote control to select "BRI CENT".
9. Press the VOL. UP/DOWN button on the remote control until the brightness step No. becomes "90".

2-14: CONTRAST MAX

1. Activate the adjustment mode display of **Fig. 1-1** and press the channel button **(18)** on the remote control to select "CONT. MAX".
2. Press the VOL. UP/DOWN button on the remote control until the contrast step No. becomes "90".
3. Receive a broadcast and check if the picture is normal.
4. Press the TV/VIDEO button on the remote control to set to the AV mode. Then perform the above adjustments 1~3.
5. Press the TV/VIDEO button on the remote control to set to the CS mode. Then perform the above adjustments 1~3.

2-15: PARABOLA/CORNER

1. Receive the cross hatch signal from the Pattern Generator.
2. Using the remote control, set the brightness and contrast to normal position.
3. Activate the adjustment mode display of **Fig. 1-1** and press the channel button **(30)** on the remote control to select "PARABOLA".
4. Press the VOL. UP/DOWN button on the remote control until the right and left vertical lines are straight.
5. In the case the right and left vertical lines are not straight.
6. Please Activate the adjustment mode display of **Fig. 1-1** and press the channel button **(31)** on the remote control to select "CORNER".
7. Press the VOL. UP/DOWN button on the remote control until the right and left vertical lines are straight.

2-16: TRAPEZIUM

1. Receive the cross hatch signal from the Pattern Generator.
2. Using the remote control, set the brightness and contrast to normal position.
3. Activate the adjustment mode display of **Fig. 1-1** and press the channel button **(32)** on the remote control to select "TRAPEZIUM".
4. Press the VOL. UP/DOWN button on the remote control until the both vertical lines of the screen become parallel.

2-17: SEPARATION 1, 2

1. Receive the stereo signal (L=2KHz, R=400Hz).
2. Connect the AC voltmeter to **Audio Out Jack** though stereo filter (L=400Hz, R=2KHz).
3. Activate the adjustment mode display of **Fig. 1-1** and press the channel button **(34)** on the remote control to select "SEP1".
4. Press the VOL. UP/DOWN button on the remote control until the output of L-CH and R-CH become minimum.
5. Press the CH UP button once the set to "SEP2 mode.
6. Press the VOL. UP/DOWN button on the remote control until the output of L-CH and R-CH become minimum.
7. Press the CH DOWN button once the set to "SEP1" mode.
8. Repeat step 4 to step 7 several times.
The output difference of the between with Filter and without Filter should be more than 25db for both L and R.

ELECTRICAL ADJUSTMENTS

2-18: LEVEL

1. Connect the AC voltmeter to **pin 6 of CP101**.
2. Activate the adjustment mode display of **Fig. 1-1** and press the channel button (**33**) on the remote control to select "LEVEL".
3. Press the VOL. UP/DOWN button on the remote control until the AC voltmeter is $85 \pm 2\text{mV}$.

2-19: Confirmation of Fixed Value (Step No.)

Please check if the fixed values of the each adjustment items are set correctly referring below.

NO.	FUNCTION	RF	AV	CS
02	H.VCO	04	04	04
04	AFC GAIN	04	04	04
05	V.SHIFT	02	02	02
09	VS CORRECTION	42	42	42
15	BRI.MAX	140	140	140
17	BRI.MIN	50	50	50
19	CONT.CENT	64	64	64
20	CONT.MIN	20	20	20
21	COL.MAX	90	90	90
23	COL.MIN	00	00	00
25	SHARPNESS	40	40	40
26	CB DL	00	00	00
27	CR DL	00	00	00

ELECTRICAL ADJUSTMENTS

3. PURITY AND CONVERGENCE ADJUSTMENTS

NOTE

1. Turn the unit on and let it warm up for at least 30 minutes before performing the following adjustments.
2. Place the CRT surface facing east or west to reduce the terrestrial magnetism.
3. Turn ON the unit and demagnetize with a Degauss Coil.

3-1: STATIC CONVERGENCE (ROUGH ADJUSTMENT)

1. Tighten the screw for the magnet. Refer to the adjusted CRT for the position. **(Refer to Fig. 3-1)**
If the deflection yoke and magnet are in one body, untighten the screw for the body.
2. Receive the green raster pattern from the color bar generator.
3. Slide the deflection yoke until it touches the funnel side of the CRT.
4. Adjust center of screen to green, with red and blue on the sides, using the pair of purity magnets.
5. Switch the color bar generator from the green raster pattern to the crosshatch pattern.
6. Combine red and blue of the 3 color crosshatch pattern on the center of the screen by adjusting the pair of 4 pole magnets.
7. Combine red/blue (magenta) and green by adjusting the pair of 6 pole magnets.
8. Adjust the crosshatch pattern to change to white by repeating steps 6 and 7.

3-2: PURITY

NOTE

Adjust after performing adjustments in section 3-1.

1. Receive the green raster pattern from color bar generator.
2. Adjust the pair of purity magnets to center the color on the screen.
Adjust the pair of purity magnets so the color at the ends are equally wide.
3. Move the deflection yoke backward (to neck side) slowly, and stop it at the position when the whole screen is green.
4. Confirm red and blue color.
5. Adjust the slant of the deflection yoke while watching the screen, then tighten the fixing screw.

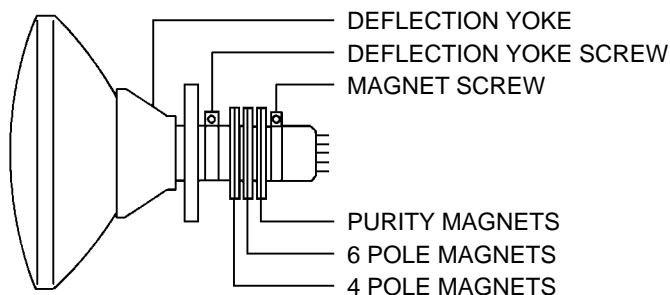

Fig. 3-1

3-3: STATIC CONVERGENCE

NOTE

Adjust after performing adjustments in section 3-2.

1. Receive the crosshatch pattern from the color bar generator.
2. Combine red and blue of the 3 color crosshatch pattern on the center of the screen by adjusting the pair of 4 pole magnets.
3. Combine red/blue (magenta) and green by adjusting the pair of 6 pole magnets.

3-4: DYNAMIC CONVERGENCE

NOTE

Adjust after performing adjustments in section 3-3.

1. Adjust the differences around the screen by moving the deflection yoke upward/downward and right/left. **(Refer to Fig. 3-2-a)**
2. Insert three wedges between the deflection yoke and CRT funnel to fix the deflection yoke. **(Refer to Fig. 3-2-b)**

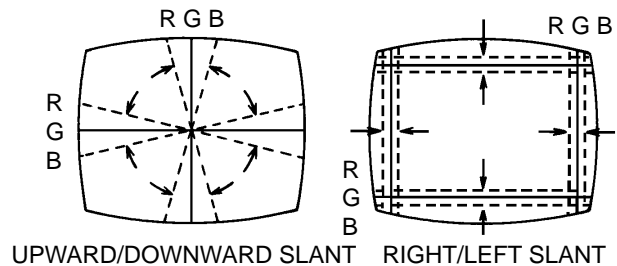

Fig. 3-2-a

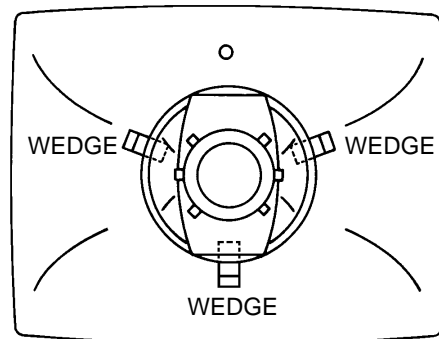
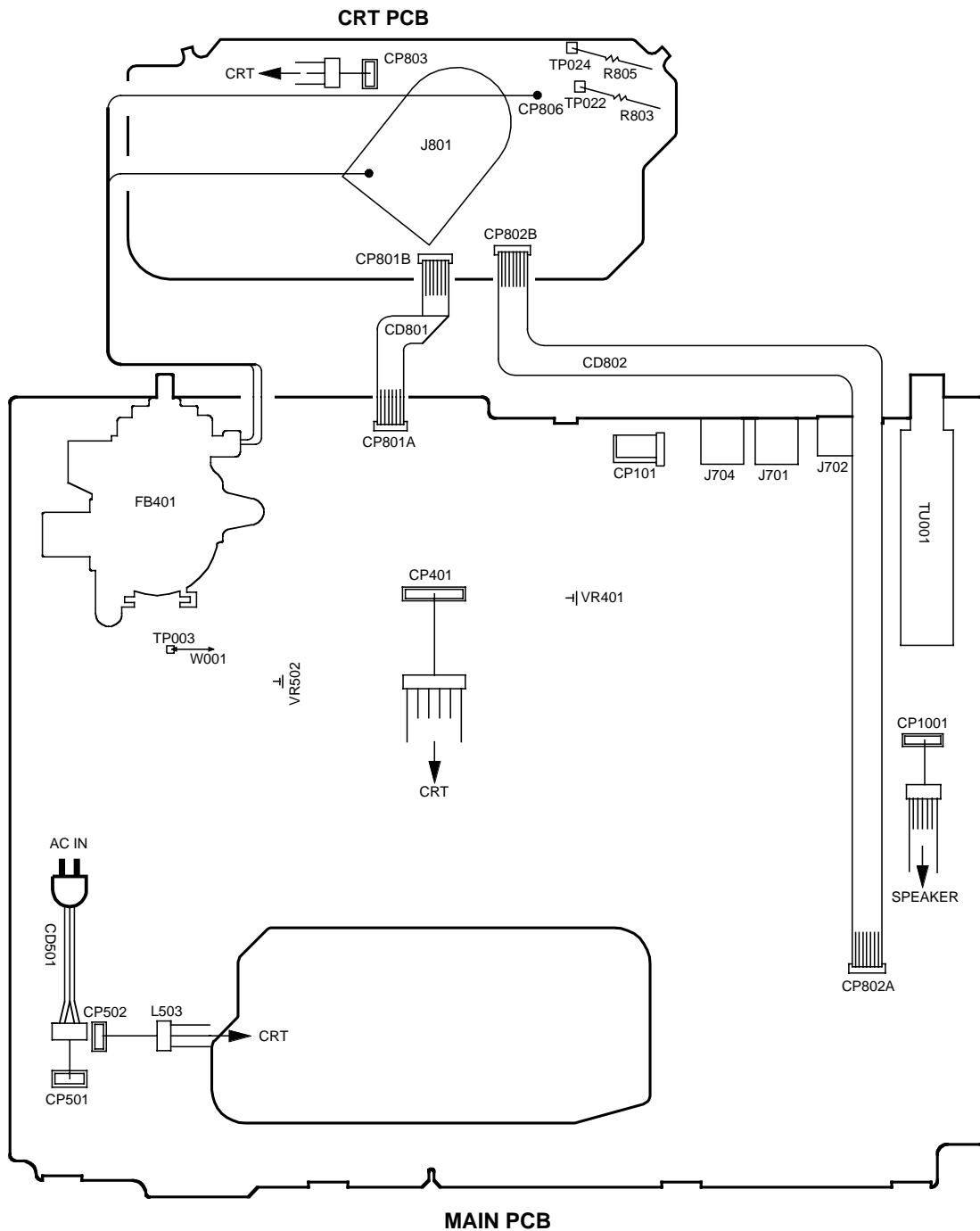

Fig. 3-2-b

ELECTRICAL ADJUSTMENTS

4. ELECTRICAL ADJUSTMENT PARTS LOCATION GUIDE (WIRING CONNECTION)



BLOCK DIAGRAM

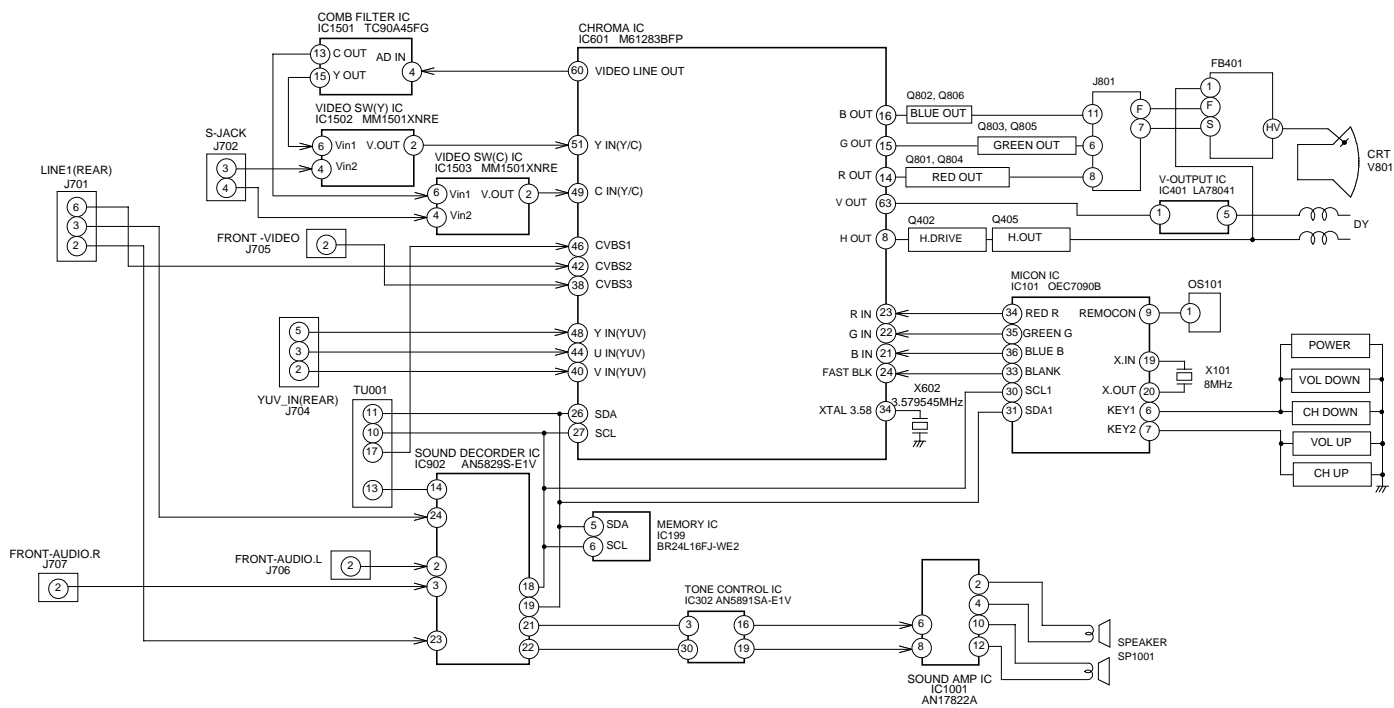

PRINTED CIRCUIT BOARDS
MAIN/CRT (INSERTED PARTS)
SOLDER SIDE

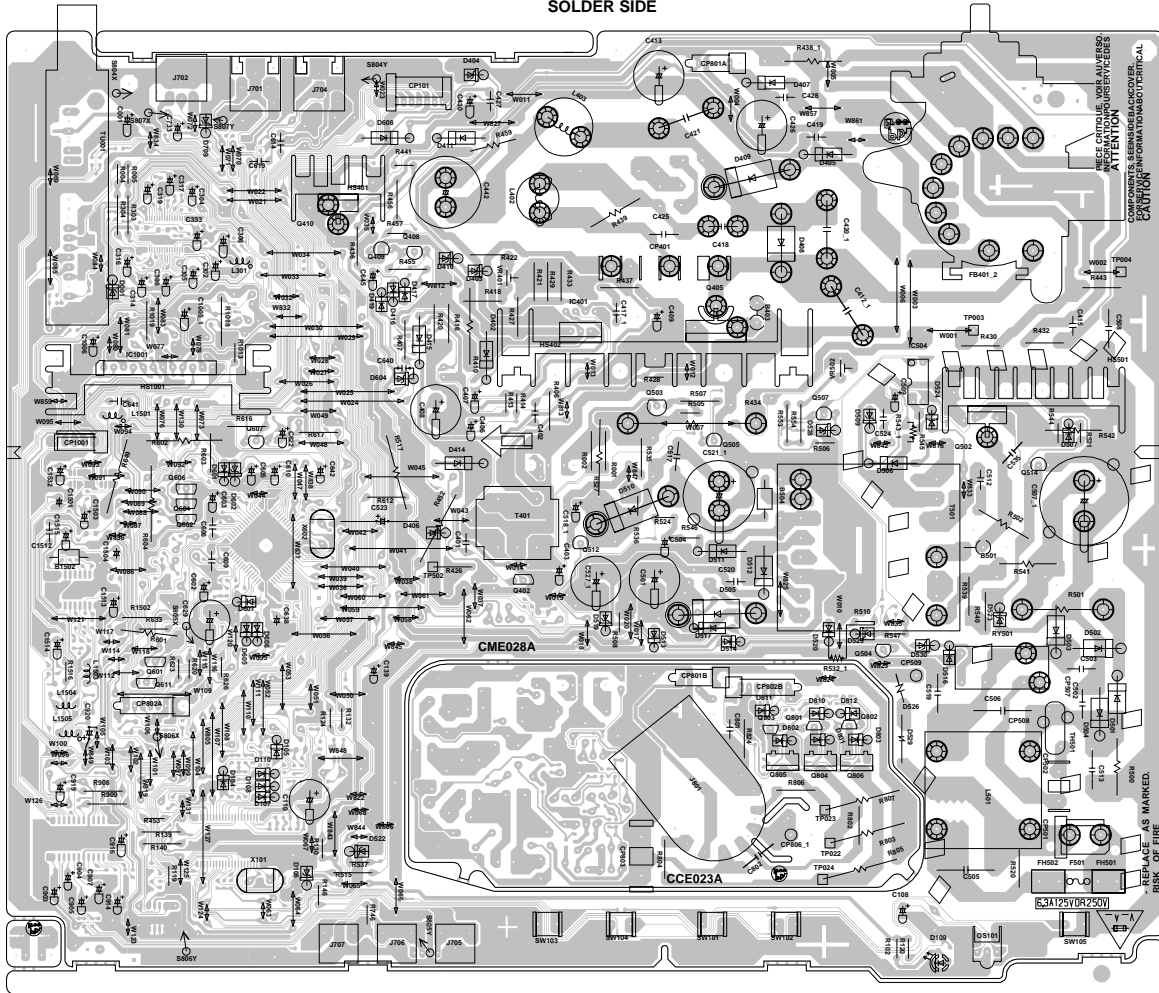

PRINTED CIRCUIT BOARDS
MAIN/CRT (CHIP MOUNTED PARTS)
SOLDER SIDE

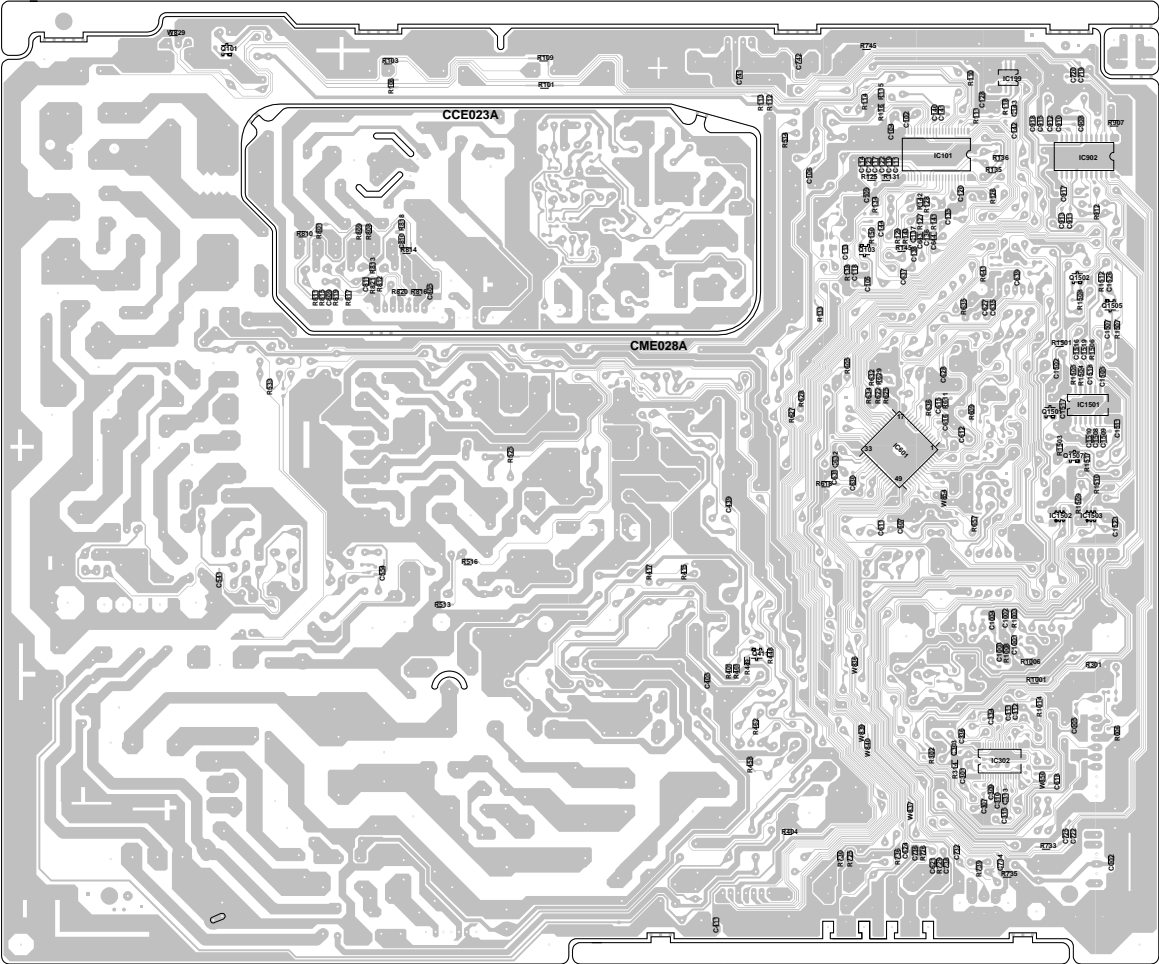

MICON SCHEMATIC DIAGRAM (MAIN PCB)

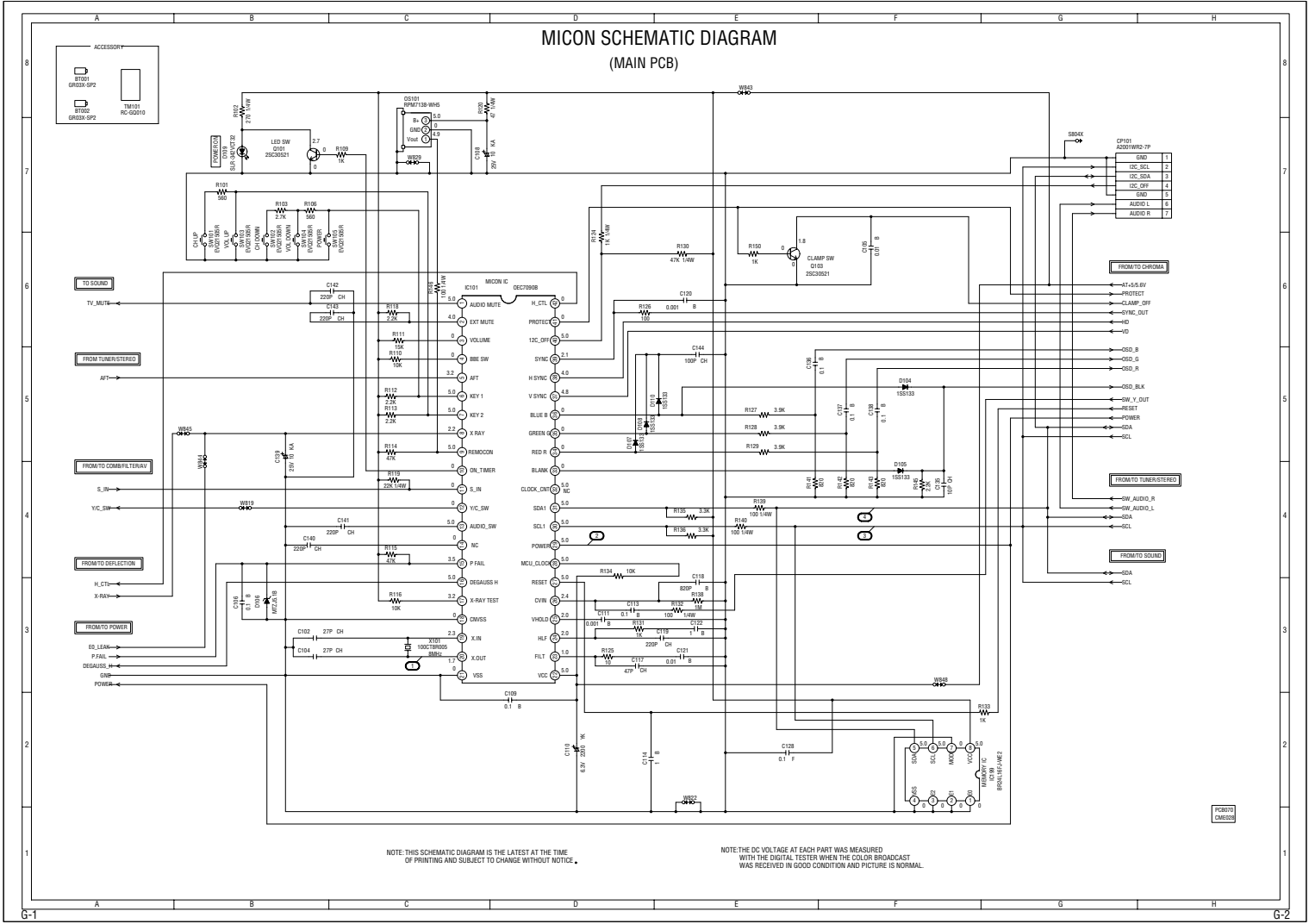

NOTE: THIS SCHEMATIC DIAGRAM IS THE LATEST AT THE TIME OF PRINTING AND SUBJECT TO CHANGE WITHOUT NOTICE.

NOTE: THE DC VOLTAGE AT EACH PART WAS MEASURED WITH THE DIGITAL TESTER WHEN THE COLOR BROADCAST WAS RECEIVED IN GOOD CONDITION AND PICTURE IS NORMAL.

FIG.010
CM/002

CHROMA SCHEMATIC DIAGRAM (MAIN PCB)

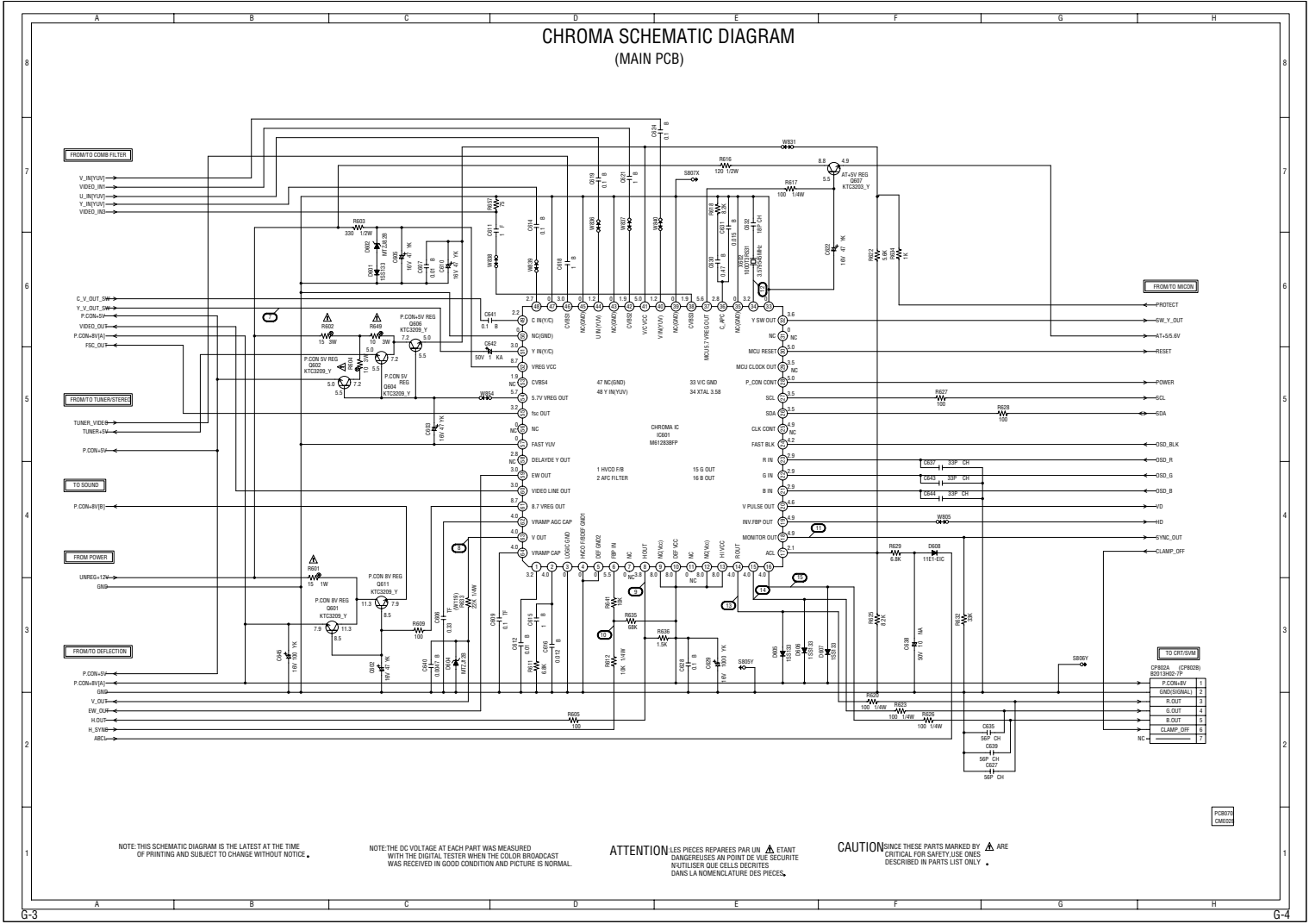

NOTE: THIS SCHEMATIC DIAGRAM IS THE LATEST AT THE TIME OF PRINTING AND SUBJECT TO CHANGE WITHOUT NOTICE.

NOTE: THE DC VOLTAGE AT EACH PART WAS MEASURED WITH THE DIGITAL TESTER WHEN THE COLOR BROADCAST WAS RECEIVED IN GOOD CONDITION AND PICTURE IS NORMAL.

ATTENTION LES PIÈCES RÉPARÉES PAR UN ETANT DANGEREUSES AN POINT DE VUE SECURITE UTILISER QUE CELLES DECRIES DANS LA NOMENCLATURE DES PIÈCES.

CAUTION SINCE THESE PARTS MARKED BY ARE CRITICAL FOR SAFETY USE ONES DESCRIBED IN PARTS LIST ONLY.

POWER SCHEMATIC DIAGRAM (MAIN PCB)

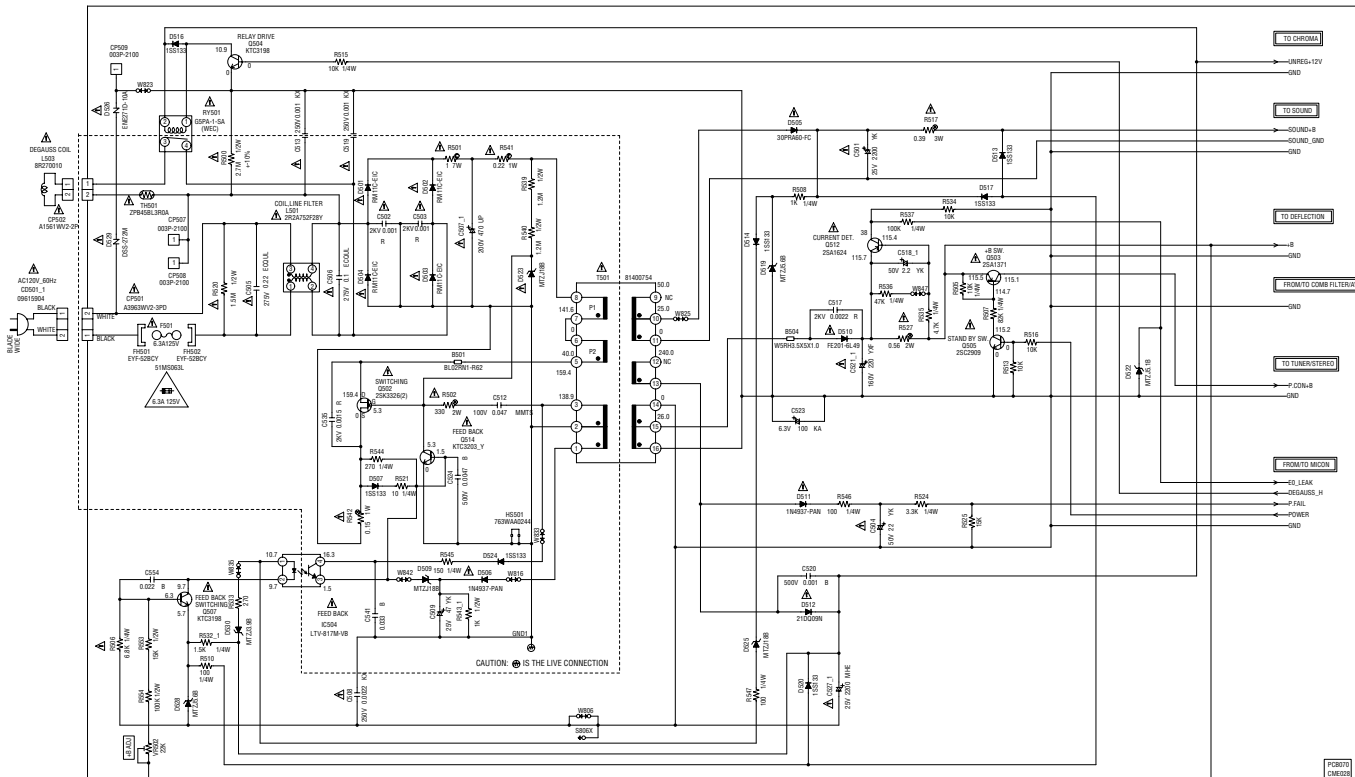

CAUTION FOR CONTINUED PROTECTION AGAINST FIRE HAZARD, REPLACE ONLY WITH THE SAME TYPE FUSE 6.3A 125V(F501)

NOTE: THIS SCHEMATIC DIAGRAM IS THE LATEST AT THE TIME OF PRINTING AND SUBJECT TO CHANGE WITHOUT NOTICE.

NOTE: THE RESISTOR MARKED F IS FUSE RESISTOR. THE ALUMINUM ELECTROLYTIC CAPACITOR MARKED NP IS NON POLAR ONE.

ATTENTION LES PIÈCES RÉPARABLES PAR UN ETANT DANGEREUSES AU POINT DE VUE SÉCURITÉ, N'UTILISER QUE DES PIÈCES DANS LA NOMÉCLATURE DES PIÈCES.

CAUTION SINCE THESE PARTS MARKED BY ARE CRITICAL FOR SAFETY USE ONLY DESCRIBED IN PARTS LIST ONLY.

ATTENTION POUR UNE PROTECTION CONTINUE LES RISQUES D'INCENDIE N'UTILISER QUE DES FUSIBLES DE MEME TYPE 6.3A 125V(F501)

NOTE: THE DC VOLTAGE AT EACH PART WAS MEASURED WITH THE DIGITAL TESTER WHEN THE COLOR BROADCAST WAS RECEIVED IN GOOD CONDITION AND PICTURE IS NORMAL.

SOUND SCHEMATIC DIAGRAM (MAIN PCB)

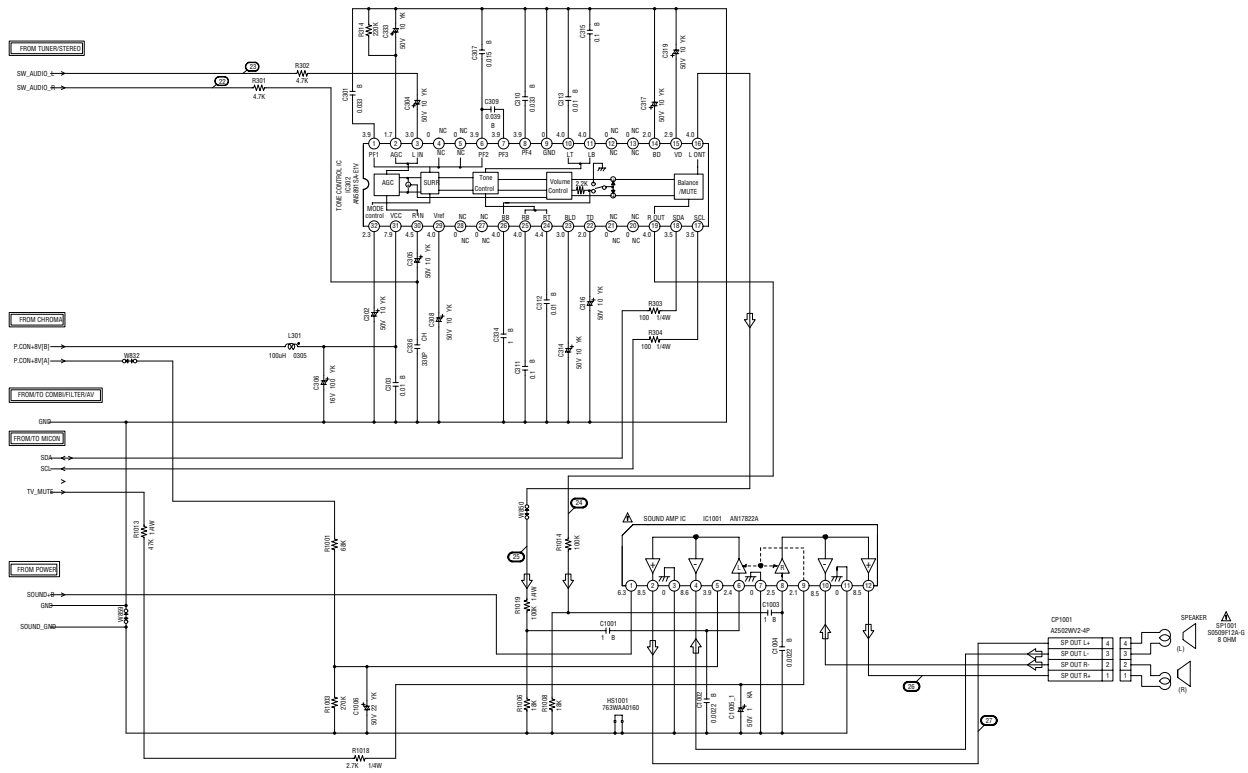

NOTE: THIS SCHEMATIC DIAGRAM IS THE LATEST AT THE TIME OF PRINTING AND SUBJECT TO CHANGE WITHOUT NOTICE.

NOTE: THE DC VOLTAGE AT EACH PART WAS MEASURED WITH THE DIGITAL TESTER WHEN THE COLOR BROADCAST WAS RECEIVED IN GOOD CONDITION AND PICTURE IS NORMAL.

ATTENTION LES PIÈCES RÉPARÉES PAR UN ÉTANT DANGEREUSES AU POINT DE VUE SÉCURITÉ N'UTILISER QUE DES PIÈCES SÉCURITÉES DANS LA NOMÉCLATURE DES PIÈCES.

CAUTION SINCE THESE PARTS MARKED BY ARE CRITICAL FOR SAFETY USE ONES DESCRIBED IN PARTS LIST ONLY.

← AUDIO SIGNAL

PCB070
CHECKED

TUNER/STEREO SCHEMATIC DIAGRAM (MAIN PCB)

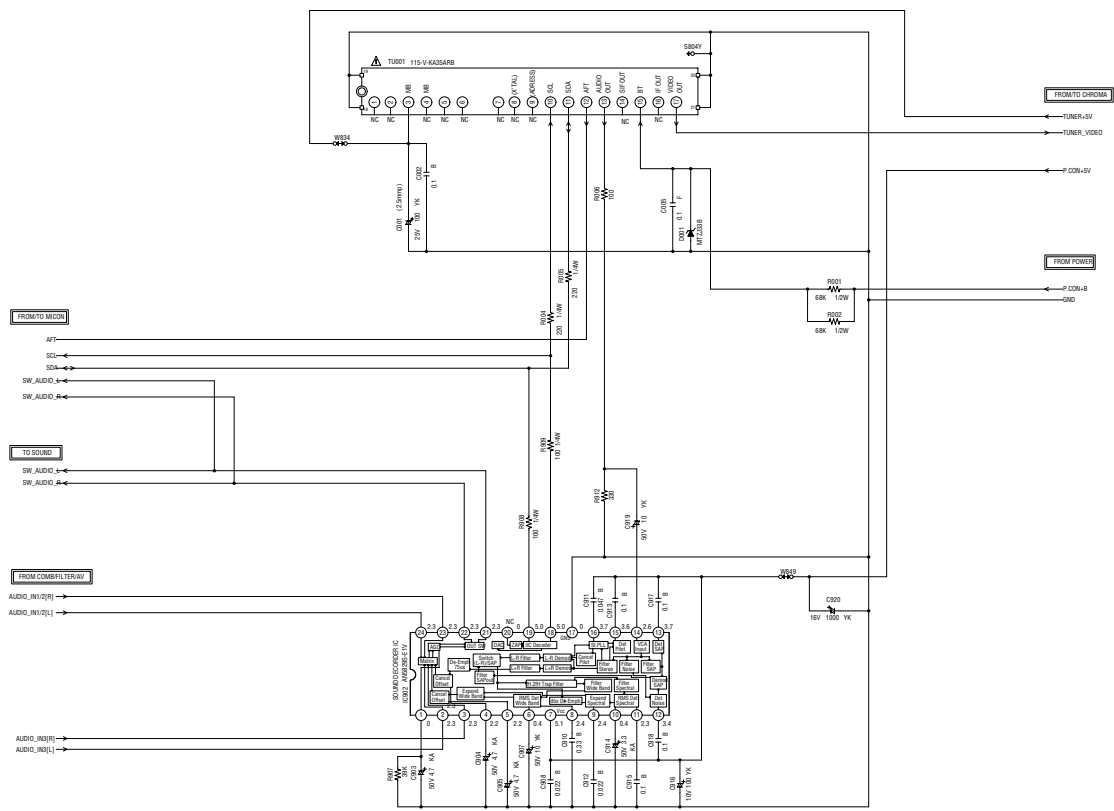

NOTE: THIS SCHEMATIC DIAGRAM IS THE LATEST AT THE TIME OF PRINTING AND SUBJECT TO CHANGE WITHOUT NOTICE.

NOTE: THE DC VOLTAGE AT EACH PART WAS MEASURED WITH THE DIGITAL TESTER WHEN THE COLOR BROADCAST WAS RECEIVED IN GOOD CONDITION AND PICTURE IS NORMAL.

ATTENTION: LES PIÈCES RÉPARÉES PAR UN ÉTANT DANGEREUSES AN POINT DE VUE SÉCURITÉ, UTILISEZ-LES QUE CELLES DÉCRITES DANS LA NOMÉNCLATURE DES PIÈCES.

CAUTION: SINCE THESE PARTS MARKED BY ARE CRITICAL FOR SAFETY USE ONES DESCRIBED IN PARTS LIST ONLY.

PCB070
CH0005

COMB/FILTER/AV SCHEMATIC DIAGRAM (MAIN PCB)

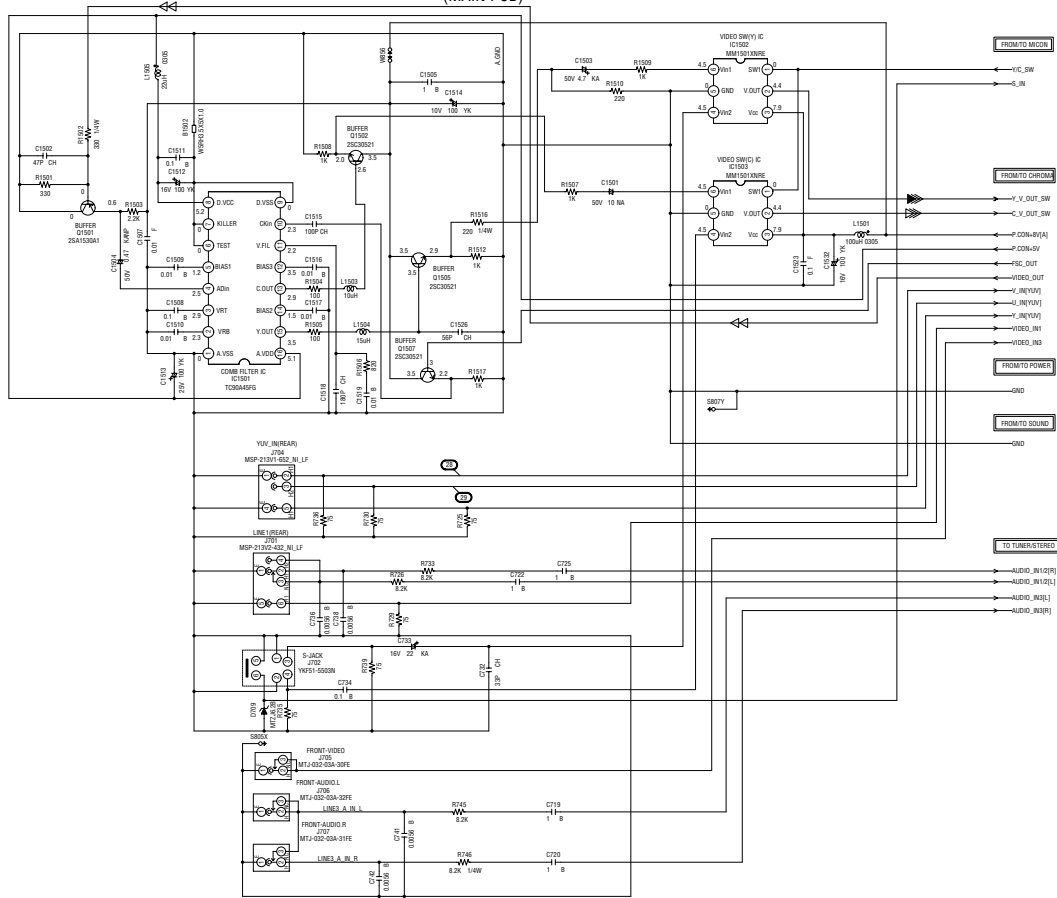

NOTE: THIS SCHEMATIC DIAGRAM IS THE LATEST AT THE TIME OF PRINTING AND SUBJECT TO CHANGE WITHOUT NOTICE.

NOTE: THE DC VOLTAGE AT EACH PART WAS MEASURED WITH THE DIGITAL TESTER WHEN THE COLOR BROADCAST WAS RECEIVED IN GOOD CONDITION AND PICTURE IS NORMAL.

◀ LUMINANCE SIGNAL
 ◀◀ COLOR SIGNAL
 ◀◀◀ TUNER VIDEO SIGNAL

PCB070
 CH020

WAVEFORMS

MICON

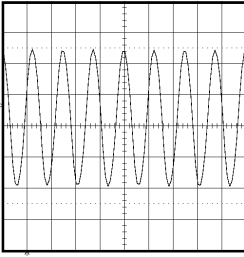

① 1V 0.1 μ s/div

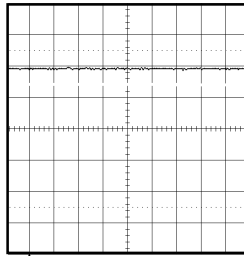

② 1V 1 μ s/div

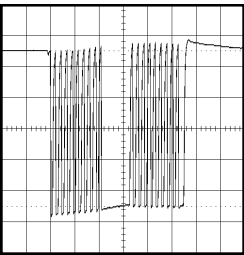

③ 1V 50 μ s/div

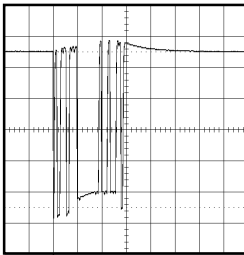

④ 1V 0.1ms/div

CHROMA

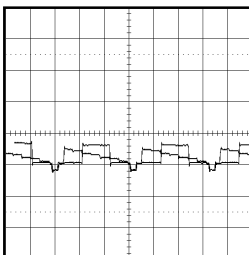

⑦ 1V 20 μ s/div

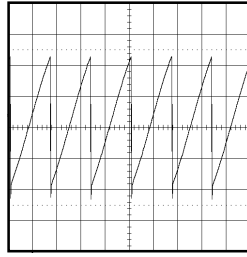

⑧ 0.5V 10ms/div

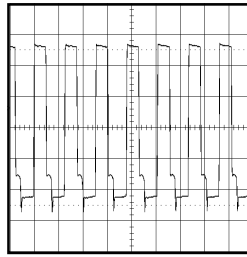

⑨ 1V 50 μ s/div

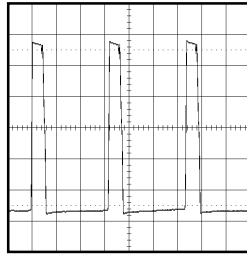

⑩ 2V 20 μ s/div

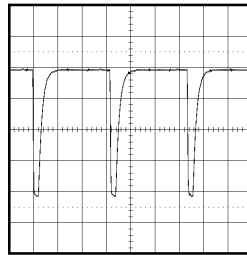

⑪ 0.5V 20 μ s/div

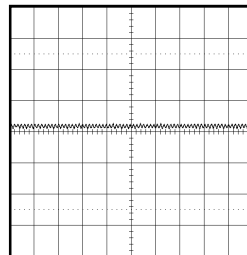

⑫ 1V 2 μ s/div

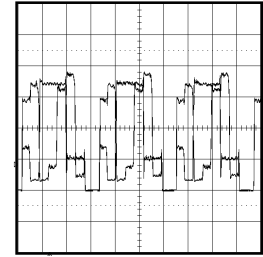

⑬ 1V 20 μ s/div

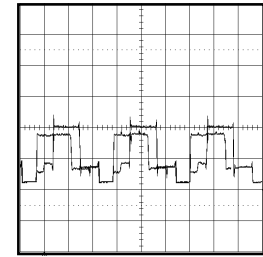

⑭ 2V 20 μ s/div

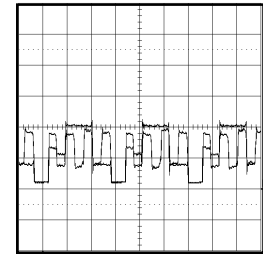

⑮ 2V 20 μ s/div

DEFLECTION

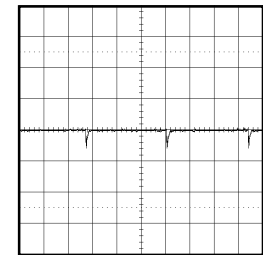

⑯ 2V 5ms/div

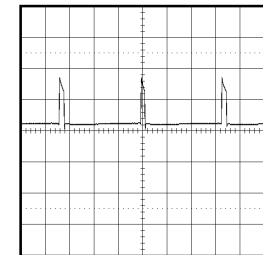

⑰ 20V 5ms/div

NOTE: The following waveforms were measured at the point of the corresponding balloon number in the schematic diagram.

WAVEFORMS

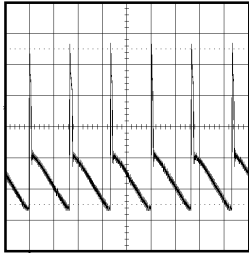

⑱ 10V 10ms/div

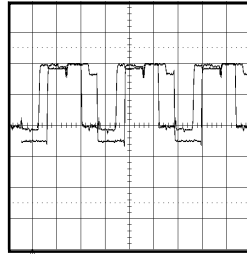

⑳ 50V 20 μ s/div

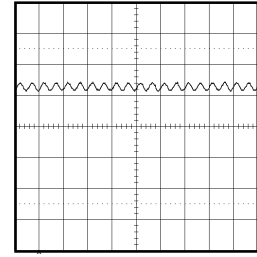

㉑ 2V 5ms/div

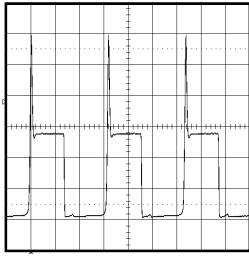

㉒ 20V 20 μ s/div

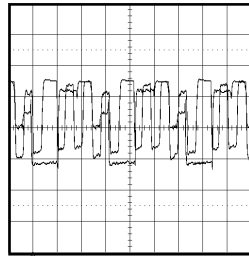

㉓ 50V 20 μ s/div

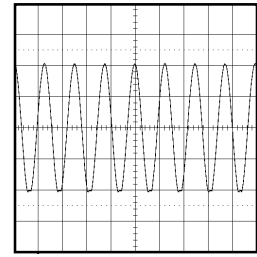

㉔ 5V 2ms/div

SOUND

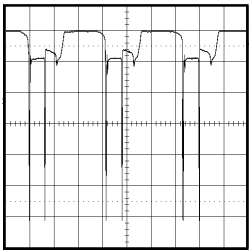

㉕ 2V 20 μ s/div

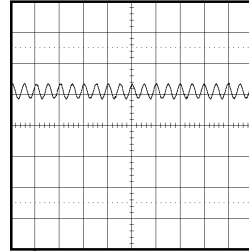

㉖ 2V 5ms/div

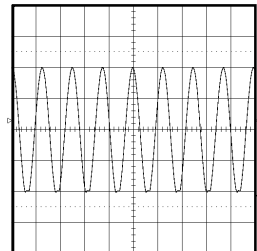

㉗ 5V 2ms/div

COMB/FILTER/AV

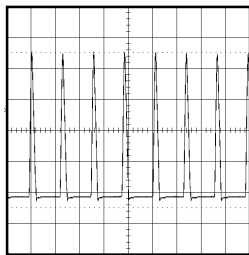

㉘ 200V 50 μ s/div

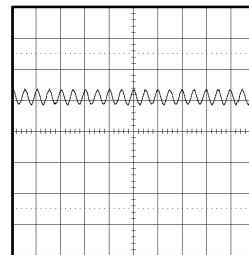

㉙ 2V 5ms/div

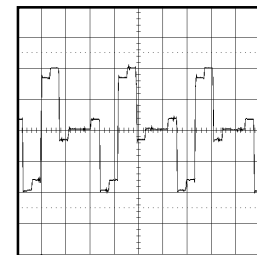

㉚ 200mV 20 μ s/div

CRT/SVM

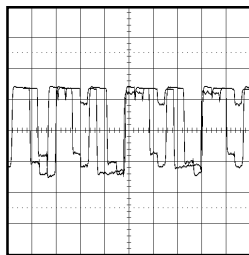

㉛ 50V 20 μ s/div

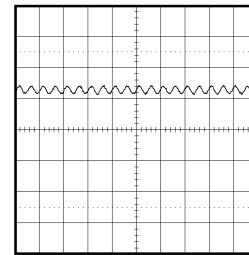

㉜ 2V 5ms/div

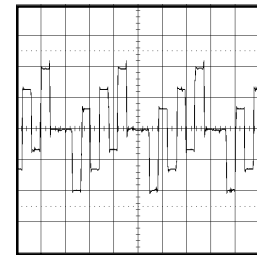

㉝ 200mV 20 μ s/div

NOTE: The following waveforms were measured at the point of the corresponding balloon number in the schematic diagram.

MECHANICAL EXPLODED VIEW

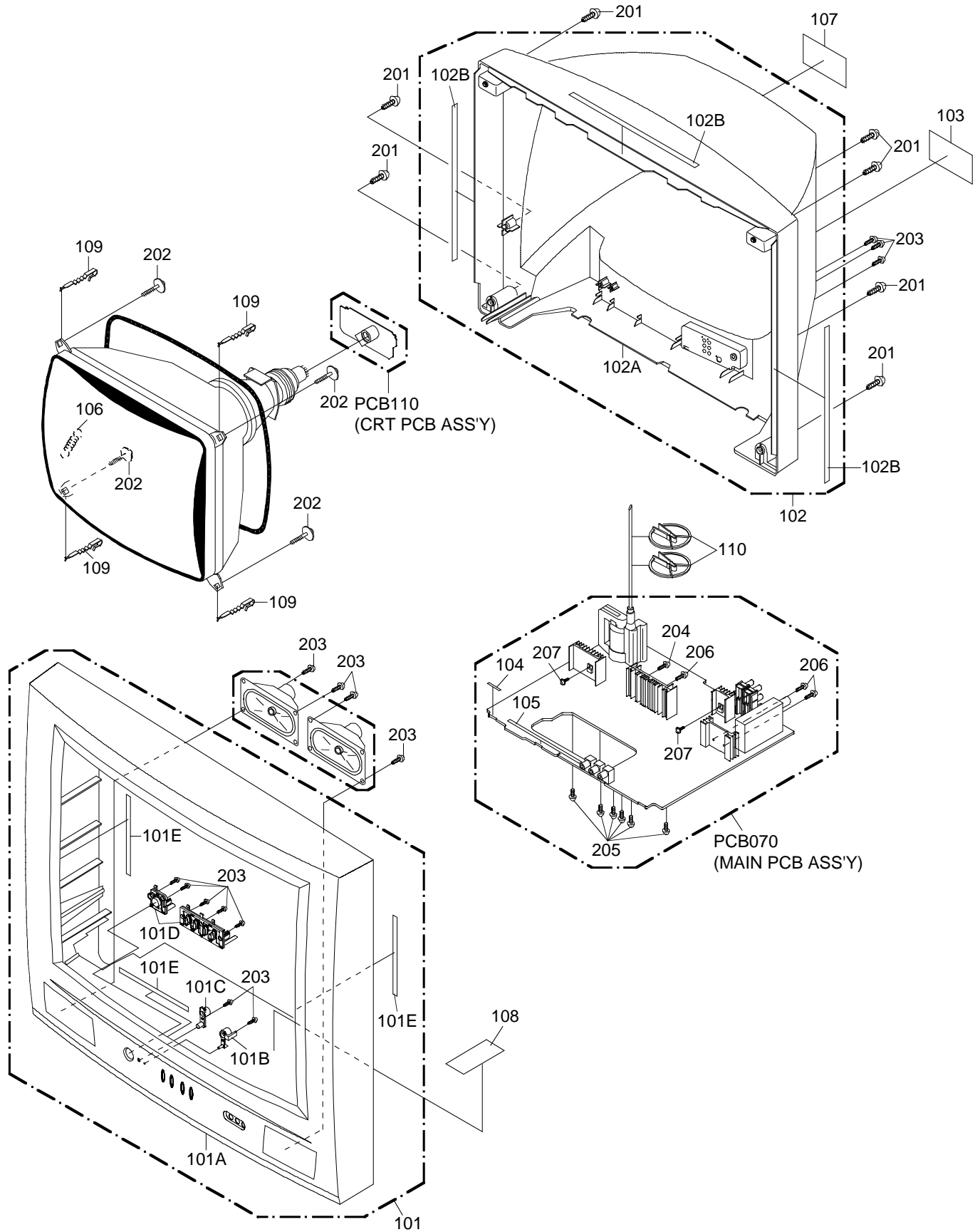

MECHANICAL EXPLODED VIEW (PACKING DIAGRAM)

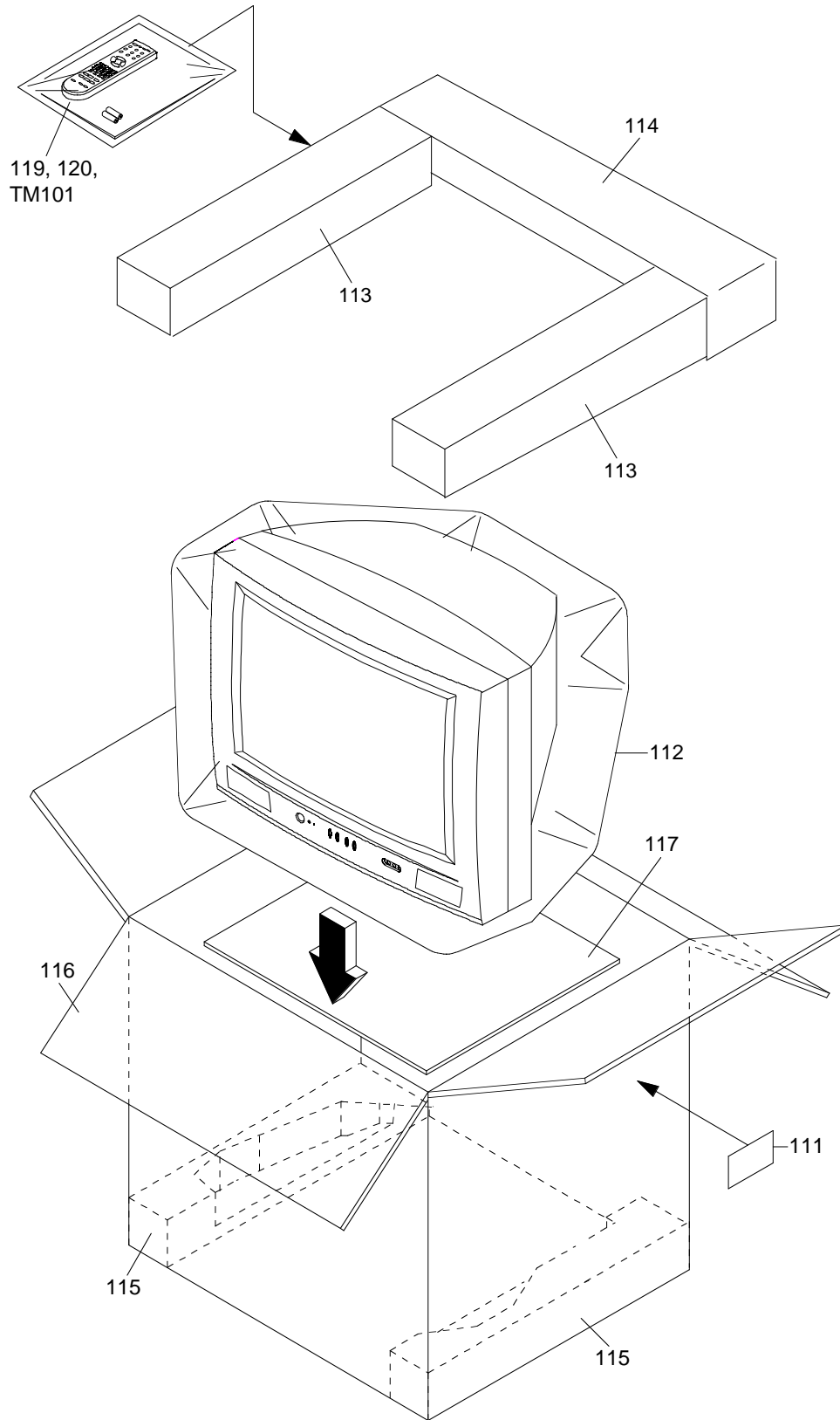

MECHANICAL REPLACEMENT PARTS LIST

Location No.	TSB P/N	Reference No.	Description	
101	AE007480	7A701A428A	FRONT CABI ASS'Y	
101A	AE007471	701WPJD031	CABINET,FRONT	
101B	AE007473	713WPAA171	GLASS,LED	
101C	AE007474	713WPAA172	GUIDE,REMOCON	
101D	AE007477	735WPBB400	BUTTON ASS'Y	
101E	AE003071	800WQ0A041	FELT SHEET	
102	AE007481	7A702A143A	BACK CABI ASS'Y	
102A	AE007472	702WPAA884	CABINET,BACK	
102B	AE006226	800WQ0A090	FELT SHEET	
103	AE006143	72600A094	SHEET,CRT SERVICEMAN	
104	AE003190	800WQ0A067	FELT SHEET	
105	AE007482	800WQ0A068	FELT SHEET	
106	BZ710660	741WUA0021	SPRING,EARTH	
107	AE007475	722549A466	SHEET,RATING	
108	AE006088	72400A006	SHEET,CSA	
109	AD300768	762WPA0009	HOLDER,CRT WIRE	
110	BZ710260	899HV3T000	HOLDER,ANODE WIRE	
111	AE007476	723000C923	SHEET,BAR CODE	
112	AE006145	791WHAA116	FILM BAG	
113	AE003356	792WHAA091	PACKAGE,TOP	
114	AE003357	792WHAA092	PACKAGE,BACK	
115	AE003358	792WHAA093	PACKAGE,BOTTOM	
116	AE007478	793WCDC733	GIFT BOX	
117	AE007479	795WCDA012	PAD	
118	AE007486	A3U5012975	INSTRUCTION BOOK KIT	
119	AE007492	JA4ND100	POLYBAG,INSTRUCTION(RED CAUTION)	
120	AE007491	J3U50121A	INSTRUCTION BOOK	
201	AE003522	8117540B0U	SCREW,TAP TITE(B0) TRUSS	4x20
202	AE004848	8141H60D5U	SCREW,TAP TITE(P) GW20	6x45
203	AE003528	8110630A0U	SCREW,TAP TITE(P) BRAZIER	3x10
204	AE003524	8109I30A0U	SCREW,TAP TITE(B) WH7	3x10
205	AE005917	810963080Q	SCREW,TAP TITE(B) BRAZIER	3x8
206	AE003531	810763080U	SCREW,TAP TITE(S) BRAZIER	3x8
207	AE005659	8109I3080U	SCREW,TAP TITE(B) WH7	3x8

ELECTRICAL REPLACEMENT PARTS LIST

Location No.	TSB P/N	Reference No.	Description
RESISTORS			
△R410	AD302107	R3X18A470J	R,METAL OXIDE 47 OHM 2W
△R416	BZ210053	R002T22R2J	RC 2.2 OHM 1/2W
△R420	BZ210053	R002T22R2J	RC 2.2 OHM 1/2W
△R426	BZ210030	R4X5T4472F	R,METAL 4.7K OHM 1/4W
△R434	AD301972	R5X2CF5R6J	R,CEMENT 5.6 OHM 10W
△R436	BZ210023	R4X5T4183F	R,METAL 18K OHM 1/4W
△R438	AE003588	R65581010J	R,FUSE 1 OHM 1W
△R439	AE005687	R3K581102J	R,METAL OXIDE 1K OHM 1W
△R441	BZ210231	R4X5T6153F	R,METAL 15K OHM 1/6W
△R452	AD301344	R3X18A151J	R,METAL OXIDE 150 OHM 2W
△R459	AE003590	R655822R2J	R,FUSE 2.2 OHM 1/2W
△R500	BZ210080	R0G3K2275K	RC 2.7M OHM 1/2W
△R501	AD301596	R5X2AE010J	R,CEMENT 1 OHM 7W
△R502	BZ210249	R3X28A331J	R,METAL OXIDE 330 OHM 2W
△R506	BZ210162	R002T4682J	RC 6.8K OHM 1/4W
△R517	AD302108	R3X28BR39J	R,METAL OXIDE 0.39 OHM 3W
△R520	BZ210206	R002T2155J	RC 1.5M OHM 1/2W
△R527	BZ210165	R3X18AR56J	R,METAL OXIDE 0.56 OHM 2W
R532	AE007495	R00202152J	RC 1.5K OHM 1/2W
△R541	AE005735	R63881R22J	R,FUSE 0.22 OHM 1W
△R542	BZ210248	R3X181R15J	R,METAL OXIDE 0.15 OHM 1W
R543	AE007494	R00202102J	RC 1K OHM 1/2W
△R601	AE006340	R3X181150J	R,METAL OXIDE 15 OHM 1W
△R602	AD302352	R3X28B150J	R,METAL OXIDE 15 OHM 3W
△R604	BZ210215	R3X28B100J	R,METAL OXIDE 10 OHM 3W
△R649	BZ210215	R3X28B100J	R,METAL OXIDE 10 OHM 3W
△R803	BZ210050	R3X18A123J	R,METAL OXIDE 12K OHM 2W
△R805	BZ210050	R3X18A123J	R,METAL OXIDE 12K OHM 2W
△R807	BZ210050	R3X18A123J	R,METAL OXIDE 12K OHM 2W
R1018	AE007496	R00204272J	RC 2.7K OHM 1/4W
CAPACITORS			
△C408	BZ110032	E5EZF3102M	CE 1000 UF 25V
△C412	AD301599	P4N8FJ272H	CMPP 0.0027UF 1.25KV
△C413	AD300067	E02LF4102M	CE 1000 UF 35V
C418	AE001019	P4J7F3434J	CMPP 0.43 UF 250V PMS
△C420	AE007493	P4G8FJ153H	CMPP 0.015 UF 1.25KV PHE
△C421	AD300048	P3N1F5183J	CCP 0.018 UF 630V
C425	AE007487	C03L0R7S2K	CC 560 PF 2KV R
△C426	BZ110225	E5EZF220M	CE 22 UF 250V
△C430	BZ110195	E02LU8220M	CE 22 UF 100V
C442	AE006084	E736F56R8M	CE 6.8 UF 50V
△C501	BZ210176	E02LF3222M	CE 2200 UF 25V
△C502	BZ110202	COPLRR713K	CC 0.001 UF 2KV R
△C503	BZ110202	COPLRR713K	CC 0.001 UF 2KV R
△C504	BZ110205	E02LU5220M	CE 22 UF 50V
△C505	BZ110025	P2122B224M	CMP 0.22 UF 275V ECQUL
△C506	BZ110035	P2122B104M	CMP 0.1 UF 275V ECQUL
△C507	BZ110012	E51CGC471M	CE 470 UF 200V
△C508	BZ110222	CD39E0MH3M	CC 0.0022UF 250V
△C513	AD301026	CD39E0M13M	CC 0.001 UF 250V
△C517	BZ110181	C03L0R7H3K	CC 0.0022UF 2KV R
△C519	AD301026	CD39E0M13M	CC 0.001 UF 250V
△C521	BZ110228	E62NFB221M	CE 220 UF 160V
C523	AE007490	E52H00101M	CE 100 UF 6.3V
△C527	BZ110101	E5EZF3222M	CE 2200 UF 25V
△C535	AE000874	COPLRR7E3K	CC 0.0015 UF 2KV R
C640	AE007488	CQG0B04Q3K	CC 0.0047UF 50V B
C802	BZ110247	C0JBB0713K	CC 0.001 UF 2KV B
C920	BZ110250	E02L02102M	CE 1000 UF 16V
DIODES			
D001	BZ410037	D97U03301B	DIODE,ZENER MTZJ33B T-77
D104	BZ410006	D1VT001330	DIODE,SILICON 1SS133T-77
D105	BZ410006	D1VT001330	DIODE,SILICON 1SS133T-77
D106	BZ410020	D97U05R11B	DIODE,ZENER MTZJ5.1B T-77
D107	BZ410006	D1VT001330	DIODE,SILICON 1SS133T-77
D108	BZ410006	D1VT001330	DIODE,SILICON 1SS133T-77
D109	BZ410054	0021721150	LED SLR-342VCT32
D110	BZ410006	D1VT001330	DIODE,SILICON 1SS133T-77
D402	BZ410043	D2WT011E10	DIODE,SILICON 11E1-EIC
D403	BZ410019	D97U03001B	DIODE,ZENER MTZJ30B T-77
D404	BZ410020	D97U05R11B	DIODE,ZENER MTZJ5.1B T-77

ELECTRICAL REPLACEMENT PARTS LIST

Location No.	TSB P/N	Reference No.	Description
TRANSISTORS			
Q411	AE005873	T8RA030520	TRANSISTOR,SILICON
△Q502	BZ510098	T220033260	FET
△Q503	BZ510005	TA3T1371A0	TRANSISTOR,SILICON
Q504	BZ510069	TCATC31980	TRANSISTOR,SILICON
△Q505	BZ510011	TC3T029090	TRANSISTOR,SILICON
△Q507	BZ510069	TCATC31980	TRANSISTOR,SILICON
△Q512	BZ510004	TA3T016240	TRANSISTOR,SILICON
△Q514	BZ510070	TCAT032034	TRANSISTOR,SILICON
Q601	BZ510105	TCAT03209Y	TRANSISTOR,SILICON
Q602	BZ510105	TCAT03209Y	TRANSISTOR,SILICON
Q604	BZ510105	TCAT03209Y	TRANSISTOR,SILICON
Q606	BZ510105	TCAT03209Y	TRANSISTOR,SILICON
Q607	BZ510070	TCAT032034	TRANSISTOR,SILICON
Q611	BZ510105	TCAT03209Y	TRANSISTOR,SILICON
△Q801	BZ510100	TCATC3199Y	TRANSISTOR,SILICON
△Q802	BZ510100	TCATC3199Y	TRANSISTOR,SILICON
△Q803	BZ510100	TCATC3199Y	TRANSISTOR,SILICON
△Q804	BZ510091	TCA0042170	TRANSISTOR,SILICON
△Q805	BZ510091	TCA0042170	TRANSISTOR,SILICON
△Q806	BZ510091	TCA0042170	TRANSISTOR,SILICON
Q1501	AE005872	T6RA015300	TRANSISTOR,SILICON
Q1502	AE005873	T8RA030520	TRANSISTOR,SILICON
Q1505	AE005873	T8RA030520	TRANSISTOR,SILICON
Q1507	AE005873	T8RA030520	TRANSISTOR,SILICON
COILS & TRANSFORMERS			
L301	BZ310041	02167F101J	COIL
△L402	AE006990	022810041A	COIL,LINEARITY
L403	AD301606	02DK000058	COIL,CHOKE
△L501	AD301124	029T000101	COIL,LINE FILTER
△L503	AD301607	028R270010	COIL,DEGAUSS
L1501	BZ310041	02167F101J	COIL
L1503	AD301445	021LA6100J	COIL
L1504	AD300910	021LA6150J	COIL
L1505	BZ310039	02167F220J	COIL
T401	BZ310189	0450190161	TRANS,HORIZONTAL DRIVE
△T501	AE007469	0481400754	TRANSFORMER,SWITCHING
JACKS			
J701	AE002759	060J431020	RCA JACK
J702	AE006074	063Q700011	JACK
J704	AE002761	060J411032	RCA JACK
J705	AE004756	060J401104	RCA JACK
J706	AE004758	060J401106	RCA JACK
J707	AE004757	060J401105	RCA JACK
△J801	AD301356	066F130020	SOCKET,CATHODE RAY,TUBE
SWITCHES			
SW101	BZ612010	0504101T34	SWITCH,TACT
SW102	BZ612010	0504101T34	SWITCH,TACT
SW103	BZ612010	0504101T34	SWITCH,TACT
SW104	BZ612010	0504101T34	SWITCH,TACT
SW105	BZ612010	0504101T34	SWITCH,TACT
VARIABLE RESISTORS			
VR401	BZ210218	V1K63H3BTE	VOLUME,SEMI FIXED
VR502	BZ210101	V1163H4BTC	VOLUME,SEMI FIXED
P.C.BOARD ASSEMBLIES			
PCB070	AE007483	A3U5012070	PCB ASS'Y
PCB110	AE007485	A3U5012110	PCB ASS'Y
MISCELLANEOUS			
B403	BZ310122	024HT03563	CORE,BEADS
△B501	BZ310045	024AT03481	CORE,BEADS
△B504	BZ310121	024HT03553	CORE,BEADS
B1502	BZ310121	024HT03553	CORE,BEADS
BT001	AE005640	141R004016	BATTERY,MANGAN
BT002	AE005640	141R004016	BATTERY,MANGAN
△CD501	AE006077	1209615904	CORD,AC BUSH
CD801	BZ614403	WCL6842038	FLAT CABLE AWM2468 A
CD802	AE005282	WEL6854038	FLAT CABLE AWM2468 A
CD803	AE005637	06CH823004	CORD,CONNECTOR
CP101	AE001188	069S270639	CONNECTOR PCB SIDE
△CP401	AE004859	069S460089	CORD,UX CONNECTOR
△CP501	BZ614176	069S320419	CONNECTOR PCB SIDE
△CP502	BZ614283	069S420110	CONNECTOR PCB SIDE

ELECTRICAL REPLACEMENT PARTS LIST

Location No.	TSB P/N	Reference No.	Description
COILS & TRANSFORMERS			
CP507	BZ614016	069W01001A	CONNECTOR PCB SIDE 003P-2100
CP508	BZ614016	069W01001A	CONNECTOR PCB SIDE 003P-2100
CP509	BZ614016	069W01001A	CONNECTOR PCB SIDE 003P-2100
CP803	BZ614269	069S320010	CONNECTOR PCB SIDE A2361WV2-2P
CP1001	AD301045	069S140419	CONNECTOR PCB SIDE A2502WV2-4P
CP801A	BZ614276	067U005049	WIRE HOLDER B2013H02-5P
CP801B	BZ614276	067U005049	WIRE HOLDER B2013H02-5P
CP802A	AD301997	067U007029	WIRE HOLDER B2013H02-7P
CP802B	AD301997	067U007029	WIRE HOLDER B2013H02-7P
EL0701	BZ614043	124116281A	EYE LET XRY16X28BD
EL0702	BZ614044	124120301A	EYE LET XRY20X30BD
△F501	BZ614422	081PC6R305	FUSE 51MS063L
△FB401	AE007468	043227020Y	TRANSFORMER,FLYBACK 3227020Y
FH501	AE002634	06710T0009	HOLDER,FUSE EYF-52BCY
FH502	AE002634	06710T0009	HOLDER,FUSE EYF-52BCY
OS101	AD301048	0773071001	REMOTE RECEIVER RPM7138-WH5
△RY501	AE006070	0560X20118	RELAY G5PA-1-SA(WEC)
△SP1001	AE007470	070Y435021	SPEAKER S0509F12A-G
△TH501	BZ410079	DF5EL3R0A0	DEGAUSS ELEMENT ZPB45BL3R0A
TM101	AD302093	076N0GQ010	TRANSMITTER RC-GQ010
△TU001	AE006069	0163300018	RF UNIT 115-V-KA35ARB
△V801	AD301614	0981270B01	CRT W/DY M68LWF088X50
X101	AD302002	100CT8R005	CRYSTAL HC-49/U-S
X602	AD301653	100DT3R531	CRYSTAL HC-49/U
RESISTOR			
	RC.....	CARBON RESISTOR	
CAPACITORS			
	CC.....	CERAMIC CAPACITOR	
	CE.....	ALUMI ELECTROLYTIC CAPACITOR	
	CP.....	POLYESTER CAPACITOR	
	CPP.....	POLYPROPYLENE CAPACITOR	
	CPL.....	PLASTIC CAPACITOR	
	CMP.....	METAL POLYESTER CAPACITOR	
	CMPL.....	METAL PLASTIC CAPACITOR	
	CMPP.....	METAL POLYPROPYLENE CAPACITOR	

TOSHIBA CORPORATION

1-1, SHIBAURA 1-CHOME, MINATO-KU, TOKYO 105-8001, JAPAN