

SERVICE MANUAL

AA-2 CHASSIS

<u>MODEL</u>	<u>COMMANDER</u>	<u>DEST.</u>	<u>CHASSIS NO.</u>
<i>KV-35V35</i>	<i>RM-Y137</i>	<i>US</i>	<i>SCC-J71E-A</i>
<i>KV-35V35</i>	<i>RM-Y137</i>	<i>Canadian</i>	<i>SCC-J73D-A</i>
<i>KV-35V75</i>	<i>RM-Y137</i>	<i>US</i>	<i>SCC-J71F-A</i>
<i>KV-35V45</i>	<i>RM-Y137</i>	<i>Canadian</i>	<i>SCC-J73E-A</i>

<u>MODEL</u>	<u>COMMANDER</u>	<u>DEST.</u>	<u>CHASSIS NO.</u>
--------------	------------------	--------------	--------------------

Note :

1. Adjustment Manual for this model is separately published.

	Adjustment Manual
Part No.	9-965-821-01

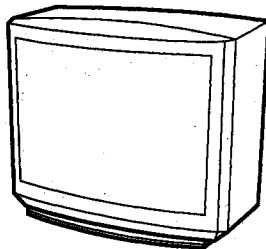
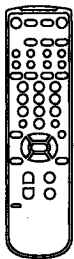

KV-35V35

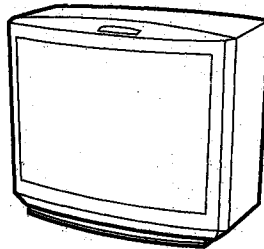

KV-35V45

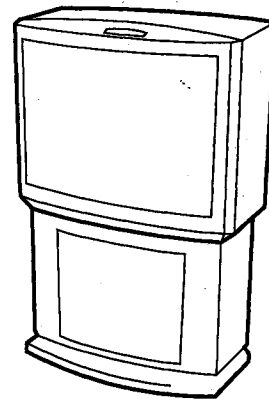

KV-35V75



TRINITRON® COLOR TV
SONY®

※ Please file according to model size. ■

SPECIFICATIONS

	Model num.						KV-35V35	KV-35V45	KV-35V75
Television system	American TV standard								
Channel coverage	VHF: 2-13 / UHF: 14-69 / CATV: 1-125								
Antenna	75-ohm external antenna terminal for VHF/UHF								
Picture tube	Hi Black Trinitron® tube								
Screen size (in.)							35-inch picture measured diagonally		
Power requirements							120 V, 60 Hz	120 V, 60 Hz	120 V, 60 Hz
Number of inputs/outputs									
Video¹⁾							3	3	3
S video²⁾							1	2	2
Audio³⁾							3	3	3
Audio out⁴⁾							1	1	1
Monitor out¹⁾							1	1	1
TV out¹⁾							-	1	1
S-Link							•	•	•
Speaker output (W)							5W × 2	10W × 2	10W × 2
Power consumption (W) When in use (Max.) in standby							215W, 2.80 A 13W	225W, 2.90 A 13W	225W 13W
Dimensions (W/H/D) (mm) (in.)							920 × 730.8 × 641.8 mm 37 ⁵ / ₈ × 29 ⁷ / ₈ × 26 ¹ / ₄ in.	920 × 730.8 × 641.8 mm 37 ⁵ / ₈ × 29 ⁷ / ₈ × 26 ¹ / ₄ in.	920 × 1207 × 713 mm 37 ⁵ / ₈ × 49 ³ / ₈ × 28 ¹ / ₈ in.
Mass (kg) (lbs)							90 kg 198 lbs 7 oz	90 kg 198 lbs 7 oz	130 kg 279 lbs 6 oz

- ¹⁾ 1 Vp-p, 75 ohms unbalanced, sync negative
- ²⁾ Y: 1 Vp-p, 75 ohms unbalanced, sync negative
 C: 0.286 Vp-p (Burst signal), 75 ohms
- ³⁾ 500 mVrms (100% modulation), Impedance: 47 kilohms
- ⁴⁾ More than 408 mVrms at the maximum volume setting (variable)
 More than 408 mVrms (fix)
 Impedance: 5 kilohms

Supplied accessories

Remote commander

RM-Y137 (1)

35V35/35V45/35V75

Size AA (R6) battery (2)

Optional accessories

Connecting cables VMC-810S/820S, VMC-720M, YC-15V/30V, RK-74A

TV Stand SU-35A (KV-35V35/35V45 only)

U/V mixer EAC-66

Design and specifications are subject to change without notice.

(●)[®] SRS (SOUND RETRIEVAL SYSTEM)

The (●) SRS (SOUND RETRIEVAL SYSTEM) is manufactured by Sony Corporation under license from SRS Labs, Inc. It is covered by U.S. Patent No. 4,748,669. Other U.S. and foreign patents pending.

The word 'SRS' and the SRS symbol (●) are registered trademarks of SRS Labs, Inc.

SAFETY CHECK-OUT

(US model only)

After correcting the original service problem, perform the following safety checks before releasing the set to the customer:

1. Check the area of your repair for unsoldered or poorly-soldered connections. Check the entire board surface for solder splashes and bridges.
2. Check the interboard wiring to ensure that no wires are "pinched" or contact high-wattage resistors.
3. Check that all control knobs, shields, covers, ground straps, and mounting hardware have been replaced. Be absolutely certain that you have replaced all the insulators.
4. Look for unauthorized replacement parts, particularly transistors, that were installed during a previous repair. Point them out to the customer and recommend their replacement.
5. Look for parts which, through functioning, show obvious signs of deterioration. Point them out to the customer and recommend their replacement.
6. Check the line cords for cracks and abrasion. Recommend the replacement of any such line cord to the customer.
7. Check the condition of the monopole antenna (if any). Make sure the end is not broken off, and has the plastic cap on it. Point out the danger of impalement on a broken antenna to the customer, and recommend the antenna's replacement.
8. Check the B+ and HV to see they are at the values specified. Make sure your instruments are accurate; be suspicious of your HV meter if sets always have low HV.
9. Check the antenna terminals, metal trim, "metallized" knobs, screws, and all other exposed metal parts for AC leakage. Check leakage as described below.

LEAKAGE TEST

The AC leakage from any exposed metal part to earth ground and from all exposed metal parts to any exposed metal part having a return to chassis, must not exceed 0.5mA (500 microamperes). Leakage current can be measured by any one of three methods.

1. A commercial leakage tester, such as the Simpson 229 or RCA WT-540A. Follow the manufacturers' instructions to use these instruments.
2. A battery-operated AC milliammeter. The Data Precision 245 digital multimeter is suitable for this job.
3. Measuring the voltage drop across a resistor by means of a VOM or battery-operated AC voltmeter. The "limit" indication is 0.75V, so analog meters must have an accurate low-voltage scale. The Simpson 250 and Sanwa SH-63Trd are examples of a passive VOM that is suitable. Nearly all battery operated digital multimeters that have a 2V AC range are suitable. (See Fig. A)

HOW TO FIND A GOOD EARTH GROUND

A cold-water pipe is guaranteed earth ground; the cover-plate retaining screw on most AC outlet boxes is also at earth ground. If the retaining screw is to be used as your earth-ground, verify that it is at ground by measuring the resistance between it and a cold-water pipe with an ohmmeter. The reading should be zero ohms. If a cold-water pipe is not accessible, connect a 60-100 watts trouble light (not a neon lamp) between the hot side of the receptacle and the retaining screw. Try both slots, if necessary, to locate the hot side of the line, the lamp should light at normal brilliance if the screw is at ground potential. (See Fig. B)

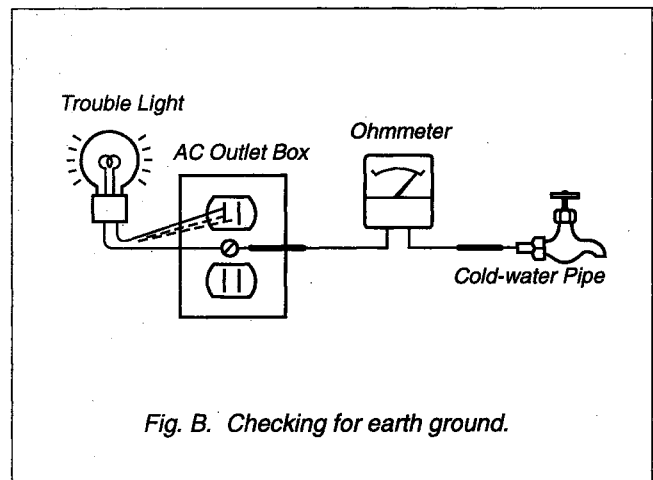
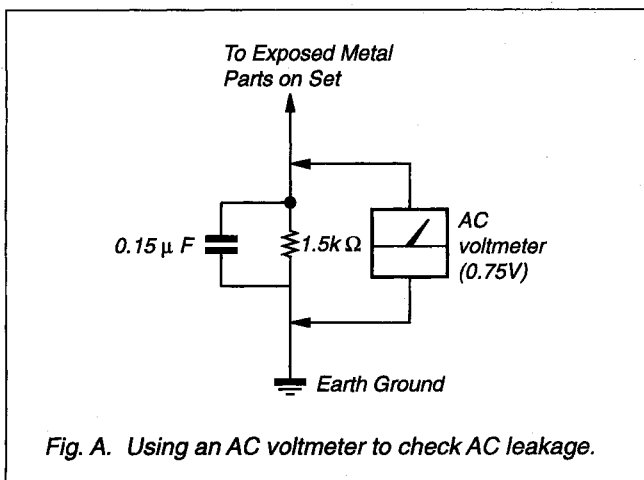

TABLE OF CONTENTS

1. GENERAL

Step 1: Hookup	5
Step 2: Installing the glass door and adjusting the shelf	8
Step 3: Setting up the remote commande	9
Step 4: Setting up the TV automatically(AUTO SET UP)	10
Changing the menu language	11
Adjusting the tilt of the picture(TILT CORRECTION)	11
Watching the TV	12
Watching two programs at a time-PIP	13
Adjusting the picture (VIDEO)	13
Selecting the video mode (VIDEO)	14
Adjusting picture brightness automatically (LIGHTSENSOR)	14
Adjusting the sound (AUDIO)	14
Using audio effect (EFFECT)	15
Selecting stereo or bilingual programs (MTS)	15
Setting the speaker switch (SPEAKER)	16
Setting audio out (AUDIO OUT)	16
Setting daylight saving time (DAYLIGHT SAVING)	16
Setting the colck (CURRENT TIME SET)	16
Setting the timer to turn the TV on and off (ON/OFF TIMER)	17
Customizing the channel names (CHANNEL CAPTION) ..	17
Blocking out a channel (CHANNEL BLOCK)	18
Setting your favorite channels (FAVORITE CHANNEL) ...	18
Setting video labels (VIDEO LABEL)	19
Setting Caption Vision (CAPTION VISION)	19
Operating video equipment	19
Operating a cable box DBS receiver	20
Troubleshooting	21
Welcome!	21
Checking your model number	21
Additional information for code setting of the remote commander	22

(CAUTION)

SHORT CIRCUIT THE ANODE OF THE PICTURE TUBE AND THE ANODE CAP TO THE METAL CHASSIS, CRT SHIELD, OR CARBON PAINTED ON THE CRT, AFTER REMOVING THE ANODE.

WARNING!!

AN ISOLATION TRANSFORMER SHOULD BE USED DURING ANY SERVICE TO AVOID POSSIBLE SHOCK HAZARD, BECAUSE OF LIVE CHASSIS.
THE CHASSIS OF THIS RECEIVER IS DIRECTLY CONNECTED TO THE AC POWER LINE.

SAFETY-RELATED COMPONENT WARNING!!

COMPONENTS IDENTIFIED BY SHADING AND MARK Δ ON THE SCHEMATIC DIAGRAMS, EXPLODED VIEWS AND IN THE PARTS LIST ARE CRITICAL FOR SAFE OPERATION. REPLACE THESE COMPONENTS WITH SONY PARTS WHOSE PART NUMBERS APPEAR AS SHOWN IN THIS MANUAL OR IN SUPPLEMENTS PUBLISHED BY SONY. CIRCUIT ADJUSTMENTS THAT ARE CRITICAL FOR SAFE OPERATION ARE IDENTIFIED IN THIS MANUAL. FOLLOW THESE PROCEDURES WHENEVER CRITICAL COMPONENTS ARE REPLACED OR IMPROPER OPERATION IS SUSPECTED.

(ATTENTION)

APRES AVOIR DECONNECTE LE CAP DE L'ANODE, COURT-CIRCUITER L'ANODE DU TUBE CATHODIQUE ET CELUI DE L'ANODE DU CAP AU CHASSIS METALLIQUE DE L'APPAREIL, OU AU COUCHE DE CARBONE PEINTE SUR LE TUBE CATHODIQUE OU AU BLINDAGE DU TUBE CATHODIQUE.

2. DISASSEMBLY

2-1. Rear Cover and Speaker Removal	23
2-2. Cabinet Base Removal (KV-35V75)	23
2-3. Chassis Assy Removal	23
2-4. Service Position	23
2-5. Control Switch Removal	24
2-6. Picture Tube Removal	24
2-7. Picture Tube Removal	24

3. SAFETY RELATED ADJUSTMENTS

26

4. DIAGRAMS

4-1. Block Diagrams	29
4-2. Circuit Boards Location	37
4-3. Printed Wiring Boards and Schematic Diagrams	38
• P Board	38
• SC Board	41
• A Board	43
• UV Board	50
• WA BOARD	54
• HV BOARD	57
• K BOARD	59
• C BOARD	61
• G BOARD	63
• AV BOARD	66
• HS BOARD	70
4-4. Semiconductions	71

5. EXPLODED VIEWS

5-1. Chassis	73
5-2. Picture Tube	74
5-2. Cabinet Base (KV-35V75)	75

6. ELECTRICAL PARTS LIST

76

ATTENTION!!

AFIN D'EVITER TOUT RISQUE D'ELECTROCUTION PROVENANT D'UN CHÂSSIS SOUS TENSION, UN TRANSFORMATEUR D'ISOLEMENT DOIT ETRE UTILISÉ LORS DE TOUT DÉPANNAGE. LE CHÂSSIS DE CE RÉCEPTEUR EST DIRECTEMENT RACCORDÉ À L'ALIMENTATION SECTEUR.

ATTENTION AUX COMPOSANTS RELATIFS À LA SÉCURITÉ!!

LES COMPOSANTS IDENTIFIÉS PAR UNE TRAME ET PAR UNE MARQUE Δ SUR LES SCHÉMAS DE PRINCIPE, LES VUES EXPLOSÉES ET LES LISTES DE PIÈCES SONT D'UNE IMPORTANCE CRITIQUE POUR LA SÉCURITÉ DU FONCTIONNEMENT. NE LES REMPLACER QUE PAR DES COMPOSANTS SONY DONT LE NUMÉRO DE PIÈCE EST INDIQUÉ DANS LE PRÉSENT MANUEL OU DANS DES SUPPLÉMENTS PUBLIÉS PAR SONY. LES RÉGLAGES DE CIRCUIT DONT L'IMPORTANCE EST CRITIQUE POUR LA SÉCURITÉ DU FONCTIONNEMENT SONT IDENTIFIÉS DANS LE PRÉSENT MANUEL. SUIVRE CES PROCÉDURES LORS DE CHAQUE REMPLACEMENT DE COMPOSANTS CRITIQUES, OU LORSQU'UN MAUVAIS FONCTIONNEMENT EST SUSPECTÉ.

SECTION 1 GENERAL

The operation instruction mentioned here are partial abstracts from the Operating Instruction Manual. The page numbers of the Operating Instruction Manual remain as in the manual. (Part no: 3-810-852-21)

Step 1: Hookup

Although you can use either an indoor or outdoor antenna with your TV, we recommend that you connect an outdoor antenna or a cable TV system to get better picture quality.

How to connect different types of cables

The illustrations below show examples of connecting cables to the TV directly.

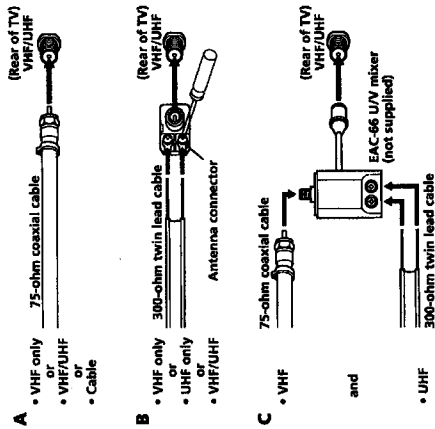

Notes

- Most VHF/UHF combination antennas have a signal splitter. Remove the splitter before attaching the appropriate connector.
- If you use the U/V mixer, snow and noise may appear in the picture when viewing cable TV channels over 37.

Connecting an antenna/cable TV system without a VCR

If your cable company requires you to connect a cable box, make the connection as follows:

Cable or antenna



Cable box



Cable box and cable

■ KV-27S35127V35129V35C29V75MI32S3512V35134V35C33V35135V45135V75 only

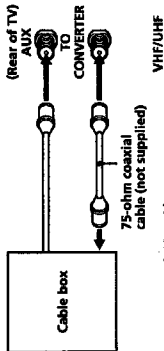

Pay cable TV systems use scrambled or encoded signals requiring a cable box* in addition to the normal cable connection.

* The cable box will be supplied by the cable company.
Note

- You cannot watch the signal through AUX connector as a window picture.

Cable and antenna

■ KV-27S35127V35129V35C29V75MI32S3512V35134V35C33V35135V45135V75 only

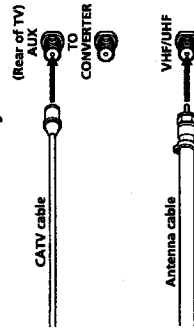

Note

- Do not connect anything to the TO CONVERTER connector in this case.

Connecting an antenna/cable TV system with a VCR

To connect your VCR to the TV, first check the model number of your TV and select the corresponding connection. For details on connection, see the instruction manual of your VCR.

In order to operate PIP, a VCR must be connected to your TV and turned on (KV-27S2527V2529KS25/29KS25C29V65M/32S25/32TW25/2V25 only).

Without a cable box

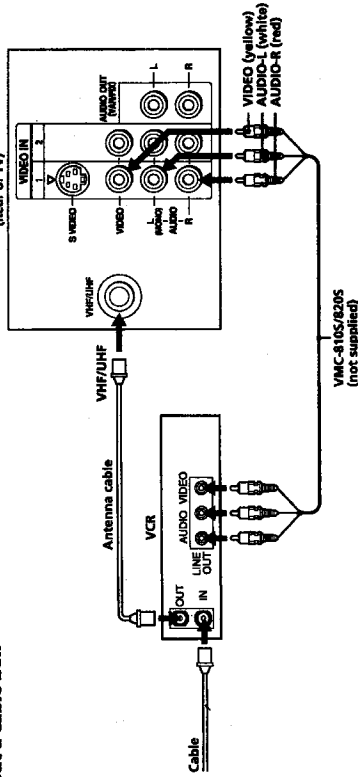

Note

- To connect a monaural VCR, connect the audio output of the VCR to AUDIO-L (mono) of VIDEO 1 IN on the TV.

To an S video equipped VCR without a cable box

If your VCR has an S video output jack, make the following connections.

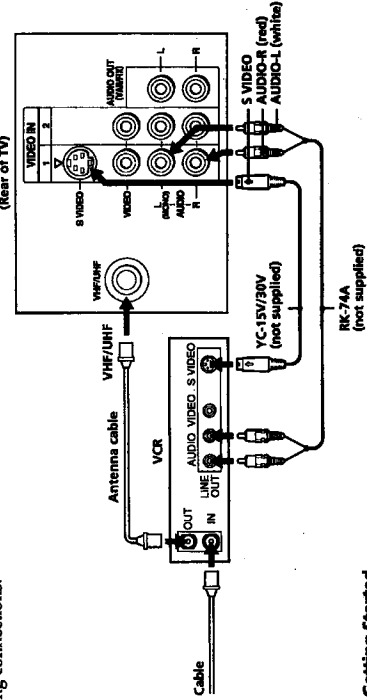

Getting Started | 5 6 | Getting Started

With a cable box

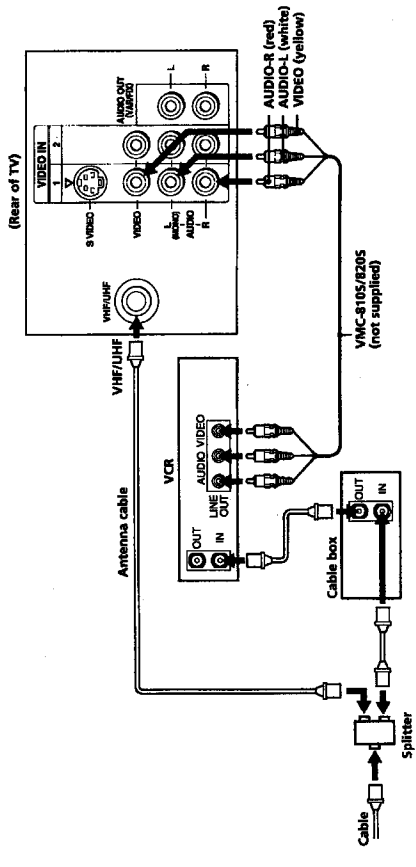

Note
 • To connect a monaural VCR, connect the audio output of the VCR to AUDIO-L (mono) of VIDEO 1 IN on the TV.

To an S video equipped VCR with a cable box

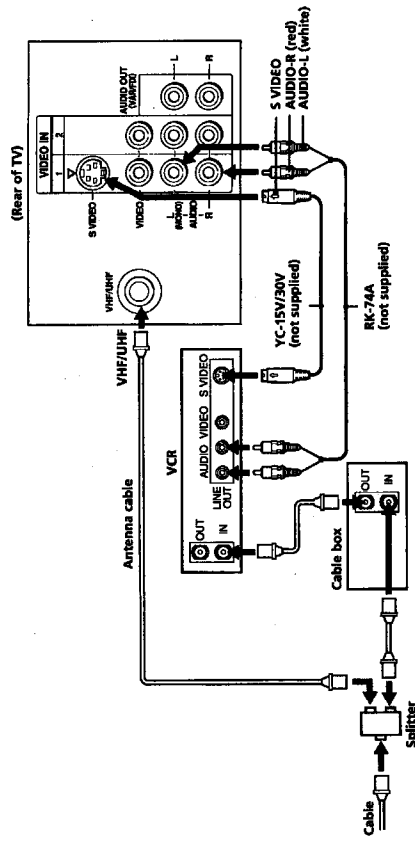

Note
 • Video signals are composed of Y (luminance) and C (chroma) signals. The S connection sends the two signals separately preventing degradation, and gives better picture quality compared to conventional connections.

Connecting a DBS receiver

For connection details, see the instruction manual of the DBS (Digital Broadcasting Satellites) receiver.

To a TV

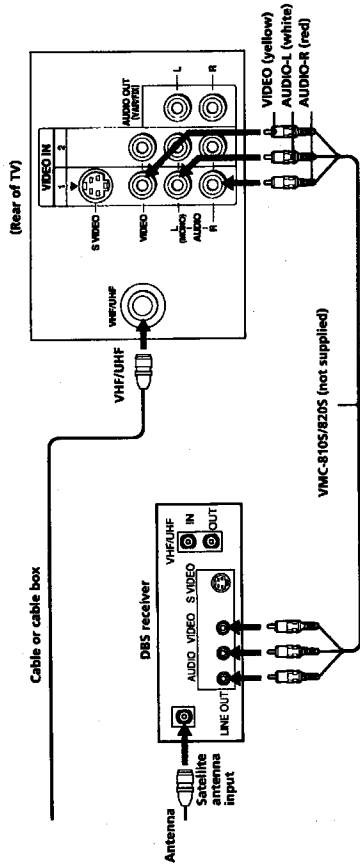

Note
 • You can use the S VIDEO jack or the composite video jack for the video connection.

To a TV and VCR

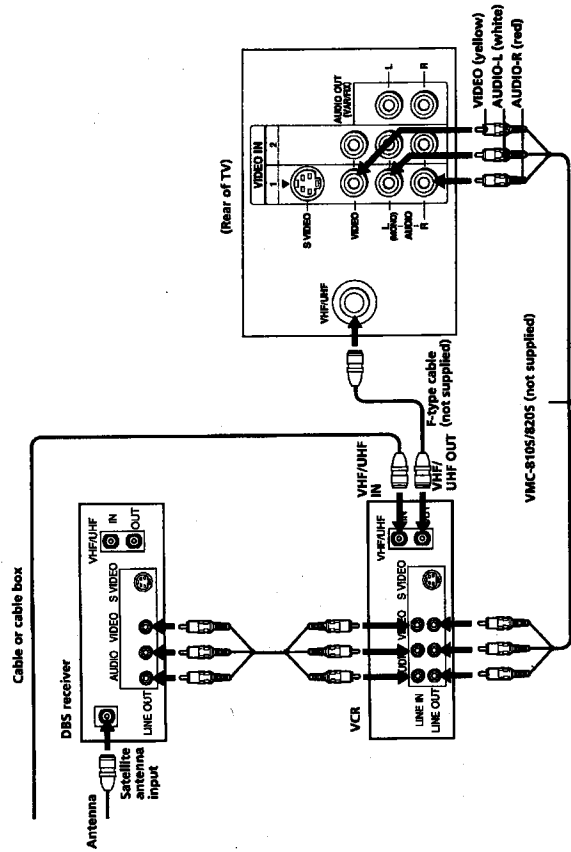

Connecting a camcorder

- KV-27V25/27V35/29V35/32V35/35V35/35V45/35V75 only

This connection is convenient for viewing a camcorder picture.

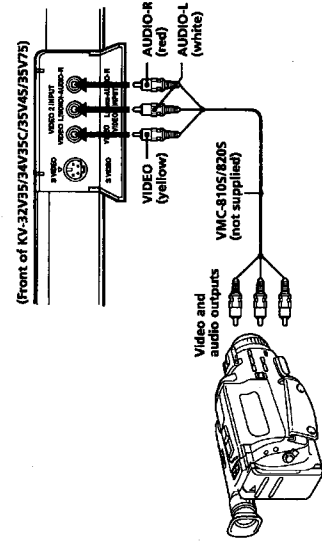

Note

- To connect a monaural camcorder, connect the audio output of the camcorder to AUDIO-L (mono) of VIDEO 2 INPUT on the TV.

Connecting an audio system

When connecting audio equipment, see page 27 for more information.

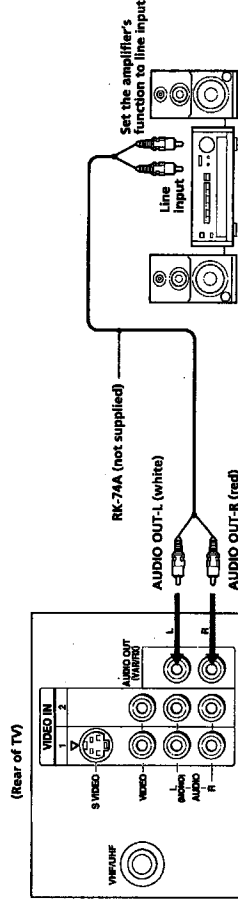

Connecting two VCRs for tape editing using MONITOR OUT

- KV-27V25/27V35/29V35/32V35/35V35/35V45/35V75 only

MONITOR OUT allows you to record a program that is on the screen.

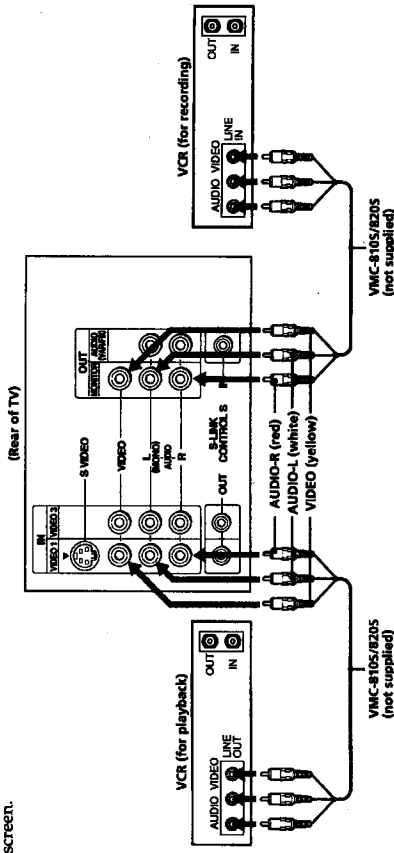

The above type of connection should only be used when you connect from the line input of one VCR, and from the line output of a second VCR.

Notes

- Do not change the input signal while editing through MONITOR OUT; or the output signal will also change.
- You can use the S video jack to connect a VCR for playback and the composite video jack to connect a VCR for recording.

- When connecting a single VCR to the TV, do not connect the MONITOR OUT jacks at the rear of the TV to the VCR's line input, while at the same time connecting from the TV's VIDEO IN jacks to the VCR's line output, as shown below.

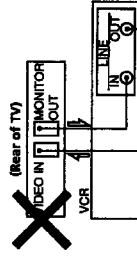

Using the S-Link function

- KV-27V25/27V35/29V35/32V35/35V35/35V45/35V75 only

The S-Link feature allows you to operate the TV and VCR with the S-Link function in the following ways:

- When you press the VCR's play button, the TV's input mode is automatically changed to video, and the VCR starts playing a tape.

- When you press the VCR's stop button, the TV automatically returns to the previous input mode.
- You can turn off the TV and VCR together using the SYSTEM OFF button (see page 35 for details).

Note

- The TV may malfunction if you connect the S-Link cable to the TV without connecting the other end of the cable to the VCR.

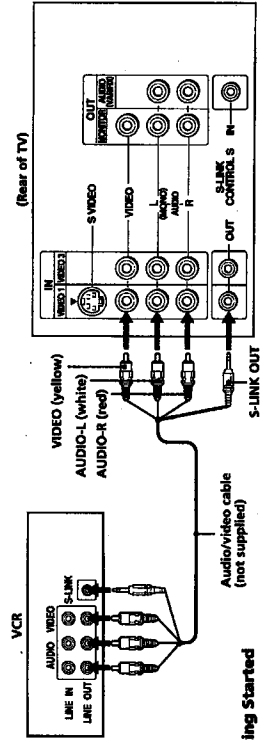

Connecting an AV receiver

Connect an optional AV receiver to the VIDEO 1 IN jacks at the rear of the TV.

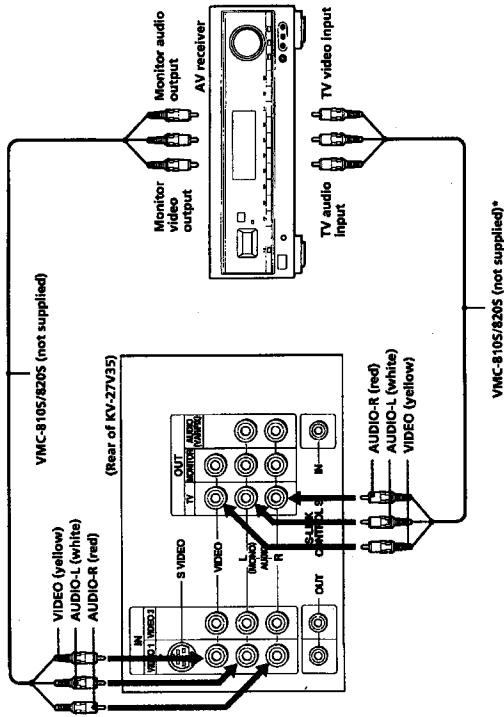

* (KV-27V35/29V35C/29V75M/32V35/34V35C/35V45/35V75 only)

Make this connection if your TV has the TV OUT jacks. When you connect an AV receiver to the TV using the AV receiver's TV input jacks, it is recommended to set VIDEO 1 IN's video label to "RECEIVER" (see page 32 for details).

Step 2: Installing the glass door and adjusting the shelf

KV-32TW2535V75 only

Follow these instructions to install the glass door and adjust the shelf.

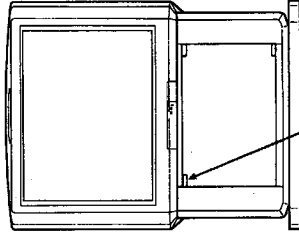

Push here to close.
To open, push again.

Parts List

1	Bottom hinge		1
2	Top hinge		1
3	Screw 4 x 4		4
4	Plate pad		1
5	Plate		1

Installing the glass door

1 Check that the projection of the screw through the hinge allows for proper installation of the hinge to the glass door, and then insert the bottom hinge 1 into the hole located at the bottom, right side of cabinet.

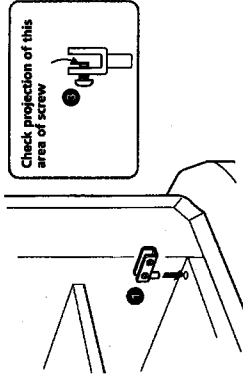

2 Attach the top hinge 2 to the right side of the glass door, tighten the screws snugly, but do not overtighten. Attach the plate pad 3 to the left side and push the plate 4 over the plate pad.

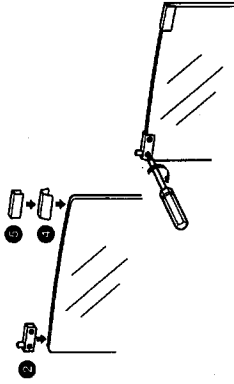

3 Push the top, glass door hinge into the top, right bushing and gently slide the glass door into the bottom hinge. Adjust the glass door until level, and tighten the hinge screws.

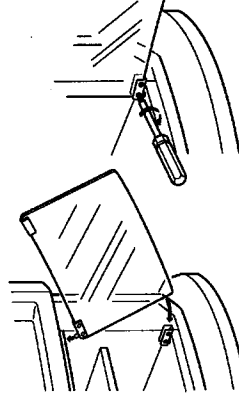

Note

The glass door is made of tempered glass. Although it is more shock-resistant than ordinary glass, tempered glass may shatter if it is dropped or receives a sudden shock.

Adjusting the shelf

- 1 Unlock the four shelf supports with a medium Phillips head screwdriver. Turn the screwdriver 90° to unlock the shelf supports.

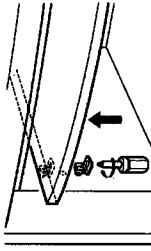

- 2 Gently slide the shelf up and out.

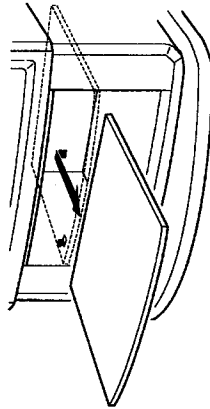

- 3 Insert shelf supports in the appropriate holes. Slide shelf in, align the shelf grooves with the shelf supports, and slide the shelf down.

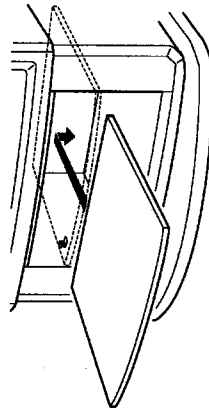

Step 3: Setting up the remote commander

Inserting batteries

Insert two size AA (R6) batteries (supplied) by matching the + and - on the battery to the diagram inside the battery compartment.

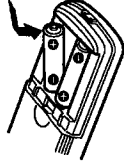
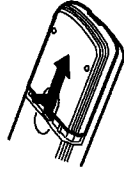

Notes

- Under normal conditions, batteries will last up to six months. If the remote commander does not operate properly or the indicators of the buttons on the remote commander do not light up, the batteries may be worn out. When replacing batteries, replace both of them with new ones.
- Do not mix old batteries with new ones or mix different types of batteries together.
- If the electrolyte inside the battery should leak, wipe the contaminated area of the battery compartment with a cloth and replace the old batteries with new ones. To prevent the electrolyte from leaking, remove the batteries when you don't plan to use the remote commander for a long period of time.
- Do not handle the remote commander roughly. Do not drop it, step on it or let it get wet.
- Do not place the remote commander in direct sunlight, near a heater, or where the humidity is high.

Getting to know buttons on the remote commander

Names of buttons on the remote commander are indicated in different colors to represent the available functions.

Button color

Transparent TV/VCR/Cable box operation buttons. Press the appropriate function button first to change the remote commander's function.
Green Buttons relevant to power operations.

Label color

White TV/VCR/Cable box operation buttons.
Yellow PIP operation buttons.
Blue DBS operation buttons.

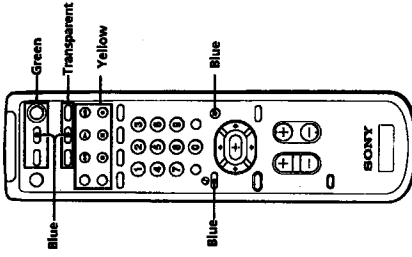

Step 4: Setting up the TV automatically (AUTO SET UP)

You can set up your TV easily by using the AUTO SET UP feature. It presets all the receivable channels. To set up the TV manually, see "Setting cable TV on or off" (page 17) and "Presetting channels" (page 17).

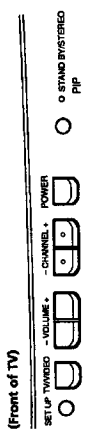

For KV-27V35/29V35C/29V75M/32V35/34V35C/35V45/35V75, the control buttons are located on the top of the TV.

Before you start using AUTO SET UP, be sure to connect the antenna or cable to the TV (see page 5).

1 Press POWER to turn on the TV.

The AUTO SET UP screen appears.

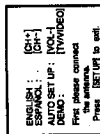

Note

- The AUTO SET UP screen appears whenever you press the POWER button if you do not execute AUTO PROGRAM.

2 (Except Canadian models) Press CHANNEL + to select English screens or CHANNEL - to select Spanish screens.



3 Press VOLUME -.

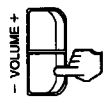

"AUTO PROGRAM" appears on the screen and the TV starts scanning and presetting channels automatically. When all the receivable channels are stored, "AUTO PROGRAM" disappears and the lowest numbered channel is displayed. If the TV receives cable TV channels, CABLE is set on automatically.

To perform AUTO SET UP again

- Press SET UP on the TV.
- (Except Canadian models) Press CHANNEL + or CHANNEL - to select the language.
- Press VOLUME -.
- The picture and sound settings will be set to the factory preset conditions.
- Press CHANNEL +.
- "AUTO PROGRAM" appears on the screen and the TV starts scanning and presetting channels.
- Press CHANNEL - to exit the AUTO SET UP menu.

To exit AUTO PROGRAM

Press any button.

Notes

- If the TV is set to a video input, you cannot execute AUTO SET UP. Press TV (black button) so that a channel number appears.
- Using the AUX connector, press TV (black button) first and make sure that "AUX" is displayed beside the channel number on the screen. Then follow the procedure above to perform AUTO SET UP. (KV-27V35/27V35/29V35C/29V75M/32V35/32V35/34V35C/35V45/35V75 only)

To browse the main functions (DEMO)

Press TV/VIDEO on the TV in step 3. The functions and menus are displayed one by one.

To exit DEMO

Press any button.

Erasing or adding channels

After AUTO SET UP, you can erase unnecessary channels or add the channels you want. Preset channels during the day rather than late at night, when some channels may not be broadcasting.

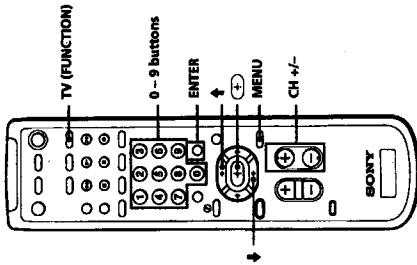

1 Press TV (FUNCTION).

The TV FUNCTION screen appears.



2 Press MENU.

The main menu appears.



3 Press + or - to select, and press ENTER.

The SET UP menu appears.

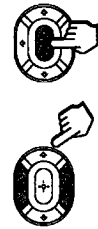

4 Press + or - to select CHANNEL ERASE/ADD, and press ENTER.

The CHANNEL ERASE/ADD menu appears.

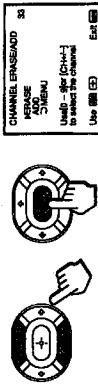

5 Erase and/or add channels:

- To erase an unwanted channel: (1) Make sure the cursor (▶) is beside ERASE. (2) Press CH +/- or the 0-9 buttons to select the channel you want to erase, and press ENTER.

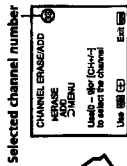

(3) Press ENTER.

The "✓" indication appears beside the channel number, showing that the channel is erased from the preset memory.



To add a channel that you want

- Press + or - to move the cursor (▶) to ADD.
- Press the 0-9 buttons to select the channel you want to add, and press ENTER.

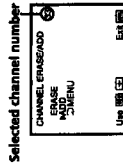

(3) Press ENTER.

The "✓" indication appears beside the channel number, showing that the channel is added to the preset memory.



6 To erase and/or add other channels, repeat step 5.

7 Press MENU to return to the original screen.

MENU



Notes

- If you erase or add a VHF or UHF channel, the cable TV channel with the same number is also erased or added, and vice versa.
- Erasing and adding channels is also available for the AUX input. (KV-27/S35/27V35/29V35C/29V75M/32S35/32V35/34V35C/35V35/35V45/35V75 only)

Setting cable TV on or off

If you have connected the TV to a cable TV system, set CABLE to ON (the factory setting). If not, set CABLE to OFF. You do not have to do this procedure if you execute AUTO SET UP (page 15). Do this procedure only when you want to set it manually.

- 1 Press MENU.
- 2 Press \uparrow or \downarrow to select **CABLE**, and press \odot .
- 3 Set CABLE to ON or OFF:
(1) Press \uparrow or \downarrow to move the cursor (\blacktriangleright) to CABLE, and press \odot .
(2) Press \uparrow or \downarrow to select ON or OFF, and press \odot .

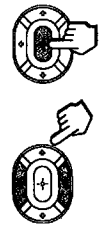

4 Press MENU to return to the original screen.

Note

- If CABLE appears in gray, the TV is set to a video input and you cannot select CABLE. Press TV (black button) so that a channel number appears.

Presetting channels

You can preset TV channels easily by using the AUTO PROGRAM feature. You do not have to do this procedure if you execute AUTO SET UP (page 15). Do this procedure only when you want to set it manually.

- 1 Press MENU.
- 2 Press \uparrow or \downarrow to select **AUTO PROGRAM**, and press \odot .
- 3 Press \uparrow or \downarrow to select **AUTO PROGRAM**, and press \odot .



"AUTO PROGRAM" appears on the screen and the TV starts scanning and presetting channels automatically. When all the receivable channels are stored, "AUTO PROGRAM" disappears and the lowest numbered channel is displayed.

4 Press MENU to return to the original screen.

To exit AUTO PROGRAM

Press any button.

Notes

- If the AUTO PROGRAM menu appears in gray, the TV is set to a video input and you cannot select AUTO PROGRAM. Press TV (black) so that a channel number appears.
- Presetting channels is also available for the AUX input. (KV-27/S35/27V35/29V35C/29V75M/32S35/32V35/34V35C/35V35/35V45/35V75 only)

Changing the menu language

■ Except Canadian models

If you prefer Spanish to English, you can change the menu language. You do not have to do this procedure if you select the language during AUTO SET UP (page 15).

- 1 Press MENU.
- 2 Press \uparrow or \downarrow to select **LANGUAGE**, and press \odot .
- 3 Press \uparrow or \downarrow to select **LANGUAGE**, and press \odot .

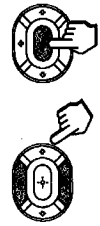
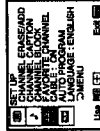

4 Press \uparrow or \downarrow to select your favorite language, "ENGLISH" or "ESPAÑOL," and press \odot .

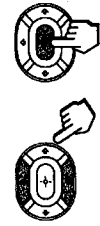

5 Press MENU to return to the original screen.

Note

- Certain parts of the Spanish menus remain in English.

Adjusting the tilt of the picture (TILT CORRECTION)

■ KV-35V35/35V45/35V75 only

You can adjust the tilt of the picture if it is not aligned with the TV screen. Misalignment may be caused by the direction of the earth's magnetic fields in relation to the position of the TV.

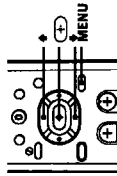

- 1 Press MENU.
- 2 Press \uparrow or \downarrow to select **TILT CORRECTION**, and press \odot .
- 3 Press \uparrow or \downarrow to select **TILT CORRECTION**, and press \odot .

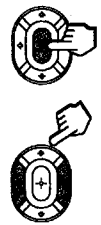

4 Press \uparrow or \downarrow to adjust the tilt between +5 and -5.

5 Press MENU to return to the original screen.

Notes

- If your house is located near a high-voltage cable or is of reinforced concrete, you may not be able to correct the tilt of the picture properly. Consult your nearest Sony dealer.
- If there are large speakers near the TV, the tilt of the picture cannot be corrected properly. Place the TV away from the speakers.

Watching the TV

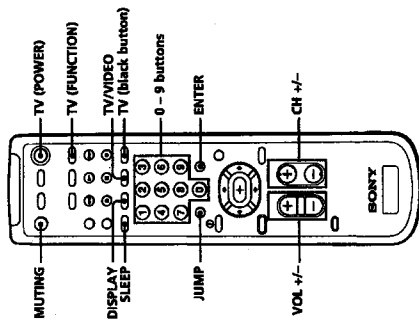

1 Press TV (POWER) to turn on the TV.



If "VIDEO" appears on the screen, press TV (black button) so that a channel number appears.

2 Press TV (FUNCTION).

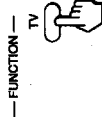

Once you press TV (FUNCTION), the TV function is set unless another function button is pressed.

3 Select the channel you want:

To select a channel directly
Press the 0 - 9 buttons, and press ENTER.
To scan through channels
Press CH +/- until the channel you want appears.



The channel can also be selected without pressing ENTER.

4 Press VOL +/- to adjust the volume.

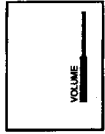

Switching quickly between two channels

You can use the JUMP button to switch or "jump" back and forth between two channels.

Press JUMP.



Pressing JUMP again switches back the channel.

Note

- You cannot jump to channels you scanned through using the CH +/- buttons.

Muting the sound

Press MUTING.

"MUTING" appears on the screen.



To restore the sound, press MUTING again, or press VOL +.

Displaying on-screen information

Press DISPLAY repeatedly until the desired display appears.

Each time you press DISPLAY, the display changes as follows:

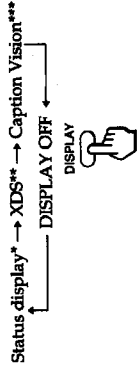

* Channel number, the current time (only for available models), channel caption (if set), and MTS mode (if SAP is selected) are displayed. SAP indication disappears after three seconds.

** Some programs are broadcast with XDS (Extended Data Service) which shows a network name, program name, program type, program length, call letters, and time of the show. When you select XDS with the DISPLAY button, this information will be displayed on the screen if the broadcaster offers this service.

*** Some programs are broadcast with Caption Vision. When you select Caption Vision with the DISPLAY button, Caption Vision will be displayed on the screen if the broadcaster offers this service. (See page 33 for selecting Caption Vision.)

To cancel the display, press DISPLAY repeatedly until "DISPLAY OFF" appears. "DISPLAY OFF" goes off after three seconds.

Setting the Sleep Timer

The TV stays on for the length of time you specify and then shuts off automatically.

Press SLEEP repeatedly until the time (minutes) you want appears.

Each time you press SLEEP, the time changes as follows:

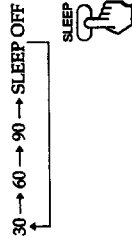

To cancel the Sleep Timer, press SLEEP repeatedly until "SLEEP OFF" appears, or turn off the TV.

Watching a video input picture

Press TV/VIDEO repeatedly until the desired video input appears.

Each time you press TV/VIDEO, the display changes as follows:

■ KV-2752/2753/2965/2965Z/2965ZS/32W25 only



■ KV-27V2/27V3/29V3/29V3C/29V3CZ/29V3CZS/29V3CZS2/29V3CZS2S/32V3/32V3C/32V3CZ/32V3CZS/32V3CZS2/32V3CZS2S only

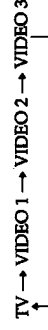

To return to the TV picture, press TV (black button) so that a channel number appears.

Changing the VHF/UHF input to the AUX input

■ KV-2753/27V3/29V3/29V3C/29V3CZ/29V3CZS/32V3/32V3C/32V3CZ/32V3CZS/32V3CZS2/32V3CZS2S only

Press TV (black button).



Pressing TV (black button) again switches back to the previous input.

Watching two programs at a time — PIP

The Picture-in-Picture (PIP) feature allows you to watch both the main picture and a window picture simultaneously.

For KV-27S25/27V25/29RS25/29RS25C/29V65M/32S25/32TW25/32V25, your TV must be connected to a VCR to enjoy this feature. See "Connecting an antenna/cable TV system with a VCR" (page 6) for connections. In order to operate PIP, your VCR must be turned on.

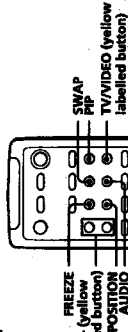

Use the yellow labelled buttons for PIP operations.

Displaying a window picture

Press PIP.

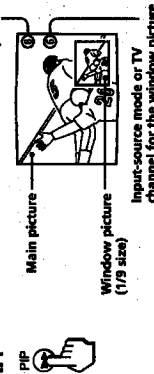

Press PIP again to display a smaller window picture.

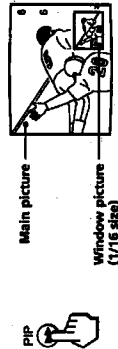

To remove the window picture, press PIP again.

Note
• The window picture may be affected by the condition of the main picture.

Changing the window picture input mode

Press TV/VIDEO (yellow labelled button) to select the input mode.

Each time you press TV/VIDEO (yellow labelled button), "TV," "VIDEO 1," "VIDEO 2," and "VIDEO 3 (KV-27V25/27V35/29V35C/29V65M/29V75M/32V25/32V35/34V35C/35V35/35V45/35V75 only)" appear in sequence.



A window picture will appear in the same input mode as the last time you used PIP.

Note

- If you use one of the connections from page 6, your PIP input source is a VCR. If you use one of the connections from page 7, your PIP input source is a VCR or cable box.

Listening to the sound of the window picture

Press AUDIO.

The J display appears next to the PIP channel number for a few seconds, indicating that the window picture sound is being received.

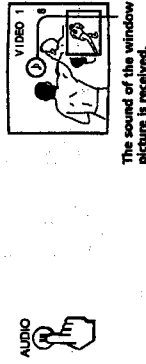

The sound of the window picture is received.

To restore the main picture sound, press AUDIO again. The J display moves to the main picture channel number.

Changing TV channels in the window picture

Press CH +/- (yellow labelled button).

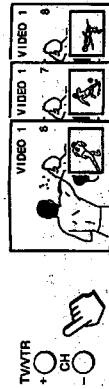

Changing the position of the window picture

Press POSITION. Each time you press POSITION, the window picture will move counterclockwise on the screen.



Freezing the window picture

This feature is useful when you want to write down a recipe from a cooking program, a displayed address, or a phone number for example.

Press FREEZE.



To restore the normal screen, press FREEZE again.

Swapping the main and window pictures

Press SWAP.

Each time you press SWAP, the images from the main and window pictures switch places along with the sound.

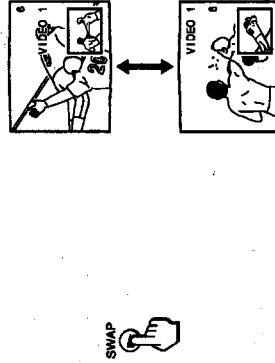

Note

- The channels being received through the AUX jack cannot be displayed as a window picture. (KV-27S35/27V35/29V35C/29V75M/32S35/32V35/34V35C/35V35/35V45/35V75 only)

Adjusting the picture (VIDEO)

When watching TV programs, you can adjust the picture to suit your taste. You can adjust the picture of video input(s) as well. These settings are stored separately from those for the TV picture.

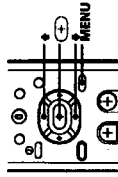

1 Press MENU.

2 Press \uparrow or \downarrow to select \square , and press \rightarrow .



3 Select the item you want to adjust.

For example:
(1) To adjust the brightness, press \uparrow or \downarrow to move the cursor (\blacktriangleright) to BRIGHTNESS.

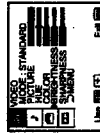

(2) Press \rightarrow .



Selecting the video mode (VIDEO)

- 4 Adjust the selected item:**
(1) Press \leftarrow or \rightarrow to adjust the item.



- (2) Press \leftarrow .

The new setting appears in the VIDEO menu.



For details on each item, see "Description of adjustable items" below.

- 5 To adjust other items, repeat steps 3 and 4.**
6 Press MENU to return to the original screen.

Description of adjustable items

Item	Press \leftarrow to	Press \rightarrow to
PICTURE	Decrease picture contrast and give soft color.	Increase picture contrast and give vivid color.
HUE	Make picture tones become purplish.	Make picture tones become greenish.
COLOR	Decrease color intensity.	Increase color intensity.
BRIGHTNESS	Darken the picture.	Brighten the picture.
SHARPNESS	Soften the picture.	Sharpen the picture.

To restore the factory settings

Press RESET while the VIDEO menu is displayed. All the settings are restored to the factory settings.

The video mode feature allows you to choose three different modes of picture settings. Choose the one that best suits the type of program that you want to watch.

- 1 Press MENU.**
- 2 Press \leftarrow or \rightarrow to select \square , and press \leftarrow .**
- 3 Press \leftarrow or \rightarrow to select MODE, and press \leftarrow .**
- 4 Press \leftarrow or \rightarrow to select STANDARD, MOVIE, or SPORTS mode, and press \leftarrow .**

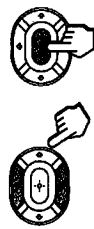

Choose	To
STANDARD	Receive a standard picture.
MOVIE	Receive a finely detailed picture.
SPORTS	Receive a vivid, bright picture.

- 5 Press MENU to return to the original screen.**

Note
• The settings for these modes can be adjusted in the VIDEO menu.

Adjusting picture brightness automatically (LIGHTSENSOR)

■ KV-27V2527V3529V35C29V65SM29V75SM32V25/32V3534V35C35V35S35V4535V75 only

The LightSensor feature adjusts the brightness of the picture automatically according to the ambient brightness.

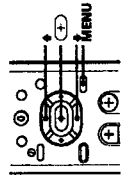

- 1 Press MENU.**
- 2 Press \leftarrow or \rightarrow to select \square , and press \leftarrow .**
- 3 Press \leftarrow or \rightarrow to select LIGHTSENSOR, and press \leftarrow .**

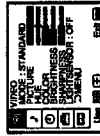

- 4 Press \leftarrow or \rightarrow to select ON or OFF, and press \leftarrow .**



- 5 Press MENU to return to the original screen.**

Note

- The LightSensor function may malfunction if you stand or place objects in front of the TV.

Adjusting the sound (AUDIO)

You can adjust the TV sound to suit your taste. You can adjust the sound of the video input(s) as well. These settings are stored separately from those for the TV sound.

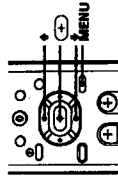

- 1 Press MENU.**
- 2 Press \leftarrow or \rightarrow to select \square , and press \leftarrow .**



- 3 Select the item you want to adjust.**

For example:
(1) To adjust bass, press \leftarrow or \rightarrow to move the cursor (\rightarrow) to BASS.

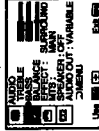

- (2) Press \leftarrow .

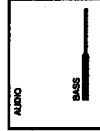

Using audio effect (EFFECT)

- 4 Adjust the selected item:**
 (1) Press \blacktriangle or \blacktriangledown to adjust the item.

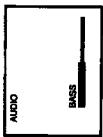

- (2) Press \odot .
 The new setting appears in the AUDIO menu.

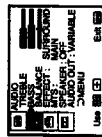

For details on each item, see "Description of adjustable items" below.

- 5 To adjust other items, repeat steps 3 and 4.**
6 Press MENU to return to the original screen.

Description of adjustable items

Item	Press \blacktriangle or \blacktriangledown to	Press \blacktriangle or \blacktriangledown to
TREBLE	Decrease the treble response.	Increase the treble response.
BASS	Decrease the bass response.	Increase the bass response.
BALANCE	Emphasize the left speaker's volume.	Emphasize the right speaker's volume.

To restore the factory settings

Press RESET while the AUDIO menu is displayed.

Note

- When SPEAKER (page 27) is OFF and AUDIO OUT (page 27) is in the FIXED condition, the volume, TREBLE, BASS, and BALANCE cannot be adjusted.

Using the menu to set audio effect

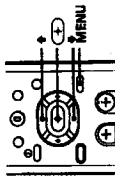

- 1 Press MENU.**
2 Press \blacktriangle or \blacktriangledown to select J, and press \odot .
3 Press \blacktriangle or \blacktriangledown to select EFFECT, and press \odot .

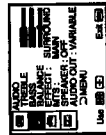

- 4 Press \blacktriangle or \blacktriangledown to select the audio effect mode, and press \odot .**



- 5 Press MENU to return to the original screen.**

Selecting stereo or bilingual programs (MTS)

The Multichannel TV Sound (MTS) feature allows you to enjoy stereo sound or Second Audio Programs (SAP) of your choice. The initial setting is stereo sound (MAIN).

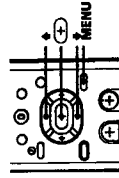

- 1 Press MENU.**
2 Press \blacktriangle or \blacktriangledown to select J, and press \odot .
3 Press \blacktriangle or \blacktriangledown to select MTS, and press \odot .



- 4 Press \blacktriangle or \blacktriangledown to select MAIN, SAP, or MONO, and press \odot .**

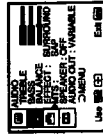

Choose To

MAIN	Listen to stereo sound. The STEREO indicator on the TV lights up when a stereo broadcast is received.
SAP	Listen to bilingual programs. There is no sound when the SAP signal is not broadcasting.
MONO	Listen to monaural sound. Reduce noise during stereo broadcasts.

- 5 Press MENU to return to the original screen.**

Note

- Stereo and SAP sounds are subject to program sources.

Using audio effect (EFFECT)

- 4 Adjust the selected item:**
 (1) Press \blacktriangle or \blacktriangledown to adjust the item.

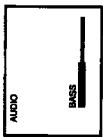

- (2) Press \odot .
 The new setting appears in the AUDIO menu.



For details on each item, see "Description of adjustable items" below.

- 5 To adjust other items, repeat steps 3 and 4.**
6 Press MENU to return to the original screen.

Description of adjustable items

Item	Press \blacktriangle or \blacktriangledown to	Press \blacktriangle or \blacktriangledown to
TREBLE	Decrease the treble response.	Increase the treble response.
BASS	Decrease the bass response.	Increase the bass response.
BALANCE	Emphasize the left speaker's volume.	Emphasize the right speaker's volume.

To restore the factory settings

Press RESET while the AUDIO menu is displayed.

Note

- When SPEAKER (page 27) is OFF and AUDIO OUT (page 27) is in the FIXED condition, the volume, TREBLE, BASS, and BALANCE cannot be adjusted.

Using the menu to set audio effect

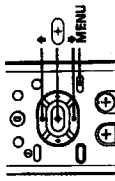

- 1 Press MENU.**
2 Press \blacktriangle or \blacktriangledown to select J, and press \odot .
3 Press \blacktriangle or \blacktriangledown to select EFFECT, and press \odot .

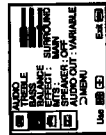

- 4 Press \blacktriangle or \blacktriangledown to select the audio effect mode, and press \odot .**



- 5 Press MENU to return to the original screen.**

Using audio effect (EFFECT)

- 4 Adjust the selected item:**
 (1) Press \blacktriangle or \blacktriangledown to adjust the item.

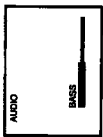

- (2) Press \odot .
 The new setting appears in the AUDIO menu.

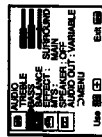

For details on each item, see "Description of adjustable items" below.

- 5 To adjust other items, repeat steps 3 and 4.**
6 Press MENU to return to the original screen.

Description of adjustable items

Item	Press \blacktriangle or \blacktriangledown to	Press \blacktriangle or \blacktriangledown to
TREBLE	Decrease the treble response.	Increase the treble response.
BASS	Decrease the bass response.	Increase the bass response.
BALANCE	Emphasize the left speaker's volume.	Emphasize the right speaker's volume.

To restore the factory settings

Press RESET while the AUDIO menu is displayed.

Note

- When SPEAKER (page 27) is OFF and AUDIO OUT (page 27) is in the FIXED condition, the volume, TREBLE, BASS, and BALANCE cannot be adjusted.

Setting the speaker switch (SPEAKER)

You may switch off the TV speakers when, for example, you want to listen to the sound through a stereo system.

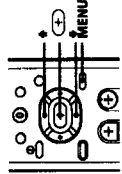

- 1 Press MENU.
- 2 Press \uparrow or \downarrow to select **S**, and press \rightarrow .
- 3 Press \uparrow or \downarrow to select **SPEAKER**, and press \rightarrow .

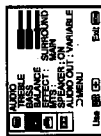

- 4 Press \uparrow or \downarrow to select **ON** or **OFF**, and press \rightarrow .

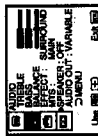

- 5 Press MENU to return to the original screen.

Setting audio out (AUDIO OUT)

You can change AUDIO OUT to VARIABLE or FIXED when SPEAKER is set to OFF. AUDIO OUT is variable when SPEAKER is set to ON.

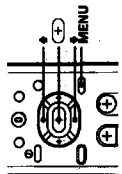

- 1 Press MENU.
- 2 Press \uparrow or \downarrow to select **A**, and press \rightarrow .
- 3 Press \uparrow or \downarrow to select **AUDIO OUT**, and press \rightarrow .

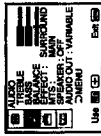

- 4 Press \uparrow or \downarrow to select **VARIABLE** or **FIXED**, and press \rightarrow .

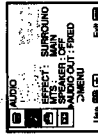

VARIABLE: Sound output varied according to the TV settings. You can adjust the volume, bass, treble, and balance.

FIXED: Sound output is always fixed to a certain level. The volume, bass, treble, and balance are also fixed to the factory settings.

- 5 Press MENU to return to the original screen.

Note

- If AUDIO OUT appears in gray, set SPEAKER to OFF.

Setting daylight saving time (DAYLIGHT SAVING)

KV-27V25I27V25I29V35C29V65M29V75M32V25I 32V25I34V35C35V35I35V45I35V75 only

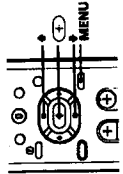

- 1 Press MENU.
- 2 Press \uparrow or \downarrow to select **D**, and press \rightarrow .
- 3 Press \uparrow or \downarrow to select **DAYLIGHT SAVING**, and press \rightarrow .



- 4 Press \uparrow or \downarrow to select **YES** or **NO**, and press \rightarrow .



Choose To
YES Set for daylight saving start.
 The current time automatically moves one hour ahead.
NO Set for daylight saving end.

- 5 Press MENU to return to the original screen.

Setting the clock (CURRENT TIME SET)

KV-27V25I27V25I29V35C29V65M29V75M32V25I 32V25I34V35C35V35I35V45I35V75 only

Setting the clock enables you to turn the TV on and off with the timer. Make sure to set daylight saving time first.

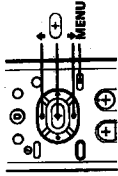

- 1 Press MENU.
- 2 Press \uparrow or \downarrow to select **C**, and press \rightarrow .
- 3 Press \uparrow or \downarrow to select **CURRENT TIME SET**, and press \rightarrow .



- 4 Make sure the cursor (**P**) is to the left of "--:-- AM," and press \leftarrow .

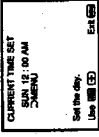

- 5 Set the current time.
 - (1) Press \uparrow or \downarrow to set the day, and press \rightarrow .

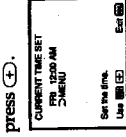

- (2) Set the hour and minutes in the same way as in step (1). When you press \rightarrow after setting the minutes, the clock starts.

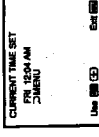

- 6 Press MENU to return to the original screen.

Blocking out a channel (CHANNEL BLOCK)

The channel block feature allows you to prevent children from watching unsuitable programs. You can block out two channels.

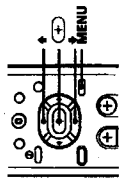

- 1 Press **MENU**.
- 2 Press **1** or **2** to select **CHANNEL BLOCK**, and press **ENTER**.
- 3 Press **1** or **2** to select **CHANNEL BLOCK**, and press **ENTER**.
- 4 Press **1** or **2** to select **1** or **2**, and press **ENTER**.
- 5 Press **1** or **2** to select the channel which you want to block out, and press **ENTER**.

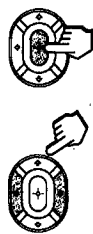
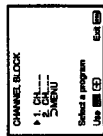

- 6 Press **MENU** to return to the original screen. When you select the blocked channel "BLOCKED" appears on the screen.

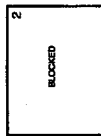

To cancel a **CHANNEL BLOCK** setting In step 4 or 5, press **RESET**.

Note

- Once you use **CHANNEL BLOCK**, Caption Vision and XDS of the blocked channel and the selected channel output from TV OUT/MONITOR OUT are also blocked out.

Setting your favorite channels (FAVORITE CHANNEL)

The favorite channel feature allows your TV to memorize your favorite channels easily. If you set to **AUTO**, the last five channels you selected with the 0-9 buttons are automatically set as your favorite channels. If you want to input your own selection of channels, set to **MANUAL**.

Setting your favorite channels

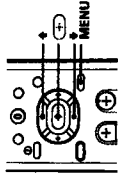

- 1 Press **MENU**.
- 2 Press **1** or **2** to select **FAVORITE CHANNEL**, and press **ENTER**.
- 3 Press **1** or **2** to select **FAVORITE CHANNEL**, and press **ENTER**.
- 4 Press **1** or **2** to select **AUTO** or **MANUAL**, and press **ENTER**.

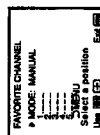
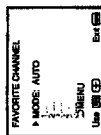

If you select **AUTO**, skip steps 5 and 6. The last five channels you selected with the 0-9 buttons are automatically set as your favorite channels.

If you select **MANUAL**, the favorite channel numbers become white, indicating that favorite channels can be entered.

(continued)

- 5 Press **1** or **2** to select a favorite channel number, and press **ENTER**.

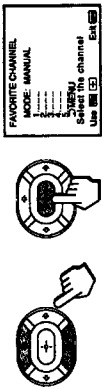

- 6 Press **1** or **2** to select the channel that you want to set as your favorite channel, and press **ENTER**.

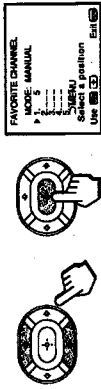

- 7 Press **MENU** to return to the original screen.

Notes

- If the **FAVORITE CHANNEL** menu appears in gray, the TV is set to a video input and you cannot select **FAVORITE CHANNEL**.
- If more than 90 seconds elapse after you press another button, the menu disappears automatically.
- The favorite channel feature is not available for the **AUX** input.

Selecting your favorite channel

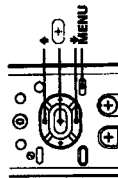

- 1 Press **ENTER**. The **FAVORITE CHANNEL** menu appears.



- 2 Press **1** or **2** to select the favorite channel you want to watch, and press **ENTER**.

The selected channel appears on the screen.



To cancel the **FAVORITE CHANNEL** menu Press **1** or **2** to select "Exit," and press **ENTER**.

Setting video labels (VIDEO LABEL)

- KV-27V25I27V35I29V35C129V65SM129V75MI32I2V25I 32V35I34V35C135V35I35V45I35V45I35V75** only

The video label feature allows you to label each input mode so that you can easily identify the connected equipment. For example, you can label **VIDEO 1 IN** as **VHS**.

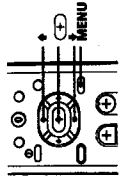

- 1 Press **MENU**.
- 2 Press **1** or **2** to select **VIDEO LABEL**, and press **ENTER**.
- 3 Press **1** or **2** to select **VIDEO LABEL**, and press **ENTER**.

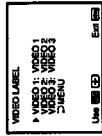

- 4 Press **1** or **2** to select the input mode you want to label, and press **ENTER**.

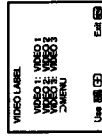

5 Press **+** or **+** to select the label, and press **ENTER**.



Each time you press **+** or **-**, the label changes as follows:

- VIDEO 1**
VIDEO 1 → VHS → 8 mm → BETA → LD → S VIDEO → RECEIVER* → DBS → GAME
- VIDEO 2**
VIDEO 2 → VHS → 8 mm → BETA → LD → RECEIVER* → DBS → GAME → S VIDEO**
- VIDEO 3**
VIDEO 3 → VHS → 8 mm → BETA → LD → RECEIVER* → DBS → GAME

* KV-27V35/29V35C/29V75M/32V35/34V35C/35V45/35V75 only

** KV-32V35/34V35C/35V45/35V75 only
When you connect an AV receiver to the TV using the AV receiver's TV input jacks, it is recommended to set the label to RECEIVER. When RECEIVER is selected, TV channels can be selected while the video input mode is fixed. (See page 11 for the connection.)

6 Repeat steps 4 and 5 to label other input modes.

- Note**
- If more than 90 seconds elapse before you press another button, the menu disappears automatically.

Setting Caption Vision (CAPTION VISION)

Some programs are broadcast with Caption Vision. To display Caption Vision, select either CC1, CC2, CC3, CC4, TEXT1, TEXT2, TEXT3, or TEXT4 from the menu. CC1, CC2, CC3, or CC4 shows you a caption, that is a printed version of the dialogue or sound effects of a program. (The mode should be set to CC1 for most programs.) TEXT1, TEXT2, TEXT3, or TEXT4 shows you text, that is information presented using either half or the whole screen. It is not usually related to the program.

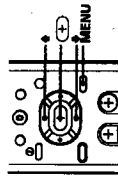

- 1 Press **MENU**.
- 2 Press **+** or **-** to select **TEXT**, and press **ENTER**.
- 3 Press **+** or **-** to select the caption type, and press **ENTER**.

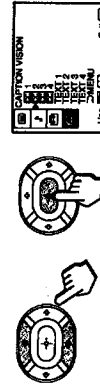
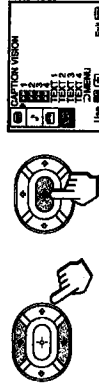

4 Press **MENU** to return to the original screen.

To display Caption Vision
Press **DISPLAY**. (See page 20 for details.)

Notes

- Poor reception of TV programs can cause errors in Caption Vision and XDS.
- Captions may appear with a white box or other errors instead of a certain word.
- XDS, Caption Vision, and the status display cannot be used at the same time.
- For details on XDS, see page 20.

Operating video equipment

You can use the supplied remote commander to operate Sony or non-Sony video equipment that has an infrared remote sensor. For this operation, set the manufacturer's code number.

Setting the manufacturer's code

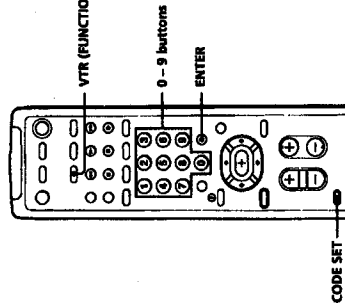

Press the **CODE SET**, **VTR (FUNCTION)**, and **0-9** buttons to enter the manufacturer's code number (see the chart), then press **ENTER**. For example, to operate a Sony 8 mm VCR, press **CODE SET**, **VTR (FUNCTION)**, **3**, **0**, **2**, and **ENTER**.

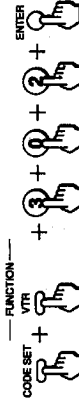

VCR manufacturer code numbers

Manufacturer	Code number
Sony	301, 302, 303
Aiwa	338
Audio Dynamic	314, 337
Bell & Howell (M. Wards)	330, 343
Brosnic	319
Canon	309, 308
Citizen	332
Craig	315, 302, 332
Curtis Mathis	304, 338, 309
Daewoo	341, 312, 309
DBX	314, 336, 337
Dimensia	304
Emerson	319, 320, 316, 317, 318
Fisher	330, 334, 335, 333
Funai	338
General Electric	329, 304, 309
Goldstar	332
Hitachi	306, 304, 305
Instant Replay	309, 308
JC Penny	309, 305, 304, 330, 314, 336, 337
JVC	314, 336, 337
Kenwood	314, 336, 332, 337
LXI (Sears)	332, 305, 333, 334, 330, 335
Magnavox	308, 309
Marantz	314, 336, 337
Marta	332
Memorex	309, 335
Minolta	305, 304
Mitsubishi/MGA	323, 324, 325, 326
Multitech	325, 338, 321
NBC	314, 336, 337
NEC	309, 308
Olympic	308, 309, 306, 307
Panasonic	305, 304
Pentax	308, 309
Philco	308, 309
Philips	308, 309
Pioneer	308
Quasar	308, 309
RCA/PROSCAN	304, 305, 308, 309, 311, 312, 313
Realistic	309, 330, 328, 335, 324, 338
Sansui	314
Singer	315
Samsung	322, 313, 321
Sanyo	330, 335
Scott	312, 313, 321, 335, 323, 324, 325, 326
Sharp	327, 328
Shinbom	315
Signature 2000 (M. Wards)	338, 327
Sylvania	308, 309, 338
Symphonic	338
Tashiro	332
Tatung	314, 336, 337
Teac	314, 336, 338, 337
Technics	309, 308
Toshiba	312, 311
Wards	327, 328, 335, 331, 332
Yamaha	330, 314, 336, 337
Zenith	331

Notes

- If more than one code number is listed, try entering them one by one, until you come to the correct code for your equipment.
- In some rare cases, you may not be able to operate your non-Sony video equipment with the supplied remote commander.
- This is because your equipment may use a code that is not included with this remote commander. In this case, please use the equipment's own remote control unit.
- The code numbers for Sony equipment are assigned at the factory as follows:

VHS VCR 301 (preset code for the supplied remote commander)

302

303

8 mm VCR

Beta, ED Beta VCRs

- Whenever you remove the batteries — to replace them, for example — if too much time is taken, the code number may revert to the factory setting and must be reset.

Operating video equipment

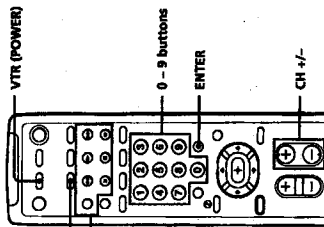

Use the video operating buttons on the remote commander to operate the video equipment. Press VTR (FUNCTION) before operating the video equipment.

Operating a VCR

Buttons on the remote commander

- To turn on or off directly Press VTR (POWER).
- To select a channel Press the 0-9 buttons.
- To change channels Press CH +/-.
- To record Press \blacktriangle while pressing \bullet . First release \blacktriangle , then release \bullet .
- To play Press \blacktriangleright .
- To stop Press \blacksquare .
- To fast forward Press $\blacktriangleright\blacktriangleright$.
- To rewind the tape Press $\blacktriangleleft\blacktriangleleft$.
- To pause Press \parallel .
- To resume normal playback, press again.
- To search the picture forward or backward Press $\blacktriangleright\blacktriangleright$ or $\blacktriangleleft\blacktriangleleft$ during playback.
- To resume normal playback, release the button.
- To change input mode Press TV/VTR.

Notes

- If the video equipment does not have a certain function, the corresponding button on this remote commander will not operate.

Turning off the system

■ KV-27V25/27V35/29V35C/29V65M/29V75M/32V25/32V35/34V35C/35V35/35V45/35V75 only

You can turn off the TV and Sony equipment with the S-Link function, such as a VCR, together when you make the S-Link connection (see page 10 for the connection).

Press SYSTEM OFF.



Operating a cable box or DBS receiver

You can program the supplied remote commander to operate a cable box or DBS receiver. Follow the procedures below to set the manufacturer's code number in the remote commander.

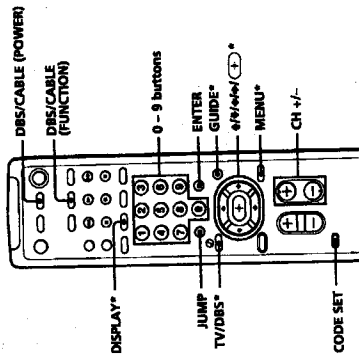

* The TV/DBS, GUIDE, DISPLAY, $\blacktriangleleft/\blacktriangleright/\bullet/\blacktriangleright$, and MENU buttons can be used only with a DBS receiver.

1 Turn off the equipment you want to set up, and press DBS/CABLE (FUNCTION).

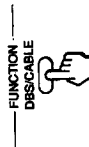

2 Press the CODE SET, DBS/CABLE (FUNCTION), and 0-9 buttons to enter the manufacturer's code number (see the chart), then press ENTER. For example, to program your remote commander to operate a Sony DBS receiver, press CODE SET, DBS/CABLE (FUNCTION), 8, 0, 1, and ENTER.

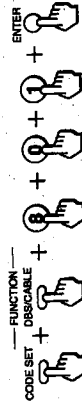

3 Press DBS/CABLE (POWER) to turn on the cable box or DBS receiver.



4 Use the cable box/DBS control buttons to check if the code number works.

For example, to operate a cable box or DBS receiver, you can use the DBS/CABLE (POWER), JUMP, CH +/-, 0-9 and ENTER buttons.

Note

- If the cable box or DBS receiver does not have a certain function, the corresponding button on this remote commander will not operate.

To operate the TV

Press TV (FUNCTION). Then use the TV control buttons to control the TV.

For more details on operating the cable box or DBS receiver

Refer to the operating instructions that come with the equipment.

If the remote commander doesn't work

- First, try repeating the setup procedures using the other codes listed for your equipment.

Manufacturer code numbers (cable box)

Manufacturer	Code number
Hannu/Regal	222, 223, 224, 225, 226
Jerrald/G. I.	201, 202, 203, 204, 205, 206, 207, 208, 218
Oak	227, 228, 229
Panasonic	219, 220, 221
Pioneer	214, 215
Scientific Atlanta	210, 211
Tocom	216, 217
Zenith	212, 213

Manufacturer code numbers (DBS receiver)

Manufacturer	Code number
Sony	801 (preset code for the supplied remote commander)

Notes

- If more than one code number is listed, try entering them one by one until you come to the correct code for your equipment.
- If you enter a new code number, the code number you previously entered at that setting is erased.
- In some rare cases, your equipment may use a code that is not provided with this remote commander and you may not be able to operate your equipment with the supplied remote commander. In this case, use the equipment's own remote control unit.
- Whenever you remove the batteries — to replace them, for example — if too much time is taken, the code numbers may revert to the factory setting and must be reset.

Troubleshooting

If the problem persists after trying the methods below, contact your nearest Sony dealer.

- ➔ **No picture (screen not lit), no sound** securely.
 - ➔ Operate with the buttons on the TV.
 - ➔ Insert the batteries in the remote commander with the correct polarity.
 - ➔ Replace the batteries with new ones if they are weak.
 - ➔ Check to see if the TV/VIDEO setting is correct when watching TV, set to TV, and when watching video tapes, set to VIDEO1, 2 or 3.
 - ➔ Try another channel. It could be station trouble.
 - ➔ Perform AUTO SET UP again using the SET UP button to return to the factory preset condition. (page 15)
- ➔ **Poor or no picture (screen lit), good sound**
 - ➔ Adjust PICTURE in the VIDEO menu. (page 22)
 - ➔ Adjust BRIGHTNESS in the VIDEO menu. (page 22)
 - ➔ Check antenna/cable connections.
 - ➔ Perform AUTO SET UP again using the SET UP button to return to the factory preset condition. (page 15)
 - ➔ Remove objects from the front of TV.
 - ➔ Check the LIGHTSENSOR setting in the VIDEO menu. (page 24)
- ➔ **Good picture, no sound**
 - ➔ Press MUTING so that "MUTING" disappears from the screen. (page 19)
 - ➔ Check the MTS setting in the AUDIO menu. (page 26)
 - ➔ Make sure SPEAKER is set to ON in the AUDIO menu. (page 27)
 - ➔ Perform AUTO SET UP again using the SET UP button to return to the factory preset condition. (page 15)
- ➔ **No color**
 - ➔ Adjust the COLOR in the VIDEO menu. (page 22)
 - ➔ Black and white programs cannot be seen in color.
 - ➔ Perform AUTO SET UP again using the SET UP button to return to the factory preset condition. (page 15)

- ➔ **Only snow and noise appear on the screen** (page 17)
 - ➔ Check the CABLE setting in the SET UP menu.
 - ➔ Check the antenna/cable connections.
 - ➔ Make sure the channel is broadcasting programs.
 - ➔ Press TV (black button) to change the input mode. (page 20)

- ➔ **Dotted lines or stripes**
 - ➔ Adjust the antenna.
 - ➔ Move the TV away from noise sources such as cars, neon signs, and hair-dryers.

- ➔ **Double images or ghosts**
 - ➔ Use a highly directional outdoor antenna or a cable (when the problem is caused by reflections from nearby mountains or tall buildings).

- ➔ **Cannot operate menu**
 - ➔ If the item you want to choose appears in gray, you cannot select it. Press TV/VIDEO correctly.

- ➔ **Cannot receive upper channels (UHF) when using an antenna**
 - ➔ Make sure CABLE is OFF in the SET UP menu. (page 17)
 - ➔ Use AUTO PROGRAM to add receivable channels that are not presently in TV memory. (pages 15, 17)

- ➔ **Cannot receive any channels when using cable TV**
 - ➔ Make sure CABLE is ON in the SET UP menu. (page 17)
 - ➔ Use AUTO PROGRAM to add receivable channels that are not presently in TV memory. (pages 15, 17)

- ➔ **Remote commander does not operate**
 - ➔ Batteries could be weak. Replace the batteries.
 - ➔ Make sure the TV's power cord is connected securely to the wall outlet.
 - ➔ Press TV (FUNCTION) when operating your TV.
 - ➔ Are fluorescent lights too close to the TV? Move them at least 3-4 feet away from the TV.

- ➔ **Cannot gain enough volume when using a cable box**
 - ➔ Increase the volume at the cable box. Then press TV (FUNCTION) and adjust the TV's volume.

- ➔ **TV malfunctions when using the S-Link function** (KV-27V25/27V35/29V35C/29V65M/29V75M/32V25/32V35/34V35C/35V75 only)
 - ➔ Make sure the TV's power cord is connected securely to the wall outlet.
 - ➔ Check the S-Link connection. (page 10)

- ➔ **The TV needs to be cleaned**
 - ➔ Clean the TV with a soft dry cloth. Never use strong solvents such as thinner or benzene, which might damage the finish of the cabinet.

Welcome!

Thank you for purchasing the Sony Trinitron® Color TV. Here are some of the features you will enjoy with your TV:

- On-screen menus that let you set the picture quality, sound, and other settings.
- Picture-in-Picture (PIP) that allows you to watch another TV channel, video or cable image as a window picture.
- Surround system that simulates the sound quality of a concert hall or movie theater (KV-27S25/27S35/29RS25/29RS25C/32S25/32S35/32TW25 only).
- SRS (SOUND RETRIEVAL SYSTEM) that allows you to receive realistic sound that recaptures audio "clues" originally present but masked in the recording process so that the action seems to happen all around you (KV-27V25/27V35/29V35C/29V65M/29V75M/32V25/32V35/34V35C/35V75/35V45/35V75 only).
- LightSensor™ that automatically adjusts the brightness of the picture (KV-27V25/27V35/29V35C/29V65M/29V75M/32V25/32V35/34V35C/35V75 only).
- S-Link™ that allows you to automatically change the TV's input mode, turn on the VCR, and play a tape by just pressing the VCR's play button (KV-27V25/27V35/29V35C/29V65M/29V75M/32V25/32V35/34V35C/35V75/35V45/35V75 only). This feature is originally designed by Sony.

Checking your model number

The instructions in this manual are for the eighteen models listed below. Before you start reading, check your model number by looking at the rear of your TV. The KV-27S25 is the model used for illustration purposes. Any differences in operation are clearly indicated in the text, for example, "KV-27S25 only."

Instructions in this manual are based on the remote commander. You can also use the controls on the TV if they have the same name as those on the remote commander.

Feature packages

Model number	One-tuner PIP	Two-tuner PIP	S-Link/LightSensor	SRS/Clock/Timer	TRK correction
KV-27S25	•				
KV-27S35		•			
KV-27V25		•	•		
KV-27V35		•	•		
KV-29RS25		•			
KV-29RS25C		•			
KV-29V35C		•	•		
KV-29V65M		•	•		
KV-29V75M		•	•		
KV-32S25		•			
KV-32S35		•			
KV-32TW25		•			
KV-32V25		•	•		
KV-32V35		•	•		
KV-34V35C		•	•		
KV-35V35		•	•		
KV-35V45		•	•		
KV-35V75		•	•		

English

Additional information for code setting of the remote commander

You can also use the following codes to set the supplied remote commander and operate the other manufacturer's equipment. To set a code, see the Operating Instructions on pages 34 and 35. For an MDP (Multi-disc player), set the code the same way as the VCR.

Manufacturer	Code number
VCR	
Magnavox	310, 308, 309
Phillips	310, 308, 309
RCA/PROSCAN	304, 305, 308, 309, 310
Sylvania	310, 308, 309, 338
MDP	
Sony	701
Kenwood	707
Magnavox	703
Marantz	702
Mitsubishi	702
Panasonic	704
Phillips	703
Pioneer	702
RCA	702
Sanyo	706
Sharp	705
Yamaha	703
Cable box	
Scientific Atlanta	209, 210, 211
DBS receivers	
RCA	802

Operating an MDP

Use the video operating buttons on the remote commander to operate the MDP. Press VTR (FUNCTION) before operating the MDP.

Operating an MDP	Buttons on the remote commander
To turn on or off	Press VTR (POWER).
To play	Press ▶
To stop	Press ■
To pause	Press II.
	To resume normal playback, press again.
To search the picture forward or backward	Keep pressing ▶▶ or ◀◀ during playback. To resume normal playback, release the button.
To search the chapter forward and backward	Press CH +/-

SECTION 2 DISASSEMBLY

2-1. REAR COVER AND SPEAKER REMOVAL

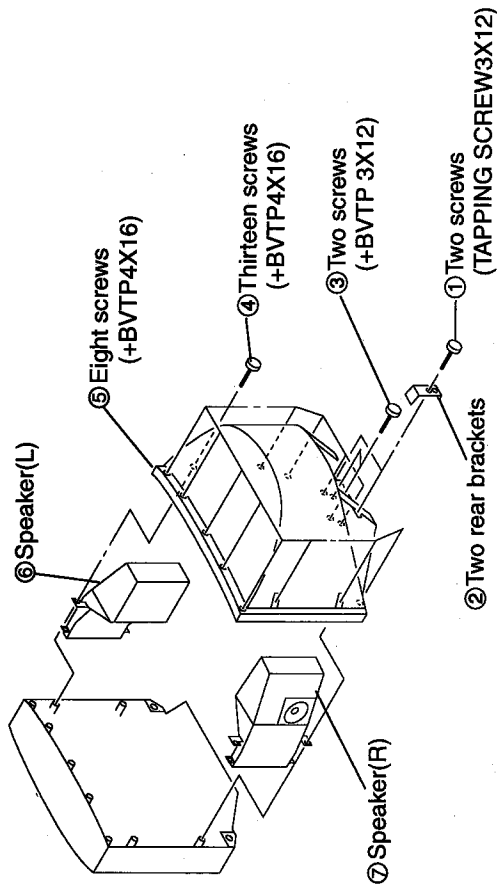

2-2. CABINET BASE REMOVAL (KV-35V75)

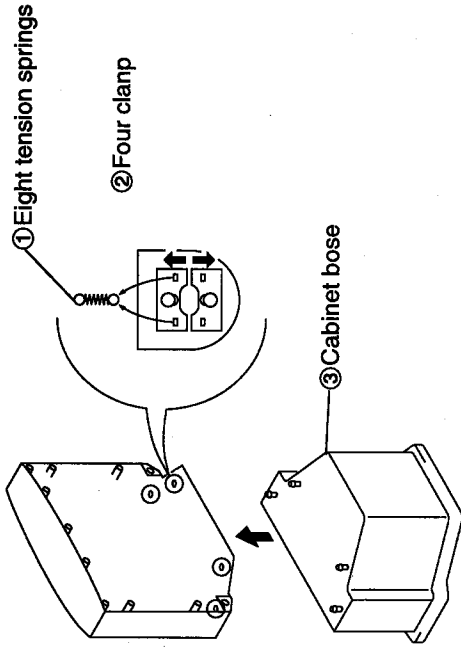

2-3. CHASSIS ASSY REMOVAL

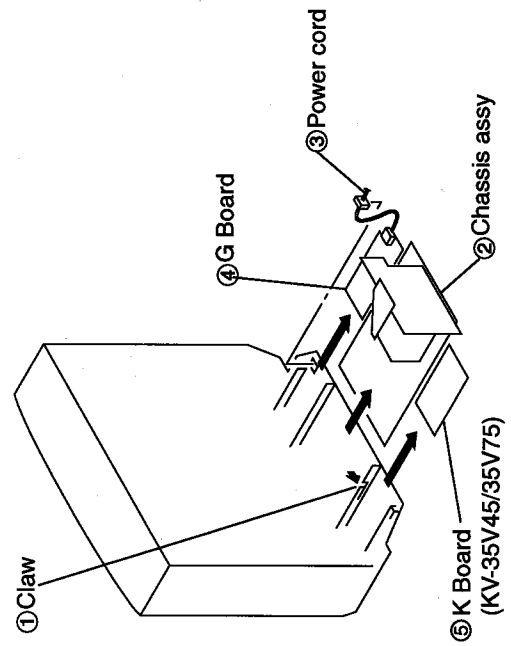

2-4. SERVICE POSITION

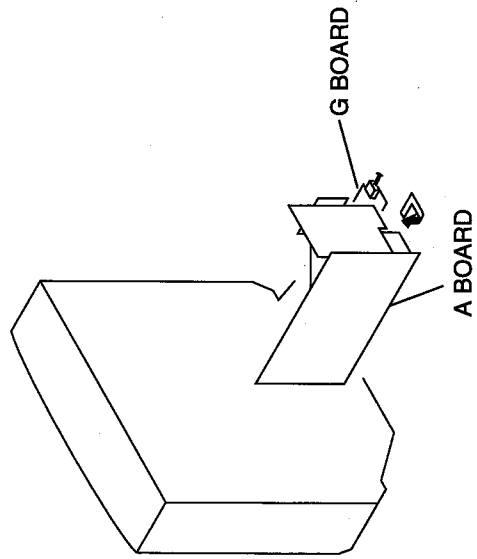

2-5. CONTROL SWITCH REMOVAL

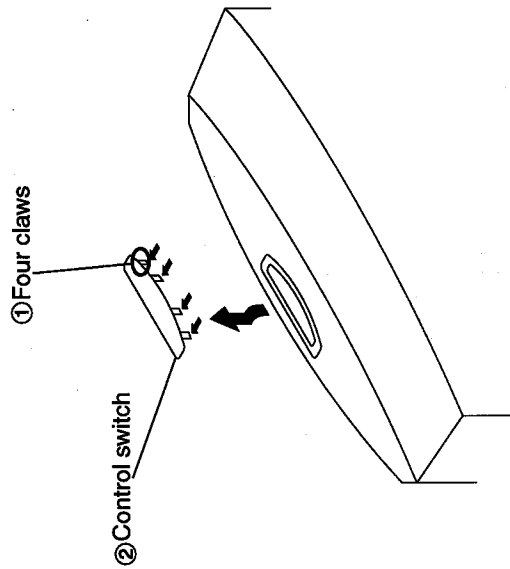

2-7. PICTURE TUBE REMOVAL

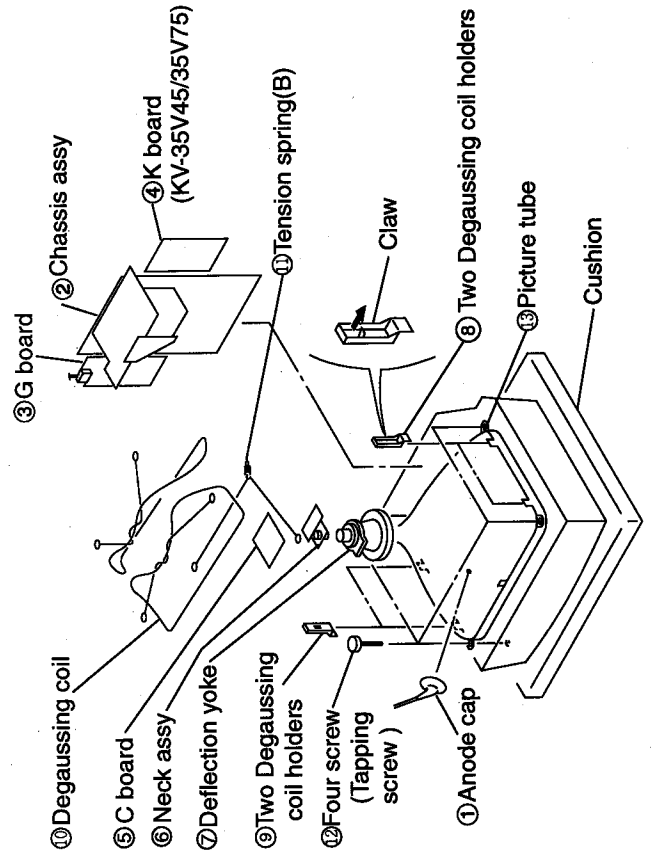

2-6. PICTURE TUBE REMOVAL

WARNING

Before removing anode cap H.V remains in the CRT even after the the power is disconnected.

To avoid electrical shock, before attempting to remove the anode cap, discharge CRT : short between anode and CRT coated earth ground strap.

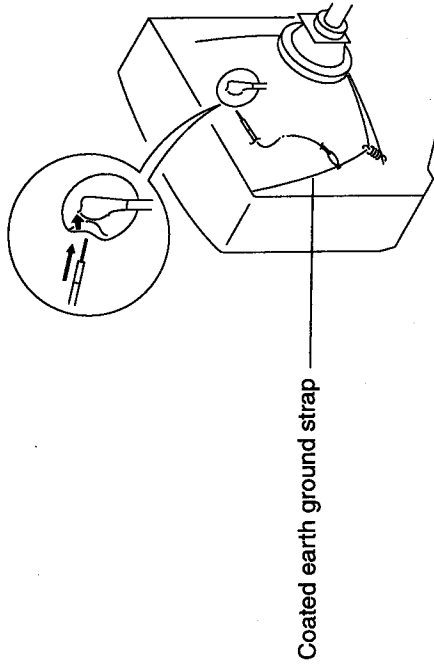

• REMOVAL OF ANODE-CAP

NOTE : Short circuit the anode of the picture tube and the anode cap to the metal chassis. CRT shield or carbon painted on the CRT, after removing the anode.

• REMOVING PROCEDURES

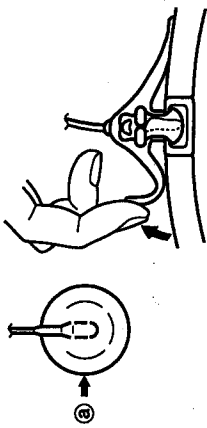

① Turn up one side of the rubber cap in the direction indicated by the arrow **a**.

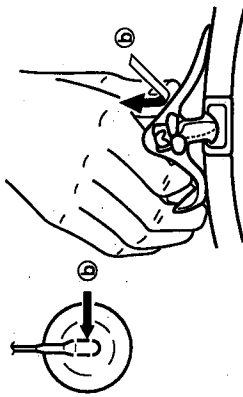

② Using a thumb pull up the rubber cap firmly in the direction indicated by the arrow **b**.

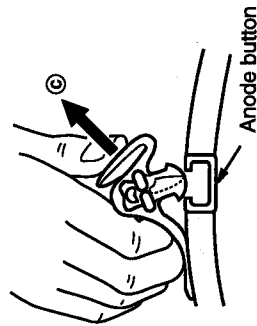

③ When one side of the rubber cap is separated from the anode button, the anode-cap can be removed by turning up the rubber cap and pulling up it in the direction of the arrow **c**.

• HOW TO HANDLE AN ANODE-CAP

- ① Don't hurt the surface of anode-caps with sharp shaped material!
- ② Don't press the rubber hardly not to hurt inside of anode-caps! A material fitting called as shatter-hook terminal is built in the rubber.
- ③ Don't turn the foot of rubber over hardly! The shatter-hook terminal will stick out or hurt the rubber.

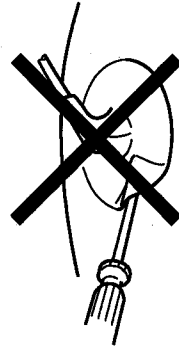
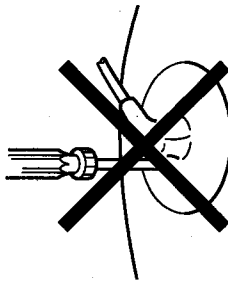

CAUTION

Be sure to attach AC Cord to Rear Cover with the hook in the following way for after service.
Then check if the AC cord is protected against being pressed under the set.

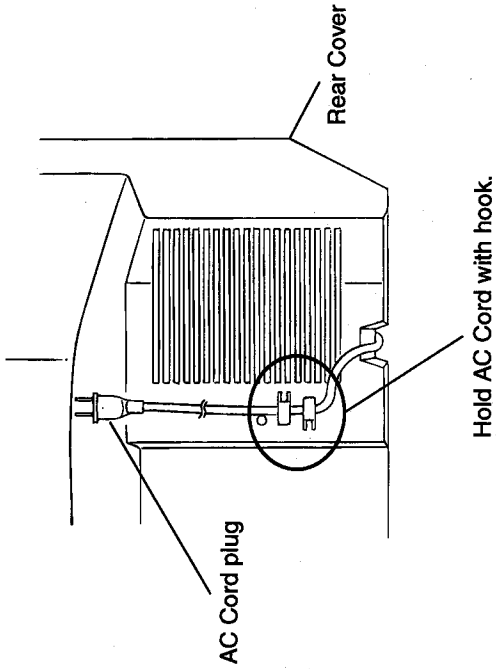

ADJUSTMENT ITEM AND PROCEDURE	EQUIPMENT AND SIGNAL	MEASUREMENT POSITION	ADJUSTMENT LOCATION	ILLUSTRATION AND SHAPE AND NUMBER
<p>B+ VOLTAGE CONFIRMATION</p> <p>The following adjustments should always be performed when replacing the following *components.</p> <ol style="list-style-type: none"> 1) Supply *Voltage AC to with *variable auto-transformer. 2) Input an entirely *signal. 3) Set the PICTURE control and the BRIGHTNESS control to adjustment. 4) Confirm the voltage of *TP is less than *Voltage DC. 5) If step 4) is not satisfied, replace the *components repeat above steps. 	<p>* Variable auto-transformer * Monoscope</p>	<p>*IC643, R661</p> <p>*G Board CN641 Pin 1 - ground</p>	<p>*PICTURE, BRIGHTNESS initial reset</p> <p>*R661</p>	<p>*130 ± 2.0 V AC</p> <p>* Less than 136.5 VDC</p>

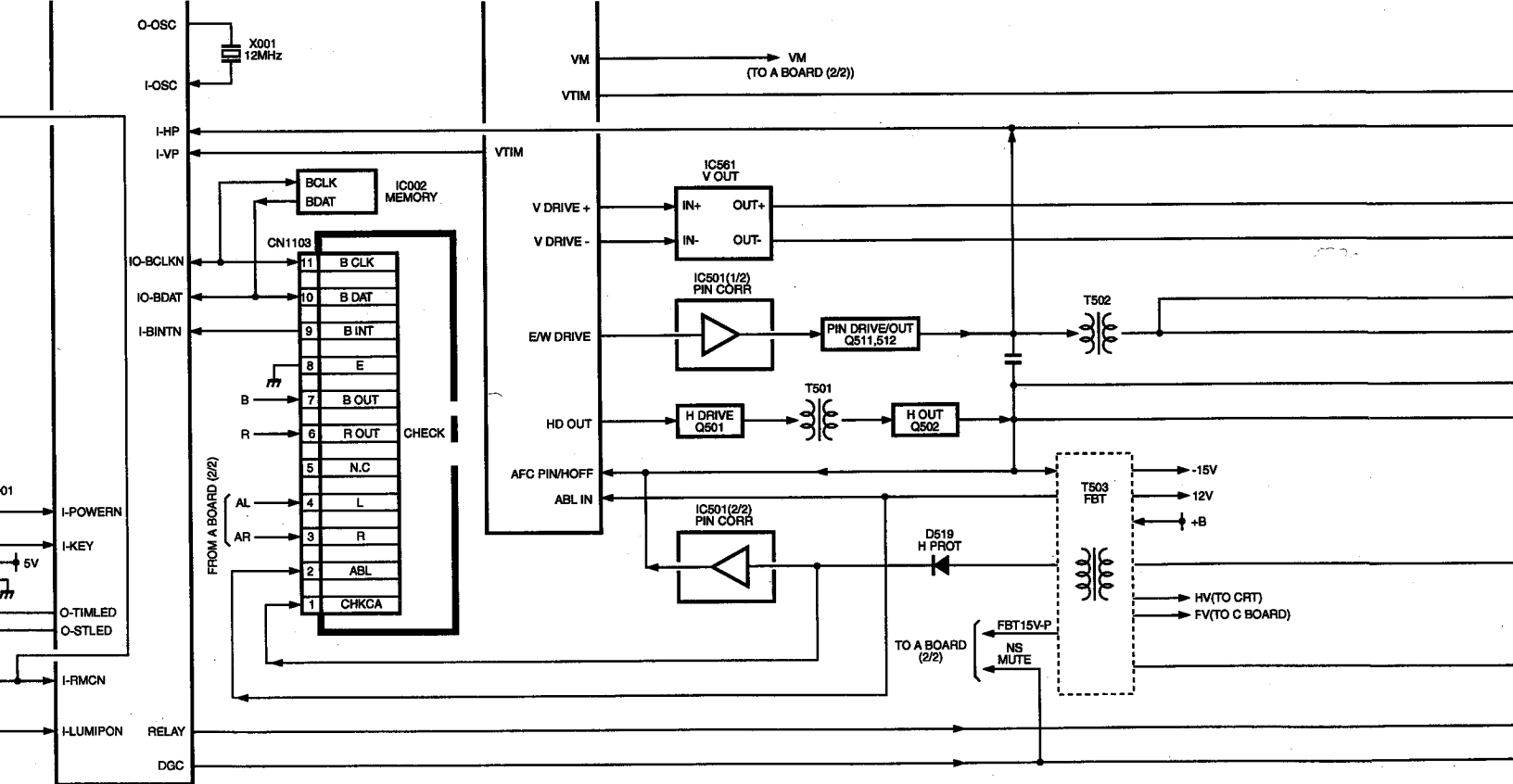
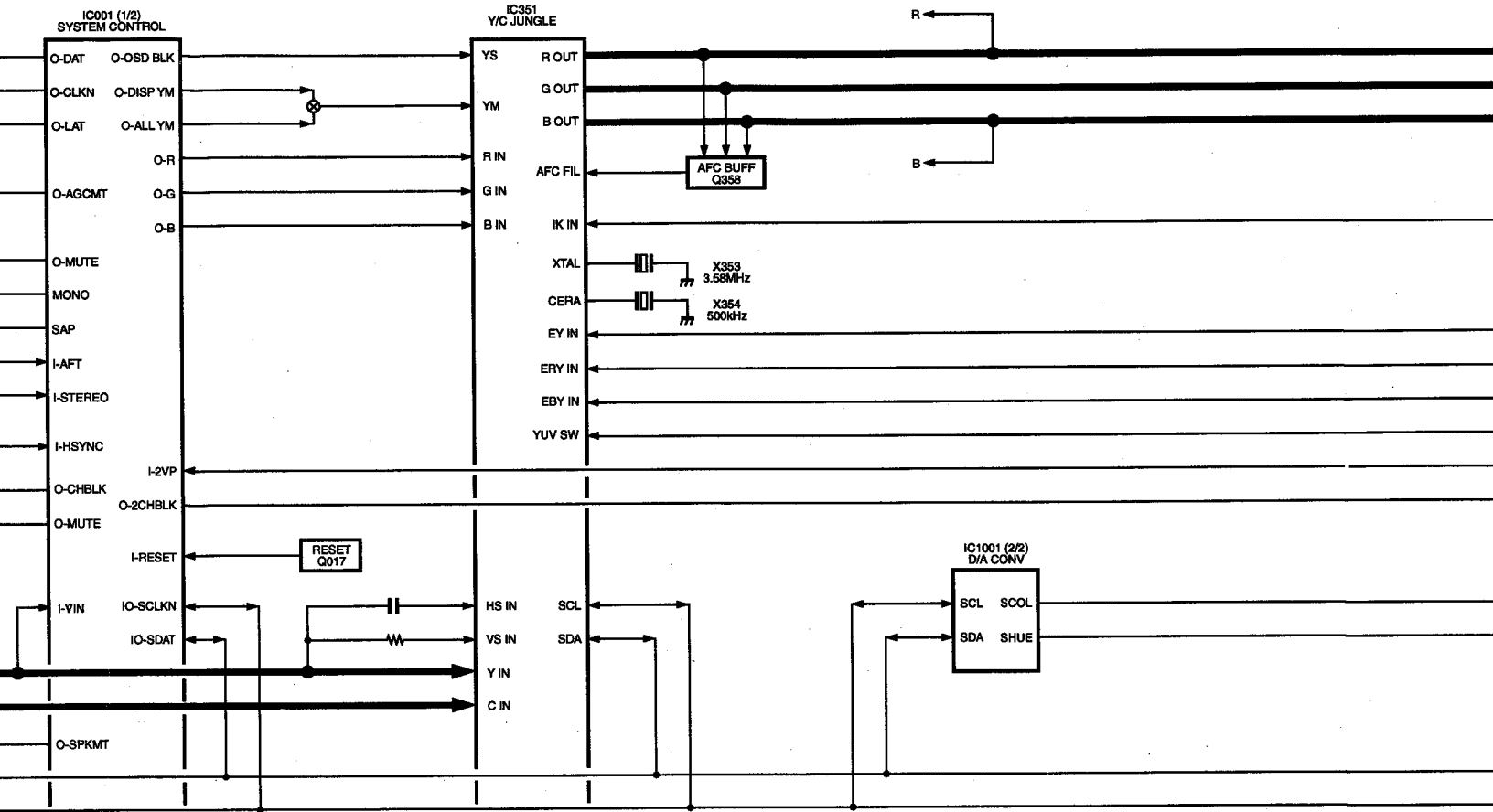

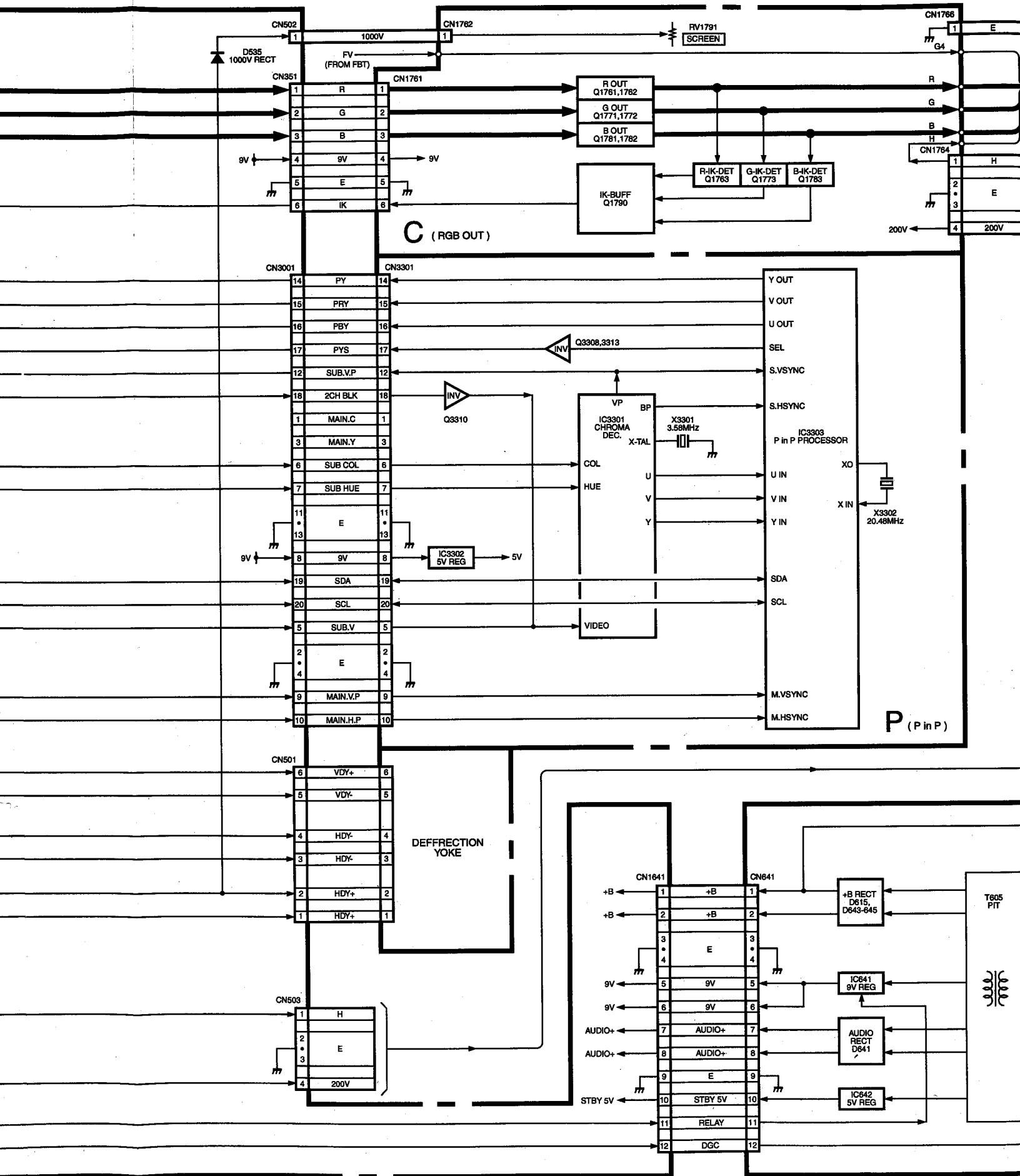

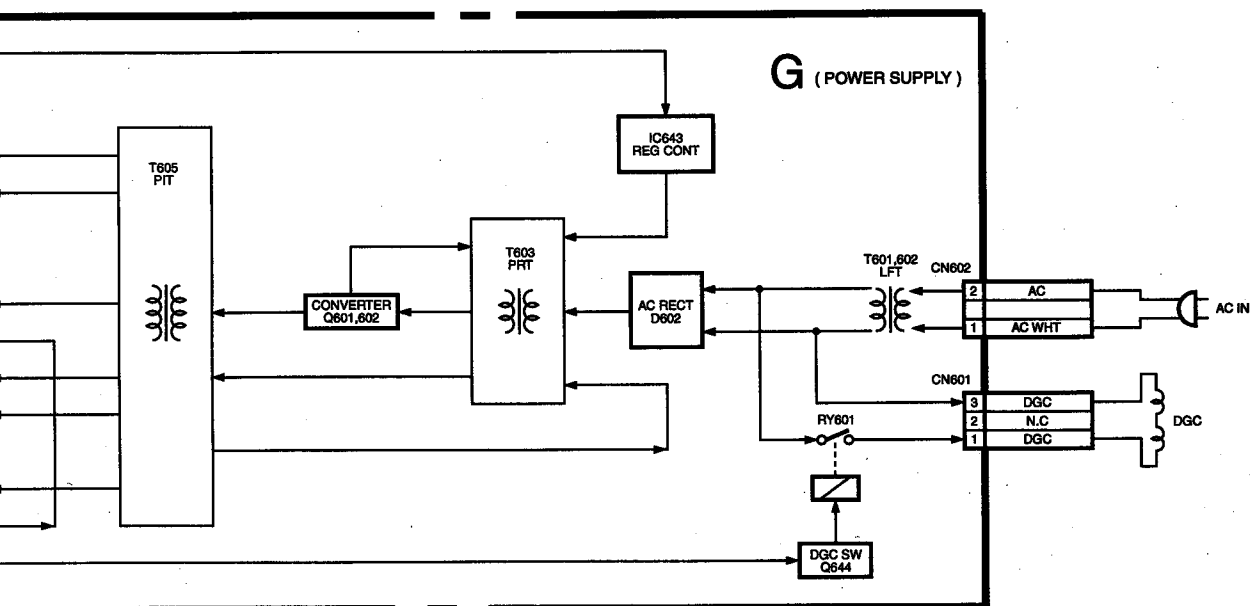
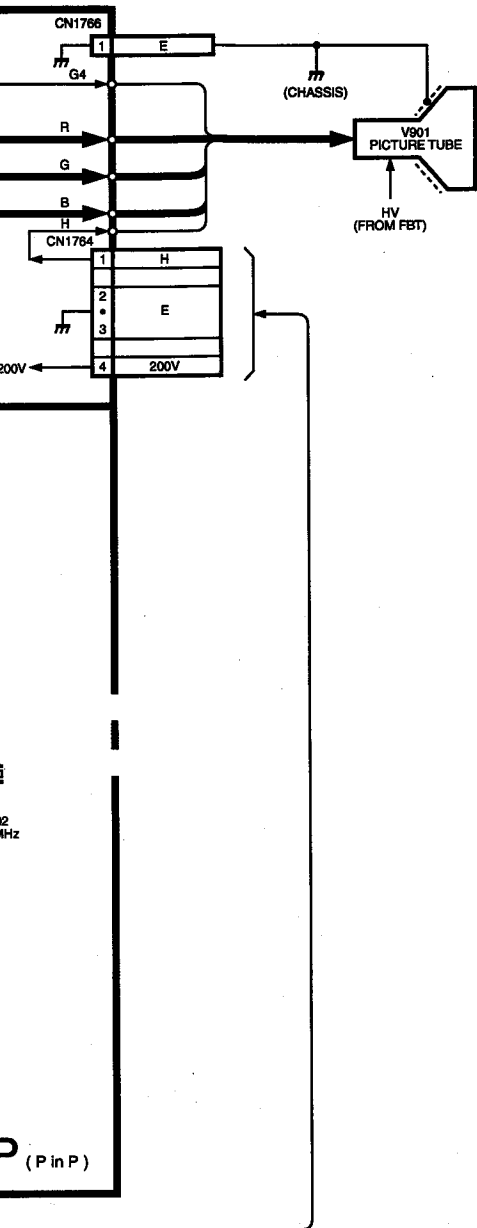

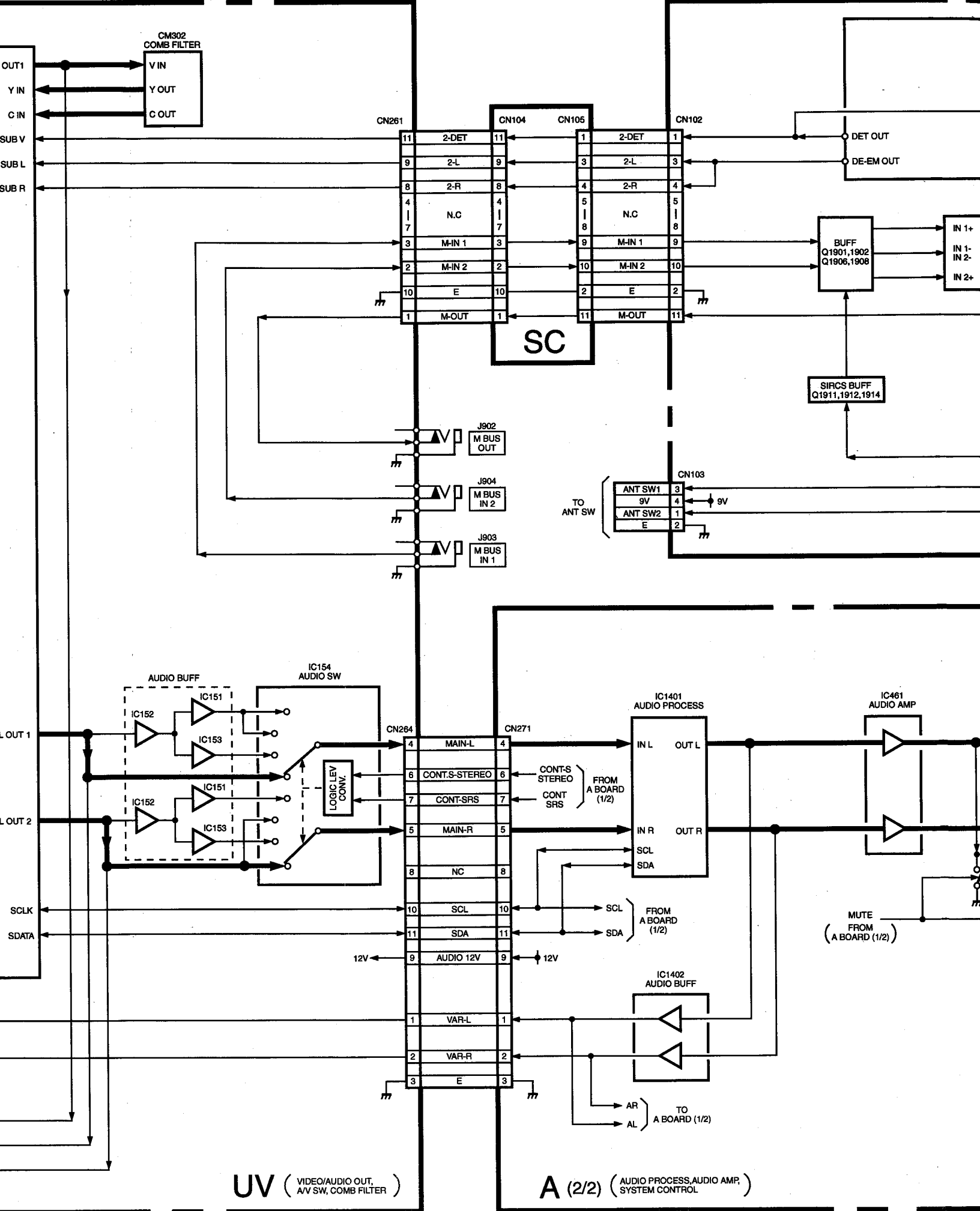

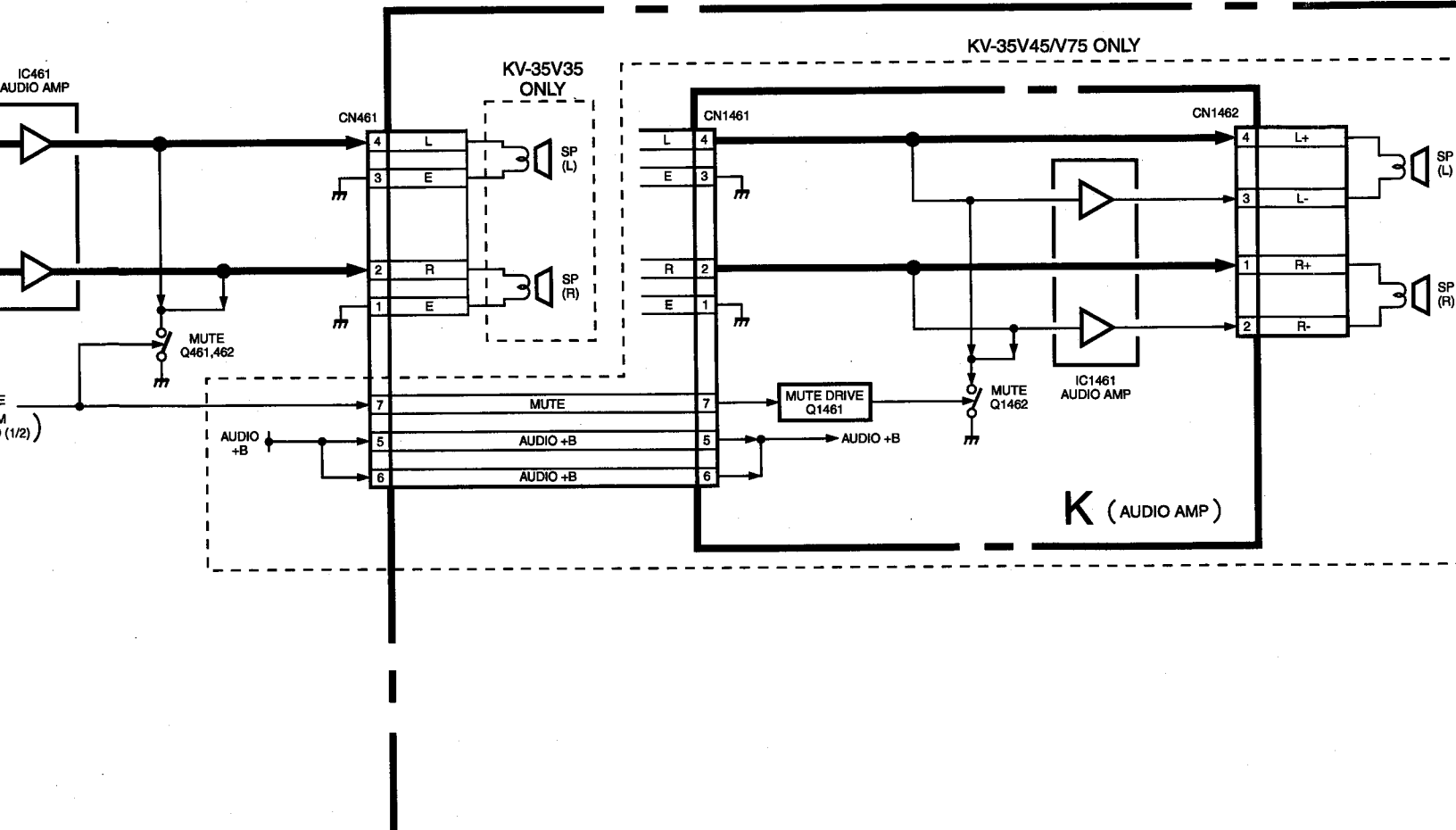
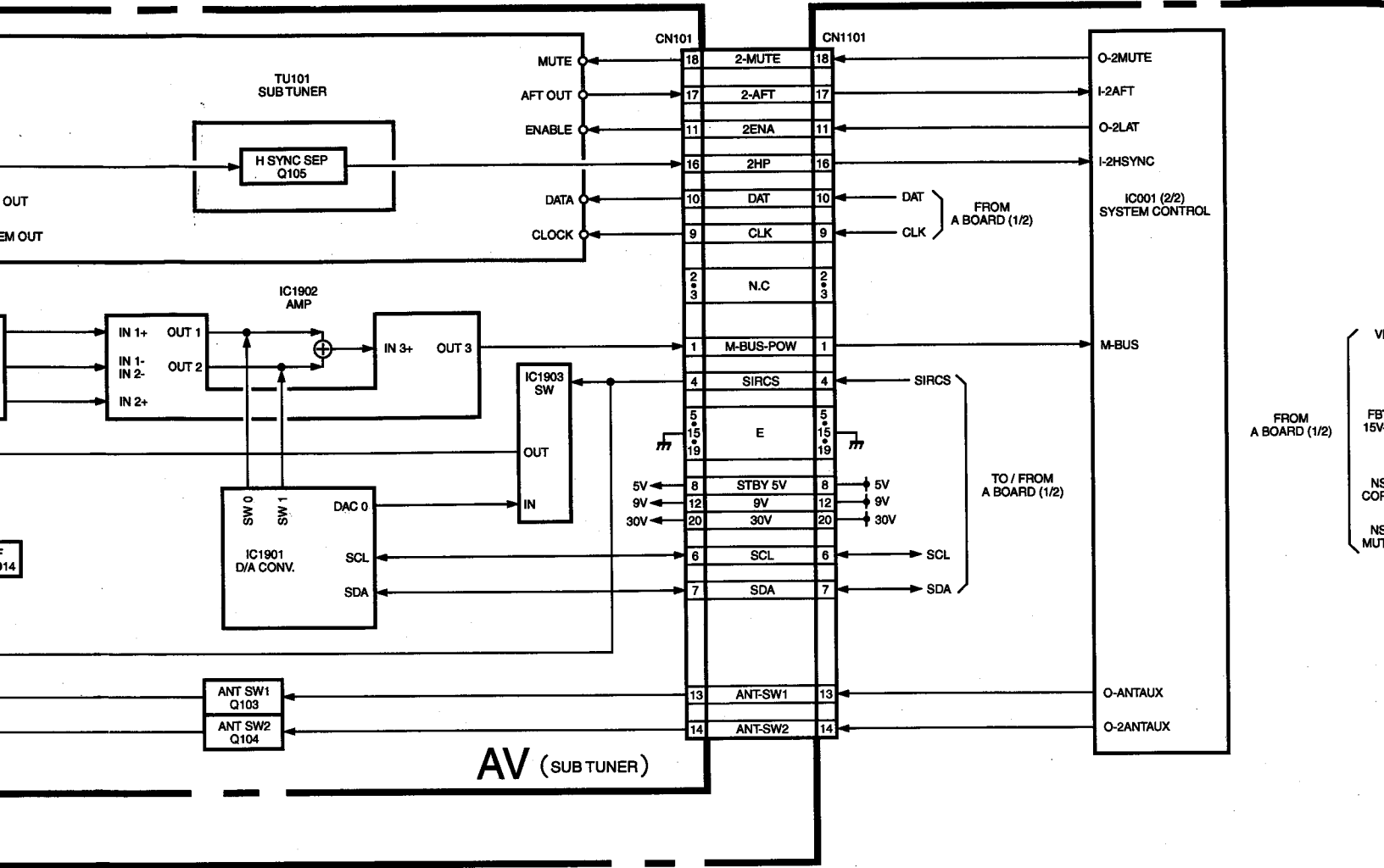

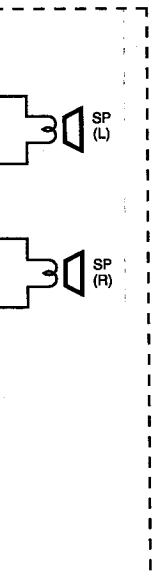
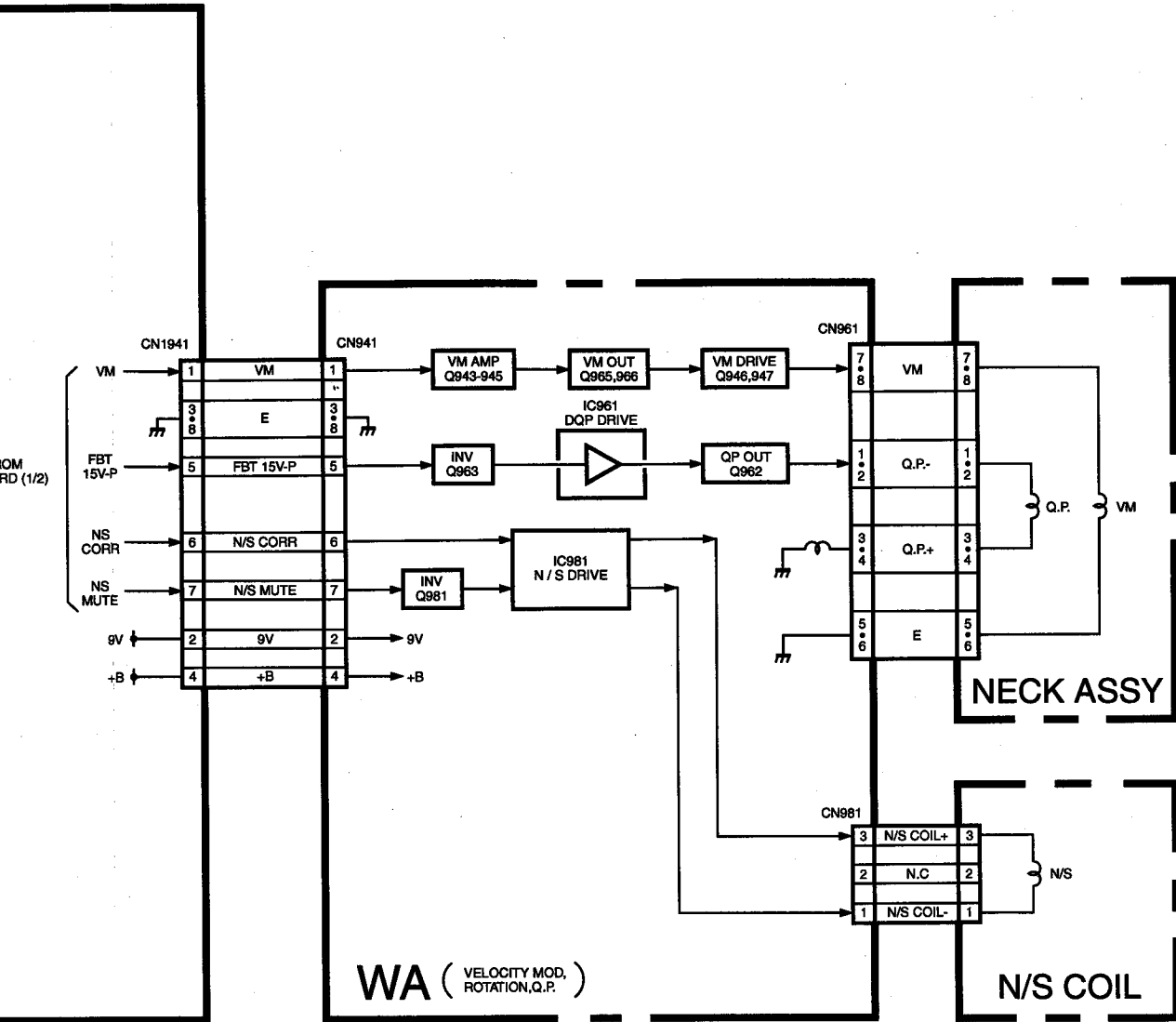

SECTION 4 DIAGRAMS

4-2. CIRCUIT BOARDS LOCATION

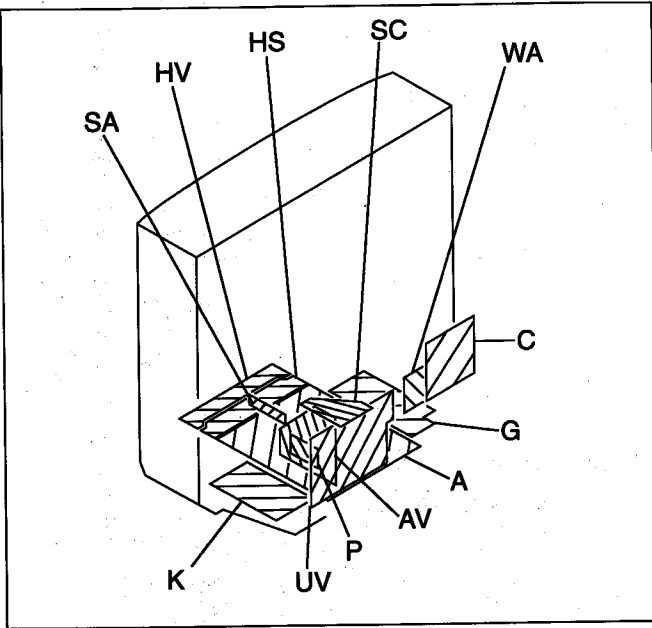

4-3. PRINTED WIRING BOARDS AND SCHEMATIC DIAGRAMS

Note:

- All capacitors are in μF unless otherwise noted. $\text{pF} : \mu\text{F} \ 50\text{V}$ or less are not indicated except for electrolytics and tantalums.
- All electrolytics are in 50V unless otherwise specified.
- All resistors are in ohms.
 $\text{k}\Omega=1000\Omega$, $\text{M}\Omega=1000\text{k}\Omega$
- Indication of resistance, which dose not have one for rating electrical power, is as follows.

Pitch : 5mm
Rating electrical power : $\frac{1}{4}\text{W}$

- $\frac{1}{4}\text{W}$ in resistance, $\frac{1}{10}\text{W}$ and $\frac{1}{8}\text{W}$ in chip resistance.
- : nonflammable resistor.
- : fusible resistor.
- Δ : Internal component.
- : panel designation and adjustment for repair.
- All variable and adjustable resistors have characteristic curve B, unless otherwise noted.
- The components identified by in this basic schematic diagram have been carefully factory-selected for each set in order to satisfy regulations regarding X-ray radiation.
Should replacement be required, replace only with the value originally used.
- When replacing components identified by , make the necessary adjustments indicated. If results do not meet the specified value, change the component identified by and repeat the adjustment until the specified value is achieved.
(Refer to R530 and R531 adjustment on Page 26 - 27.)
- When replacing the part in below table, be sure to perform the related adjustment.

Part replaced()	Adjustment()
IC351, IC501, D519, D520, D521 C531, C532, R387, R529, R530, R531, R532, R550, T503.....A BOARD IC643, R661.....G BOARD	R530, R531

- As to the voltage shown by the semiconductors on the Schematic Diagram, see the another list.
- Readings are taken with a color-bar signal input.
- Readings are taken with a 10M Ω digital multimeter.
- Voltages are dc with respect to ground unless otherwise noted.
- Voltage variations may be noted due to normal production tolerances.
- All voltages are in V.
- S : Measurement impossibility.
- : B+line.
- : B-line.
(Actual measured value may be different).
- : signal path. (RF)
- Circled numbers are waveform references.

Reference information

- RESISTOR : RN METAL FILM
: RC SOLID
: FPRD NONFLAMMABLE CARBON
: FUSE NONFLAMMABLE FUSIBLE
: RW NONFLAMMABLE WIREWOUND
: RS NONFLAMMABLE METAL OXIDE
: RB NONFLAMMABLE CEMENT
: ※ ADJUSTMENT RESISTOR
- COIL : LF-8L MICRO INDUCTOR
- CAPACITOR : TA TANTALUM
: PS STYROL
: PP POLYPROPYLENE
: PT MYLAR
: MPS METALIZED POLYESTER
: MPP METALIZED POLYPROPYLENE
: ALB BIPOLAR
: ALT HIGH TEMPERATURE
: ALR HIGH RIPPLE

Note: The symbol display is on the component side.

The components identified by shading and mark are critical for safety. Replace only with part number specified.

The symbol indicate fast operating fuse. Replace only with fuse of same rating as marked.

Note: Les composants identifiés par un tramé et une marque sont critiques pour la sécurité. Ne les remplacer que par une pièce portant le numéro spécifié.

Le symbole indique une fusible a action rapide. Doit être remplacée par une fusible de même valeur, comme marqué.

NOTE:

P BOARD IC VOLTAGE LIST

IC	pin	volt	pin	volt
IC3301	1	GND	4	2.3
	2	NC	5	5.1
	3	GND	6	GND
	4	4.0	7	0.5
	5	6.8	8	0
	6	GND	9	0.6
	7	0.2	10	5.2
	8	0	11	2.1
	9	1.8	12	0.3
	10	0.3	13	NC
	11	8.2	14	-3.0
	12	8.2	15	GND
	13	3.9	16	GND
	14	3.4	17	0.7
	15	0	18	0.5
	16	2.8	19	0.2
	17	NC	20	0.3
	18	2.5	21	5.1
	19	3.5	22	5.2
	20	3.0	23	NC
	21	3.0	24	NC
	22	4.7	25	GND
	23	GND	26	NC
	24	2.9	27	GND
IC3302	IN	9.1	28	2.3
	OUT	5.3	29	5.2
IC3303	1	GND	30	2.6
	2	3.2	31	4.2
	3	2.6	32	2.5

All voltages are in V

P BOARD TRANSISTOR VOLTAGE LIST

	B	C	E
Q3301	5.3	9.1	4.7
Q3305	0.5	GND	1.2
Q3306	0.8	GND	1.4
Q3307	0.6	GND	1.3
Q3308	0	GND	2.8
Q3310	0	5.2	GND
Q3312	0	0	0.8
Q3313	0.8	0.4	GND

All voltages are in V

• P BOARD WAVEFORMS

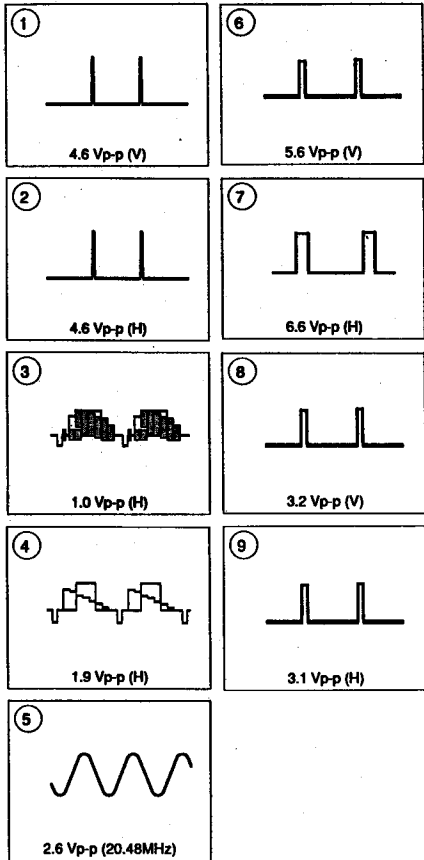

P [P I N P]

- P BOARD - < Component Side >

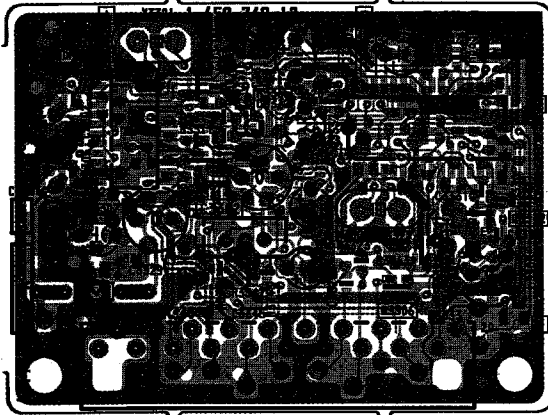

< Conductor Side >

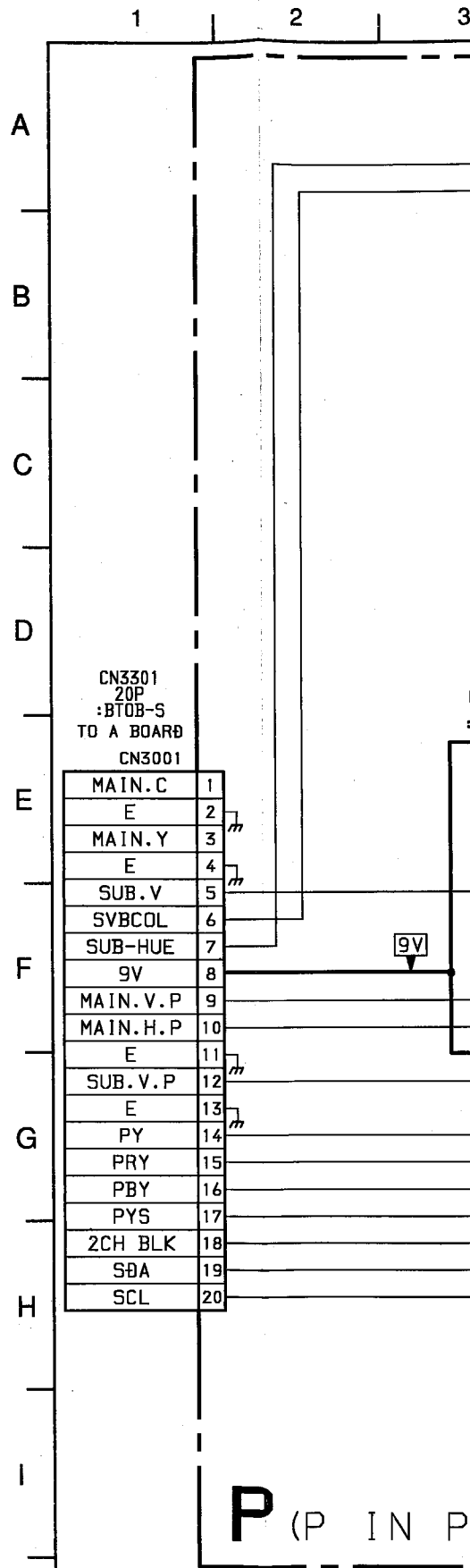
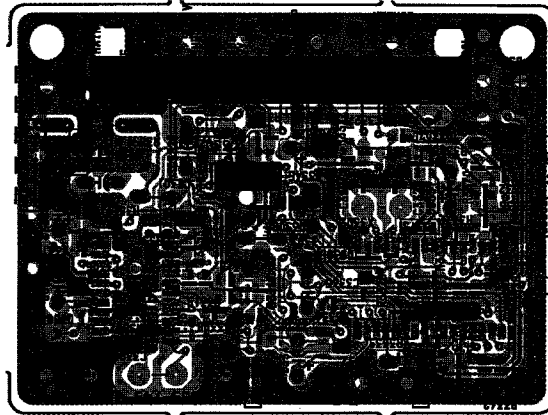

NOTE:

- [Pattern] : Pattern from the side which enables seeing.
- [Pattern] : Pattern of the rear side.

CN3301
20P
:BTOB-S
TO A BOARD
CN3001

MAIN.C	1
E	2
MAIN.Y	3
E	4
SUB.V	5
SVBCOL	6
SUB-HUE	7
9V	8
MAIN.V.P	9
MAIN.H.P	10
E	11
SUB.V.P	12
E	13
PY	14
PRY	15
PBY	16
PYS	17
2CH BLK	18
S0A	19
SCL	20

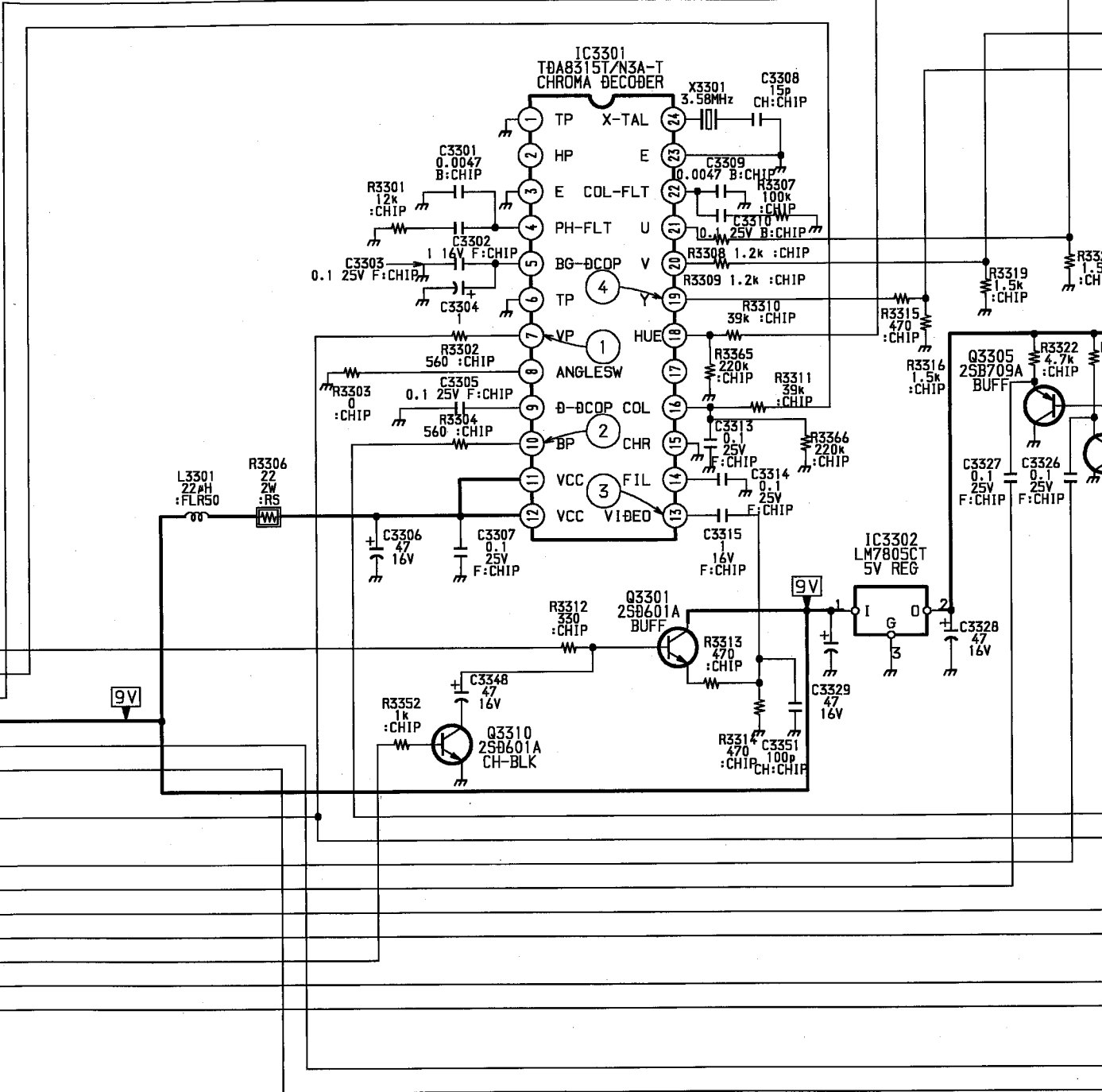

P (P IN P)

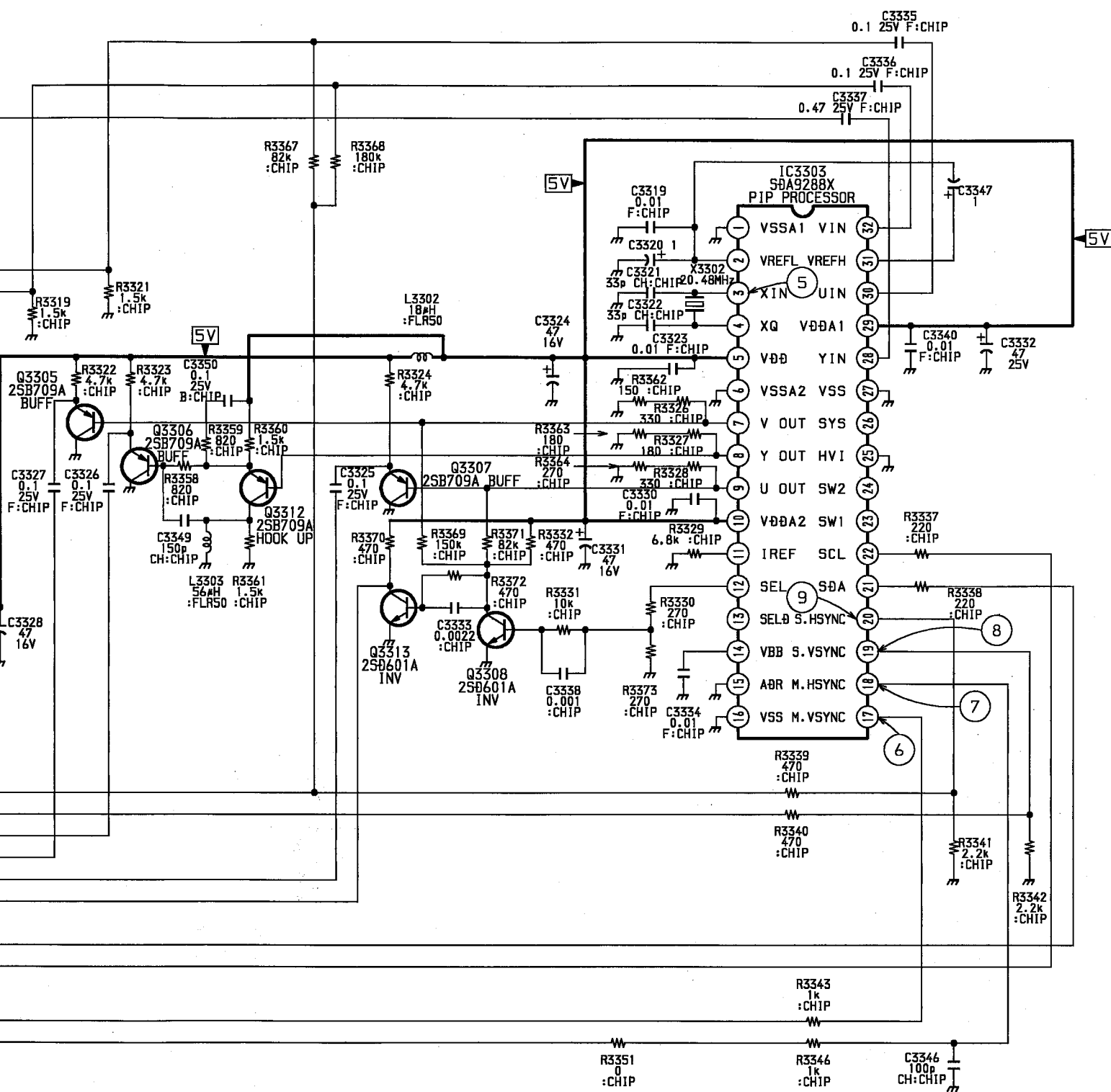

A BOARD: IC1001 CXA1315M

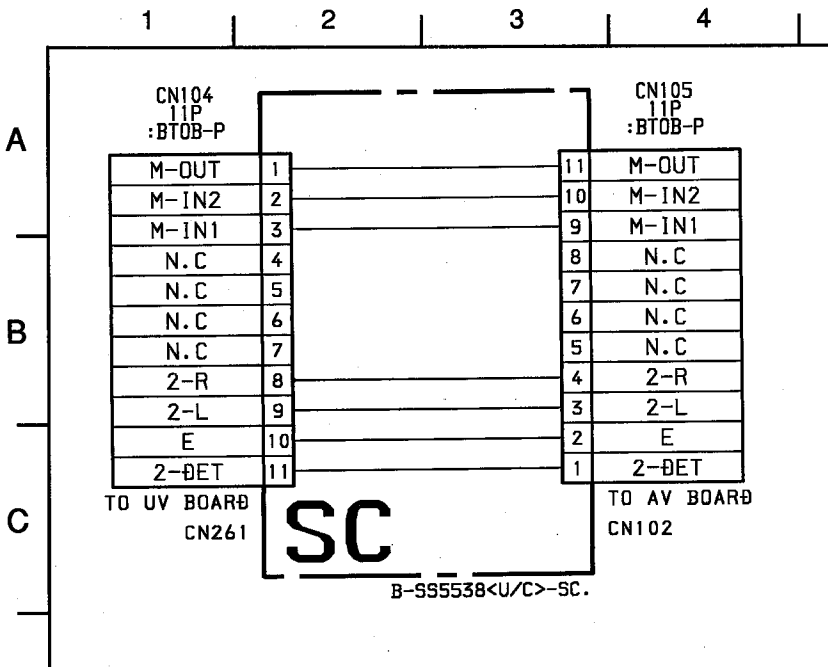
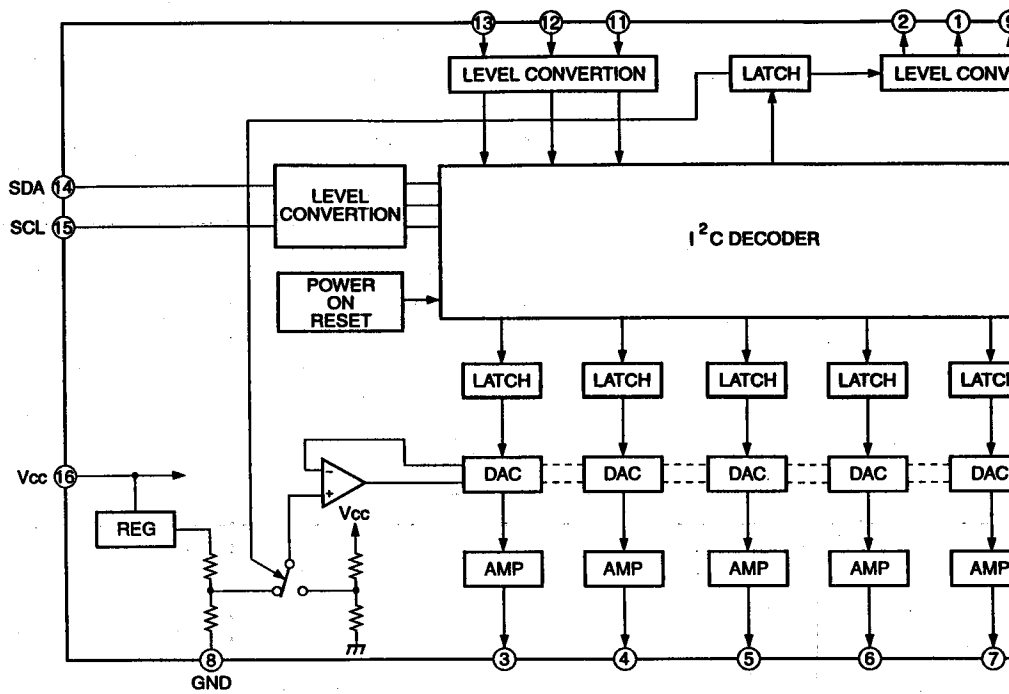

SC

- SC BOARD -

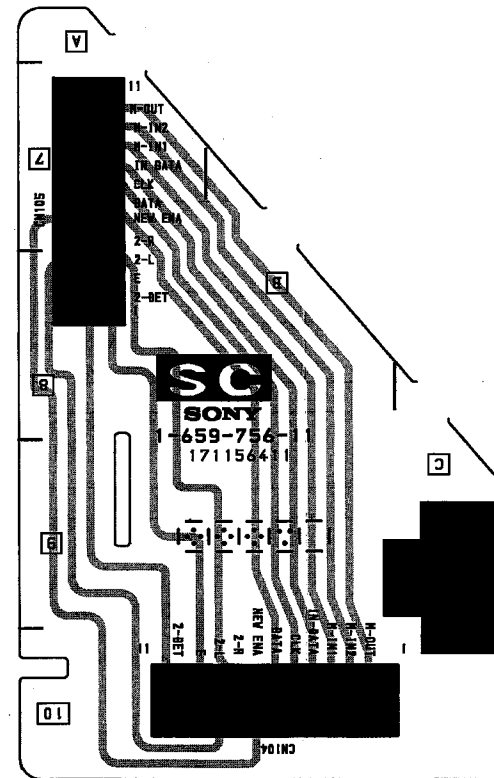

Schematic diagrams

← **P** board **SC** board →

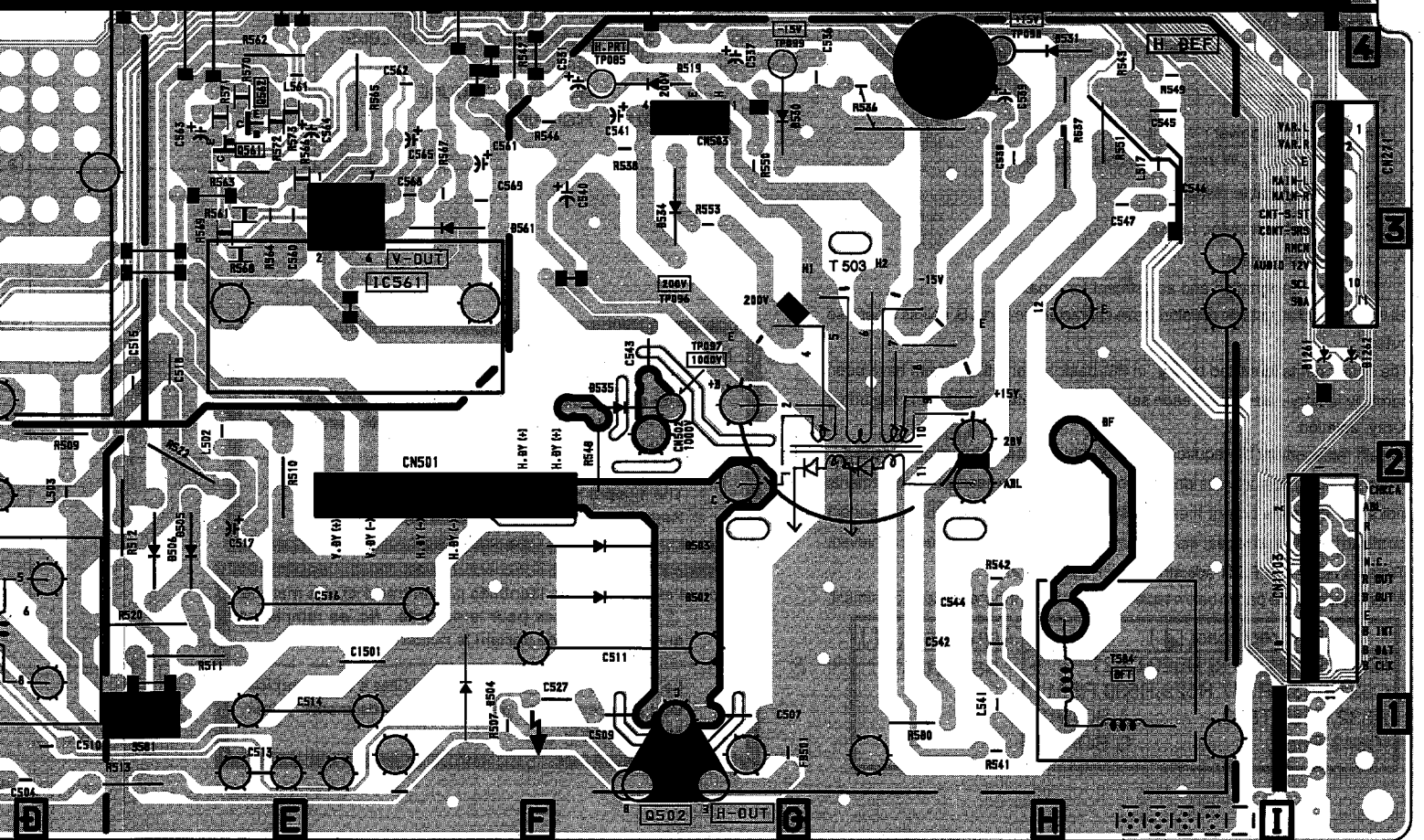
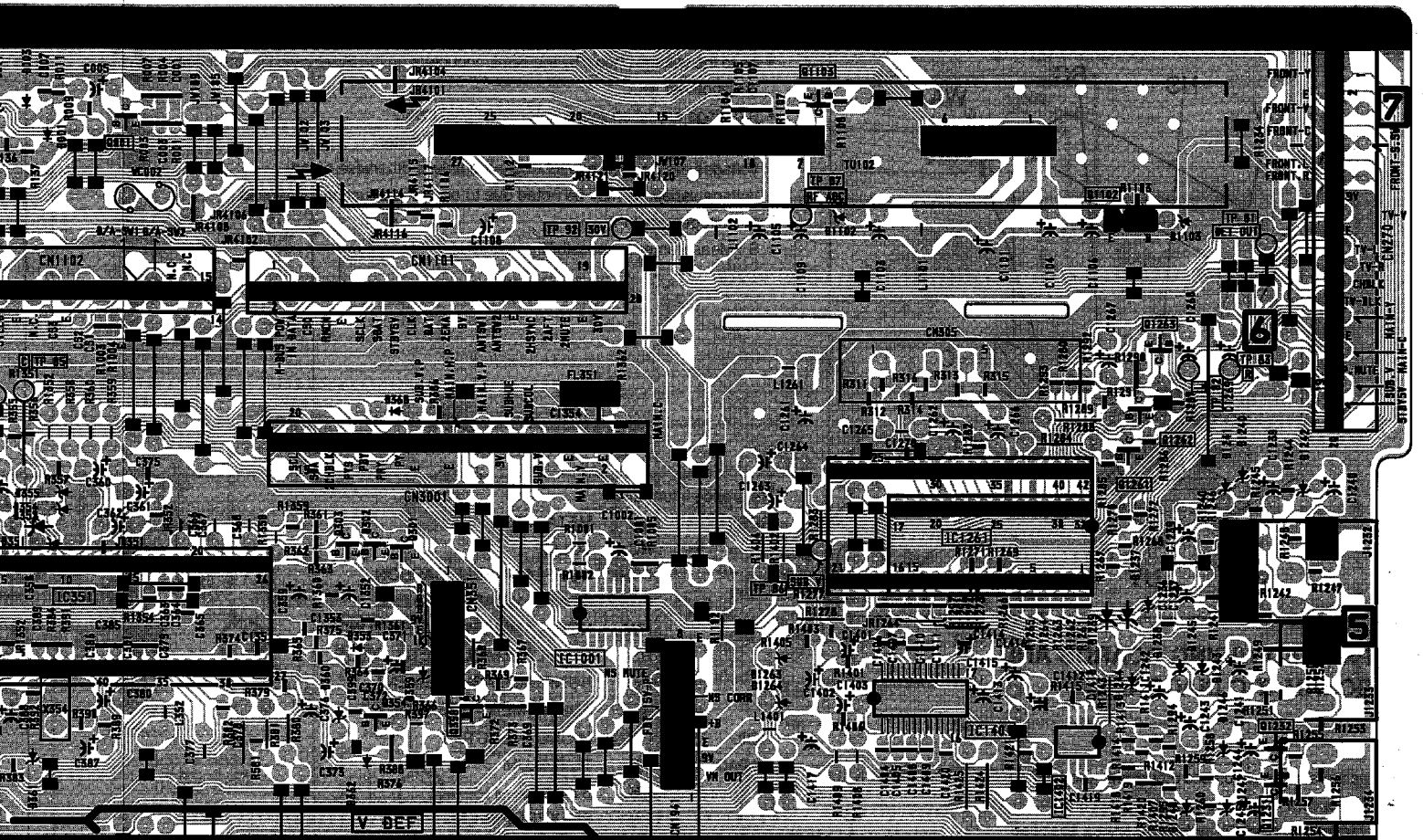

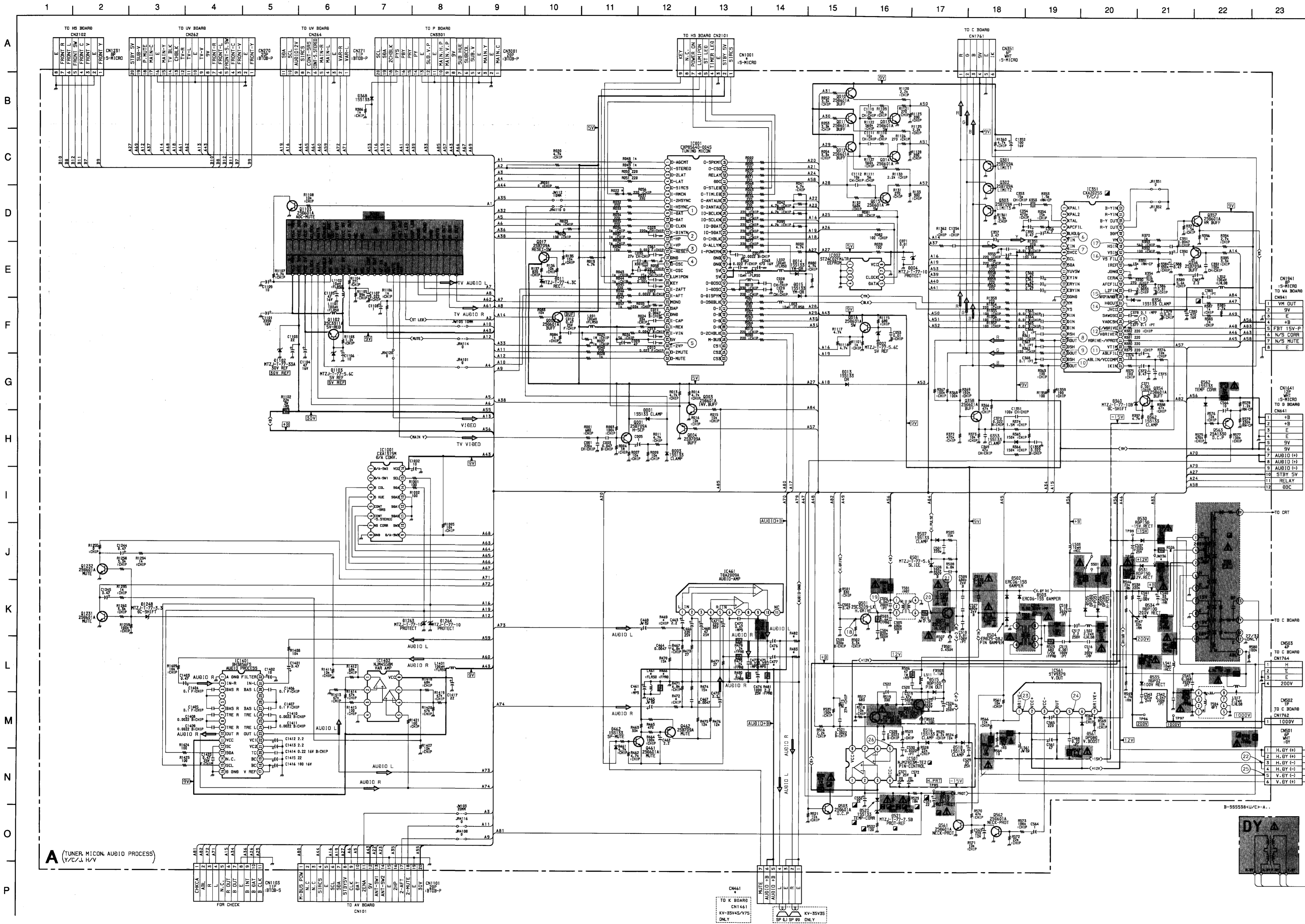

A BOARD IC VOLTAGE LIST

IC001	pin	volt	pin	volt	pin	volt	pin	volt	
	1	0	52	0	31	3.1	6	0.6	
	2	0	53	4.9	32	3.2	7	3.8	
	3	0	54	4.9	33	3.7	8	GND	
	4	0	55	4.9	34	4.5	9	0	
	5	0	56	5.0	35	4.8	10	0	
	6	5.0	57	5.0	36	8.7	11	GND	
	7	0	58	0	37	3.4	12	GND	
	8	0	59	3.7	38	3.6	13	GND	
	9	0.8	60	0.5	39	4.1	14	5.0	
	10	0	61	4	40	4.3	15	5.0	
	11	0	62	4.8	41	2.5	16	8.7	
	12	5.0	63	0	42	GND	IC1401	1	GND
	13	4.2	64	4.6	43	2.8	2	4.3	
	14	1.3	65	0	44	2.8	3	4.3	
	15	5.0	2	GND	45	4.1	4	4.3	
	16	GND	3	GND	46	3.3	5	0	
	17	2.6	4	GND	47	6.0	6	4.3	
	18	0	5	5.0	48	0.4	7	4.3	
	19	3.1	6	5.0	49	0	8	4.4	
	20	5.0	7	GND	50	0	9	4.4	
	21	2.0	8	5.0	IC461	1	1.5	10	4.4
	22	2.0	1	NC	2	3.5	11	8.7	
	23	0	2	NC	3	12.2	12	3.8	
	24	0	3	2.2	4	3.6	13	4.9	
	25	GND	4	5.9	5	1.5	14	0	
	26	0	5	4.1	6	4.1	15	5.0	
	27	1.6	6	4.6	7	0	16	0	
	28	2.4	7	4.3	8	0.3	17	4.0	
	29	5.0	8	2.2	9	2.8	18	4.0	
	30	0.2	9	2.2	10	0.3	19	2.0	
	31	0	10	5.2	11	0	20	2.0	
	32	0	11	0.3	12	3.4	21	0	
	33	0	12	6.6	13	2.9	22	0	
	34	0	13	6.3	14	6.3	23	4.3	
	35	0	14	6.3	4	-16.5	24	4.3	
	36	0	15	GND	5	2.3	25	4.3	
	37	0	16	0	6	2.8	26	4.3	
	38	0	17	0	7	-16.3	27	4.3	
	39	0	18	5.2	8	12.6	28	4.3	
	40	0	19	5.2	9	12.6	29	0	
	41	0	20	1.6	10	12.6	30	4.3	
	42	0	21	4.0	3	-14.5	31	4.3	
	43	0	22	2.2	4	-16.6	32	5.6	
	44	3.0	23	5.1	5	4.2	33	4.3	
	45	3.0	24	1.8	6	13.4	34	4.3	
	46	5.0	25	4.5	7	1.6	3	4.3	
	47	5.0	26	2.3	1	0	4	GND	
	48	GND	27	4.7	2	0	5	4.3	
	49	GND	28	1.7	3	3.2	6	4.3	
	50	5.0	29	6.8	4	2.8	7	4.3	
	51	0	30	0.7	5	0.5	8	8.7	

A BOARD TRANSISTOR VOLTAGE LIST

Q001	B	C	E
Q001	5.2	0.9	5.0
Q002	4.8	5.0	4.1
Q003	-0.4	4.3	GND
Q004	0.8	GND	1.3
Q010	0	8.7	0
Q011	0	8.7	0
Q012	0	8.7	0
Q013	-0.2	0	GND
Q014	-0.2	0	GND
Q015	-0.2	0	GND
Q016	5.8	8.7	5.1
Q017	4.4	5.0	5.0
Q301	4.0	GND	2.2
Q302	4.0	GND	1.8
Q303	4.0	GND	2.0
Q354	0.2	GND	-0.5
Q356	4.9	GND	-5.6
Q357	3.6	8.7	0
Q358	1.9	8.7	0
Q461	0.8	0	0
Q462	20.0	20.6	20.7
Q501	-0.7	105.8	GND
Q502	0	136.1	0
Q503	0	8.3	GND
Q511	-16.3	-13.0	-16.5
Q512	-16.9	19.1	16.0
Q583	134.3	0.4	134.9
Q1102	6.0	9.2	5.3
Q1103	0	2.5	GND
Q1231	0	0	GND
Q1232	0	0	GND

All voltages are in V
*Can not measured

A BOARD

Component	Value	Component	Value
C481	22 25V	KV-35V45/V75	
C476	1000 25V	JW(5)	
C477	1000 25V	JW(5)	
CN461	4P		
L461	10 μH	15 μH	
R466	2.2K	5.6K	
R469	2.2K	3.3K	
R482	2.2K		
R483	2.2K		
R523	8.2K	10K	

A BOARD: IC561 STV9379

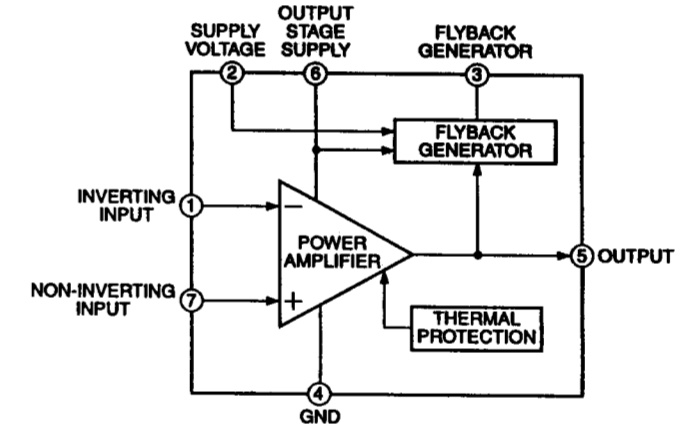

A BOARD WAVEFORMS

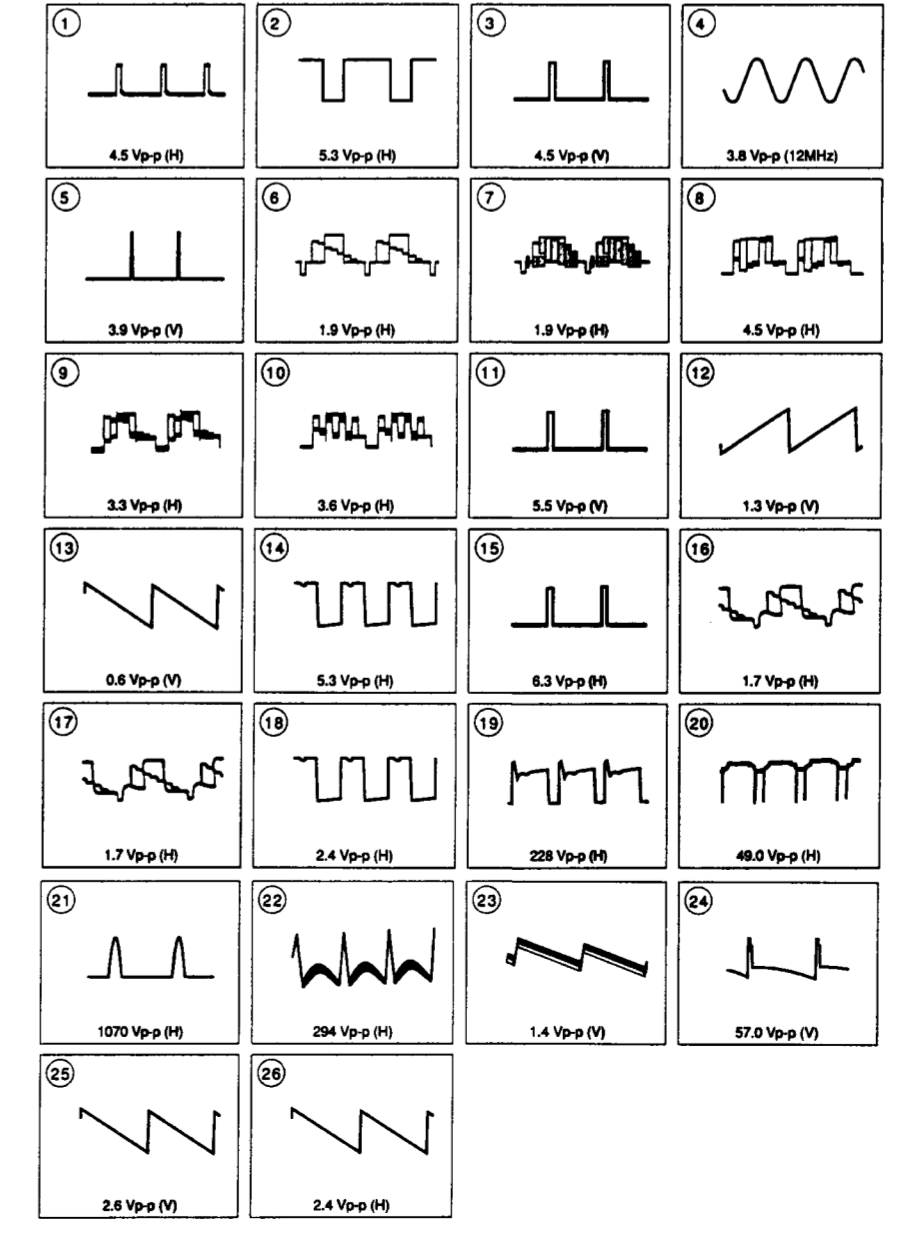

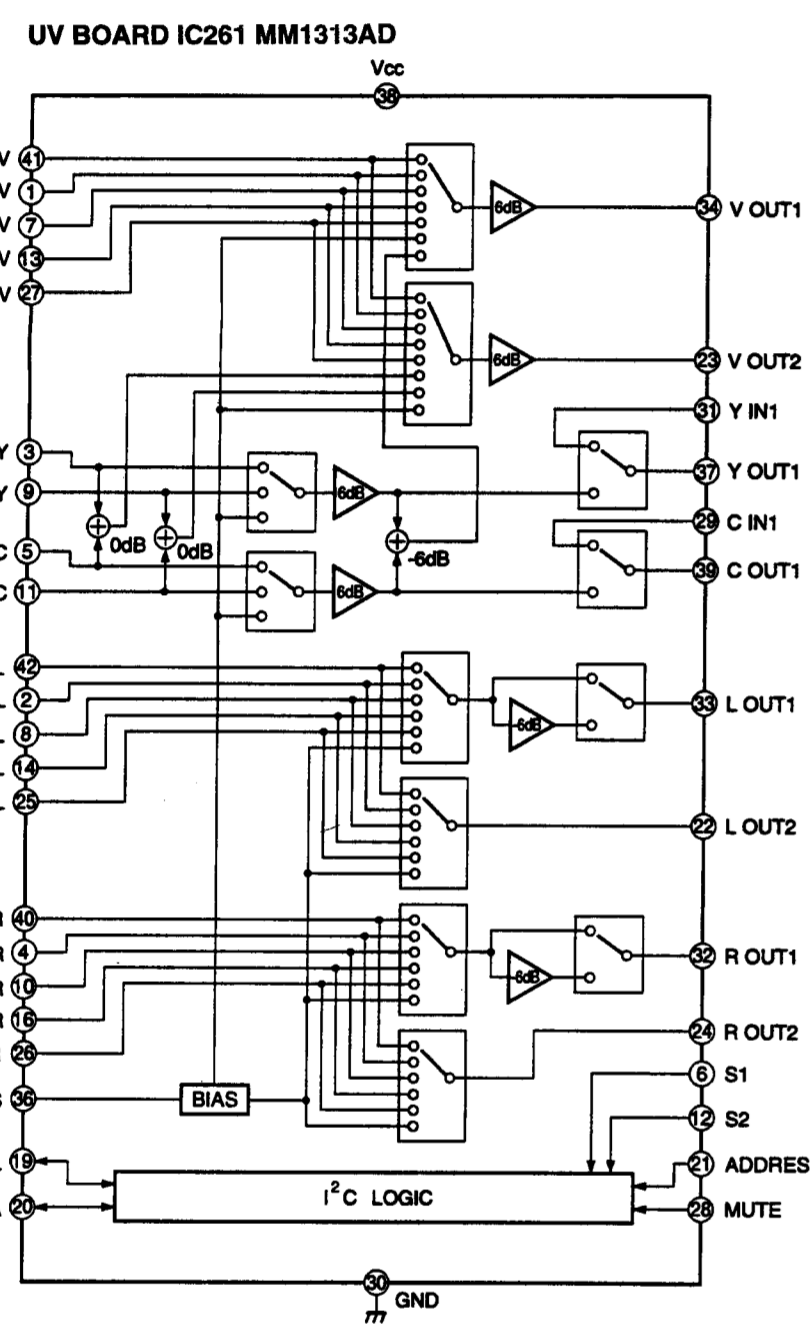
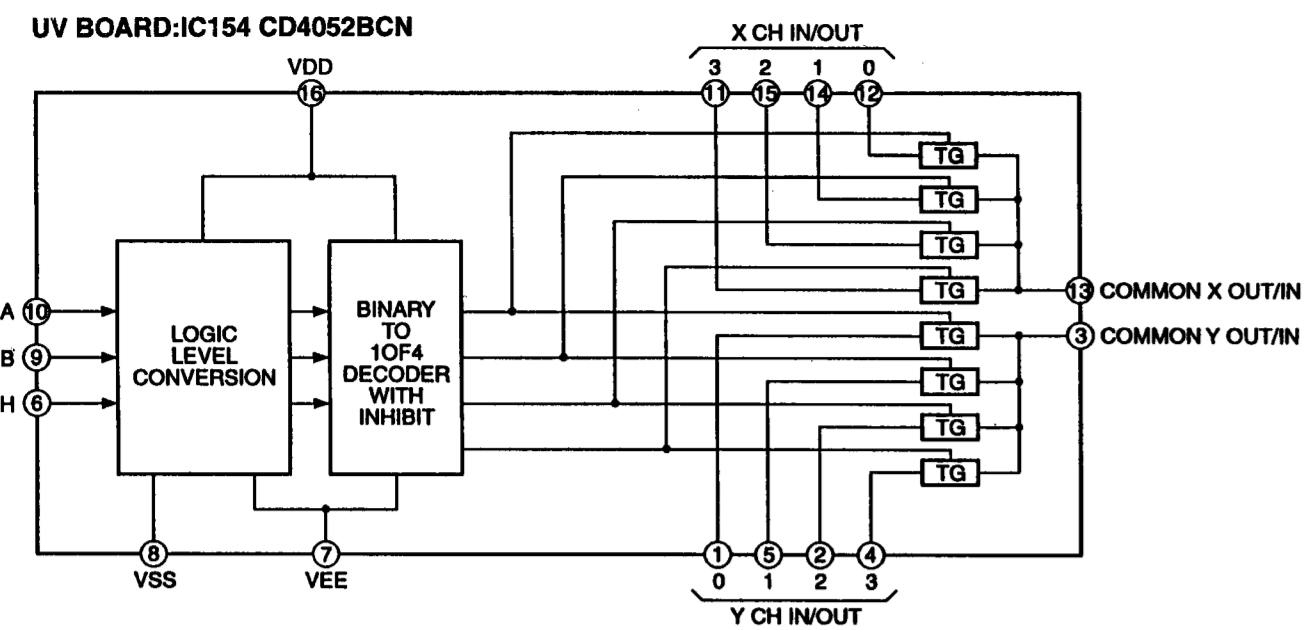

UV BOARD TRANSISTOR VOLTAGE LIST

Q	B	C	E
Q231	0	5.7	GND
Q232	0.2	4.9	GND
Q233	0	0	GND
Q234	0	0	GND
Q235	0	0	GND
Q236	0	0	GND
Q237	5.0	GND	5.7
Q238	4.1	GND	4.7
Q239	4.1	GND	4.7
Q240	4.4	GND	5.0
Q241	4.4	GND	5.0
Q242	4.3	GND	4.9
Q243	0.2	GND	0.9
Q261	4.6	8.7	4.0
Q282	4.9	5.7	4.2
Q283	3.4	GND	4.1
Q285	4.3	GND	4.9

All voltages are in V

UV BOARD IC VOLTAGE LIST

IC	pin	volt	pin	volt
IC151	1	4.4	12	4.4
	2	4.4	13	4.4
	3	4.4	14	4.4
	4	8.7	15	4.4
	5	4.4	16	8.7
	6	4.4	17	4.8
	7	4.4	2	4.2
	8	4.4	3	4.8
	9	4.4	4	4.2
	10	4.4	5	4.8
	11	GND	6	4.5
	12	4.4	7	4.8
	13	4.4	8	4.2
	14	4.4	9	4.8
IC261	1	4.4	10	4.2
	2	4.4	11	4.9
	3	4.4	12	5.8
	4	8.7	13	4.8
	5	4.4	14	4.2
	6	4.4	15	0
	7	4.4	16	4.2
	8	4.4	17	5.8
	9	4.4	18	NC
	10	4.4	19	5.0
	11	GND	20	4.9
IC152	1	4.4	21	GND
	2	4.4	22	NC
	3	4.4	23	NC
	4	GND	24	4.2
	5	4.4	25	4.2
	6	4.4	26	4.2
	7	4.4	27	5.1
	8	4.4	28	NC
	9	4.4	29	4.8
	10	4.4	30	GND
	11	8.7	31	5.8
IC153	1	4.4	32	4.1
	2	4.4	33	4.1
	3	4.4	34	5.0
	4	4.4	35	NC
	5	4.4	36	4.2
	6	GND	37	4.3
	7	GND	38	5.7
	8	GND	39	3.4
	9	0.5	40	4.2
	10	0.5	41	5.2
	11	4.4	42	4.2
IC154	1	4.4	43	4.2
	2	4.4	44	4.2
	3	4.4	45	4.2
	4	4.4	46	4.2
	5	4.4	47	4.2
	6	GND	48	4.3
	7	GND	49	4.3
	8	GND	50	3.4
	9	0.5	51	4.2
	10	0.5	52	4.2
	11	4.4	53	4.2

All voltages are in V

UV BOARD

Component	Value	Notes
C245	-	470 25V
C246	-	0.7
C247	-	0.47
C301	-	1
D239	-	MTZJ-1-77-3.3
D246	-	MTZJ-1-77-3.3
D248	-	MTZJ-1-77-3.3
J235	-	0
Q232	-	2SD601A-Q
Q235	-	2SD601A-Q
Q236	-	2SD601A-Q
Q240	-	2SB709A
Q241	-	2SB709A
Q242	-	2SB709A
R206	-	1K
R207	-	0
R208	-	1K
R209	-	6.8K
R210	-	6.8K
R219	-	4.7K
R220	-	4.7K
R221	-	470
R222	-	100
R223	-	100
R224	-	100
R252	-	56
R253	-	470K
R254	-	470K
R255	-	470K
R256	-	6.8K
R278	-	470

NOT MOUNTED

UV BOARD WAVEFORMS

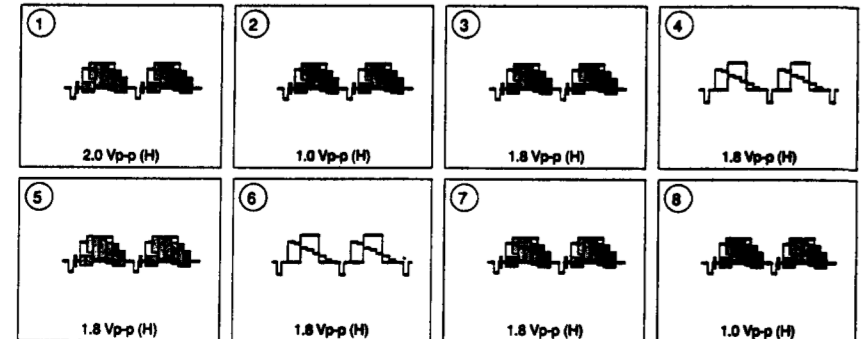

Schematic diagrams

← board UV board →

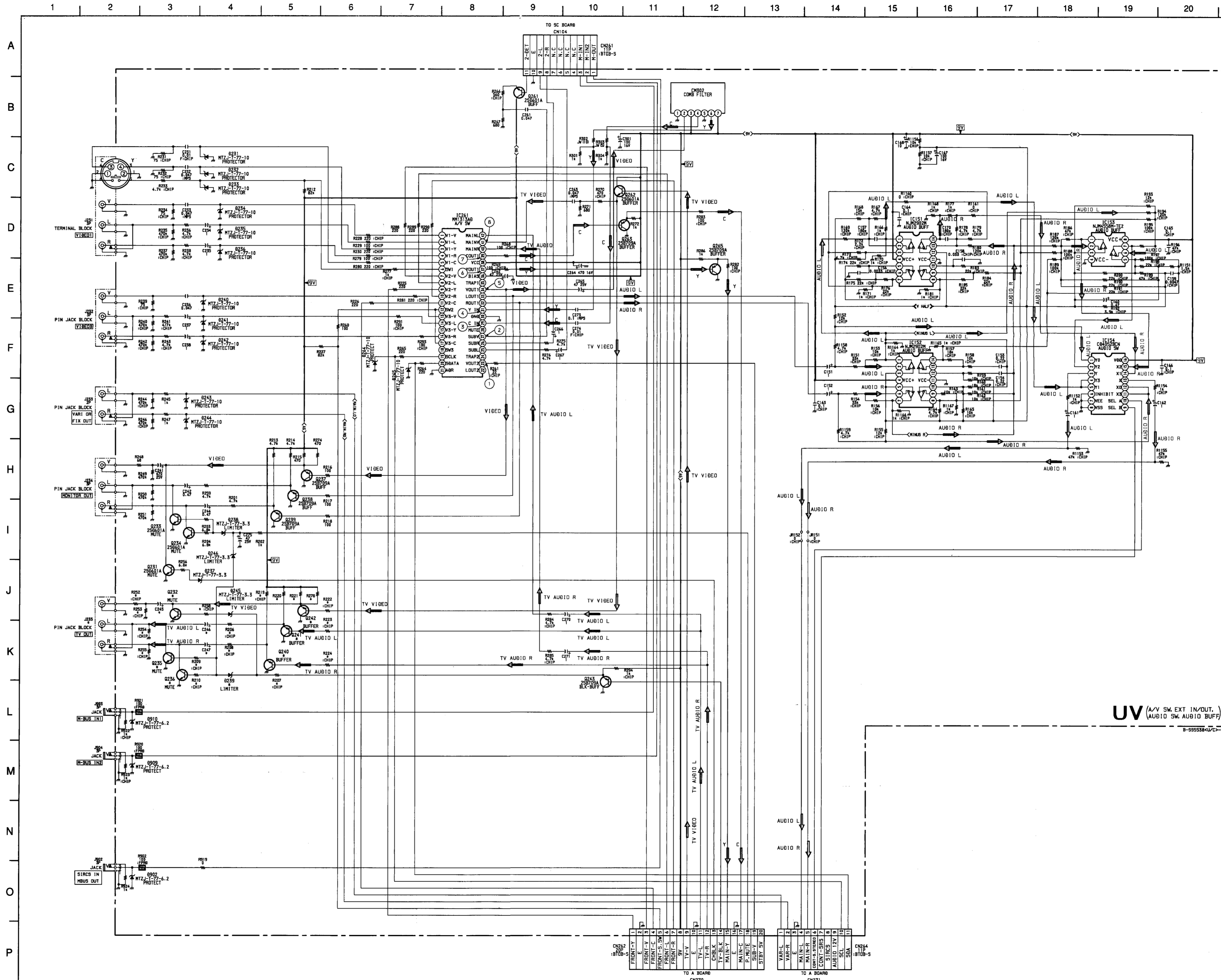

UV (A/V SW EXT IN/OUT.)
(AUDIO SW AUDIO BUFF)

B-99598-UC-UV

UV[AV SW, EXT IN/OUT,
AUDIO SW, AUDIO BUFF]

- UV BOARD -

1 2 3 4 5 6

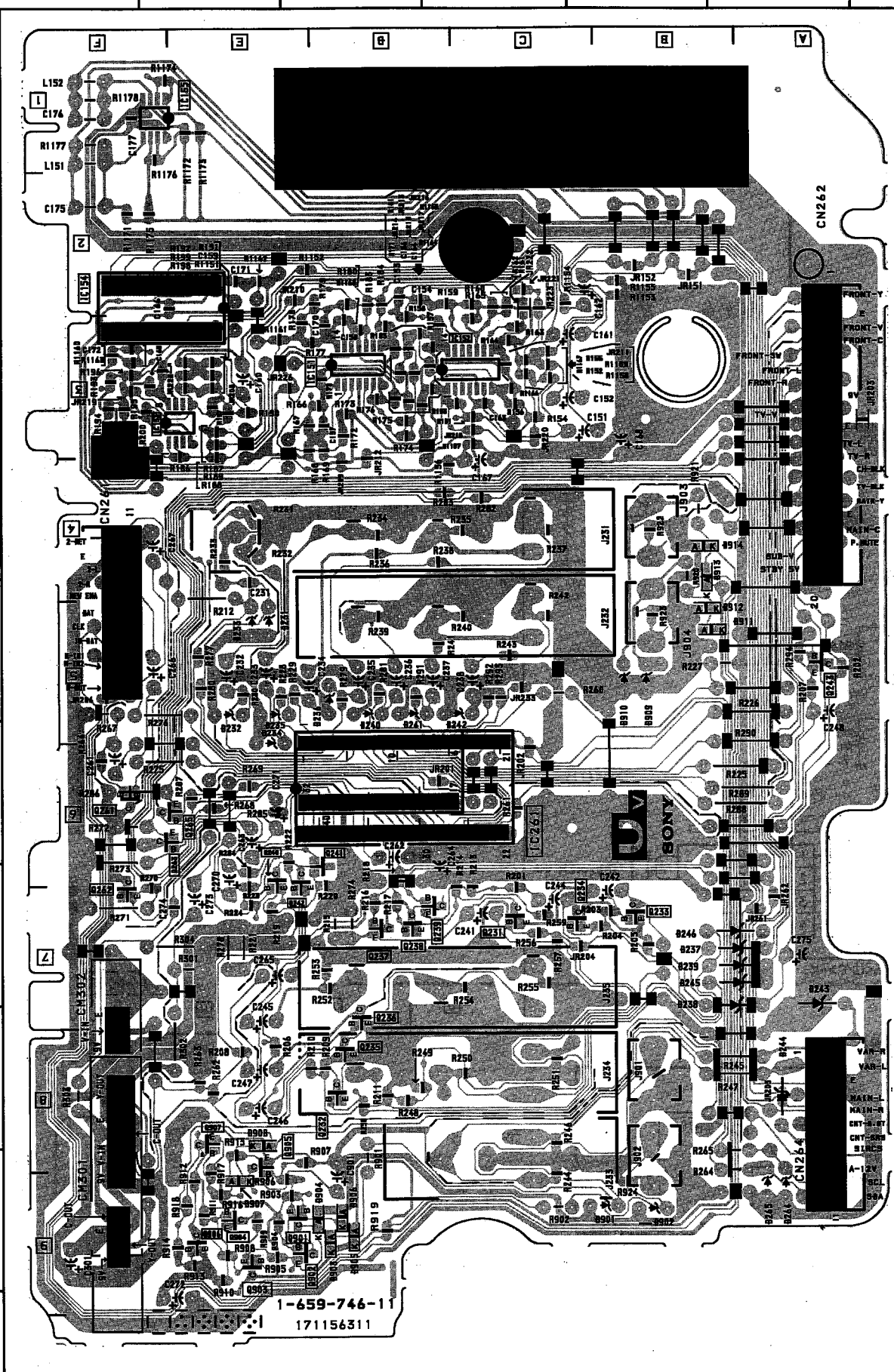
A
B
C
D
E
F
G
H
I
J1-659-746-11
171156311**UV BOARD**

DIODE	
D231	E-2
D232	E-2
D233	E-2
D234	F-2
D235	E-2
D236	E-3
D237	G-6
D238	G-6
D239	G-6
D240	E-3
D241	E-3
D242	E-4
D243	G-6
D244	H-6
D245	G-6
D246	G-6
D264	I-6
D265	I-6
D902	I-5
D909	E-5
D910	E-5

IC	
IC151	C-3
IC152	C-4
IC153	C-2
IC154	C-2
IC261	F-4

TRANSISTOR	
Q231	G-4
Q232	H-3
Q233	G-5
Q234	G-5
Q235	H-3
Q236	H-3
Q237	G-3
Q238	G-3
Q239	G-4
Q240	G-2
Q241	G-3
Q242	G-3
Q243	E-6
Q261	F-1
Q262	G-1
Q263	F-2
Q265	F-2

A
B
C
D
E
F
G
H
I

UV BOARD

DIODE	
D231	E-2
D232	E-2
D233	E-2
D234	F-2
D235	E-2
D236	E-3
D237	G-6
D238	G-6
D239	G-6
D240	E-3
D241	E-3
D242	E-4
D243	G-6
D244	H-6
D245	G-6
D246	G-6
D264	I-6
D265	I-6
D902	I-5
D909	E-5
D910	E-5

IC	
IC151	C-3
IC152	C-4
IC153	C-2
IC154	C-2
IC261	F-4

TRANSISTOR	
Q231	G-4
Q232	H-3
Q233	G-5
Q234	G-5
Q235	H-3
Q236	H-3
Q237	G-3
Q238	G-3
Q239	G-4
Q240	G-2
Q241	G-3
Q242	G-3
Q243	E-6
Q261	F-1
Q262	G-1
Q263	F-2
Q265	F-2

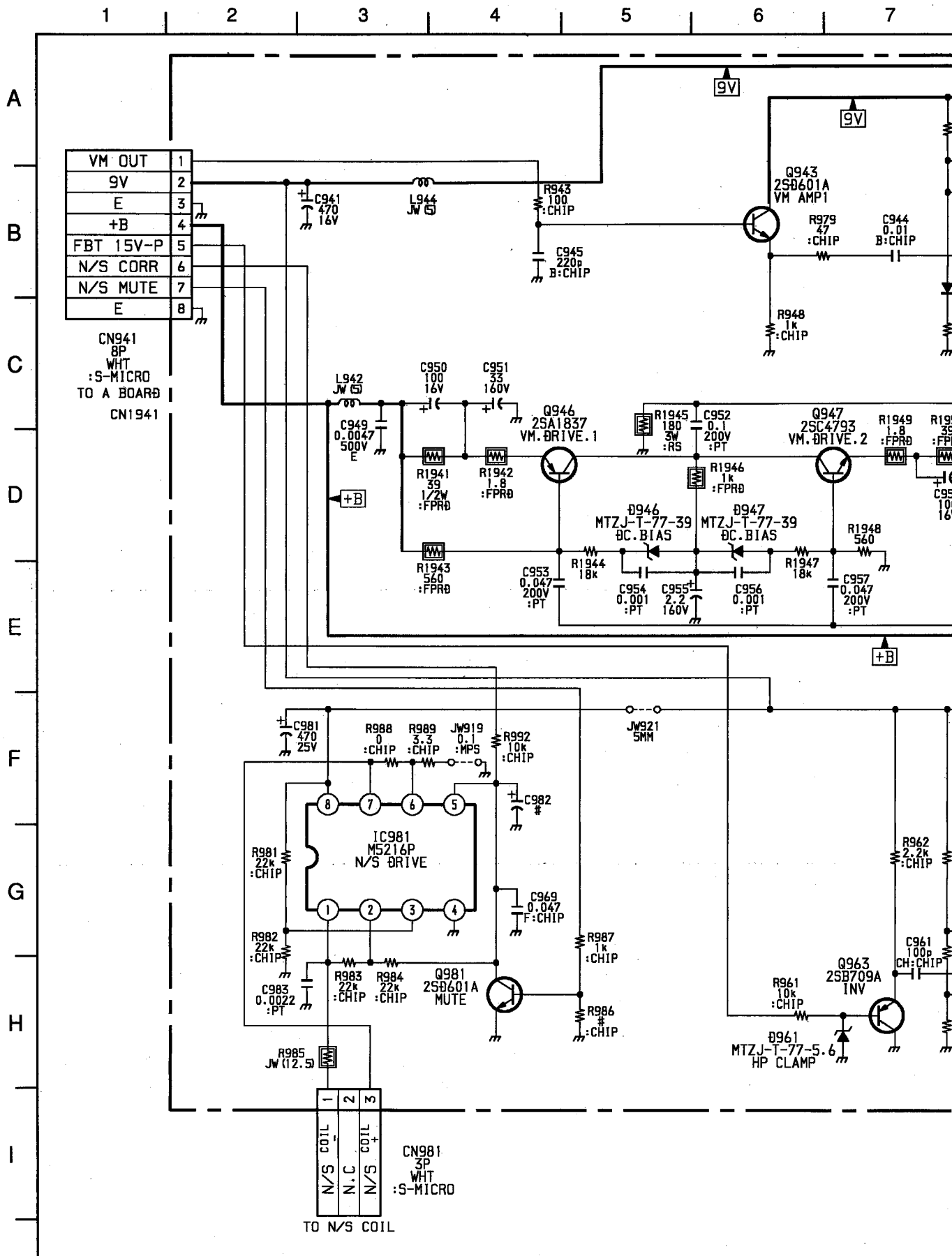

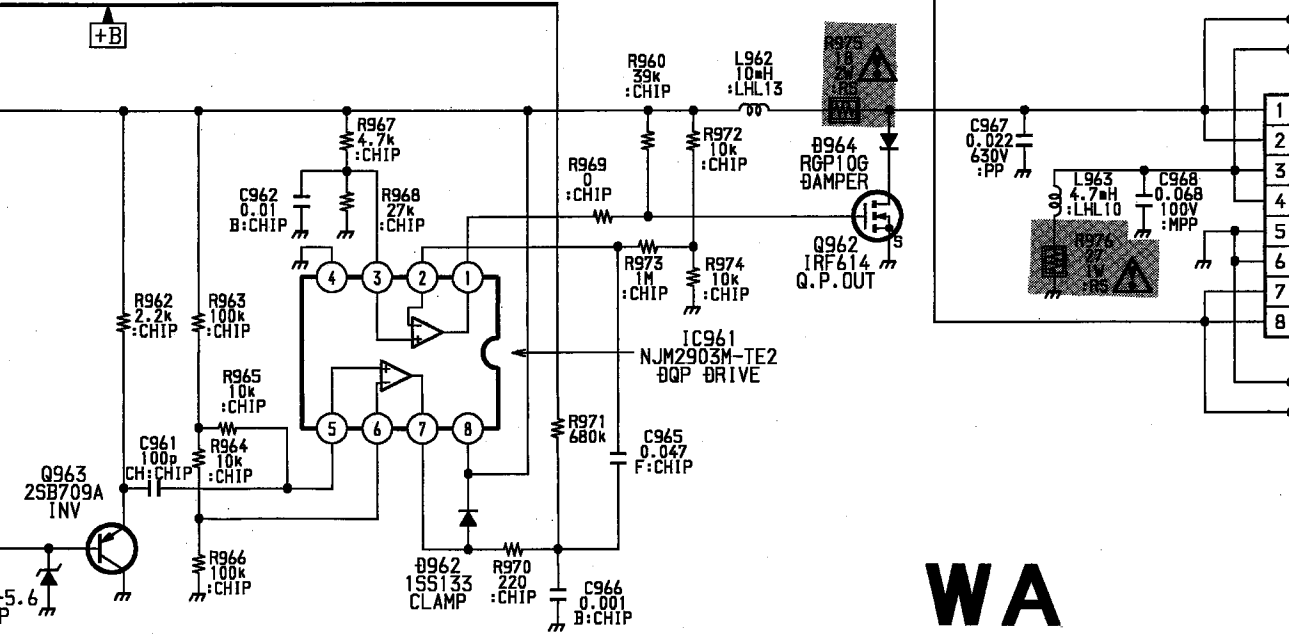
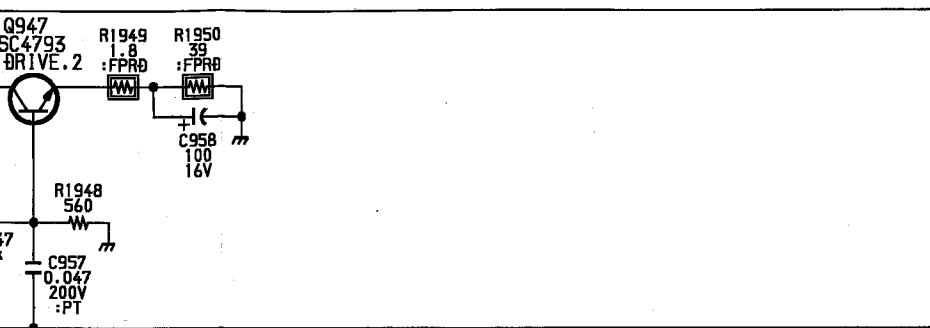
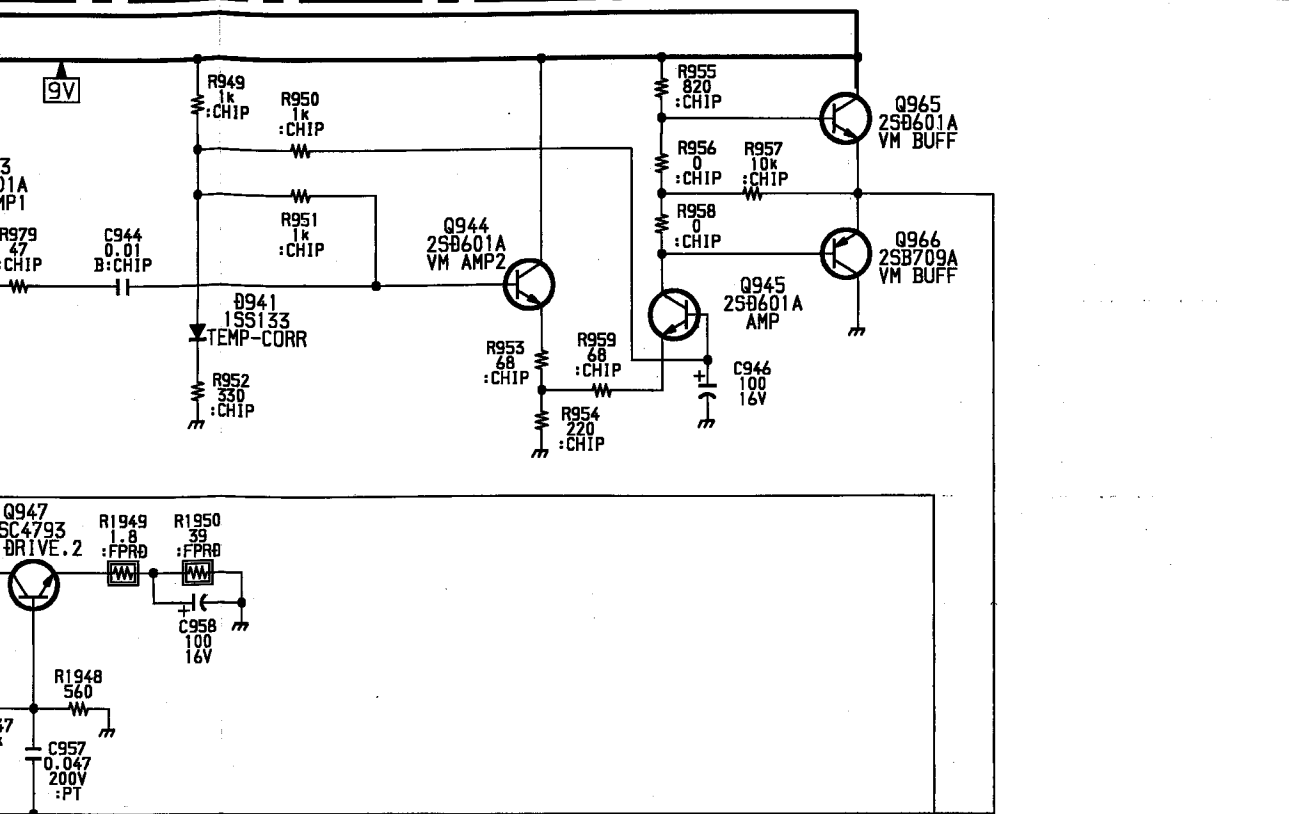

WA BOARD TRANS

	B	
Q943	3.0	
Q944	2.7	
Q945	2.7	
Q946	134.0	
Q947	0.9	
Q963	4.6	
Q965	5.5	
Q966	5.5	
Q981	0	
	G	
Q962	4.3	

WA BOARD IC VOL

	pin	volt		pin	volt
IC961	1	4.3	IC981	1	4.3
	2	4.1		2	4.1
	3	7.5		3	7.5
	4	GND		4	GND
	5	4.6		5	4.6
	6	4.2		6	4.2
	7	4.4		7	4.4
	8	8.7		8	8.7

All voltages in Volts

WA

(VELOCITY MOD, QUAD POLE, ROTATION)

B-SS5538<U/C>-WA.

- WA BOARD -

BOARD TRANSISTOR VOLTAGE LIST

	B	C	E
3	3.0	8.7	2.4
4	2.7	8.7	2.1
5	2.7	5.5	2.1
6	134.0	65.7	134.6
7	0.9	65.7	0.5
8	4.6	GND	5.3
9	5.5	8.7	5.5
10	5.5	GND	5.5
11	0	4.1	GND
12	G	D	S
13	4.3	9.8	GND

All voltages are in V

BOARD IC VOLTAGE LIST

pin	volt	IC981	pin	volt
1	4.3		1	4.8
2	4.1		2	4.5
3	7.5		3	4.4
4	GND		4	GND
5	4.6		5	4.1
6	4.2		6	4.1
7	4.4		7	4.1
8	8.7		8	8.7

All voltages are in V

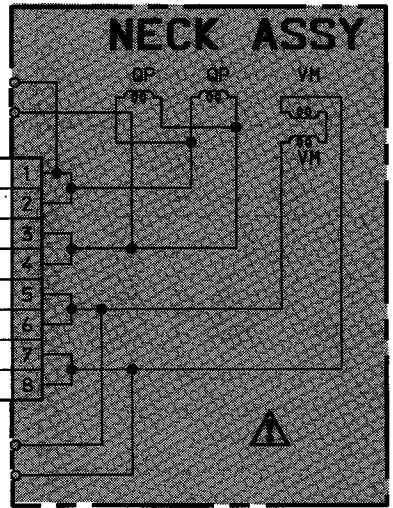
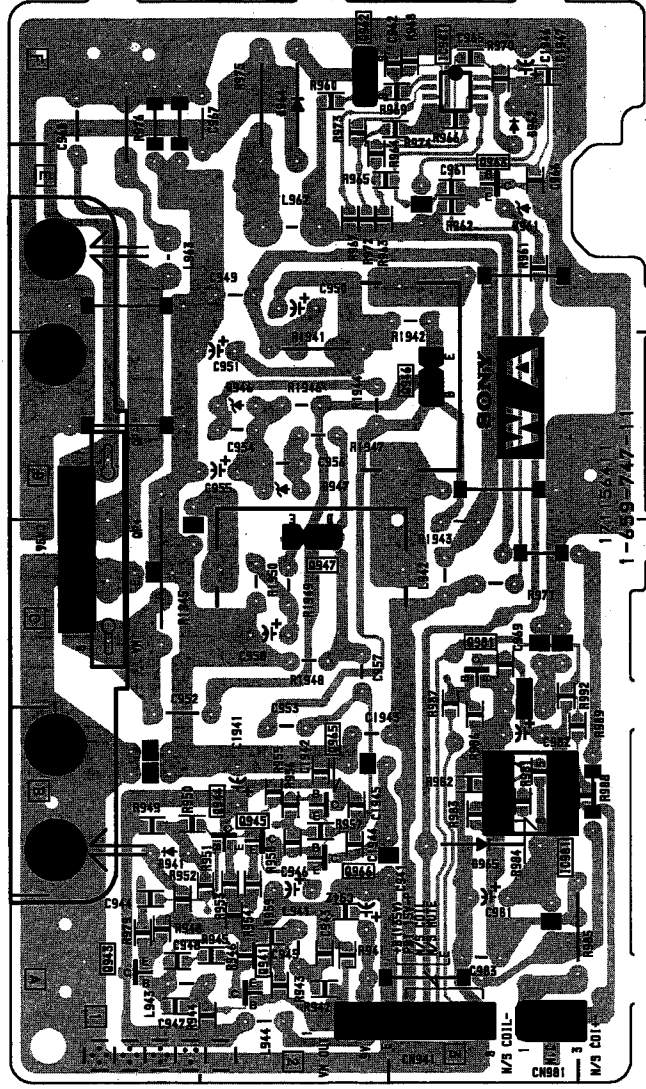

WA BOARD:IC981 M5216P

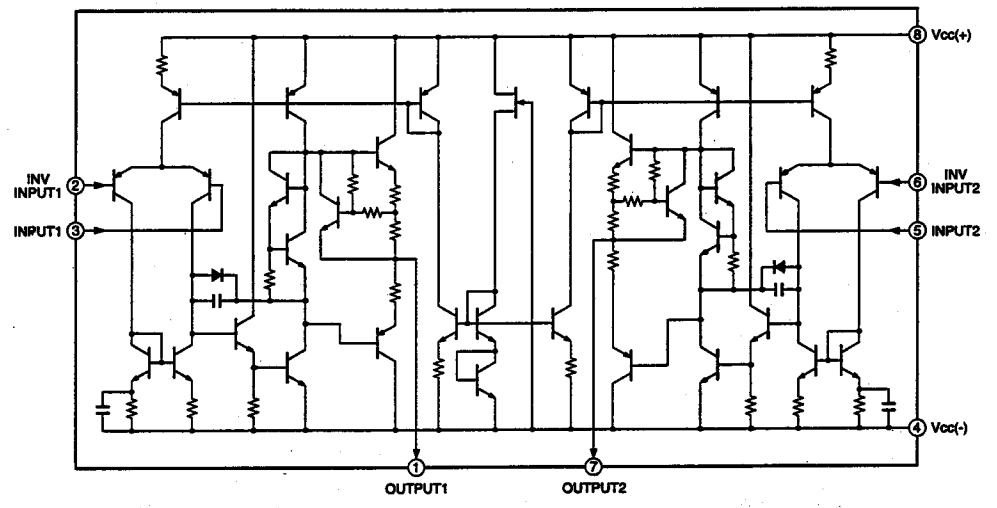

HV BOARD

	KV-35V35	KV-35V45/V75
C2231	-	0.01
C2232	-	0.047
CN2002	-	3P
D2231	-	MTZJ-T-77-10
D2232	-	MTZJ-T-77-10
D2233	-	MTZJ-T-77-10
J2232	-	S-JACK
R2059	820	-
R2060	1K	-
R2061	1.8K	-
R2062	4.7K	-
R2063	10K	-
R2231	-	75
R2232	-	75
R2233	-	4.7K
S2001	TACTILE-SW	-
S2002	TACTILE-SW	-
S2003	TACTILE-SW	-
S2004	TACTILE-SW	-
S2005	TACTILE-SW	-
S2006	TACTILE-SW	-
S2007	TACTILE-SW	-

A
B
C
D
E
F
G

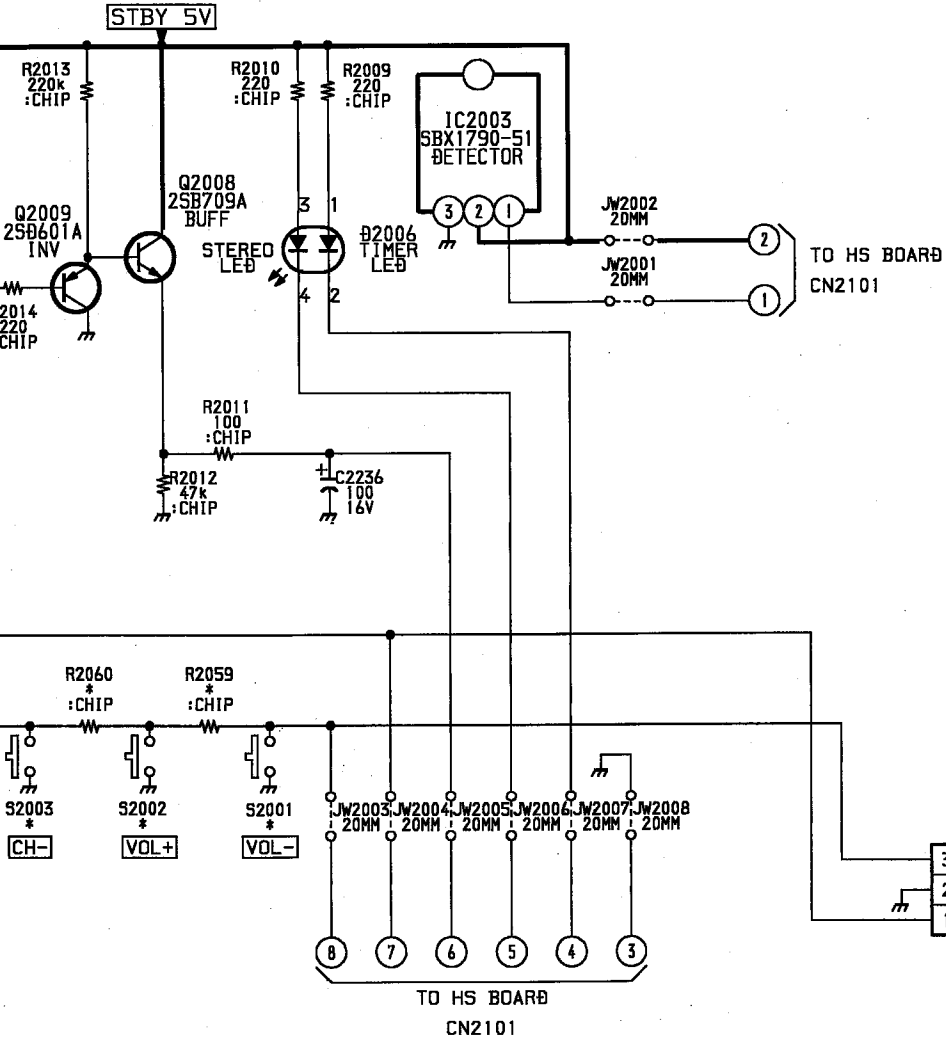

B-S55538<U/C>-HV.

CN1461
7P
WHT
:S-MICRO
TO A BOARD
CN461

E	1
R	2
E	3
L	4
AUDIO +B	5
AUDIO +B	6
MUTE	7

HV BOARD TRANSISTOR VOLTAGE LIST

	B	C	E
Q2008	4.5	5.0	1.5
Q2009	0.4	GND	4.5

All voltages are in V

HV BOARD IC VOLTAGE LIST

	pin	volt
IC2003	1	5.0
	2	5.0
	3	GND
IC2004	1	5.0
	2	0.5
	3	GND
	4	NC

All voltages are in V

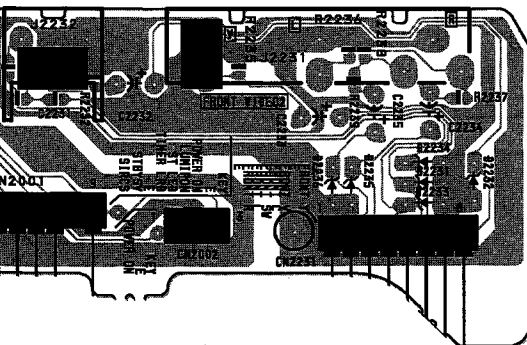

K (AUDIO AMP)
KV-35V45/35V75 ONLY

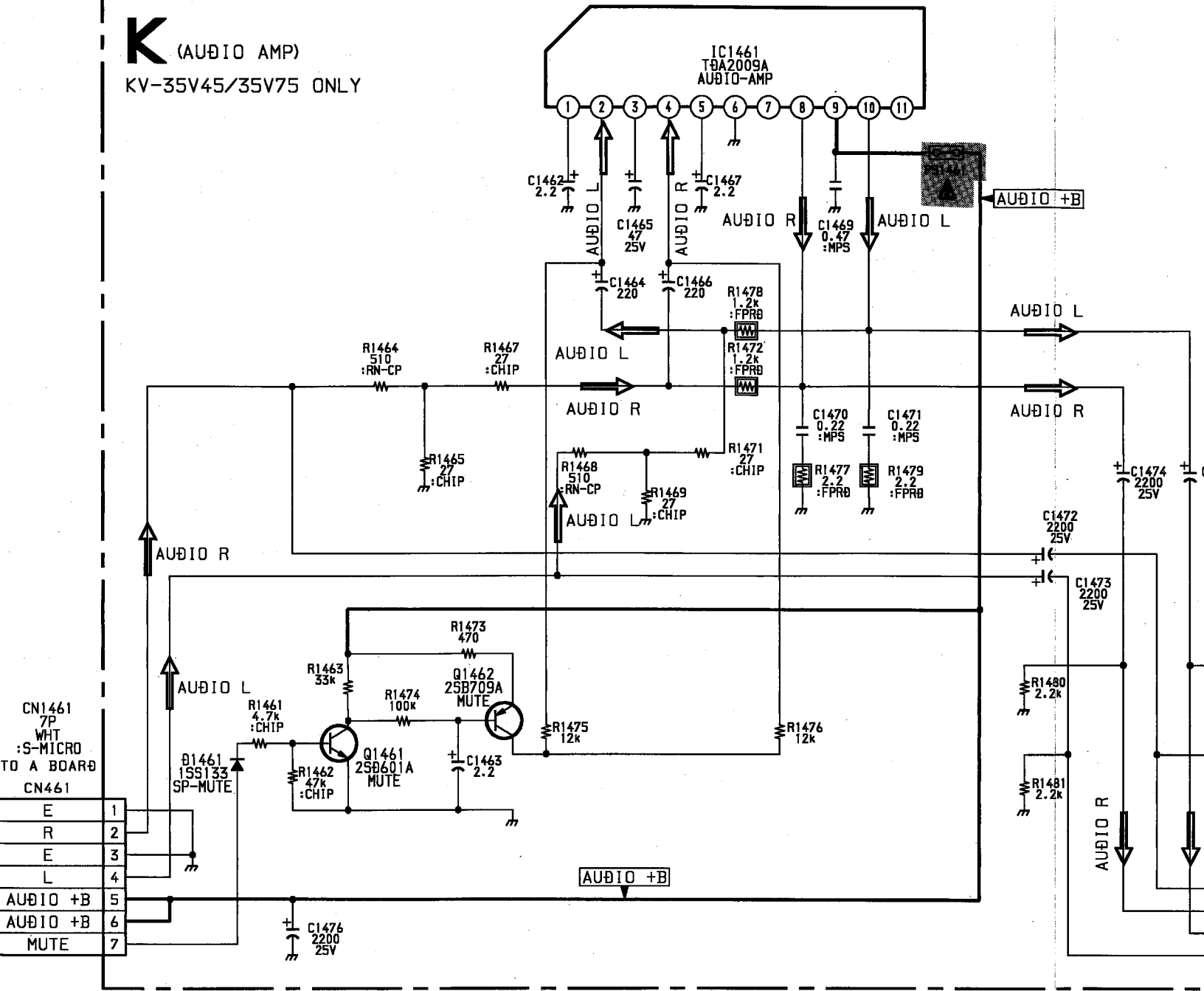

CN1461
7P
WHT
:S-MICRO
TO A BOARD
CN461

E	1
R	2
E	3
L	4
AUDIO +B	5
AUDIO +B	6
MUTE	7

B-SS55

K BOARD TRANSISTOR VOLTAGE LIST

	B	C	E
Q1461	0.7	0	GND
Q1462	20.0	20.7	20.7

All voltages are in V

K BOARD IC VOLTAGE LIST

IC1461	pin	volt
	1	1.5
	2	4.2
	3	12.2
	4	4.2
	5	1.5
	6	GND
	7	NC
	8	0.2
	9	22.1
	10	0.2
	11	NC

All voltages are in V

K BOARD:IC1461 TDA2009A

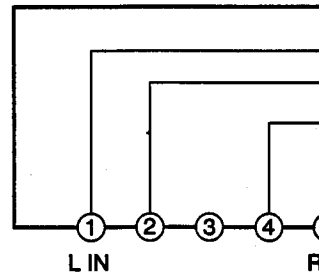

K [AUDIO AMP] (KV-35V45/75 ONLY)

- K BOARD -

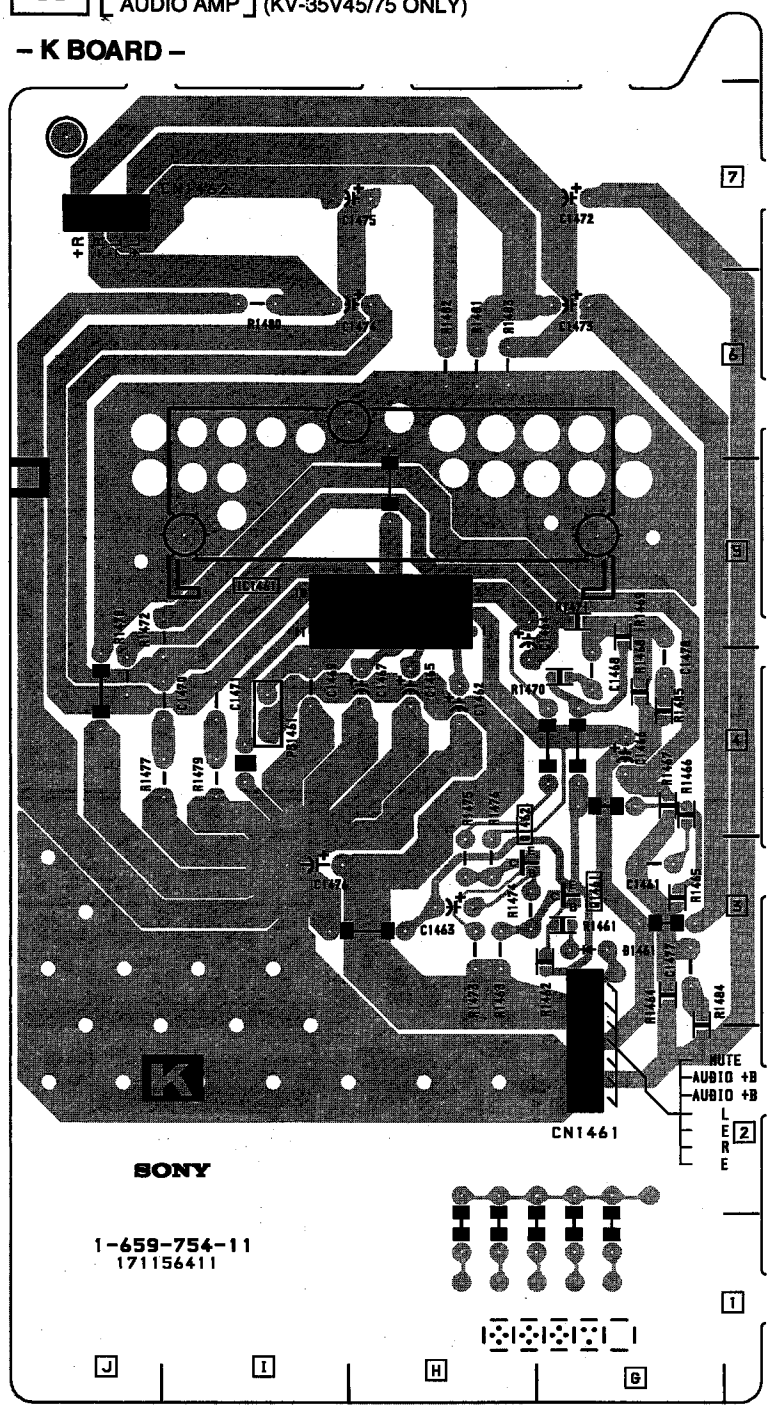
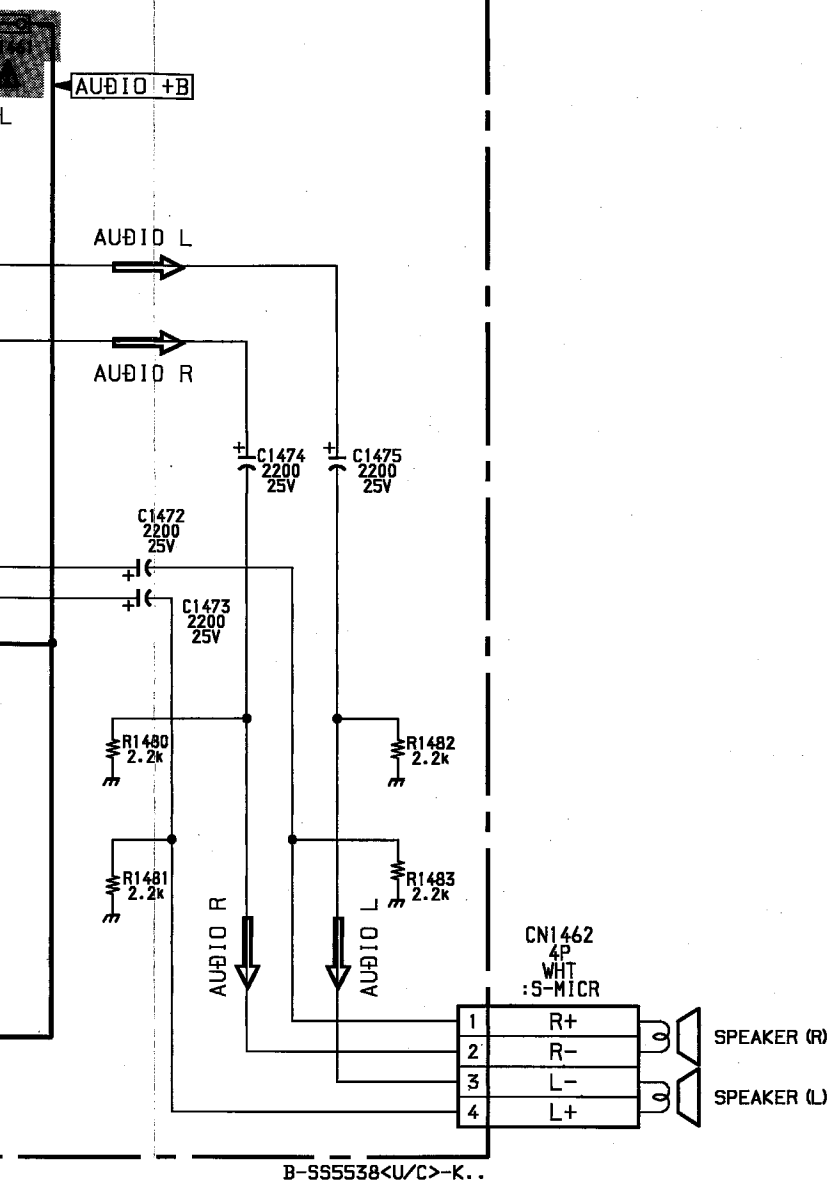

K BOARD:IC1461 TDA2009A

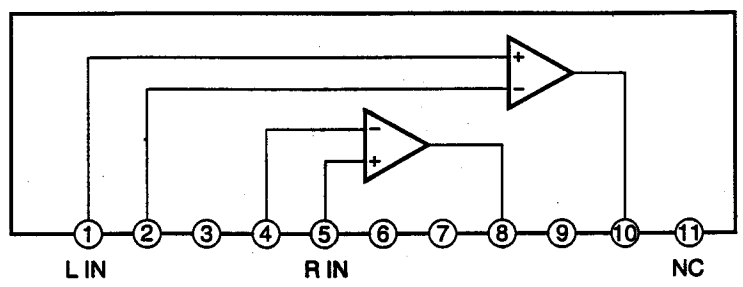

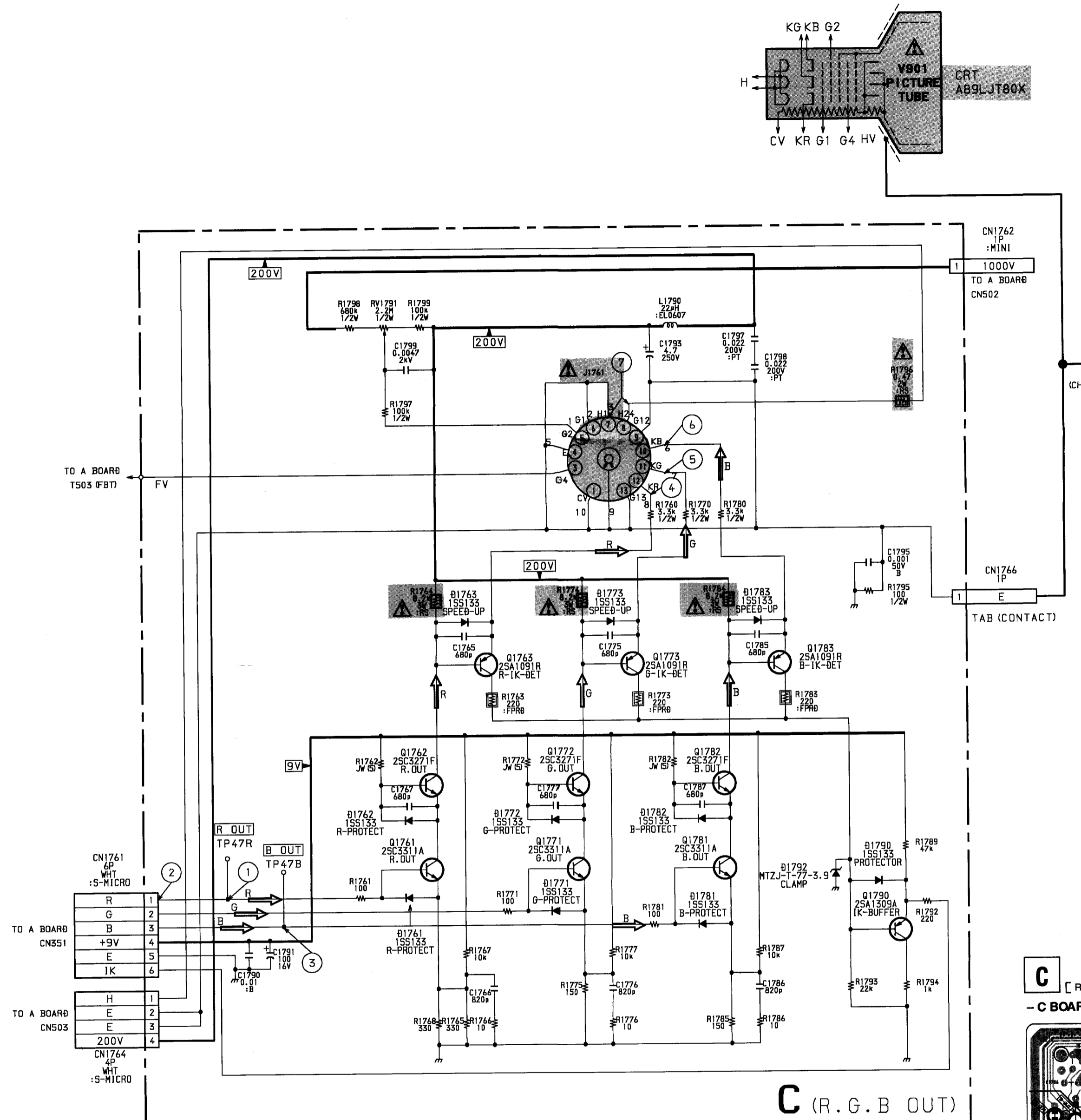

C BOARD TRANSISTOR VOLTAGE LIST

Q1761	B	C	E
Q1761	2.2	8.2	1.7
Q1762	8.7	134.1	8.2
Q1763	134.1	2.3	132.0
Q1771	1.8	8.2	1.3
Q1772	8.7	146.4	8.2
Q1773	146.4	2.3	144.1
Q1781	2.1	8.2	1.6
Q1782	8.7	133.7	8.2
Q1783	133.7	2.3	131.5
Q1790	2.2	0.2	2.5

All voltages are in V

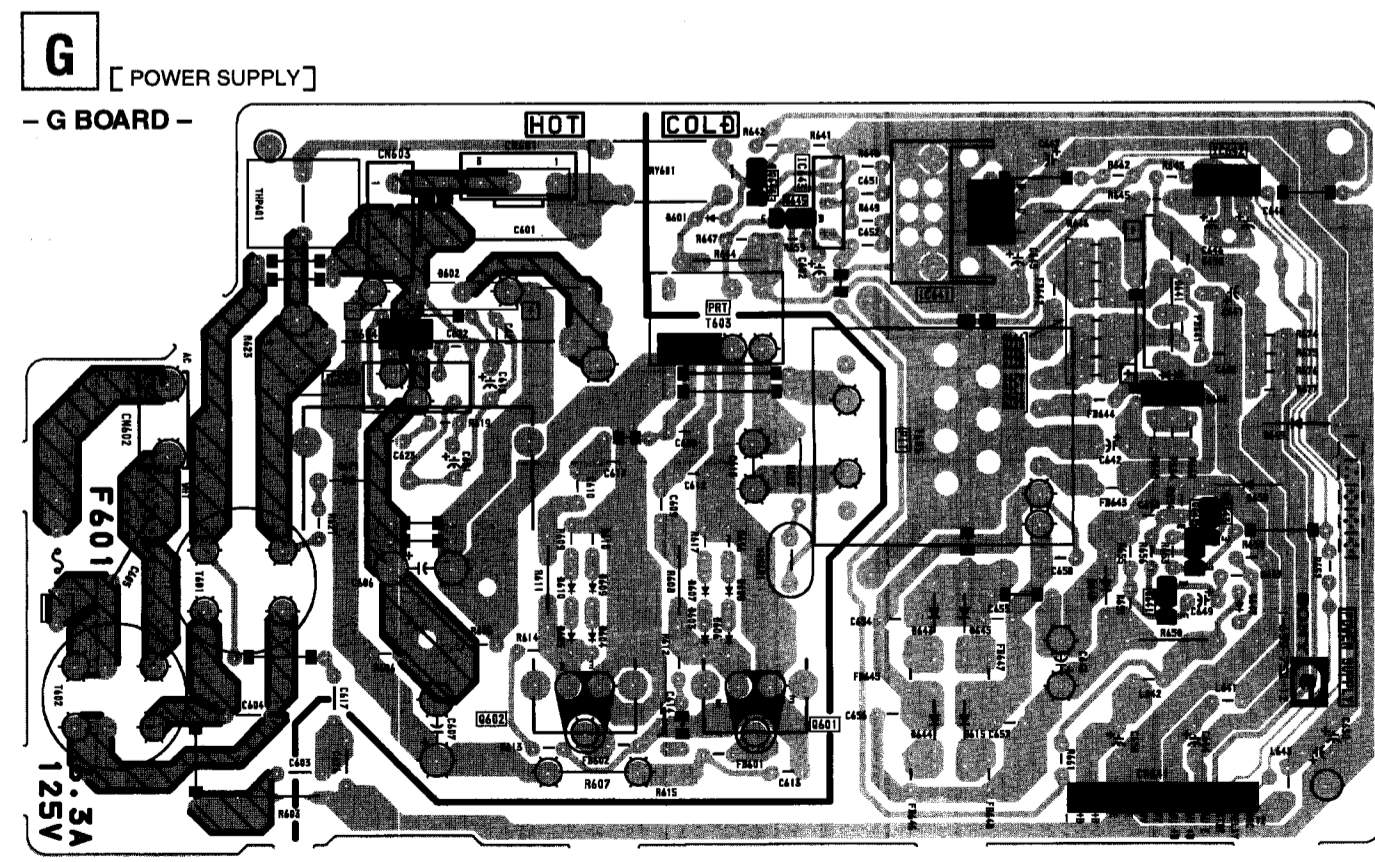
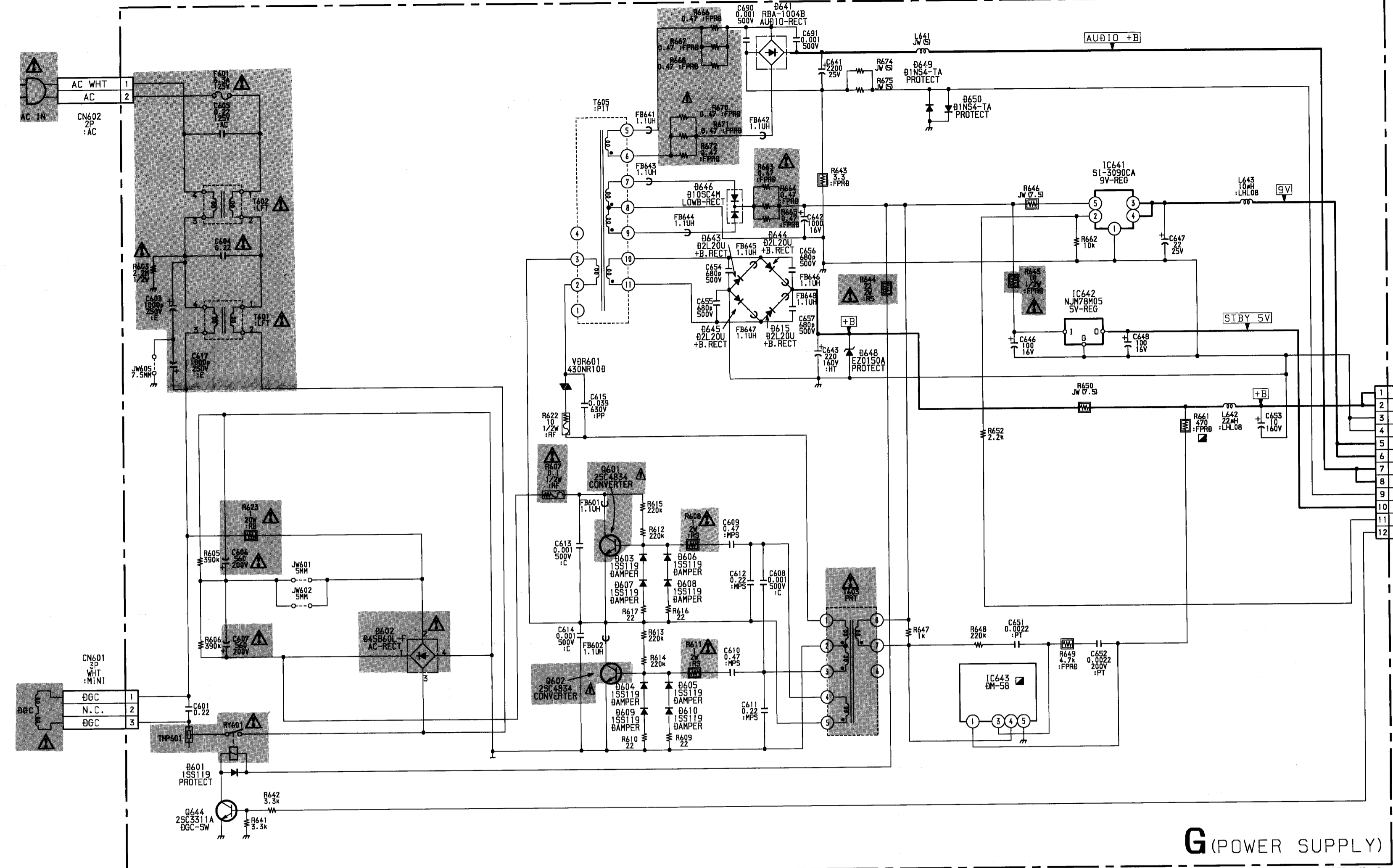
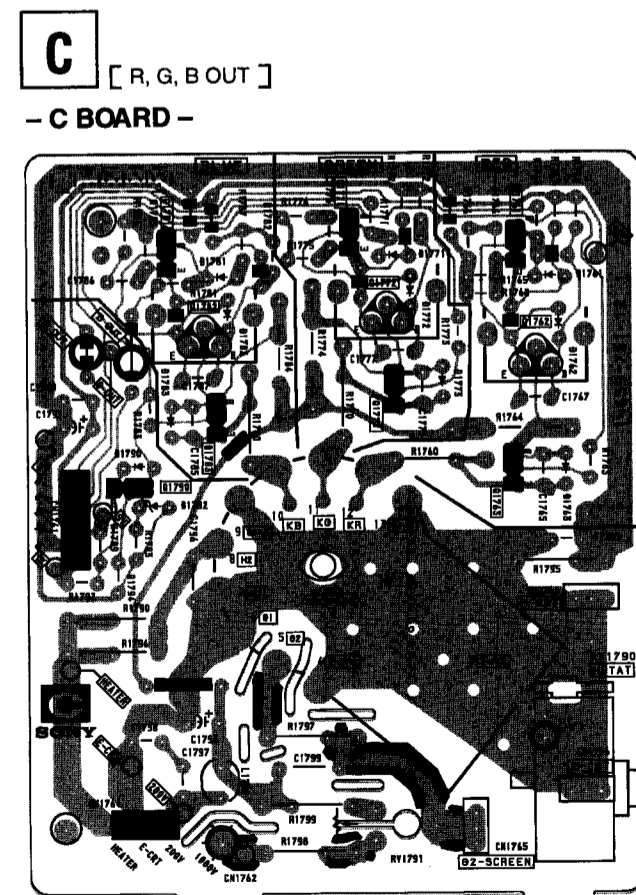
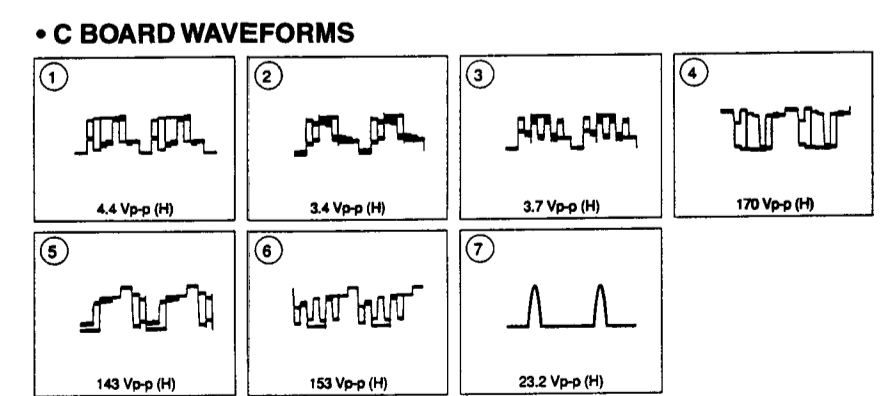

G BOARD TRANSISTOR VOLTAGE LIST

Q601	B	C	E
Q601	145.2	294.0	147.5
Q602	-1.7	147.5	GND
Q644	0	10.5	GND

All voltages are in V

G BOARD IC VOLTAGE LIST

IC	pin	volt
IC641	1	GND
	2	3.9
	3	8.9
	4	8.9
	5	10.5
IC642	IN	9.5
	OUT	5.0
IC643	1	135
	2	NC
	3	2.5
	4	7.8
	5	GND

All voltages are in V

4-4. SEMICONDUCTORS

BH3856FS-E2

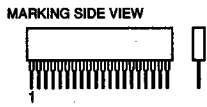

32pin SIP

CD4052BCN



16pin DIP

CXA1315M

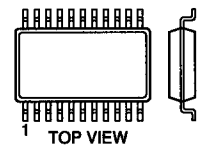

16pin SOP

CXA2025S

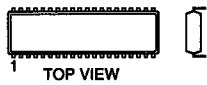

48pin DIP

CXP85640-004S

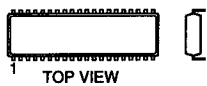

64pin DIP

DM-58

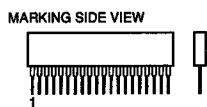

4pin SIP

IS474

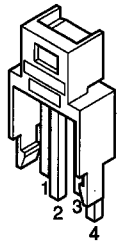

LM2901M

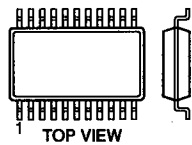

14pin SOP

M5216P



8pin DIP

MM1313AD



42pin DIP

NJM2129M-TE2

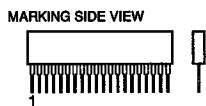

14pin SIP

NJM2902M

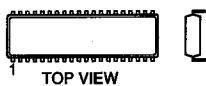

14pin DIP

NJM2903M
NJM2904M
ST24C02FM6TR
UPC4558G2

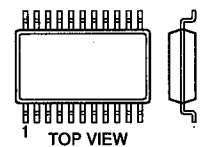

8pin SOP

NJM78M05FA
TA7805S

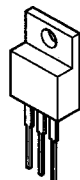

SBX1790-51

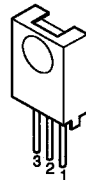

SDA9288X

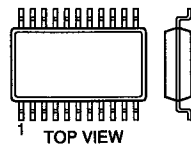

32pin SOP

S13090CA

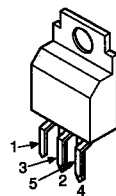

STV9379

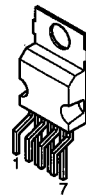

TDA2009A

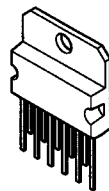

TDA8315T/N3A-T

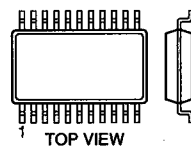

24pin SOP

IRF614



2SA1037AK-T146-R

2SA1162-G

2SA1330-06

2SC1623-L5L6

2SD601A-Q

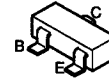

2SA1091-0



2SA1175-HFE

2SC2785-HFE

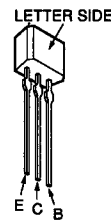

2SA1837

2SC4159-E

2SC4793

2SC5148

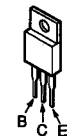

2SC2611

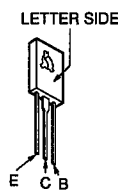

2SC4834M



2SD774-34

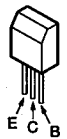

D10SC4M

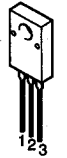

D1NS4

MTZJ-3.3

MTZJ-33A

MTZJ-6.2B

MTZJ-7.5B

RD3.3ES-B2

RD3.9ES-B2

RD33ESB1

RD39ES-B2

RD4.3ES-B3

RD5.6ESB2

RD5.6ESB3

RD6.2ESB2

RD7.5ESB2

1SS119-25

1SS133T-77

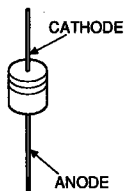

2SC2611

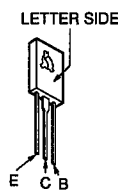

2SC4834M



D2L20U

EGP20G

EL1Z

EZ0150AV1

GP08D

MTZJ-T-77-3.9

MTZJ-T-77-4.3C

RGP02-17EL-6433

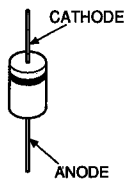

5-2. PICTURE TUBE

- : 7-685-648-79 +BVTP 3X12
- : 7-685-663-79 +BVTP 4X16

The components identified by shading and mark **▲** are critical for safety. Replace only with part number specified.

Les composants identifiés par une trame et une marque **▲** sont critiques pour la sécurité. Ne les remplacer que par une pièce portant le numéro spécifié.

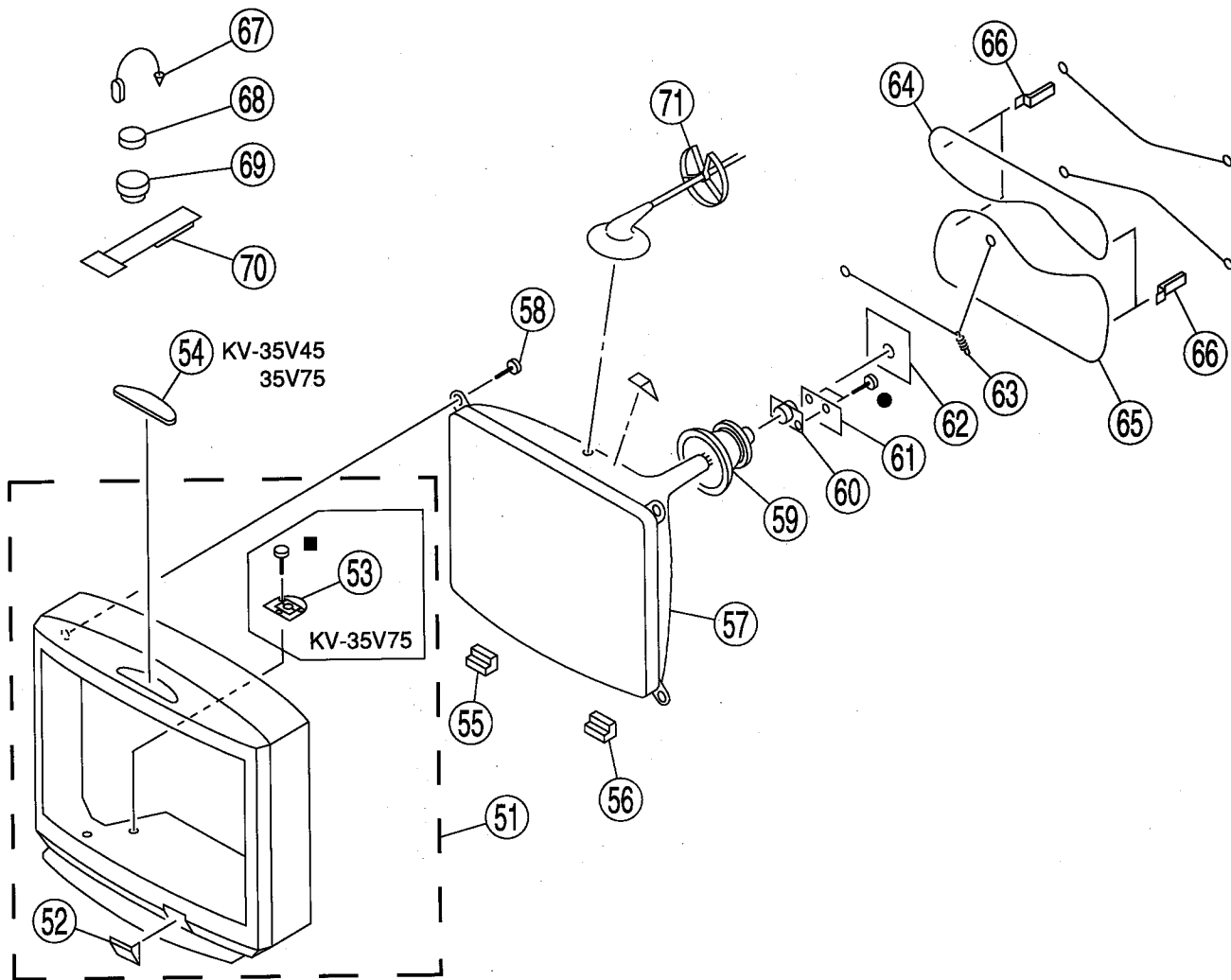

REF. NO.	PART NO.	DESCRIPTION	REMARK	REF. NO.	PART NO.	DESCRIPTION	REMARK
51	X-4033-456-1	BEZNET ASSY (KV-35V35)	52	60	8-453-007-11	NA324-M	
51	X-4033-457-1	BEZNET ASSY (KV-35V75)	52,53	61	* A-1372-211-A	WA BOARD, COMPLETE	
51	X-4033-458-1	BEZNET ASSY (KV-35V45)	52	62	* A-1331-522-A	C BOARD, COMPLETE	
52	4-052-906-01	DOOR, CONTROL (KV-35V35)		63	4-036-329-01	SPRING (B), TENSION	
52	4-052-906-11	DOOR, CONTROL (KV-35V45/35V75)		64	1-411-881-11	COIL, DEMAGNETIC	
53	X-4032-889-1	CLAMP ASSY (KV-35V75)		65	1-411-882-11	COIL, DEMAGNETIC	
54	1-473-549-11	SWITCH BLOCK, CONTROL (KV-35V45/35V75)		66	* 4-052-900-01	HOLDER, DGC	
55	4-052-902-01	SUPPORT (L), PICTURE TUBE		67	4-308-870-00	CLIP, LEAD WIRE	
56	4-052-901-01	SUPPORT (R), PICTURE TUBE		68	1-452-032-00	MAGNET, DISK ; 10mmφ	
57	▲ 8-733-760-05	PICTURE TUBE SD-285 (A89LJT80X)		69	1-452-094-00	MAGNET, ROTATABLE DISK ; 15mmφ	
58	4-046-765-01	SCREW, TAPPING		70	X-4306-312-0	PERMALLOY ASSY, CONVERGENCE	
59	▲ 8-451-480-11	DEFLECTION YOKE (Y37GXA-X)		71	3-704-372-31	HOLDER, HV CABLE	

5-3. CABINET BASE (KV-35V75)

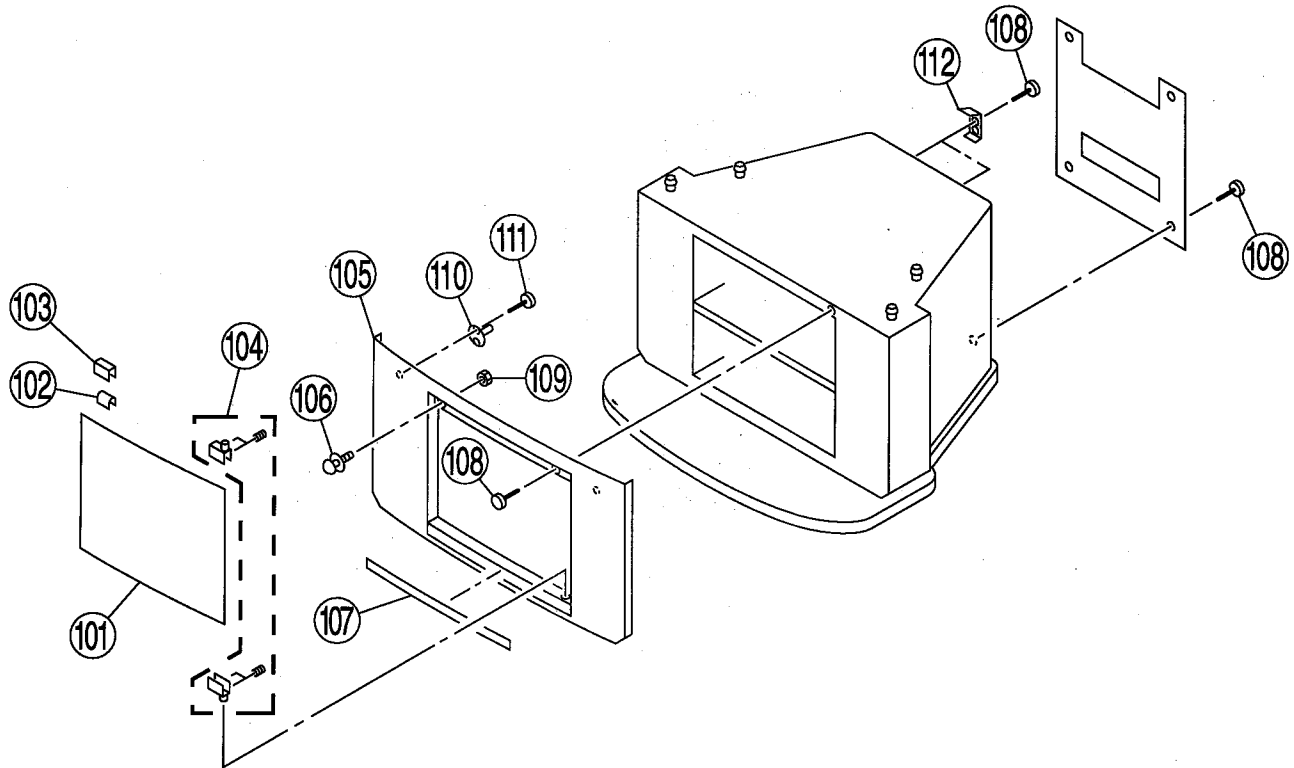

<u>REF. NO.</u>	<u>PART NO.</u>	<u>DESCRIPTION</u>	<u>REMARK</u>	<u>REF. NO.</u>	<u>PART NO.</u>	<u>DESCRIPTION</u>	<u>REMARK</u>
101	X-4033-459-1	DOOR ASSY, GLASS		107	* 4-052-919-01	PANEL, FRONT	
102	2-352-981-01	SPACER		108	4-041-164-11	SCREW (4X20), TAPPING	
103	2-359-505-01	RETAINER, MAGNET		109	4-046-172-01	NUT, HEXAGON HEAD	
104	4-049-536-01	HINGE SET		110	4-843-806-00	STRIKE	
105	4-052-922-01	COVER, FRONT		111	4-041-165-01	SCREW (3X12), TAPPING, +BV	
106	4-032-322-02	MAGNET, PUSH		112	4-049-530-01	BRACKET, REAR	



Les composants identifiés par une trame et une marque Δ sont critiques pour la sécurité. Ne les remplacer que par une pièce portant le numéro spécifique.

The components identified by shading and mark Δ are critical for safety. Replace only with part number specified.

REF. NO.	PART NO.	DESCRIPTION	REMARK
<TUNER>			
TU101	Δ 8-598-339-00	TUNER BTF-LA402	

* A-1297-719-A	A BOARD, COMPLETE (KV-35V35)		
* A-1297-721-A	A BOARD, COMPLETE (KV-35V45/35V75)		
2-106-573-11	SPACER		
* 4-051-927-01	CASE, SHIELD		
4-382-854-11	SCREW (M3X10), P, SW (+)		
<CAPACITOR>			
C001	1-163-125-00	CERAMIC CHIP 220PF	5% 50V
C003	1-104-760-11	CERAMIC CHIP 0.047MF	10% 50V
C005	1-124-903-11	ELECT 1MF	20% 50V
C009	1-126-967-11	ELECT 47MF	20% 50V
C010	1-163-033-91	CERAMIC CHIP 0.022MF	50V
C011	1-163-017-00	CERAMIC CHIP 0.0047MF	10% 50V
C012	1-164-005-11	CERAMIC CHIP 0.47MF	25V
C013	1-163-017-00	CERAMIC CHIP 0.0047MF	10% 50V
C023	1-163-125-00	CERAMIC CHIP 220PF	5% 50V
C028	1-163-227-11	CERAMIC CHIP 10PF	0.5PF 50V
C029	1-163-227-11	CERAMIC CHIP 10PF	0.5PF 50V
C030	1-163-009-11	CERAMIC CHIP 0.001MF	10% 50V
C035	1-163-237-11	CERAMIC CHIP 27PF	5% 50V
C036	1-163-231-11	CERAMIC CHIP 15PF	5% 50V
C051	1-164-161-11	CERAMIC CHIP 0.0022MF	10% 50V
C053	1-164-232-11	CERAMIC CHIP 0.01MF	10% 50V
C061	1-163-033-91	CERAMIC CHIP 0.022MF	50V
C062	1-163-033-91	CERAMIC CHIP 0.022MF	50V
C063	1-126-935-11	ELECT 470MF	20% 16V
C071	1-164-096-11	CERAMIC 0.01MF	50V
C072	1-164-161-11	CERAMIC CHIP 0.0022MF	10% 50V
C353	1-163-231-11	CERAMIC CHIP 15PF	5% 50V
C354	1-163-133-00	CERAMIC CHIP 470PF	5% 50V
C355	1-124-902-00	ELECT 0.47MF	20% 50V
C356	1-126-963-11	ELECT 4.7MF	20% 50V
C357	1-124-902-00	ELECT 0.47MF	20% 50V
C358	1-164-232-11	CERAMIC CHIP 0.01MF	10% 50V
C359	1-126-933-11	ELECT 100MF	20% 16V
C360	1-124-902-00	ELECT 0.47MF	20% 50V
C361	1-124-902-00	ELECT 0.47MF	20% 50V
C362	1-124-902-00	ELECT 0.47MF	20% 50V
C363	1-164-232-11	CERAMIC CHIP 0.01MF	10% 50V
C364	1-164-232-11	CERAMIC CHIP 0.01MF	10% 50V
C365	1-164-232-11	CERAMIC CHIP 0.01MF	10% 50V
C366	1-137-399-11	FILM 0.1MF	5% 50V
C367	1-137-399-11	FILM 0.1MF	5% 50V
C368	1-137-399-11	FILM 0.1MF	5% 50V
C369	1-163-243-11	CERAMIC CHIP 47PF	5% 50V
C370	1-163-037-11	CERAMIC CHIP 0.022MF	10% 50V
C371	1-163-141-00	CERAMIC CHIP 0.001MF	5% 50V
C372	1-124-902-00	ELECT 0.47MF	20% 50V
C373	1-124-903-11	ELECT 1MF	20% 50V
C376	1-126-964-11	ELECT 10MF	20% 50V
C377	1-137-399-11	FILM 0.1MF	5% 50V
C378	1-136-244-11	FILM 0.1MF	5% 50V
C379	1-164-232-11	CERAMIC CHIP 0.01MF	10% 50V
C380	1-126-935-11	ELECT 470MF	20% 16V
C383	1-137-399-11	FILM 0.1MF	5% 50V
C385	1-164-182-11	CERAMIC CHIP 0.0033MF	10% 50V
C386	1-164-232-11	CERAMIC CHIP 0.01MF	10% 50V
C387	1-124-925-11	ELECT 2.2MF	20% 50V

REF. NO.	PART NO.	DESCRIPTION	REMARK
C388	1-124-902-00	ELECT 0.47MF	20% 50V
C390	1-124-903-11	ELECT 1MF	20% 50V
C391	1-163-017-00	CERAMIC CHIP 0.0047MF	10% 50V
C392	1-163-251-11	CERAMIC CHIP 100PF	5% 50V
C461	1-128-551-11	ELECT 22MF	20% 25V (KV-35V35)
C462	1-124-925-11	ELECT 2.2MF	20% 50V
C463	1-124-925-11	ELECT 2.2MF	20% 50V
C464	1-163-017-00	CERAMIC CHIP 0.0047MF	10% 50V (KV-35V45/35V75)
C466	1-104-666-11	ELECT 220MF	20% 25V
C467	1-163-017-00	CERAMIC CHIP 0.0047MF	10% 50V (KV-35V45/35V75)
C468	1-104-664-11	ELECT 47MF	20% 25V
C470	1-124-925-11	ELECT 2.2MF	20% 50V
C471	1-104-666-11	ELECT 220MF	20% 25V
C472	1-136-173-00	FILM 0.47MF	5% 50V
C473	1-136-169-00	FILM 0.22MF	5% 50V
C474	1-126-942-61	ELECT 1000MF	20% 25V
C475	1-136-169-00	FILM 0.22MF	5% 50V
C476	1-126-942-61	ELECT 1000MF	20% 25V (KV-35V35)
C477	1-126-942-61	ELECT 1000MF	20% 25V (KV-35V35)
C478	1-126-934-11	ELECT 220MF	20% 16V (KV-35V45/35V75)
C501	1-102-110-00	CERAMIC 220PF	10% 50V
C502	1-124-902-00	ELECT 0.47MF	20% 50V
C503	1-163-003-11	CERAMIC CHIP 330PF	10% 50V
C504	1-102-212-00	CERAMIC 820PF	10% 500V
C505	1-102-002-00	CERAMIC 680PF	10% 500V
C506	1-106-383-00	MYLAR 0.047MF	10% 200V
C507	1-162-116-51	CERAMIC 680PF	10% 2KV
C508	1-102-244-00	CERAMIC 220PF	10% 500V
C509	1-162-116-00	CERAMIC 680PF	10% 2KV
C510	1-106-367-00	MYLAR 0.01MF	10% 100V
C511	1-115-460-11	FILM 0.022MF	3% 1.2KV
C513	1-136-334-51	FILM 0.033MF	5% 630V
C514	1-110-634-11	FILM 0.82MF	5% 200V
C515	1-106-343-00	MYLAR 0.001MF	10% 100V
C516	1-115-461-11	FILM 2MF	5% 200V
C517	1-107-649-11	ELECT 2.2MF	20% 250V
C518	1-106-395-00	MYLAR 0.15MF	10% 200V
C519	1-162-815-11	CERAMIC 47PF	5% 500V
C520	1-164-645-11	CERAMIC 1000PF	10% 500V
C521	1-164-161-11	CERAMIC CHIP 0.0022MF	10% 50V
C522	1-124-903-11	ELECT 1MF	20% 50V
C525	1-102-244-00	CERAMIC 220PF	10% 500V
C526	1-107-662-11	ELECT 22MF	20% 250V
C527	1-162-116-00	CERAMIC 680PF	10% 2KV
C528	1-164-161-11	CERAMIC CHIP 0.0022MF	10% 50V
C529	1-128-551-11	ELECT 22MF	20% 25V
C530	1-137-366-11	FILM 0.0022MF	5% 50V
C531	1-126-965-11	ELECT 22MF	20% 50V
C532	1-126-965-11	ELECT 22MF	20% 50V
C537	1-126-942-61	ELECT 1000MF	20% 25V
C539	1-126-942-91	ELECT 1000MF	20% 25V
C540	1-123-024-21	ELECT 33MF	160V
C541	1-128-560-11	ELECT 22MF	20% 100V
C542	1-106-383-00	MYLAR 0.047MF	10% 200V
C543	1-162-131-11	CERAMIC 220PF	10% 2KV
C545	1-106-387-00	MYLAR 0.068MF	10% 200V
C546	1-106-343-00	MYLAR 0.001MF	10% 100V
C547	1-106-343-00	MYLAR 0.001MF	10% 100V
C561	1-126-967-11	ELECT 47MF	20% 50V
C563	1-126-923-11	ELECT 220MF	20% 10V
C564	1-124-903-11	ELECT 1MF	20% 50V
C565	1-126-969-11	ELECT 220MF	20% 50V
C566	1-126-964-11	ELECT 10MF	20% 50V
C568	1-136-169-00	FILM 0.22MF	5% 50V

The components identified by shading and mark Δ are critical for safety. Replace only with part number specified.

Les composants identifiés par une trame et une marque Δ sont critiques pour la sécurité. Ne les remplacer que par une pièce portant le numéro spécifié.

A

REF. NO.	PART NO.	DESCRIPTION	REMARK	REF. NO.	PART NO.	DESCRIPTION	REMARK
C571	1-104-664-11	ELECT	47MF 20% 25V	D368	8-719-991-33	DIODE 1SS133T-77	
C1002	1-126-964-11	ELECT	10MF 20% 50V	D462	8-719-991-33	DIODE 1SS133T-77	
C1101	1-126-768-11	ELECT	2200MF 20% 16V	D501	8-719-109-89	DIODE RD5.6ESB2	
C1103	1-126-965-11	ELECT	22MF 20% 50V	D502	8-719-945-80	DIODE ERC06-15S	
C1104	1-126-967-11	ELECT	47MF 20% 16V	D503	8-719-945-80	DIODE ERC06-15S	
C1105	1-126-967-11	ELECT	47MF 20% 16V	D504	8-719-900-26	DIODE ERD29-08J	
C1106	1-126-964-11	ELECT	10MF 20% 50V	D505	8-719-908-03	DIODE GP08D	
C1107	1-163-037-11	CERAMIC CHIP	0.022MF 10% 50V	D506	8-719-908-03	DIODE GP08D	
C1108	1-124-903-11	ELECT	1MF 20% 50V	D507	8-719-991-33	DIODE 1SS133T-77	
C1109	1-126-964-11	ELECT	10MF 20% 50V	D515	8-719-302-43	DIODE EL1Z	
C1110	1-163-227-11	CERAMIC CHIP	10PF 0.5PF 50V	D516	8-719-991-33	DIODE 1SS133T-77	
C1111	1-163-227-11	CERAMIC CHIP	10PF 0.5PF 50V	D518	8-719-991-33	DIODE 1SS133T-77	
C1112	1-163-227-11	CERAMIC CHIP	10PF 0.5PF 50V	D519	8-719-302-44	DIODE EL1Z-V1	
C1244	1-124-902-00	ELECT	0.47MF 20% 50V	D520	8-719-991-33	DIODE 1SS133T-77	
C1245	1-124-902-00	ELECT	0.47MF 20% 50V	D521	8-719-921-63	DIODE MTZJ-7.5B	
C1351	1-163-251-11	CERAMIC CHIP	100PF 5% 50V	D530	8-719-979-85	DIODE EGP20G	
C1352	1-126-933-11	ELECT	100MF 20% 16V	D531	8-719-979-85	DIODE EGP20G	
C1353	1-163-037-11	CERAMIC CHIP	0.022MF 10% 50V	D534	8-719-302-43	DIODE EL1Z	
C1354	1-216-295-91	CONDUCTOR, CHIP		D535	8-719-028-72	DIODE RGP02-17EL-6433	
C1401	1-124-902-00	ELECT	0.47MF 20% 50V	D561	8-719-908-03	DIODE GP08D	
C1402	1-126-964-11	ELECT	10MF 20% 50V	D562	8-719-991-33	DIODE 1SS133T-77	
C1403	1-124-902-00	ELECT	0.47MF 20% 50V	D1102	8-719-982-24	DIODE MTZJ-33A	
C1404	1-165-319-11	CERAMIC CHIP	0.1MF 50V	D1103	8-719-109-89	DIODE RD5.6ESB2	
C1405	1-165-319-11	CERAMIC CHIP	0.1MF 50V	D1248	8-719-981-99	DIODE MTZJ-T-77-3.3	
C1406	1-165-319-11	CERAMIC CHIP	0.1MF 50V	D1263	8-719-110-17	DIODE RD10ESB2	
C1407	1-165-319-11	CERAMIC CHIP	0.1MF 50V	D1264	8-719-110-17	DIODE RD10ESB2	
C1408	1-164-161-11	CERAMIC CHIP	0.0022MF 10% 50V			<FERRITE BEAD>	
C1409	1-164-161-11	CERAMIC CHIP	0.0022MF 10% 50V	FB501	1-410-396-41	FERRITE BEAD INDUCTOR 0.45UH	
C1410	1-164-161-11	CERAMIC CHIP	0.0022MF 10% 50V	FB502	1-410-397-21	FERRITE BEAD INDUCTOR 1.1UH	
C1411	1-164-161-11	CERAMIC CHIP	0.0022MF 10% 50V	FB503	1-410-397-21	FERRITE BEAD INDUCTOR 1.1UH	
C1412	1-124-925-11	ELECT	2.2MF 20% 50V			<IC>	
C1413	1-124-925-11	ELECT	2.2MF 20% 50V	IC001	8-752-868-44	IC CXP85640-004S	
C1414	1-164-489-11	CERAMIC CHIP	0.22MF 10% 16V	IC002	8-759-354-28	IC ST24C02FM6TR	
C1415	1-126-965-11	ELECT	22MF 20% 50V	IC002	8-759-354-28	IC ST24C02FM6TR	
C1416	1-126-933-11	ELECT	100MF 20% 16V	IC351	8-752-076-08	IC CXA2025S	
C1417	1-126-965-11	ELECT	22MF 20% 50V	IC461	8-759-980-43	IC TDA2009A	
C1420	1-164-005-11	CERAMIC CHIP	0.47MF 25V	IC501	8-759-700-07	IC NJM2903M	
		<CONNECTOR>		IC561	8-759-192-71	IC STV9379	
CN270	1-573-298-11	CONNECTOR, BOARD TO BOARD	20P	IC1001	8-752-058-68	IC CXA1315M	
CN271	1-573-978-21	CONNECTOR, BOARD TO BOARD	11P	IC1401	8-759-369-39	IC BH3856FS-E2	
CN351	* 1-564-509-11	PLUG, CONNECTOR	6P	IC1402	8-759-100-96	IC uPC4558G2	
CN461	* 1-564-507-11	PLUG, CONNECTOR	4P (KV-35V35)	IC1402	8-759-701-01	IC NJM2904M	
CN461	* 1-564-510-11	PLUG, CONNECTOR	7P (KV-35V45/35V75)			<CHIP CONDUCTOR>	
CN501	* 1-580-798-11	CONNECTOR PIN (DY)	6P	JR001	1-216-295-91	CONDUCTOR, CHIP	
CN502	1-508-784-00	PIN, CONNECTOR (5mm PITCH)	1P	JR1351	1-216-295-91	CONDUCTOR, CHIP	
CN503	* 1-564-507-11	PLUG, CONNECTOR	4P	JR1352	1-216-295-91	CONDUCTOR, CHIP	
CN1001	* 1-564-512-11	PLUG, CONNECTOR	9P	JR4101	1-216-295-91	CONDUCTOR, CHIP	
CN1101	1-573-298-11	CONNECTOR, BOARD TO BOARD	20P	JR4108	1-216-295-91	CONDUCTOR, CHIP	
CN1103	1-573-979-21	CONNECTOR, BOARD TO BOARD	11P	JR4110	1-216-295-91	CONDUCTOR, CHIP	
CN1231	1-564-511-11	PLUG, CONNECTOR	8P	JR4114	1-216-295-91	CONDUCTOR, CHIP	
CN1641	* 1-564-515-11	PLUG, CONNECTOR	12P	JR4116	1-216-295-91	CONDUCTOR, CHIP	
CN1941	1-564-511-11	PLUG, CONNECTOR	8P	JR4120	1-216-295-91	CONDUCTOR, CHIP	
CN3001	1-573-298-11	CONNECTOR, BOARD TO BOARD	20P			<COIL>	
		<DIODE>		L001	1-408-421-00	INDUCTOR 100UH	
D001	8-719-991-33	DIODE 1SS133T-77		L002	1-408-421-00	INDUCTOR 100UH	
D002	8-719-109-89	DIODE RD5.6ESB3		L003	1-410-470-11	INDUCTOR 10UH	
D003	8-719-991-33	DIODE 1SS133T-77		L004	1-410-470-11	INDUCTOR 10UH	
D004	8-719-110-17	DIODE RD10ESB2		L352	1-412-537-31	INDUCTOR 100UH	
D011	8-719-983-20	DIODE MTZJ-T-77-4.3C		L461	1-410-470-11	INDUCTOR 10UH (KV-35V45/35V75)	
D013	8-719-991-33	DIODE 1SS133T-77		L461	1-410-472-41	INDUCTOR 15UH (KV-35V45/35V75)	
D014	8-719-991-33	DIODE 1SS133T-77		L501	1-409-861-11	COIL HORIZONTAL LINEARITY	
D015	8-719-991-33	DIODE 1SS133T-77		L502	1-412-552-11	INDUCTOR 2.2mH	
D353	8-719-991-33	DIODE 1SS133T-77					
D356	8-719-991-33	DIODE 1SS133T-77					
D360	8-719-110-17	DIODE RD10ESB2					
D362	8-719-991-33	DIODE 1SS133T-77					



Les composants identifiés par une trame et une marque Δ sont critiques pour la sécurité. Ne les remplacer que par une pièce portant le numéro spécifique.

The components identified by shading and mark Δ are critical for safety. Replace only with part number specified.

REF. NO.	PART NO.	DESCRIPTION	REMARK	REF. NO.	PART NO.	DESCRIPTION	REMARK
L503	1-406-677-11	COIL, CHOKE 10mH		R023	1-216-089-91	METAL GLAZE 47K	5% 1/10W
L511	1-406-607-11	COIL, CHOKE 15mH		R024	1-216-085-00	METAL GLAZE 33K	5% 1/10W
L517	1-412-552-11	INDUCTOR 2.2mH		R025	1-216-121-91	METAL GLAZE 1M	5% 1/10W
L541	1-406-677-11	COIL, CHOKE 10mH		R026	1-216-019-00	METAL GLAZE 56	5% 1/10W
L1101	1-408-421-00	INDUCTOR 100UH		R027	1-216-049-91	METAL GLAZE 1K	5% 1/10W
L1102	1-410-470-11	INDUCTOR 10UH		R028	1-249-417-11	CARBON 1K	5% 1/4W
L1401	1-408-421-00	INDUCTOR 100UH		R029	1-216-025-91	METAL GLAZE 100	5% 1/10W
		<IC LINK>		R030	1-249-425-11	CARBON 4.7K	5% 1/4W
PS461	Δ 1-532-984-91	LINK IC (2A/90V)		R031	1-247-815-91	CARBON 220	5% 1/4W
		<TRANSISTOR>		R032	1-247-815-91	CARBON 220	5% 1/4W
Q001	8-729-216-22	TRANSISTOR 2SA1162-G		R033	1-247-815-91	CARBON 220	5% 1/4W
Q002	8-729-422-27	TRANSISTOR 2SD601A-Q		R034	1-247-815-91	CARBON 220	5% 1/4W
Q003	8-729-422-27	TRANSISTOR 2SD601A-Q		R035	1-247-815-91	CARBON 220	5% 1/4W
Q004	8-729-216-22	TRANSISTOR 2SA1162-G		R036	1-216-049-91	METAL GLAZE 1K	5% 1/10W
Q010	8-729-422-27	TRANSISTOR 2SD601A-Q		R037	1-216-049-91	METAL GLAZE 1K	5% 1/10W
Q011	8-729-422-27	TRANSISTOR 2SD601A-Q		R038	1-216-049-91	METAL GLAZE 1K	5% 1/10W
Q012	8-729-422-27	TRANSISTOR 2SD601A-Q		R039	1-247-807-31	CARBON 100	5% 1/4W
Q013	8-729-422-27	TRANSISTOR 2SD601A-Q		R040	1-247-815-91	CARBON 220	5% 1/4W
Q014	8-729-422-27	TRANSISTOR 2SD601A-Q		R041	1-216-065-00	METAL GLAZE 4.7K	5% 1/10W
Q015	8-729-422-27	TRANSISTOR 2SD601A-Q		R042	1-216-065-00	METAL GLAZE 4.7K	5% 1/10W
Q016	8-729-422-27	TRANSISTOR 2SD601A-Q		R043	1-216-049-91	METAL GLAZE 1K	5% 1/10W
Q017	8-729-216-22	TRANSISTOR 2SA1162-G		R044	1-216-049-91	METAL GLAZE 1K	5% 1/10W
Q301	8-729-216-22	TRANSISTOR 2SA1162-G		R045	1-247-815-91	CARBON 220	5% 1/4W
Q302	8-729-216-22	TRANSISTOR 2SA1162-G		R046	1-247-815-91	CARBON 220	5% 1/4W
Q303	8-729-216-22	TRANSISTOR 2SA1162-G		R047	1-249-417-11	CARBON 1K	5% 1/4W
Q354	8-729-422-27	TRANSISTOR 2SD601A-Q		R048	1-249-417-11	CARBON 1K	5% 1/4W
Q356	8-729-216-22	TRANSISTOR 2SA1162-G		R049	1-249-417-11	CARBON 1K	5% 1/4W
Q357	8-729-422-27	TRANSISTOR 2SD601A-Q		R050	1-247-815-91	CARBON 220	5% 1/4W
Q358	8-729-422-27	TRANSISTOR 2SD601A-Q		R051	1-247-815-91	CARBON 220	5% 1/4W
Q461	8-729-422-27	TRANSISTOR 2SD601A-Q		R052	1-216-061-00	METAL GLAZE 3.3K	5% 1/10W
Q462	8-729-216-22	TRANSISTOR 2SA1162-G		R053	1-216-061-00	METAL GLAZE 3.3K	5% 1/10W
Q501	8-729-140-96	TRANSISTOR 2SD774-34		R054	1-216-061-00	METAL GLAZE 3.3K	5% 1/10W
Q502	Δ 8-729-035-75	TRANSISTOR 2SC5148		R055	1-216-097-91	METAL GLAZE 100K	5% 1/10W
Q503	8-729-422-27	TRANSISTOR 2SD601A-Q		R056	1-216-033-00	METAL GLAZE 220	5% 1/10W
Q511	Δ 8-729-422-26	TRANSISTOR 2SD601A-QRS-TX		R057	1-249-417-11	CARBON 1K	5% 1/4W
Q512	Δ 8-729-809-29	TRANSISTOR 2SC4159-E		R058	1-216-033-00	METAL GLAZE 220	5% 1/10W
Q561	8-729-422-27	TRANSISTOR 2SD601A-Q		R064	1-247-815-91	CARBON 220	5% 1/4W
Q562	8-729-422-27	TRANSISTOR 2SD601A-Q		R065	1-247-815-91	CARBON 220	5% 1/4W
Q563	8-729-105-08	TRANSISTOR 2SA1330-O6		R066	1-247-815-91	CARBON 220	5% 1/4W
Q1102	8-729-119-78	TRANSISTOR 2SC2785-HFE		R067	1-249-413-11	CARBON 470	5% 1/4W
Q1103	8-729-422-27	TRANSISTOR 2SD601A-Q		R068	1-247-815-91	CARBON 220	5% 1/4W
Q1231	8-729-422-27	TRANSISTOR 2SD601A-Q		R069	1-247-815-91	CARBON 220	5% 1/4W
Q1232	8-729-422-27	TRANSISTOR 2SD601A-Q		R070	1-247-815-91	CARBON 220	5% 1/4W
		<RESISTOR>		R071	1-247-815-91	CARBON 220	5% 1/4W
R001	1-216-045-00	METAL GLAZE 680	5% 1/10W	R072	1-216-033-00	METAL GLAZE 220	5% 1/10W
R002	1-247-815-91	CARBON 220	5% 1/4W	R073	1-216-033-00	METAL GLAZE 220	5% 1/10W
R003	1-216-097-91	METAL GLAZE 100K	5% 1/10W	R074	1-216-033-00	METAL GLAZE 220	5% 1/10W
R004	1-216-121-91	METAL GLAZE 1M	5% 1/10W	R075	1-216-033-00	METAL GLAZE 220	5% 1/10W
R005	1-247-815-91	CARBON 220	5% 1/4W	R076	1-216-033-00	METAL GLAZE 220	5% 1/10W
R006	1-247-815-91	CARBON 220	5% 1/4W	R077	1-216-033-00	METAL GLAZE 220	5% 1/10W
R007	1-216-073-00	METAL GLAZE 10K	5% 1/10W	R078	1-249-417-11	CARBON 1K	5% 1/4W
R008	1-247-815-91	CARBON 220	5% 1/4W	R079	1-216-033-00	METAL GLAZE 220	5% 1/10W
R009	1-216-073-00	METAL GLAZE 10K	5% 1/10W	R080	1-216-065-00	METAL GLAZE 4.7K	5% 1/10W
R010	1-216-037-00	METAL GLAZE 330	5% 1/10W	R081	1-216-025-91	METAL GLAZE 100	5% 1/10W
R011	1-216-065-00	METAL GLAZE 4.7K	5% 1/10W	R082	1-216-025-91	METAL GLAZE 100	5% 1/10W
R012	1-216-033-00	METAL GLAZE 220	5% 1/10W	R083	1-249-429-11	CARBON 10K	5% 1/4W
R013	1-216-065-00	METAL GLAZE 4.7K	5% 1/10W	R084	1-216-049-91	METAL GLAZE 1K	5% 1/10W
R014	1-216-065-00	METAL GLAZE 4.7K	5% 1/10W	R087	1-247-815-91	CARBON 220	5% 1/4W
R015	1-216-073-00	METAL GLAZE 10K	5% 1/10W	R090	1-216-033-00	METAL GLAZE 220	5% 1/10W
R016	1-216-073-00	METAL GLAZE 10K	5% 1/10W	R092	1-249-429-11	CARBON 10K	5% 1/4W
R019	1-249-425-11	CARBON 4.7K	5% 1/4W	R097	1-216-065-00	METAL GLAZE 4.7K	5% 1/10W
R020	1-216-065-00	METAL GLAZE 4.7K	5% 1/10W	R099	1-216-065-00	METAL GLAZE 4.7K	5% 1/10W
R022	1-249-429-11	CARBON 10K	5% 1/4W	R131	1-216-035-00	METAL GLAZE 270	5% 1/10W
				R132	1-216-115-00	METAL GLAZE 560K	5% 1/10W
				R133	1-216-039-00	METAL GLAZE 390	5% 1/10W
				R135	1-216-073-00	METAL GLAZE 10K	5% 1/10W
				R136	1-216-073-00	METAL GLAZE 10K	5% 1/10W
				R137	1-216-047-91	METAL GLAZE 820	5% 1/10W
				R353	1-208-786-11	METAL GLAZE 1.5K	0.50% 1/10W
				R354	1-216-077-00	METAL GLAZE 15K	5% 1/10W

The components identified by shading and mark Δ are critical for safety. Replace only with part number specified.

Les composants identifiés par une trame et une marque Δ sont critiques pour la sécurité. Ne les remplacer que par une pièce portant le numéro spécifié.

The components identified by \square in this manual have been carefully factory-selected for each set in order to satisfy regulations regarding X-ray radiation. Should replacement be required, replace only with the value originally used.

A

REF. NO.	PART NO.	DESCRIPTION	REMARK	REF. NO.	PART NO.	DESCRIPTION	REMARK
R355	1-216-033-00	METAL GLAZE 220	5% 1/10W	R481	1-249-385-11	CARBON 2.2	5% 1/4W F
R356	1-216-033-00	METAL GLAZE 220	5% 1/10W	R482	1-249-421-11	CARBON 2.2K	5% 1/4W (KV-35V35)
R358	1-247-815-91	CARBON 220	5% 1/4W	R501	1-216-037-00	METAL GLAZE 330	5% 1/10W
R359	1-247-815-91	CARBON 220	5% 1/4W	R502	1-216-061-00	METAL GLAZE 3.3K	5% 1/10W
R360	1-247-815-91	CARBON 220	5% 1/4W	R503	1-249-426-11	CARBON 5.6K	5% 1/4W F
R361	1-216-025-91	METAL GLAZE 100	5% 1/10W	R504	Δ 1-215-917-51	METAL OXIDE 1K	5% 3W F
R362	1-216-025-91	METAL GLAZE 100	5% 1/10W	R505	1-249-431-11	CARBON 15K	5% 1/4W
R363	1-216-025-91	METAL GLAZE 100	5% 1/10W	R506	1-215-861-00	METAL OXIDE 47	5% 1W F
R364	1-216-101-00	METAL GLAZE 150K	5% 1/10W	R507	1-249-401-11	CARBON 47	5% 1/4W
R365	1-216-101-00	METAL GLAZE 150K	5% 1/10W	R508	1-249-427-11	CARBON 6.8K	5% 1/4W
R366	1-216-089-91	METAL GLAZE 47K	5% 1/10W	R509	1-247-750-11	CARBON 680	5% 1/2W F
R367	1-216-097-91	METAL GLAZE 100K	5% 1/10W	R510	Δ 1-215-860-51	METAL OXIDE 33	5% 1W F
R368	1-249-441-11	CARBON 100K	5% 1/4W	R511	Δ 1-215-886-51	METAL OXIDE 100	5% 2W F
R369	1-216-097-91	METAL GLAZE 100K	5% 1/10W	R512	Δ 1-215-886-51	METAL OXIDE 100	5% 2W F
R370	1-249-417-11	CARBON 1K	5% 1/4W	R515	1-216-083-00	METAL GLAZE 27K	5% 1/10W
R371	1-216-053-00	METAL GLAZE 1.5K	5% 1/10W	R516	1-216-057-00	METAL GLAZE 2.2K	5% 1/10W
R372	1-216-113-00	METAL GLAZE 470K	5% 1/10W	R517	1-249-415-11	CARBON 680	5% 1/4W
R373	1-216-073-00	METAL GLAZE 10K	5% 1/10W	R518	1-216-073-00	METAL GLAZE 10K	5% 1/10W
R374	1-216-125-00	METAL GLAZE 1.5M	5% 1/10W	R519	1-249-411-11	CARBON 330	5% 1/4W
R375	1-216-025-91	METAL GLAZE 100	5% 1/10W	R521	1-216-073-00	METAL GLAZE 10K	5% 1/10W
R376	1-216-073-00	METAL GLAZE 10K	5% 1/10W	R523	1-216-071-00	METAL GLAZE 8.2K	5% 1/10W
R379	1-216-033-00	METAL GLAZE 220	5% 1/10W	R523	1-216-073-00	METAL GLAZE 10K	5% 1/10W (KV-35V35)
R380	1-247-815-91	CARBON 220	5% 1/4W	R524	1-249-429-11	CARBON 10K	5% 1/4W (KV-35V45/35V75)
R381	1-247-815-91	CARBON 220	5% 1/4W	R525	1-216-071-00	METAL GLAZE 8.2K	5% 1/10W
R382	1-216-033-00	METAL GLAZE 220	5% 1/10W	R528	1-216-081-00	METAL GLAZE 22K	5% 1/10W
R383	1-216-049-91	METAL GLAZE 1K	5% 1/10W	R529	1-208-812-11	METAL GLAZE 18K	0.50% 1/10W
R384	1-216-109-00	METAL GLAZE 330K	5% 1/10W	R530	Δ	METAL GLAZE	1/10W
R385	1-249-422-11	CARBON 2.7K	5% 1/4W	R531	Δ	METAL GLAZE	1/10W
R386	1-216-049-91	METAL GLAZE 1K	5% 1/10W	R532	1-208-760-11	METAL GLAZE 120	0.50% 1/10W
R387	1-216-049-91	METAL GLAZE 1K	5% 1/10W	R533	Δ 1-215-878-51	METAL OXIDE 33K	5% 1W F
R388	1-216-089-91	METAL GLAZE 47K	5% 1/10W	R535	1-216-101-00	METAL GLAZE 150K	5% 1/10W
R389	1-216-067-00	METAL GLAZE 5.6K	5% 1/10W	R536	Δ 1-216-397-51	METAL OXIDE 4.7	5% 3W F
R390	1-216-035-00	METAL GLAZE 270	5% 1/10W	R537	Δ 1-216-470-51	METAL OXIDE 18	5% 3W F
R391	1-208-810-11	METAL GLAZE 15K	0.50% 1/10W	R538	1-247-887-00	CARBON 220K	5% 1/4W
R392	1-216-025-91	METAL GLAZE 100	5% 1/10W	R541	Δ 1-249-377-91	CARBON 0.47	5% 1/4W F
R393	1-216-043-91	METAL GLAZE 560	5% 1/10W	R542	Δ 1-249-397-91	CARBON 22	5% 1/4W F
R394	1-216-059-00	METAL GLAZE 2.7K	5% 1/10W	R543	1-249-377-11	CARBON 0.47	5% 1/4W F
R395	1-216-061-00	METAL GLAZE 3.3K	5% 1/10W	R546	1-215-452-00	METAL 20K	1% 1/4W
R396	1-249-417-11	CARBON 1K	5% 1/4W	R547	1-215-457-00	METAL 33K	1% 1/4W
R397	1-249-425-11	CARBON 4.7K	5% 1/4W	R548	Δ 1-215-872-51	METAL OXIDE 3.3K	5% 1W F
R461	1-216-065-00	METAL GLAZE 4.7K	5% 1/10W	R549	1-215-437-00	METAL 4.7K	1% 1/4W
R462	1-216-089-91	METAL GLAZE 47K	5% 1/10W	R550	Δ 1-249-377-91	CARBON 0.47	5% 1/4W F
R463	1-249-435-11	CARBON 33K	5% 1/4W	R551	Δ 1-215-873-51	METAL OXIDE 4.7K	5% 1W F
R464	1-216-097-91	METAL GLAZE 100K	5% 1/10W	R553	Δ 1-249-377-91	CARBON 0.47	5% 1/4W F
R465	1-249-413-11	CARBON 470	5% 1/4W	R561	1-216-073-00	METAL GLAZE 10K	5% 1/10W
R466	1-249-384-11	CARBON 1.8	5% 1/4W F (KV-35V45/35V75)	R563	Δ 1-216-351-51	METAL OXIDE 1.5	5% 1W F
R466	1-249-387-11	CARBON 3.3	5% 1/4W F (KV-35V35)	R564	1-249-393-11	CARBON 10	5% 1/4W
R467	1-216-069-00	METAL GLAZE 6.8K	5% 1/10W	R565	Δ 1-215-890-51	METAL OXIDE 470	5% 2W F
R469	1-216-057-00	METAL GLAZE 2.2K	5% 1/10W (KV-35V35)	R566	1-216-073-00	METAL GLAZE 10K	5% 1/10W
R469	1-216-067-00	METAL GLAZE 5.6K	5% 1/10W (KV-35V45/35V75)	R567	Δ 1-249-385-91	CARBON 2.2	5% 1/4W F
R470	1-216-077-00	METAL GLAZE 15K	5% 1/10W (KV-35V45/35V75)	R568	1-216-073-00	METAL GLAZE 10K	5% 1/10W
R471	1-216-069-00	METAL GLAZE 6.8K	5% 1/10W	R569	1-216-073-00	METAL GLAZE 10K	5% 1/10W
R472	1-216-057-00	METAL GLAZE 2.2K	5% 1/10W (KV-35V35)	R570	1-216-089-91	METAL GLAZE 47K	5% 1/10W
R472	1-216-067-00	METAL GLAZE 5.6K	5% 1/10W (KV-35V45/35V75)	R571	1-216-073-00	METAL GLAZE 10K	5% 1/10W
R473	1-249-398-11	CARBON 27	5% 1/4W	R572	1-216-081-00	METAL GLAZE 22K	5% 1/10W
R474	1-216-077-00	METAL GLAZE 15K	5% 1/10W (KV-35V45/35V75)	R573	1-216-097-91	METAL GLAZE 100K	5% 1/10W
R475	1-249-430-11	CARBON 12K	5% 1/4W	R574	Δ 1-216-365-51	METAL OXIDE 0.47	5% 2W F
R476	1-249-430-11	CARBON 12K	5% 1/4W	R575	1-216-113-00	METAL GLAZE 470K	5% 1/10W
R477	1-249-398-11	CARBON 27	5% 1/4W	R576	1-216-073-00	METAL GLAZE 10K	5% 1/10W
R478	1-249-418-11	CARBON 1.2K	5% 1/4W F	R577	1-216-097-91	METAL GLAZE 100K	5% 1/10W
R479	1-249-418-11	CARBON 1.2K	5% 1/4W F	R578	1-208-784-11	METAL GLAZE 1.2K	0.50% 1/10W
R480	1-249-385-11	CARBON 2.2	5% 1/4W F	R579	1-208-842-11	METAL GLAZE 330K	0.50% 1/10W
				R580	1-249-441-11	CARBON 100K	5% 1/4W
				R1001	1-247-807-31	CARBON 100	5% 1/4W
				R1002	1-247-807-31	CARBON 100	5% 1/4W
				R1005	1-216-073-00	METAL GLAZE 10K	5% 1/10W
				R1101	1-216-049-91	METAL GLAZE 1K	5% 1/10W



Les composants identifiés par une trame et une marque Δ sont critiques pour la securite. Ne les remplacer que par une piece portant le numero specifie.

The componants identified by shading and mark Δ are critical for safety. Replace only with part number specified.

REF. NO.	PART NO.	DESCRIPTION	REMARK
R1102	A 1-215-900-51	METAL OXIDE 22K	5% 2W F
R1103	1-216-051-00	METAL GLAZE 1.2K	5% 1/10W
R1104	1-216-083-00	METAL GLAZE 27K	5% 1/10W
R1105	1-216-689-11	METAL GLAZE 39K	5% 1/10W
R1106	1-216-049-91	METAL GLAZE 1K	5% 1/10W
R1107	1-216-065-00	METAL GLAZE 4.7K	5% 1/10W
R1108	1-216-073-00	METAL GLAZE 10K	5% 1/10W
R1109	1-216-019-00	METAL GLAZE 56	5% 1/10W
R1110	1-216-019-00	METAL GLAZE 56	5% 1/10W
R1111	1-216-019-00	METAL GLAZE 56	5% 1/10W
R1115	1-216-045-00	METAL GLAZE 680	5% 1/10W
R1117	1-249-425-11	CARBON 4.7K	5% 1/4W
R1118	1-249-425-11	CARBON 4.7K	5% 1/4W
R1120	1-216-057-00	METAL GLAZE 2.2K	5% 1/10W
R1121	1-216-035-00	METAL GLAZE 270	5% 1/10W
R1122	1-216-115-00	METAL GLAZE 560K	5% 1/10W
R1123	1-216-039-00	METAL GLAZE 390	5% 1/10W
R1125	1-216-057-00	METAL GLAZE 2.2K	5% 1/10W
R1126	1-216-035-00	METAL GLAZE 270	5% 1/10W
R1127	1-216-115-00	METAL GLAZE 560K	5% 1/10W
R1128	1-216-039-00	METAL GLAZE 390	5% 1/10W
R1130	1-216-057-00	METAL GLAZE 2.2K	5% 1/10W
R1255	1-216-295-91	CONDUCTOR, CHIP	
R1258	1-216-061-00	METAL GLAZE 3.3K	5% 1/10W
R1259	1-216-097-91	METAL GLAZE 100K	5% 1/10W
R1260	1-216-061-00	METAL GLAZE 3.3K	5% 1/10W
R1294	1-216-049-91	METAL GLAZE 1K	5% 1/10W
R1295	1-216-049-91	METAL GLAZE 1K	5% 1/10W
R1351	1-247-815-91	CARBON 220	5% 1/4W
R1352	1-247-815-91	CARBON 220	5% 1/4W
R1353	1-247-815-91	CARBON 220	5% 1/4W
R1354	1-216-033-00	METAL GLAZE 220	5% 1/10W
R1355	1-216-025-91	METAL GLAZE 100	5% 1/10W
R1356	1-216-025-91	METAL GLAZE 100	5% 1/10W
R1357	1-216-025-91	METAL GLAZE 100	5% 1/10W
R1358	1-247-807-31	CARBON 100	5% 1/4W
R1359	1-216-025-91	METAL GLAZE 100	5% 1/10W
R1360	1-216-065-00	METAL GLAZE 4.7K	5% 1/10W
R1361	1-216-063-91	METAL GLAZE 3.9K	5% 1/10W
R1362	1-216-295-91	CONDUCTOR, CHIP	
R1407	1-216-073-00	METAL GLAZE 10K	5% 1/10W
R1408	1-249-429-11	CARBON 10K	5% 1/4W
R1409	1-249-429-11	CARBON 10K	5% 1/4W
R1411	1-216-073-00	METAL GLAZE 10K	5% 1/10W
R1412	1-216-093-00	METAL GLAZE 68K	5% 1/10W
R1413	1-216-089-91	METAL GLAZE 47K	5% 1/10W
R1414	1-216-089-91	METAL GLAZE 47K	5% 1/10W
R1415	1-216-025-91	METAL GLAZE 100	5% 1/10W
R1418	1-216-093-00	METAL GLAZE 68K	5% 1/10W
R1419	1-216-089-91	METAL GLAZE 47K	5% 1/10W
R1420	1-216-089-91	METAL GLAZE 47K	5% 1/10W
R1421	1-216-025-91	METAL GLAZE 100	5% 1/10W
R1424	1-247-807-31	CARBON 100	5% 1/4W
R1425	1-247-807-31	CARBON 100	5% 1/4W
<SWITCH>			
S501	1-572-707-11	SWITCH, LEVER	
<TRANSFORMER>			
T501	1-437-195-11	TRANSFORMER, HORIZONTAL DRIVE	
T502	A 1-429-408-11	TRANSFORMER, FERRITE (PMT)	
T503	A X-4033-489-1	TRANSFORMER ASSY, FLYBACK	
(NX-3001/JIC)			
T504	1-413-059-00	TRANSFORMER, FERRITE (DFT)	

REF. NO.	PART NO.	DESCRIPTION	REMARK
<TUNER>			
TU102	A 8-598-340-00	TUNER BTP-WA404	
<CRYSTAL>			
X001	1-578-774-11	VIBRATOR, CRYSTAL	
X353	1-567-505-11	OSCILLATOR, CRYSTAL	
X354	1-577-611-11	OSCILALTOR, CERAMIC	

* A-1316-262-A G BOARD, COMPLETE			

4-382-854-11	SCREW (M3X10), P, SW (+)		
<CAPACITOR>			
C601	1-130-711-00	FILM	0.22MF 20% 250V
C603	A 1-113-915-51	ELECT	0.001MF 20% 250V
C604	A 1-136-346-51	FILM	0.22MF 20% 125V
C605	A 1-136-346-51	FILM	0.22MF 20% 125V
C606	A 1-115-388-11	ELECT	560MF 20% 200V
C607	A 1-115-388-11	ELECT	560MF 20% 200V
C608	1-164-645-11	CERAMIC	1000PF 10% 500V
C609	1-136-173-00	FILM	0.47MF 5% 50V
C610	1-136-173-00	FILM	0.47MF 5% 50V
C611	1-136-169-00	FILM	0.22MF 5% 50V
C612	1-136-169-00	FILM	0.22MF 5% 50V
C613	1-164-645-11	CERAMIC	1000PF 10% 500V
C614	1-164-645-11	CERAMIC	1000PF 10% 500V
C615	1-136-759-11	FILM	0.039MF 5% 630V
C617	A 1-113-915-51	ELECT	0.001MF 20% 250V
C641	1-126-943-11	ELECT	2200MF 20% 25V
C642	1-126-952-11	ELECT	1000MF 20% 16V
C643	1-107-641-11	ELECT	220MF 20% 160V
C646	1-126-933-11	ELECT	100MF 20% 16V
C647	1-128-551-11	ELECT	22MF 20% 25V
C648	1-126-933-11	ELECT	100MF 20% 16V
C651	1-137-366-11	FILM	0.0022MF 5% 50V
C652	1-106-351-00	MYLAR	0.0022MF 200V
C653	1-107-636-11	ELECT	10MF 20% 160V
C654	1-164-625-11	CERAMIC	680PF 10% 500V
C655	1-164-625-11	CERAMIC	680PF 10% 500V
C656	1-164-625-11	CERAMIC	680PF 10% 500V
C657	1-164-625-11	CERAMIC	680PF 10% 500V
C690	1-164-645-11	CERAMIC	1000PF 10% 500V
C691	1-164-645-11	CERAMIC	1000PF 10% 500V
<CONNECTOR>			
CN601	* 1-573-963-11	PIN, CONNECTOR (PC BOARD) 3P	
CN602	* 1-580-844-11	PIN, CONNECTOR (POWER)	
CN603	* 1-573-963-11	PIN, CONNECTOR (PC BOARD) 3P	
CN641	* 1-564-515-11	PLUG, CONNECTOR 12P	
<DIODE>			
D601	8-719-911-19	DIODE 1SS119-25	
D602	A 8-719-510-63	DIODE D4SB60L F	
D603	8-719-911-19	DIODE 1SS119-25	
D604	8-719-911-19	DIODE 1SS119-25	
D605	8-719-911-19	DIODE 1SS119-25	
D606	8-719-911-19	DIODE 1SS119-25	
D607	8-719-911-19	DIODE 1SS119-25	
D608	8-719-911-19	DIODE 1SS119-25	
D609	8-719-911-19	DIODE 1SS119-25	
D610	8-719-911-19	DIODE 1SS119-25	
D615	8-719-028-45	DIODE D2L20U	



The components identified by shading and mark Δ are critical for safety. Replace only with part number specified.

Les composants identifiés par une trame et une marque Δ sont critiques pour la sécurité. Ne les remplacer que par une pièce portant le numéro spécifié.

REF. NO.	PART NO.	DESCRIPTION	REMARK
D641	8-719-052-40	DIODE RBA-1004B	
D643	8-719-028-45	DIODE D2L20U	
D644	8-719-028-45	DIODE D2L20U	
D645	8-719-028-45	DIODE D2L20U	
D646	8-719-510-12	DIODE D10SC4M	
D648	8-719-057-52	DIODE EZ0150AV1	
D649	8-719-510-02	DIODE D1NS4	
D650	8-719-510-02	DIODE D1NS4	
<FUSE>			
F601	Δ 1-576-193-11	FUSE 6.3A/125V	
	1-533-223-11	HOLDER, FUSE ; F601	
<FERRITE BEAD>			
FB601	1-410-397-21	FERRITE BEAD INDUCTOR 1.1UH	
FB602	1-410-397-21	FERRITE BEAD INDUCTOR 1.1UH	
FB641	1-410-397-21	FERRITE BEAD INDUCTOR 1.1UH	
FB642	1-410-397-21	FERRITE BEAD INDUCTOR 1.1UH	
FB643	1-410-397-21	FERRITE BEAD INDUCTOR 1.1UH	
FB644	1-410-397-21	FERRITE BEAD INDUCTOR 1.1UH	
FB645	1-410-397-21	FERRITE BEAD INDUCTOR 1.1UH	
FB646	1-410-397-21	FERRITE BEAD INDUCTOR 1.1UH	
FB647	1-410-397-21	FERRITE BEAD INDUCTOR 1.1UH	
FB648	1-410-397-21	FERRITE BEAD INDUCTOR 1.1UH	
<IC>			
IC641	8-749-920-58	IC SI-3090CA	
IC642	8-759-701-56	IC NJM78M05FA	
IC643	8-749-012-13	IC DM-58	
<COIL>			
L642	1-412-529-11	INDUCTOR 22UH	
L643	1-412-525-31	INDUCTOR 10UH	
<TRANSISTOR>			
Q601	Δ 8-729-019-51	TRANSISTOR 2SC4834MNP	
Q602	Δ 8-729-019-51	TRANSISTOR 2SC4834MNP	
Q644	8-729-119-78	TRANSISTOR 2SC2785-HFE	
<RESISTOR>			
R603	Δ 1-219-776-91	CARBON 2.2M	10% 1/2W
R605	1-247-893-11	CARBON 390K	5% 1/4W
R606	1-247-893-11	CARBON 390K	5% 1/4W
R607	Δ 1-202-933-61	FUSIBLE 0.1	10% 1/2W F
R608	Δ 1-216-369-51	METAL OXIDE 1	5% 2W F
R609	1-247-791-91	CARBON 22	5% 1/4W
R610	1-247-791-91	CARBON 22	5% 1/4W
R611	Δ 1-216-369-51	METAL OXIDE 1	5% 2W F
R612	1-247-887-00	CARBON 220K	5% 1/4W
R613	1-247-887-00	CARBON 220K	5% 1/4W
R614	1-247-887-00	CARBON 220K	5% 1/4W
R615	1-247-887-00	CARBON 220K	5% 1/4W
R616	1-247-791-91	CARBON 22	5% 1/4W
R617	1-247-791-91	CARBON 22	5% 1/4W
R622	1-212-958-00	FUSIBLE 10	5% 1/2W F
R623	Δ 1-208-284-11	WIREWOUND 1	5% 20W
R641	1-249-423-11	CARBON 3.3K	5% 1/4W
R642	1-249-423-11	CARBON 3.3K	5% 1/4W
R643	1-249-387-11	CARBON 3.3	5% 1/4W F
R644	Δ 1-215-882-51	METAL OXIDE 22	5% 2W F
R645	Δ 1-260-304-71	CARBON 10	5% 1/2W
R647	1-249-417-11	CARBON 1K	5% 1/4W
R648	1-247-887-00	CARBON 220K	5% 1/4W
R649	1-249-425-11	CARBON 4.7K	5% 1/4W F
R652	1-249-421-11	CARBON 2.2K	5% 1/4W

REF. NO.	PART NO.	DESCRIPTION	REMARK
R661	1-249-413-11	CARBON 470	5% 1/4W F
R662	1-249-429-11	CARBON 10K	5% 1/4W
R663	Δ 1-249-377-91	CARBON 0.47	5% 1/4W F
R664	Δ 1-249-377-91	CARBON 0.47	5% 1/4W F
R665	Δ 1-249-377-91	CARBON 0.47	5% 1/4W F
R666	Δ 1-249-377-91	CARBON 0.47	5% 1/4W F
R667	Δ 1-249-377-91	CARBON 0.47	5% 1/4W F
R668	Δ 1-249-377-91	CARBON 0.47	5% 1/4W F
R670	Δ 1-249-377-91	CARBON 0.47	5% 1/4W F
R671	Δ 1-249-377-91	CARBON 0.47	5% 1/4W F
R672	Δ 1-249-377-91	CARBON 0.47	5% 1/4W F
<RELAY>			
RY601	Δ 1-755-032-11	RELAY	
<TRANSFORMER>			
T601	Δ 1-426-717-11	TRANSFORMER, LINE FILTER (LFT)	
T602	Δ 1-424-220-21	TRANSFORMER, LINE FILTER	
T603	Δ 1-427-864-12	TRANSFORMER, CONVERTER (PRT)	
T605	1-429-415-11	TRANSFORMER, CONVERTER (PIT)	
<THERMISTOR>			
THP601	Δ 1-809-539-11	THERMISTOR POSITIVE	
<VARISTOR>			
VDR601	1-810-974-21	VARISTOR	

* A-1331-522-A C BOARD, COMPLETE			

4-382-854-11 SCREW (M3X10), P, SW (+)			
<CAPACITOR>			
C1765	1-102-116-00	CERAMIC 680PF	10% 50V
C1766	1-102-117-00	CERAMIC 820PF	10% 50V
C1767	1-102-116-00	CERAMIC 680PF	10% 50V
C1775	1-102-116-00	CERAMIC 680PF	10% 50V
C1776	1-102-117-00	CERAMIC 820PF	10% 50V
C1777	1-102-116-00	CERAMIC 680PF	10% 50V
C1785	1-102-116-00	CERAMIC 680PF	10% 50V
C1786	1-102-117-00	CERAMIC 820PF	10% 50V
C1787	1-102-116-00	CERAMIC 680PF	10% 50V
C1790	1-102-129-00	CERAMIC 0.01MF	10% 50V
C1791	1-126-933-11	ELECT 100MF	20% 16V
C1793	1-107-651-11	ELECT 4.7MF	20% 250V
C1795	1-102-074-00	CERAMIC 0.001MF	10% 50V
C1797	1-106-375-12	MYLAR 0.022MF	200V
C1798	1-106-375-12	MYLAR 0.022MF	200V
C1799	1-162-114-00	CERAMIC 0.0047MF	2KV
<CONNECTOR>			
CN1761	* 1-564-509-11	PLUG, CONNECTOR 6P	
CN1762	1-508-784-00	PIN, CONNECTOR (5mm PITCH) 1P	
CN1764	* 1-564-507-11	PLUG, CONNECTOR 4P	
CN1766	1-695-915-11	TAB (CONTACT)	
<DIODE>			
D1761	8-719-991-33	DIODE 1SS133T-77	
D1762	8-719-991-33	DIODE 1SS133T-77	
D1763	8-719-991-33	DIODE 1SS133T-77	



Les composants identifiés par une trame et une marque Δ sont critiques pour la sécurité. Ne les remplacer que par une pièce portant le numéro spécifié.

The components identified by shading and mark Δ are critical for safety. Replace only with part number specified.

REF. NO.	PART NO.	DESCRIPTION	REMARK
D1771	8-719-991-33	DIODE 1SS133T-77	
D1772	8-719-991-33	DIODE 1SS133T-77	
D1773	8-719-991-33	DIODE 1SS133T-77	
D1781	8-719-991-33	DIODE 1SS133T-77	
D1782	8-719-991-33	DIODE 1SS133T-77	
D1783	8-719-991-33	DIODE 1SS133T-77	
D1790	8-719-991-33	DIODE 1SS133T-77	
D1792	8-719-983-14	DIODE MTZJ-T-77-3.9	

<JACK>

J1761	Δ 1-251-328-1	SOCKET, PICTURE TUBE	
-------	---------------	----------------------	--

<COIL>

L1790	1-410-667-31	INDUCTOR 22UH	
-------	--------------	---------------	--

<TRANSISTOR>

Q1761	8-729-119-78	TRANSISTOR 2SC2785-HFE	
Q1762	8-729-326-11	TRANSISTOR 2SC2611	
Q1763	8-729-200-17	TRANSISTOR 2SA1091-O	
Q1771	8-729-119-78	TRANSISTOR 2SC2785-HFE	
Q1772	8-729-326-11	TRANSISTOR 2SC2611	
Q1773	8-729-200-17	TRANSISTOR 2SA1091-O	
Q1781	8-729-119-78	TRANSISTOR 2SC2785-HFE	
Q1782	8-729-326-11	TRANSISTOR 2SC2611	
Q1783	8-729-200-17	TRANSISTOR 2SA1091-O	
Q1790	8-729-119-76	TRANSISTOR 2SA1175-HFE	

<RESISTOR>

R1760	1-260-105-11	CARBON	3.3K	5%	1/2W	
R1761	1-247-807-31	CARBON	100	5%	1/4W	
R1763	1-249-409-11	CARBON	220	5%	1/4W	F
R1764	Δ 1-216-486-5	METAL OXIDE	8.2K	5%	3W	F
R1765	1-249-411-11	CARBON	330	5%	1/4W	
R1766	1-249-393-11	CARBON	10	5%	1/4W	
R1767	1-249-429-11	CARBON	10K	5%	1/4W	
R1768	1-249-411-11	CARBON	330	5%	1/4W	
R1770	1-260-105-11	CARBON	3.3K	5%	1/2W	
R1771	1-247-807-31	CARBON	100	5%	1/4W	
R1773	1-249-409-11	CARBON	220	5%	1/4W	F
R1774	Δ 1-216-486-5	METAL OXIDE	8.2K	5%	3W	F
R1775	1-249-407-11	CARBON	150	5%	1/4W	
R1776	1-249-393-11	CARBON	10	5%	1/4W	
R1777	1-249-429-11	CARBON	10K	5%	1/4W	
R1780	1-260-105-11	CARBON	3.3K	5%	1/2W	
R1781	1-247-807-31	CARBON	100	5%	1/4W	
R1783	1-249-409-11	CARBON	220	5%	1/4W	F
R1784	Δ 1-216-486-5	METAL OXIDE	8.2K	5%	3W	F
R1785	1-249-407-11	CARBON	150	5%	1/4W	
R1786	1-249-393-11	CARBON	10	5%	1/4W	
R1787	1-249-429-11	CARBON	10K	5%	1/4W	
R1789	1-249-437-11	CARBON	47K	5%	1/4W	
R1792	1-247-815-91	CARBON	220	5%	1/4W	
R1793	1-247-863-91	CARBON	22K	5%	1/4W	
R1794	1-249-417-11	CARBON	1K	5%	1/4W	
R1795	1-260-087-11	CARBON	100	5%	1/2W	
R1796	Δ 1-216-365-5	METAL OXIDE	0.47	5%	2W	F
R1797	1-260-123-11	CARBON	100K	5%	1/2W	
R1798	1-260-133-11	CARBON	680K	5%	1/2W	
R1799	1-260-123-11	CARBON	100K	5%	1/2W	

<VARIABLE RESISTOR>

RV1791	1-230-641-11	RES, ADJ, METAL GLAZE 2.2M	
--------	--------------	----------------------------	--

REF. NO.	PART NO.	DESCRIPTION	REMARK
----------	----------	-------------	--------

* A-1372-209-A HS BOARD, COMPLETE

<CONNECTOR>

CN2101	1-564-524-11	PLUG, CONNECTOR 9P	
CN2102	1-564-523-11	PLUG, CONNECTOR 8P	

* A-1372-211-A WA BOARD, COMPLETE

4-382-854-11 SCREW (M3X10), P, SW (+)

<CAPACITOR>

C941	1-126-935-11	ELECT	470MF	20%	16V	
C944	1-164-232-11	CERAMIC CHIP	0.01MF	10%	50V	
C945	1-163-001-11	CERAMIC CHIP	220PF	10%	50V	
C946	1-126-933-11	ELECT	100MF	20%	16V	
C949	1-161-830-00	CERAMIC	0.0047MF		500V	
C950	1-126-933-11	ELECT	100MF	20%	16V	
C951	1-107-638-11	ELECT	33MF	20%	160V	
C952	1-106-391-12	MYLAR	0.1MF	10%	200V	
C953	1-106-383-00	MYLAR	0.047MF	10%	200V	
C954	1-137-364-11	FILM	0.001MF	5%	50V	
C955	1-107-667-11	ELECT	2.2MF	20%	160V	
C956	1-137-364-11	FILM	0.001MF	5%	50V	
C957	1-106-383-00	MYLAR	0.047MF	10%	200V	
C958	1-126-933-11	ELECT	100MF	20%	16V	
C961	1-163-251-11	CERAMIC CHIP	100PF	5%	50V	
C962	1-164-232-11	CERAMIC CHIP	0.01MF	10%	50V	
C965	1-163-035-00	CERAMIC CHIP	0.047MF		50V	
C966	1-163-009-11	CERAMIC CHIP	0.001MF	10%	50V	
C967	1-129-718-00	FILM	0.022MF	5%	630V	
C968	1-137-579-11	FILM	0.068MF	5%	100V	
C969	1-163-035-00	CERAMIC CHIP	0.047MF		50V	
C981	1-126-941-11	ELECT	470MF	20%	25V	
C983	1-137-366-11	FILM	0.0022MF	5%	50V	

<CONNECTOR>

CN941	1-564-511-11	PLUG, CONNECTOR 8P	
CN961	* 1-770-723-11	CONNECTOR, BOARD TO BOARD 8P	
CN981	* 1-564-506-11	PLUG, CONNECTOR 3P	

<DIODE>

D941	8-719-991-33	DIODE 1SS133T-77	
D946	8-719-110-88	DIODE RD39ESB2	
D947	8-719-110-88	DIODE RD39ESB2	
D961	8-719-109-89	DIODE RD5.6ESB2	
D962	8-719-991-33	DIODE 1SS133T-77	
D964	8-719-302-43	DIODE EL1Z	

<IC>

IC961	8-759-700-07	IC NJM2903M	
IC981	8-759-603-37	IC M5216P	

<COIL>

L962	1-406-989-21	COIL, CHOKE 10mH	
L963	1-406-675-11	COIL, CHOKE 4.7mH	

The components identified by shading and mark Δ are critical for safety. Replace only with part number specified.

Les composants identifiés par une trame et une marque Δ sont critiques pour la sécurité. Ne les remplacer que par une pièce portant le numéro spécifié.



REF. NO.	PART NO.	DESCRIPTION	REMARK
<TRANSISTOR>			
Q943	8-729-422-27	TRANSISTOR 2SD601A-Q	
Q944	8-729-422-27	TRANSISTOR 2SD601A-Q	
Q945	8-729-422-27	TRANSISTOR 2SD601A-Q	
Q946	8-729-017-05	TRANSISTOR 2SA1837	
Q947	8-729-017-06	TRANSISTOR 2SC4793	
Q962	8-729-931-45	TRANSISTOR IRF614	
Q963	8-729-216-22	TRANSISTOR 2SA1162-G	
Q965	8-729-422-27	TRANSISTOR 2SD601A-Q	
Q966	8-729-216-22	TRANSISTOR 2SA1162-G	
Q981	8-729-422-27	TRANSISTOR 2SD601A-Q	
<RESISTOR>			
R943	1-216-025-91	METAL GLAZE 100	5% 1/10W
R948	1-216-049-91	METAL GLAZE 1K	5% 1/10W
R949	1-216-049-91	METAL GLAZE 1K	5% 1/10W
R950	1-216-049-91	METAL GLAZE 1K	5% 1/10W
R951	1-216-049-91	METAL GLAZE 1K	5% 1/10W
R952	1-216-037-00	METAL GLAZE 330	5% 1/10W
R953	1-216-021-00	METAL GLAZE 68	5% 1/10W
R954	1-216-033-00	METAL GLAZE 220	5% 1/10W
R955	1-216-047-91	METAL GLAZE 820	5% 1/10W
R956	1-216-295-91	CONDUCTOR, CHIP	
R957	1-216-073-00	METAL GLAZE 10K	5% 1/10W
R958	1-216-295-91	CONDUCTOR, CHIP	
R959	1-216-021-00	METAL GLAZE 68	5% 1/10W
R960	1-216-689-11	METAL GLAZE 39K	5% 1/10W
R961	1-216-073-00	METAL GLAZE 10K	5% 1/10W
R962	1-216-057-00	METAL GLAZE 2.2K	5% 1/10W
R963	1-216-097-91	METAL GLAZE 100K	5% 1/10W
R964	1-216-073-00	METAL GLAZE 10K	5% 1/10W
R965	1-216-073-00	METAL GLAZE 10K	5% 1/10W
R966	1-216-097-91	METAL GLAZE 100K	5% 1/10W
R967	1-216-065-00	METAL GLAZE 4.7K	5% 1/10W
R968	1-216-083-00	METAL GLAZE 27K	5% 1/10W
R969	1-216-295-91	CONDUCTOR, CHIP	
R970	1-216-033-00	METAL GLAZE 220	5% 1/10W
R971	1-247-899-11	CARBON 680K	5% 1/4W
R972	1-216-073-00	METAL GLAZE 10K	5% 1/10W
R973	1-216-121-91	METAL GLAZE 1M	5% 1/10W
R974	1-216-073-00	METAL GLAZE 10K	5% 1/10W
R975	Δ 1-216-446-51	METAL OXIDE 18	5% 2W F
R976	Δ 1-216-423-51	METAL OXIDE 27	5% 1W F
R979	1-216-017-91	METAL GLAZE 47	5% 1/10W
R981	1-216-081-00	METAL GLAZE 22K	5% 1/10W
R982	1-216-081-00	METAL GLAZE 22K	5% 1/10W
R983	1-216-081-00	METAL GLAZE 22K	5% 1/10W
R984	1-216-081-00	METAL GLAZE 22K	5% 1/10W
R987	1-216-049-91	METAL GLAZE 1K	5% 1/10W
R988	1-216-295-91	CONDUCTOR, CHIP	
R989	1-216-304-11	METAL GLAZE 3.3	5% 1/10W
R992	1-216-073-00	METAL GLAZE 10K	5% 1/10W
R1941	1-260-311-11	CARBON 39	5% 1/2W
R1942	1-249-384-11	CARBON 1.8	5% 1/4W F
R1943	1-249-414-11	CARBON 560	5% 1/4W F
R1944	1-249-432-11	CARBON 18K	5% 1/4W
R1945	1-216-476-11	METAL OXIDE 180	5% 3W F
R1946	1-249-417-11	CARBON 1K	5% 1/4W F
R1947	1-249-432-11	CARBON 18K	5% 1/4W
R1948	1-249-414-11	CARBON 560	5% 1/4W
R1949	1-249-384-11	CARBON 1.8	5% 1/4W F
R1950	1-249-400-11	CARBON 39	5% 1/4W F

REF. NO.	PART NO.	DESCRIPTION	REMARK
* A-1372-207-A		HV BOARD, COMPLETE (KV-35V35)	*****
* A-1372-212-A		HV BOARD, COMPLETE	***** (KV-35V45/35V75)
<CAPACITOR>			
C2070	1-165-319-11	CERAMIC CHIP 0.1MF	50V
C2231	1-163-031-11	CERAMIC CHIP 0.01MF	50V (KV-35V45/35V75)
C2232	1-136-161-00	FILM 0.047MF	5% 50V (KV-35V45/35V75)
C2233	1-136-161-00	FILM 0.047MF	5% 50V
C2234	1-124-903-11	ELECT 1MF	20% 50V
C2235	1-124-903-11	ELECT 1MF	20% 50V
C2236	1-126-933-11	ELECT 100MF	20% 16V
<CONNECTOR>			
CN2002	* 1-564-518-11	PLUG, CONNECTOR 3P	(KV-35V45/35V75)
<DIODE>			
D2006	1-810-039-11	LED UNIT	
D2231	8-719-110-17	DIODE RD10ESB2	(KV-35V45/35V75)
D2232	8-719-110-17	DIODE RD10ESB2	(KV-35V45/35V75)
D2233	8-719-110-17	DIODE RD10ESB2	(KV-35V45/35V75)
D2236	8-719-110-17	DIODE RD10ESB2	
<IC>			
IC2003	8-747-905-11	IC SBX1790-51	
	8-747-905-11	RAY CATCHER ELEMENT	SBX1790-51 ; IC2003
IC2004	8-749-012-12	IC IS474	
<JACK>			
J2231	1-691-110-11	JACK, PIN 3P	
J2232	1-694-063-11	TERMINAL, S	(KV-35V45/35V75)
<TRANSISTOR>			
Q2008	8-729-216-22	TRANSISTOR 2SA1162-G	
Q2009	8-729-422-27	TRANSISTOR 2SD601A-Q	
<RESISTOR>			
R2009	1-216-033-00	METAL GLAZE 220	5% 1/10W
R2010	1-216-033-00	METAL GLAZE 220	5% 1/10W
R2011	1-216-025-91	METAL GLAZE 100	5% 1/10W
R2012	1-216-089-91	METAL GLAZE 47K	5% 1/10W
R2013	1-216-105-91	METAL GLAZE 220K	5% 1/10W
R2014	1-216-033-00	METAL GLAZE 220	5% 1/10W
R2015	1-247-807-31	CARBON 100	5% 1/4W
R2016	1-216-133-00	METAL GLAZE 3.3M	5% 1/10W
R2059	1-216-047-91	METAL GLAZE 820	5% 1/10W (KV-35V35)
R2060	1-216-049-91	METAL GLAZE 1K	5% 1/10W (KV-35V35)
R2061	1-216-055-00	METAL GLAZE 1.8K	5% 1/10W (KV-35V35)
R2062	1-216-065-00	METAL GLAZE 4.7K	5% 1/10W (KV-35V35)
R2063	1-216-073-00	METAL GLAZE 10K	5% 1/10W (KV-35V35)
R2231	1-216-022-00	METAL GLAZE 75	5% 1/10W (KV-35V45/35V75)
R2232	1-216-022-00	METAL GLAZE 75	5% 1/10W (KV-35V45/35V75)

UV

REF. NO.	PART NO.	DESCRIPTION	REMARK	REF. NO.	PART NO.	DESCRIPTION	REMARK
C242	1-124-902-00	ELECT	0.47MF 20% 50V			<JACK>	
C244	1-124-902-00	ELECT	0.47MF 20% 50V				
C245	1-126-941-11	ELECT	470MF 20% 25V (KV-35V45/35V75)	J231	1-750-515-11	TERMINAL BLOCK, S 3P	
				J232	1-750-517-11	JACK BLOCK, PIN 3P	
				J233	1-750-516-11	JACK BLOCK, PIN 2P	
				J234	1-750-517-11	JACK BLOCK, PIN 3P	
				J235	1-750-517-11	JACK BLOCK, PIN 3P (KV-35V45/35V75)	
C246	1-124-902-00	ELECT	0.47MF 20% 50V (KV-35V45/35V75)	J902	1-764-143-11	JACK 3P	
C247	1-124-902-00	ELECT	0.47MF 20% 50V (KV-35V45/35V75)	J903	1-764-143-11	JACK 3P	
C261	1-136-161-00	FILM	0.047MF 5% 50V	J904	1-764-143-11	JACK 3P	
C262	1-104-664-11	ELECT	47MF 20% 25V				
C263	1-136-161-00	FILM	0.047MF 5% 50V				
C264	1-126-933-11	ELECT	100MF 20% 16V (KV-35V35)			<CHIP CONDUCTOR>	
C264	1-126-952-11	ELECT	1000MF 20% 16V (KV-35V45/35V75)	JR151	1-216-295-91	CONDUCTOR, CHIP	
C265	1-104-664-11	ELECT	47MF 20% 25V	JR152	1-216-295-91	CONDUCTOR, CHIP	
C266	1-124-903-11	ELECT	1MF 20% 50V	JR201	1-216-295-91	CONDUCTOR, CHIP	
C267	1-124-903-11	ELECT	1MF 20% 50V	JR202	1-216-295-91	CONDUCTOR, CHIP	
				JR204	1-216-295-91	CONDUCTOR, CHIP	
C270	1-124-903-11	ELECT	1MF 20% 50V	JR205	1-216-295-91	CONDUCTOR, CHIP	
C271	1-124-903-11	ELECT	1MF 20% 50V	JR206	1-216-295-91	CONDUCTOR, CHIP	
C273	1-136-165-00	FILM	0.1MF 5% 50V	JR208	1-216-295-91	CONDUCTOR, CHIP	
C274	1-163-031-11	CERAMIC CHIP	0.01MF 50V	JR209	1-216-295-91	CONDUCTOR, CHIP	
C275	1-104-664-11	ELECT	47MF 20% 25V	JR210	1-216-295-91	CONDUCTOR, CHIP	
C301	1-126-933-11	ELECT	100MF 20% 16V (KV-35V35)	JR211	1-216-295-91	CONDUCTOR, CHIP	
C301	1-126-935-11	ELECT	470MF 20% 16V (KV-35V45/35V75)	JR212	1-216-295-91	CONDUCTOR, CHIP	
C901	1-124-903-11	ELECT	1MF 20% 50V (KV-35V45/35V75)	JR213	1-216-295-91	CONDUCTOR, CHIP	
				JR214	1-216-295-91	CONDUCTOR, CHIP	
				JR215	1-216-295-91	CONDUCTOR, CHIP	
				JR216	1-216-295-91	CONDUCTOR, CHIP	
				JR217	1-216-295-91	CONDUCTOR, CHIP	
				JR218	1-216-295-91	CONDUCTOR, CHIP	
				JR219	1-216-295-91	CONDUCTOR, CHIP	
				JR220	1-216-295-91	CONDUCTOR, CHIP	
				JR221	1-216-295-91	CONDUCTOR, CHIP	
				JR222	1-216-295-91	CONDUCTOR, CHIP	
				JR223	1-216-295-91	CONDUCTOR, CHIP	
				JR226	1-216-295-91	CONDUCTOR, CHIP	
				JR228	1-216-295-91	CONDUCTOR, CHIP	
						<TRANSISTOR>	
				Q231	8-729-422-27	TRANSISTOR 2SD601A-Q	
				Q232	8-729-422-27	TRANSISTOR 2SD601A-Q (KV-35V45/35V75)	
				Q233	8-729-422-27	TRANSISTOR 2SD601A-Q	
				Q234	8-729-422-27	TRANSISTOR 2SD601A-Q	
				Q235	8-729-422-27	TRANSISTOR 2SD601A-Q (KV-35V45/35V75)	
				Q236	8-729-422-27	TRANSISTOR 2SD601A-Q (KV-35V45/35V75)	
				Q237	8-729-216-22	TRANSISTOR 2SA1162-G	
				Q238	8-729-216-22	TRANSISTOR 2SA1162-G	
				Q239	8-729-216-22	TRANSISTOR 2SA1162-G	
				Q240	8-729-216-22	TRANSISTOR 2SA1162-G (KV-35V45/35V75)	
				Q241	8-729-216-22	TRANSISTOR 2SA1162-G (KV-35V45/35V75)	
				Q242	8-729-216-22	TRANSISTOR 2SA1162-G (KV-35V45/35V75)	
				Q243	8-729-216-22	TRANSISTOR 2SA1162-G	
				Q261	8-729-422-27	TRANSISTOR 2SD601A-Q	
				Q262	8-729-422-27	TRANSISTOR 2SD601A-Q	
				Q263	8-729-216-22	TRANSISTOR 2SA1162-G	
				Q265	8-729-216-22	TRANSISTOR 2SA1162-G	
						<RESISTOR>	
				R151	1-216-085-00	METAL GLAZE 33K	5% 1/10W
				R152	1-216-075-00	METAL GLAZE 12K	5% 1/10W
				R153	1-216-073-00	METAL GLAZE 10K	5% 1/10W
				R154	1-216-085-00	METAL GLAZE 33K	5% 1/10W
				R155	1-216-075-00	METAL GLAZE 12K	5% 1/10W
				R156	1-216-073-00	METAL GLAZE 10K	5% 1/10W
				R157	1-216-079-00	METAL GLAZE 18K	5% 1/10W
				R158	1-216-073-00	METAL GLAZE 10K	5% 1/10W
				R159	1-216-073-00	METAL GLAZE 10K	5% 1/10W
				R160	1-216-079-00	METAL GLAZE 18K	5% 1/10W
						<IC>	
IC151	8-759-700-44	IC NJM2902M					
IC152	8-759-700-44	IC NJM2902M					
IC153	8-759-100-96	IC uPC4558G2					
IC154	8-759-068-07	IC CD4052BCN					
IC261	8-759-366-78	IC MM1313AD					



REF. NO.	PART NO.	DESCRIPTION	REMARK	REF. NO.	PART NO.	DESCRIPTION	REMARK
R161	1-216-073-00	METAL GLAZE 10K	5% 1/10W	R225	1-247-815-91	CARBON 220	5% 1/4W
R162	1-216-073-00	METAL GLAZE 10K	5% 1/10W	R226	1-247-815-91	CARBON 220	5% 1/4W
R163	1-216-073-00	METAL GLAZE 10K	5% 1/10W	R227	1-249-440-11	CARBON 82K	5% 1/4W
R164	1-249-425-11	CARBON 4.7K	5% 1/4W	R228	1-216-033-00	METAL GLAZE 220	5% 1/10W
R165	1-216-073-00	METAL GLAZE 10K	5% 1/10W	R229	1-216-025-91	METAL GLAZE 100	5% 1/10W
R166	1-216-049-91	METAL GLAZE 1K	5% 1/10W	R230	1-216-033-00	METAL GLAZE 220	5% 1/10W
R167	1-216-065-00	METAL GLAZE 4.7K	5% 1/10W	R231	1-216-022-00	METAL GLAZE 75	5% 1/10W
R168	1-216-077-00	METAL GLAZE 15K	5% 1/10W	R232	1-216-022-00	METAL GLAZE 75	5% 1/10W
R169	1-216-099-00	METAL GLAZE 120K	5% 1/10W	R233	1-216-065-00	METAL GLAZE 4.7K	5% 1/10W
R170	1-216-049-91	METAL GLAZE 1K	5% 1/10W	R234	1-216-022-00	METAL GLAZE 75	5% 1/10W
R171	1-216-049-91	METAL GLAZE 1K	5% 1/10W	R235	1-216-113-00	METAL GLAZE 470K	5% 1/10W
R172	1-216-057-00	METAL GLAZE 2.2K	5% 1/10W	R236	1-216-065-00	METAL GLAZE 4.7K	5% 1/10W
R173	1-216-065-00	METAL GLAZE 4.7K	5% 1/10W	R237	1-216-113-00	METAL GLAZE 470K	5% 1/10W
R174	1-216-081-00	METAL GLAZE 22K	5% 1/10W	R238	1-216-065-00	METAL GLAZE 4.7K	5% 1/10W
R175	1-216-081-00	METAL GLAZE 22K	5% 1/10W	R239	1-216-022-00	METAL GLAZE 75	5% 1/10W
R176	1-216-081-00	METAL GLAZE 22K	5% 1/10W	R240	1-216-113-00	METAL GLAZE 470K	5% 1/10W
R177	1-216-049-91	METAL GLAZE 1K	5% 1/10W	R241	1-216-065-00	METAL GLAZE 4.7K	5% 1/10W
R178	1-216-065-00	METAL GLAZE 4.7K	5% 1/10W	R242	1-216-113-00	METAL GLAZE 470K	5% 1/10W
R179	1-216-065-00	METAL GLAZE 4.7K	5% 1/10W	R243	1-216-065-00	METAL GLAZE 4.7K	5% 1/10W
R180	1-216-099-00	METAL GLAZE 120K	5% 1/10W	R244	1-216-113-00	METAL GLAZE 470K	5% 1/10W
R181	1-216-049-91	METAL GLAZE 1K	5% 1/10W	R245	1-249-417-11	CARBON 1K	5% 1/4W
R183	1-216-081-00	METAL GLAZE 22K	5% 1/10W	R246	1-216-113-00	METAL GLAZE 470K	5% 1/10W
R184	1-216-081-00	METAL GLAZE 22K	5% 1/10W	R247	1-249-417-11	CARBON 1K	5% 1/4W
R185	1-216-081-00	METAL GLAZE 22K	5% 1/10W	R248	1-216-021-00	METAL GLAZE 68	5% 1/10W
R186	1-216-089-91	METAL GLAZE 47K	5% 1/10W	R249	1-216-113-00	METAL GLAZE 470K	5% 1/10W
R187	1-216-099-00	METAL GLAZE 120K	5% 1/10W	R250	1-216-113-00	METAL GLAZE 470K	5% 1/10W
R188	1-216-097-91	METAL GLAZE 100K	5% 1/10W	R251	1-216-113-00	METAL GLAZE 470K	5% 1/10W
R189	1-216-097-91	METAL GLAZE 100K	5% 1/10W	R252	1-216-019-00	METAL GLAZE 56	5% 1/10W
R190	1-216-081-00	METAL GLAZE 22K	5% 1/10W	R253	1-216-113-00	METAL GLAZE 470K	(KV-35V45/35V75) 5% 1/10W
R191	1-216-089-91	METAL GLAZE 47K	5% 1/10W				(KV-35V45/35V75)
R192	1-216-063-91	METAL GLAZE 3.9K	5% 1/10W	R254	1-216-113-00	METAL GLAZE 470K	5% 1/10W
R193	1-216-075-00	METAL GLAZE 12K	5% 1/10W				(KV-35V45/35V75)
R194	1-216-099-00	METAL GLAZE 120K	5% 1/10W	R255	1-216-113-00	METAL GLAZE 470K	5% 1/10W
R195	1-216-097-91	METAL GLAZE 100K	5% 1/10W				(KV-35V45/35V75)
R196	1-216-089-91	METAL GLAZE 47K	5% 1/10W	R256	1-216-069-00	METAL GLAZE 6.8K	5% 1/10W
R197	1-216-097-91	METAL GLAZE 100K	5% 1/10W	R258	1-216-069-00	METAL GLAZE 6.8K	5% 1/10W
R198	1-216-081-00	METAL GLAZE 22K	5% 1/10W				(KV-35V45/35V75)
R199	1-216-089-91	METAL GLAZE 47K	5% 1/10W	R259	1-216-065-00	METAL GLAZE 4.7K	5% 1/10W
R200	1-216-081-00	METAL GLAZE 22K	5% 1/10W	R260	1-247-807-31	CARBON 100	5% 1/4W
R201	1-216-065-00	METAL GLAZE 4.7K	5% 1/10W	R261	1-216-009-00	METAL GLAZE 22	5% 1/10W
R202	1-216-049-91	METAL GLAZE 1K	5% 1/10W	R264	1-247-815-91	CARBON 220	5% 1/4W
R203	1-216-069-00	METAL GLAZE 6.8K	5% 1/10W	R265	1-247-815-91	CARBON 220	5% 1/4W
R204	1-216-069-00	METAL GLAZE 6.8K	5% 1/10W	R266	1-216-043-91	METAL GLAZE 560	5% 1/10W
R206	1-216-049-91	METAL GLAZE 1K	5% 1/10W	R267	1-249-415-11	CARBON 680	5% 1/4W
R207	1-216-295-91	CONDUCTOR, CHIP	(KV-35V45/35V75)	R268	1-216-025-91	METAL GLAZE 100	5% 1/10W
R208	1-216-049-91	METAL GLAZE 1K	5% 1/10W	R269	1-216-025-91	METAL GLAZE 100	5% 1/10W
R209	1-216-069-00	METAL GLAZE 6.8K	5% 1/10W	R270	1-216-041-00	METAL GLAZE 470	5% 1/10W
R210	1-216-069-00	METAL GLAZE 6.8K	5% 1/10W	R271	1-249-415-11	CARBON 680	5% 1/4W
R212	1-249-440-11	CARBON 82K	5% 1/4W	R272	1-249-417-11	CARBON 1K	5% 1/4W
R213	1-216-065-00	METAL GLAZE 4.7K	5% 1/10W	R274	1-249-413-11	CARBON 470	5% 1/4W
R214	1-216-065-00	METAL GLAZE 4.7K	5% 1/10W	R275	1-249-425-11	CARBON 4.7K	5% 1/4W
R215	1-249-413-11	CARBON 470	5% 1/4W	R276	1-249-425-11	CARBON 4.7K	5% 1/4W
R216	1-216-025-91	METAL GLAZE 100	5% 1/10W	R277	1-216-049-91	METAL GLAZE 1K	5% 1/10W
R217	1-216-025-91	METAL GLAZE 100	5% 1/10W	R278	1-249-413-11	CARBON 470	5% 1/4W
R218	1-216-025-91	METAL GLAZE 100	5% 1/10W				(KV-35V45/35V75)
R219	1-216-065-00	METAL GLAZE 4.7K	5% 1/10W	R279	1-216-025-91	METAL GLAZE 100	5% 1/10W
R220	1-216-065-00	METAL GLAZE 4.7K	5% 1/10W	R280	1-216-033-00	METAL GLAZE 220	5% 1/10W
R221	1-249-413-11	CARBON 470	5% 1/4W	R281	1-216-033-00	METAL GLAZE 220	5% 1/10W
R222	1-216-025-91	METAL GLAZE 100	5% 1/10W	R282	1-216-025-91	METAL GLAZE 100	5% 1/10W
R223	1-216-025-91	METAL GLAZE 100	5% 1/10W	R283	1-216-025-91	METAL GLAZE 100	5% 1/10W
R224	1-216-025-91	METAL GLAZE 100	5% 1/10W	R284	1-216-065-00	METAL GLAZE 4.7K	5% 1/10W
			(KV-35V45/35V75)	R285	1-216-065-00	METAL GLAZE 4.7K	5% 1/10W
			(KV-35V45/35V75)	R286	1-249-417-11	CARBON 1K	5% 1/4W
			(KV-35V45/35V75)	R288	1-247-815-91	CARBON 220	5% 1/4W
			(KV-35V45/35V75)	R289	1-247-815-91	CARBON 220	5% 1/4W
			(KV-35V45/35V75)	R290	1-247-815-91	CARBON 220	5% 1/4W
			(KV-35V45/35V75)	R291	1-216-025-91	METAL GLAZE 100	5% 1/10W
			(KV-35V45/35V75)	R293	1-216-025-91	METAL GLAZE 100	5% 1/10W
			(KV-35V45/35V75)	R294	1-216-049-91	METAL GLAZE 1K	5% 1/10W

The components identified by shading and mark **△** are critical for safety. Replace only with part number specified.

Les composants identifiés par une trame et une marque **△** sont critiques pour la sécurité. Ne les remplacer que par une pièce portant le numéro spécifié.



REF. NO.	PART NO.	DESCRIPTION	REMARK
R301	1-249-417-11	CARBON 1K	5% 1/4W
R304	1-249-417-11	CARBON 1K	5% 1/4W
R902	1-249-405-11	CARBON 100	5% 1/4W F
R919	1-216-295-91	CONDUCTOR, CHIP	
R920	1-249-405-11	CARBON 100	5% 1/4W F
R921	1-249-405-11	CARBON 100	5% 1/4W F
R922	1-216-049-91	METAL GLAZE 1K	5% 1/10W
R923	1-216-049-91	METAL GLAZE 1K	5% 1/10W
R924	1-216-049-91	METAL GLAZE 1K	5% 1/10W
R1151	1-216-053-00	METAL GLAZE 1.5K	5% 1/10W
R1152	1-216-049-91	METAL GLAZE 1K	5% 1/10W
R1153	1-216-089-91	METAL GLAZE 47K	5% 1/10W
R1154	1-216-049-91	METAL GLAZE 1K	5% 1/10W
R1155	1-216-089-91	METAL GLAZE 47K	5% 1/10W
R1156	1-216-073-00	METAL GLAZE 10K	5% 1/10W
R1157	1-216-073-00	METAL GLAZE 10K	5% 1/10W
R1158	1-216-065-00	METAL GLAZE 4.7K	5% 1/10W
R1159	1-216-065-00	METAL GLAZE 4.7K	5% 1/10W
R1160	1-216-295-91	CONDUCTOR, CHIP	
R1161	1-216-295-91	CONDUCTOR, CHIP	
R1164	1-216-049-91	METAL GLAZE 1K	5% 1/10W
R1165	1-216-049-91	METAL GLAZE 1K	5% 1/10W
R1166	1-216-049-91	METAL GLAZE 1K	5% 1/10W
R1167	1-216-049-91	METAL GLAZE 1K	5% 1/10W
R1168	1-216-049-91	METAL GLAZE 1K	5% 1/10W

REF. NO.	PART NO.	DESCRIPTION	REMARK
ACCESSORIES AND PACKING MATERIALS *****			
	2-352-981-01	SPACER (KV-35V75)	
	2-359-505-01	RETAINER, MAGNET (KV-35V75)	
	3-701-627-00	BAG, POLYETHYLENE	
	3-810-687-21	MANUAL, INSTRUCTION	
	3-810-687-31	MANUAL, INSTRUCTION (KV-35V35(CND)/KV-35V45)	
*	4-030-895-01	JOINT (KV-35V75)	
*	4-041-423-01	SHEET, PROTECTION (KV-35V75)	
	4-049-536-01	HINGE SET (KV-35V75)	
*	4-052-909-01	BOTTOM BOARD (KV-35V75)	
*	4-052-910-01	CUSHION (UPPER) (ASSY) (KV-35V75)	
*	4-052-911-01	CUSHION (LOWER) (ASSY) (KV-35V75)	
*	4-052-913-01	TRAY (KV-35V75)	
*	4-052-914-01	CARTON, INDIVIDUAL (KV-35V75)	
*	4-053-276-01	INDIVIDUAL CARTON (KV-35V35/KV-35V45)	
*	4-053-277-01	CUSHION (UPPER) (ASSY) (KV-35V35/KV-35V45)	
*	4-053-278-01	CUSHION (LOWER) (ASSY) (KV-35V35/KV-35V45)	
*	4-053-658-01	BAG, PROTECTION (KV-35V35/KV-35V45)	
*	4-053-842-01	PROTECTION, BAG, (KV-35V75)	

REMOTE COMMANDER

8-917-534-90 REMOTE COMMANDER RM-Y137//M
4-978-977-01 POCKET, COVER (FOR RM-Y137)

* 1-659-757-11 SA BOARD

MISCELLANEOUS

△ 1-411-881-11	COIL, DEMAGNETIC
△ 1-411-882-11	COIL, DEMAGNETIC
1-473-549-11	SWITCH BLOCK, CONTROL (KV-35V45/KV-35V75)
* 1-556-945-21	CABLE, P-P
* 1-557-056-31	CABLE, P-P
△ 1-751-059-11	CORD, POWER (WITH CONNECTOR) 10A/125V
8-453-007-11	NA324-M
8-598-358-00	CHANGER, ANTENNA AS-2K
△ 8-451-480-11	DEFLECTION YOKE (Y37GXA-X)
△ 8-733-760-05	PICTURE TUBE (A89LIT80X)
