

# TOSHIBA

FILE NO. 050-200403

## SERVICE MANUAL

## COLOR TELEVISION

# 14AF44

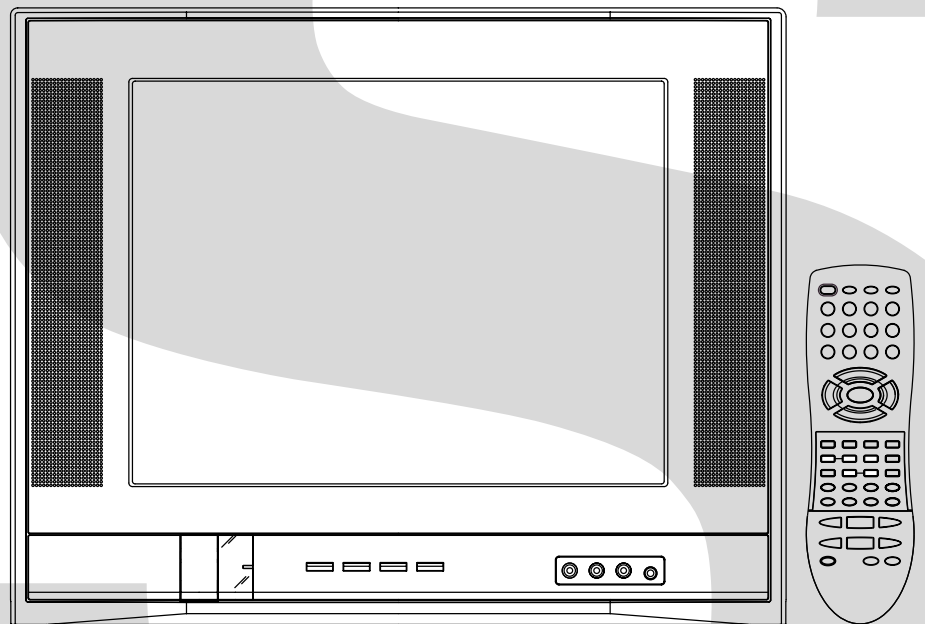

## SERVICING NOTICES ON CHECKING

### 1. KEEP THE NOTICES

As for the places which need special attentions, they are indicated with the labels or seals on the cabinet, chassis and parts. Make sure to keep the indications and notices in the operation manual.

### 2. AVOID AN ELECTRIC SHOCK

There is a high voltage part inside. Avoid an electric shock while the electric current is flowing.

### 3. USE THE DESIGNATED PARTS

The parts in this equipment have the specific characters of incombustibility and withstand voltage for safety. Therefore, the part which is replaced should be used the part which has the same character.

Especially as to the important parts for safety which is indicated in the circuit diagram or the table of parts as a  mark, the designated parts must be used.

### 4. PUT PARTS AND WIRES IN THE ORIGINAL POSITION AFTER ASSEMBLING OR WIRING

There are parts which use the insulation material such as a tube or tape for safety, or which are assembled in the condition that these do not contact with the printed board. The inside wiring is designed not to get closer to the pyrogenic parts and high voltage parts. Therefore, put these parts in the original positions.

### 5. TAKE CARE TO DEAL WITH THE CATHODE-RAY TUBE

In the condition that an explosion-proof cathode-ray tube is set in this equipment, safety is secured against implosion. However, when removing it or serving from backward, it is dangerous to give a shock. Take enough care to deal with it.

### 6. AVOID AN X-RAY

Safety is secured against an X-ray by considering about the cathode-ray tube and the high voltage peripheral circuit, etc.

Therefore, when repairing the high voltage peripheral circuit, use the designated parts and make sure not modify the circuit.

Repairing except indicates causes rising of high voltage, and it emits an X-ray from the cathode-ray tube.

### 7. PERFORM A SAFETY CHECK AFTER SERVICING

Confirm that the screws, parts and wiring which were removed in order to service are put in the original positions, or whether there are the portions which are deteriorated around the serviced places serviced or not. Check the insulation between the antenna terminal or external metal and the AC cord plug blades. And be sure the safety of that.

#### (INSULATION CHECK PROCEDURE)

1. Unplug the plug from the AC outlet.
2. Remove the antenna terminal on TV and turn on the TV.
3. Insulation resistance between the cord plug terminals and the external exposure metal **[Note 2]** should be more than 1M ohm by using the 500V insulation resistance meter **[Note 1]**.
4. If the insulation resistance is less than 1M ohm, the inspection repair should be required.

#### **[Note 1]**

If you have not the 500V insulation resistance meter, use a Tester.

#### **[Note 2]**

External exposure metal: Antenna terminal  
Headphone jack

## HOW TO ORDER PARTS

Please include the following informations when you order parts. (Particularly the VERSION LETTER.)

#### 1. MODEL NUMBER and VERSION LETTER

The MODEL NUMBER can be found on the back of each product and the VERSION LETTER can be found at the end of the SERIAL NUMBER.

#### 2. PART NO. and DESCRIPTION

You can find it in your SERVICE MANUAL.

## IMPORTANT

Inferior silicon grease can damage IC's and transistors.

When replacing an IC's or transistors, use only specified silicon grease (YG6260M).

Remove all old silicon before applying new silicon.

# TABLE OF CONTENTS

<b>SERVICING NOTICES ON CHECKING</b> .....	A1-1
<b>HOW TO ORDER PARTS</b> .....	A1-1
<b>IMPORTANT</b> .....	A1-1
<b>TABLE OF CONTENTS</b> .....	A2-1
<b>GENERAL SPECIFICATIONS</b> .....	A3-1~A3-5
<b>DISASSEMBLY INSTRUCTIONS</b>	
1. REMOVAL OF ANODE CAP .....	B1-1
2. REMOVAL AND INSTALLATION OF FLAT PACKAGE IC .....	B2-1, B2-2
<b>SERVICE MODE LIST</b> .....	C1-1
<b>CONFIRMATION OF HOURS USED</b> .....	C1-1
<b>WHEN REPLACING EEPROM (MEMORY) IC</b> .....	C1-1
<b>ELECTRICAL ADJUSTMENTS</b> .....	D-1~D-5
<b>BLOCK DIAGRAM</b> .....	E-1, E-2
<b>PRINTED CIRCUIT BOARDS</b>	
MAIN/CRT .....	F-1~F-4
<b>SCHEMATIC DIAGRAMS</b>	
MICON .....	G-1, G-2
CHROMA .....	G-3, G-4
DEFLECTION/CRT .....	G-5, G-6
POWER .....	G-7, G-8
SOUND .....	G-9, G-10
TUNER/STEREO .....	G-11, G-12
AV .....	G-13, G-14
COMB/FILTER .....	G-15, G-16
CRT/SVM .....	G-17, G-18
<b>WAVEFORMS</b> .....	H-1, H-2
<b>MECHANICAL EXPLODED VIEWS</b> .....	I-1, I-2
<b>MECHANICAL REPLACEMENT PARTS LIST</b> .....	J1-1
<b>ELECTRICAL REPLACEMENT PARTS LIST</b> .....	J2-1~J2-4

## GENERAL SPECIFICATIONS

<b>G-1</b>	<b>TV System</b>	CRT	CRT Size / Visual Size	14 inch / 357mmV	
			CRT Type	Flat	
			Deflection	90 degree	
			Magnetic Field BV/BH	+0.45G/0.18G	
			Color System	NTSC	
			Speaker	2 Speaker	
				Position	Front Side
				Size	1.6 x 2.8 Inch
				Impedance	8 ohm
			Sound Output	MAX	2.5+2.5 W
		10%(Typical)	2.0+2.0 W		
		NTSC3.58+4.43 /PAL60Hz	No		
<b>G-2</b>	<b>Tuning System</b>	Broadcasting System		US System M	
		Tuner and Receive CH	System	1Tuner	
			Destination	USA(W/ CATV)	
			Tuning System	F-Synth	
			Input Impedance	VHF/UHF 75 ohm	
				CH Coverage	2 - 69, 4A, A-5 - A-1, A - I, J - W, W+1 - W+84
			Intermediate Frequency	Picture(FP)	45.75MHz
				Sound(FS)	41.25MHz
				FP-FS	4.50MHz
			Preset CH		No
<b>G-3</b>	<b>Power</b>	Power Source	AC	120V AC 60Hz	
			DC		
		Power Consumption		at AC	
			Stand by (at AC)		80 W at AC 120 V 60 Hz
			Per Year		3 W at AC 120 V 60 Hz
			-- kWh/Year		
	Protector	Power Fuse	Yes		
		Safety Circuit	Yes		
		IC Protector(Micro Fuse)	No		
<b>G-4</b>	<b>Regulation</b>	Safety		UL/CSA	
		Radiation		FCC/IC	
		X-Radiation		DHHS/HWC	
<b>G-5</b>	<b>Temperature</b>	Operation		+5oC ~ +40oC	
		Storage		-20oC ~ +60oC	
<b>G-6</b>	<b>Operating Humidity</b>			Less than 80% RH	

# GENERAL SPECIFICATIONS

G-7	On Screen Display	Menu		Yes	
			Menu Type	Icon	
			Picture	Yes	
				Contrast	Yes
				Brightness	Yes
				Color	Yes
				Tint	Yes
				Sharpness	Yes
				Audio	Yes
				Bass	Yes
				Treble	Yes
				Balance	Yes
				Stable Sound On/Off	Yes
				Surround On/Off	Yes
				Set Up	Yes
				TV/CATV	Yes
				Auto CH Memory	Yes
				Add/ Delete	Yes
				Option	Yes
				Language	Yes
				CH Label	Yes
				Favorite CH	Yes
				V-Chip	Yes
				Lock	Yes
				On/Off Timer	Yes
				Color Stream DVD/DTV	Yes
				Control Level	Yes
				Volume	Yes
				Brightness	Yes
				Contrast	Yes
				Color	Yes
				Tint	Yes
				Sharpness	Yes
		Tuning	No		
		Bass	Yes		
		Treble	Yes		
		Balance	Yes		
		Back Light	No		
		Stereo,Audio Output,SAP	Yes		
		Video	Yes		
		Color Stream	Yes		
		Channel(TV/Cable)	Yes		
		CH Label	Yes		
		Game Timer	Yes		
		Sleep Timer	Yes		
		Sound Mute	Yes		
		V-chip Rating	Yes		
		16: 9	Yes		
G-8	OSD Language			English French Spanish	
G-9	Clock and Timer	Sleep Timer	Max Time	120 Min	
			Step	10 Min	
		On/Off Timer	Program(On Timer / Off Timer / Clock)	Yes	
		Wake Up Timer		No	
		Timer Back-up (at Power Off Mode)	more than	-- Min Sec	

# GENERAL SPECIFICATIONS

<b>G-10</b>	<b>Remote Control</b>	Unit	RC-GW		
		Glow in Dark Remocon	Yes		
		Format	Toshiba		
		Custom Code	TV:40-BF h		
		Power Source	Voltage(D.C) UM size x pcs	3V UM-4 x 2 pcs	
		Total Keys		50 Keys	
		Keys	Power	Yes	
			1	Yes	
			2	Yes	
			3	Yes	
			4	Yes	
			5	Yes	
			6	Yes	
			7	Yes	
			8	Yes	
			9	Yes	
			0	Yes	
			100	Yes	
			CH Up	Yes	
			CH Down	Yes	
			Volume Up	Yes	
			Volume Down	Yes	
			TV/Caption/Text	Yes	
			CH1/CH2	Yes	
			TV/Video(TV/AV)	Yes	
			CH RTN/CH ENT(Quick View)	Yes	
			Sleep	Yes	
			RE Call(Call)	Yes	
			Reset	Yes	
			Menu/Enter	Yes	
			Mute	Yes	
			Exit	Yes	
			MTS(Audio Select)	Yes	
			Fav.Up	Yes	
			Fav.Down	Yes	
			16: 9	Yes	
			Multi Brand Keys	CH Up(VCR)	Yes
				CH Down(VCR)	Yes
				Pause/Still	Yes
				TV/VCR(VCR)	Yes
				FF	Yes
				Rew	Yes
		Rec		Yes	
		Play		Yes	
		Stop		Yes	
		TV		Yes	
		VCR		Yes	
		Cable		Yes	
		DVD		Yes	
		CODE		Yes	
Volume Up(DVD)	Yes				
Volume Down(DVD)	Yes				
DVD CLEAR	Yes				
TOP MENU	Yes				
DVD MENU	Yes				
DISPLAY	Yes				

## GENERAL SPECIFICATIONS

<b>G-11</b>	<b>Features</b>	Auto Degauss	Yes
		Auto Shut Off	Yes
		Canal+	No
		CATV	Yes
		Anti-theft	No
		Rental	No
		Memory(Last CH)	Yes
		Memory(Last Volume)	Yes
		V-Chip	Yes
		Type	USA, Toshiba Type
		BBE	No
		Auto Search	No
		CH Allocation	No
		SAP	Yes
		Just Clock Function	No
		CH Label	Yes
		VM Circuit	No
		Full OSD	No
		Premiere	No
		Comb Filter	Yes 3 Lines
		Auto CH Memory	Yes
		Hotel Lock	No
		Closed Caption	Yes
		Stable Sound	Yes
		FBT Leak Test Protect	Yes
		CH Lock	Yes
		Video Lock	Yes
		Game Timer (Max Time:120 Min)	Yes
		Energy Star	No
		Favorite CH	Yes
		Surround	Yes
		16:9 Mode	Yes
		<b>G-12</b>	<b>Accessories</b>
W/ Warranty	Yes		
Remote Control Unit	Yes		
Rod Antenna	No		
Poles			
Terminal			
Loop Antenna	No		
Terminal	-		
U/V Mixer	No		
DC Car Cord (Center+)	No		
Guarantee Card	No		
Warning Sheet	No		
Circuit Diagram	No		
Antenna Change Plug	No		
Service Station List	No		
Important Safety Instructions	No		
Dew/AHC Caution Sheet	No		
AC Plug Adapter	No		
Quick Set-up Sheet	No		
Battery	Yes UM-4 x 2		
UM size x pcs	No		
OEM Brand	No		
AC Cord	No		
AV Cord (2Pin-1Pin)	No		
Registration Card (NDL Card)	Yes		
PTB Sheet	No		
ESP Card	No[From '04 MAR O/R]		
300 ohm to 75 ohm Antenna Adapter	No		

## GENERAL SPECIFICATIONS

<b>G-13</b>	<b>Interface</b>	Switch	Front	Power	Yes	
				System Select	No	
				Main Power SW	No	
				Sub Power	No	
				Channel Up	Yes	
				Channel Down	Yes	
				Volume Up	Yes	
				Volume Down	Yes	
				Rear	AC/DC	No
					TV/CATV Selector	No
		Degauss	No			
		Main Power SW	No			
		Indicator	Power	Yes(RED)		
			Stand-by	No		
			On Timer	No		
		Terminals	Front	Video Input = VIDEO3	RCA	
				Audio Input = VIDEO3	RCA x 2	
				Other Terminal	Head Phone	
			Rear	Video Input(Rear1) = VIDEO1	RCA	
				Video Input(Rear2) = VIDEO2	RCA	
				Audio Input(Rear1) = VIDEO1	RCA x 2	
				Audio Input(Rear2) = VIDEO2	RCA x 2	
				Video Output	No	
				Audio Output	No	
				Euro Scart	No	
				Color Stream	RCA x 3	
S Input	Yes					
Diversity	No					
Ext Speaker	No					
DC Jack 12V(Center +)	No					
VHF/UHF Antenna Input	F Type					
AC Outlet	No					
<b>G-14</b>	<b>Set Size</b>			Approx. W x D x H (mm)		432 x 386 x 344.5
<b>G-15</b>	<b>Weight</b>			Net (Approx.)		11.0kg (24.3 lbs)
				Gross (Approx.)		13.0 kg (28.7 lbs)
<b>G-16</b>	<b>Carton</b>	Master Carton		No		
			Content	--- Sets		
			Material	-- /--		
			Dimensions W x D x H(mm)	-- x -- x --		
			Description of Origin	--		
		Gift Box		Yes		
			Material	Double/Brown		
			Dimensions W x D x H(mm)	540 x 460 x 465		
			Design	As per Buyer's		
		Drop Test	Description of Origin	Yes		
				Natural Dropping At 1 Corner / 3 Edges / 6 Surfaces		
Height (cm)	62					
Container Stuffing		550 Sets/40' container				
<b>G-17</b>	<b>Cabinet Material</b>	Cabinet	Cabinet Front	PS 94V0 DECABROM		
			Cabinet Rear	PS 94V0 DECABROM		
		PCB	Non-Halogen Demand	No		
			Eyelet Demand	Yes		
<b>G-18</b>	<b>Environment</b>	Pb Free	Lead-free Solder	No		
		Cd Free		No		

# DISASSEMBLY INSTRUCTIONS

## 1. REMOVAL OF ANODE CAP

Read the following **NOTED** items before starting work.

- \* After turning the power off there might still be a potential voltage that is very dangerous. When removing the Anode Cap, make sure to discharge the Anode Cap's potential voltage.
- \* Do not use pliers to loosen or tighten the Anode Cap terminal, this may cause the spring to be damaged.

### REMOVAL

1. Follow the steps as follows to discharge the Anode Cap. (Refer to Fig. 1-1.)

Connect one end of an Alligator Clip to the metal part of a flat-blade screwdriver and the other end to ground. While holding the plastic part of the insulated Screwdriver, touch the support of the Anode with the tip of the Screwdriver. A cracking noise will be heard as the voltage is discharged.

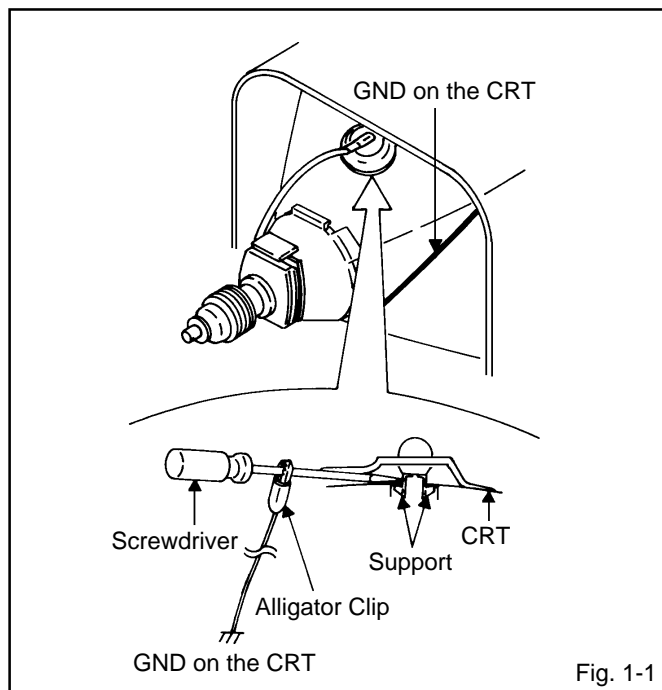

2. Flip up the sides of the Rubber Cap in the direction of the arrow and remove one side of the support. (Refer to Fig. 1-2.)

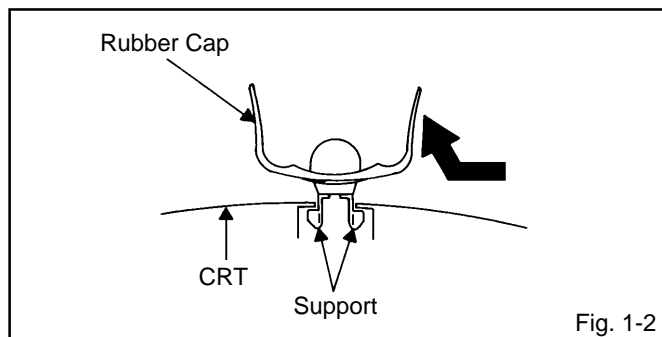

3. After one side is removed, pull in the opposite direction to remove the other.

### NOTE

Take care not to damage the Rubber Cap.

### INSTALLATION

1. Clean the spot where the cap was located with a small amount of alcohol. (Refer to Fig. 1-3.)

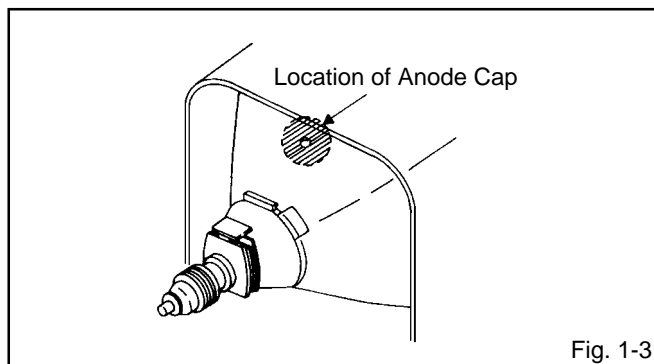

### NOTE

Confirm that there is no dirt, dust, etc. at the spot where the cap was located.

2. Arrange the wire of the Anode Cap and make sure the wire is not twisted.
3. Turn over the Rubber Cap. (Refer to Fig. 1-4.)

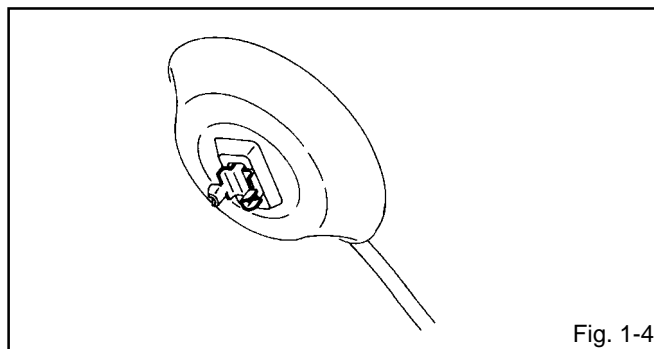

4. Insert one end of the Anode Support into the anode button, then the other as shown in Fig. 1-5.

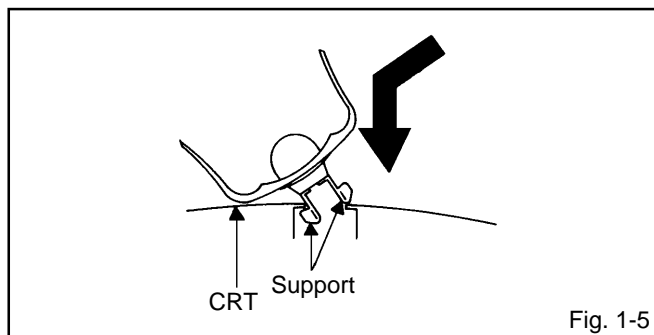

5. Confirm that the Support is securely connected.
6. Put on the Rubber Cap without moving any parts.

# DISASSEMBLY INSTRUCTIONS

## 2. REMOVAL AND INSTALLATION OF FLAT PACKAGE IC

### REMOVAL

1. Put the Masking Tape (cotton tape) around the Flat Package IC to protect other parts from any damage. (Refer to Fig. 2-1.)

#### NOTE

Masking is carried out on all the parts located within 10 mm distance from IC leads.

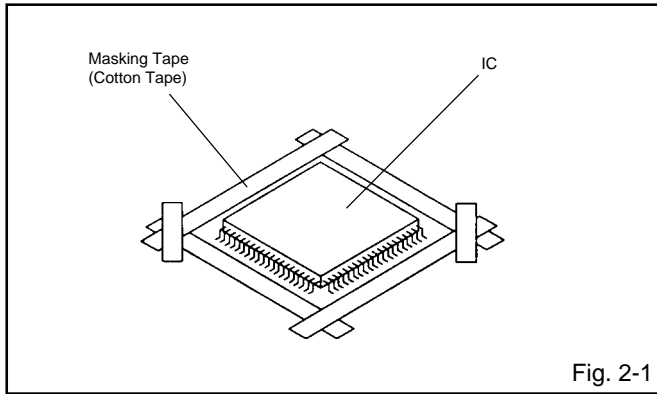

2. Heat the IC leads using a blower type IC desoldering machine. (Refer to Fig. 2-2.)

#### NOTE

Do not add the rotating and the back and forth directions force on the IC, until IC can move back and forth easily after desoldering the IC leads completely.

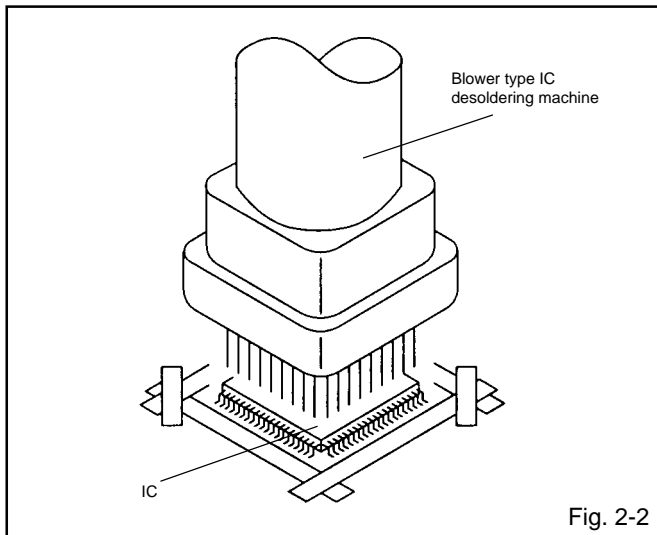

3. When IC starts moving back and forth easily after desoldering completely, pickup the corner of the IC using a tweezers and remove the IC by moving with the IC desoldering machine. (Refer to Fig. 2-3.)

#### NOTE

Some ICs on the PCB are affixed with glue, so be careful not to break or damage the foil of each IC leads or solder lands under the IC when removing it.

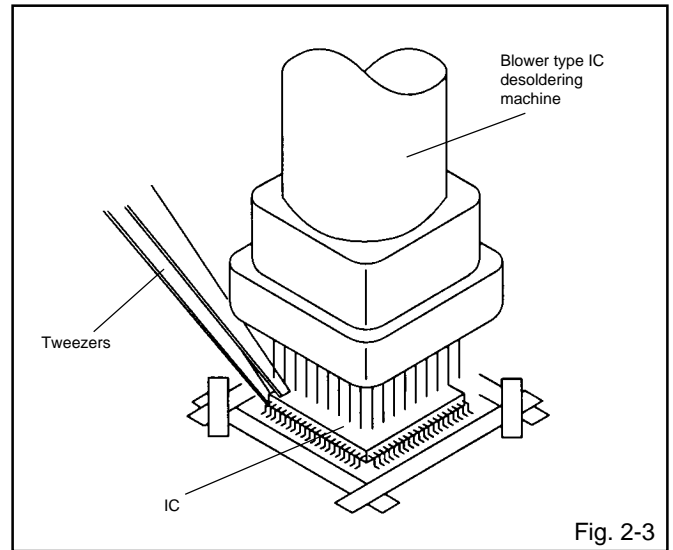

4. Peel off the Masking Tape.

5. Absorb the solder left on the pattern using the Braided Shield Wire. (Refer to Fig. 2-4.)

#### NOTE

Do not move the Braided Shield Wire in the vertical direction towards the IC pattern.

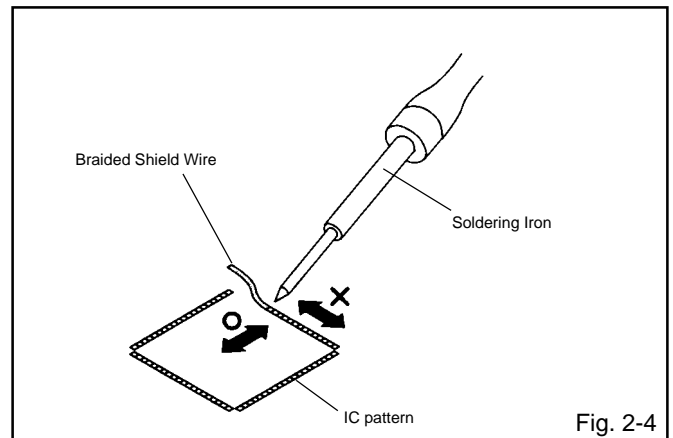

# DISASSEMBLY INSTRUCTIONS

## INSTALLATION

1. Take care of the polarity of new IC and then install the new IC fitting on the printed circuit pattern. Then solder each lead on the diagonal positions of IC temporarily. (Refer to Fig. 2-5.)

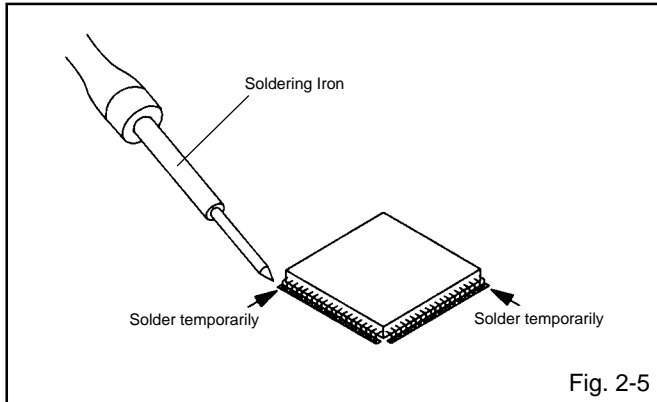

2. Supply the solder from the upper position of IC leads sliding to the lower position of the IC leads. (Refer to Fig. 2-6.)

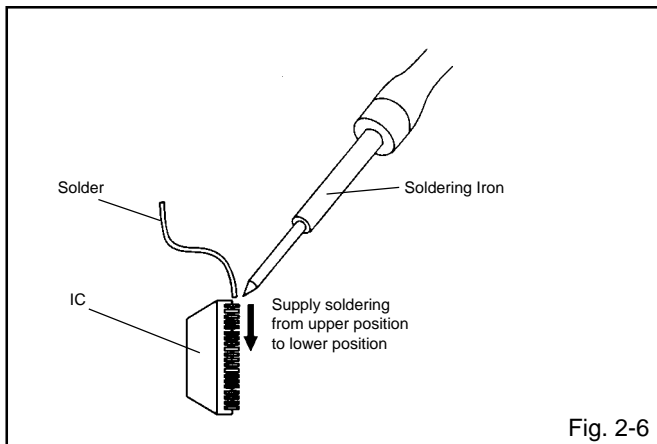

3. Absorb the solder left on the lead using the Braided Shield Wire. (Refer to Fig. 2-7.)

### NOTE

Do not absorb the solder to excess.

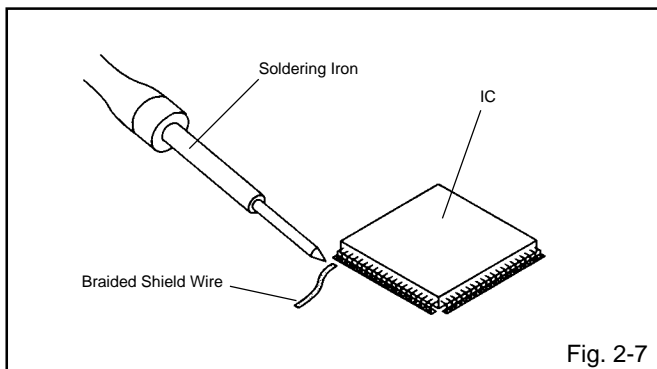

4. When bridge-soldering between terminals and/or the soldering amount are not enough, resolder using a Thin-tip Soldering Iron. (Refer to Fig. 2-8.)

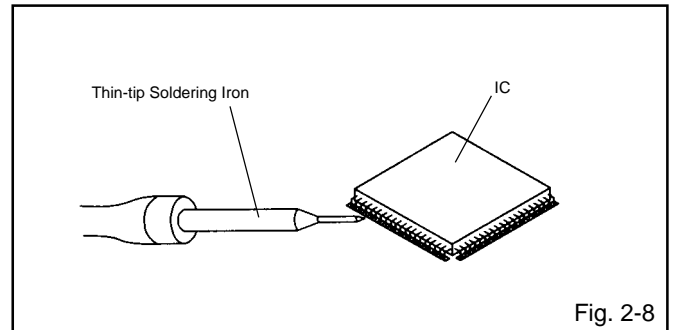

5. Finally, confirm the soldering status on four sides of the IC using a magnifying glass. Confirm that no abnormality is found on the soldering position and installation position of the parts around the IC. If some abnormality is found, correct by resoldering.

### NOTE

When the IC leads are bent during soldering and/or repairing, do not repair the bending of leads. If the bending of leads are repaired, the pattern may be damaged. So, always be sure to replace the IC in this case.

## SERVICE MODE LIST

This unit provided with the following SERVICE MODES so you can repair, examine and adjust easily. To enter the Service Mode, press both set key and remote control key for more than 1 second.

Set Key	Remocon Key	Operations
VOL. (-) MIN	0	Releasing of V-CHIP PASSWORD.
VOL. (-) MIN	1	Initialization of the factory. NOTE: Do not use this for the normal servicing. If you set a factory initialization, the memories are reset such as the channel setting, and the POWER ON total hours.
VOL. (-) MIN	6	POWER ON total hours is displayed on the screen. Refer to the "CONFIRMATION OF HOURS USED".  Can be checked of the INITIAL DATA of MEMORY IC. Refer to the "WHEN REPLACING EEPROM (MEMORY) IC".
VOL. (-) MIN	8	Writing of EEPROM initial data. NOTE: Do not use this for the normal servicing.
VOL. (-) MIN	9	Display of the Adjustment MENU on the screen. Refer to the "ELECTRICAL ADJUSTMENT" (On-Screen Display Adjustment).

### CONFIRMATION OF HOURS USED

POWER ON total hours can be checked on the screen. Total hours are displayed in 16 system of notation.

**NOTE: If you set a factory initialization, the total hours is reset to "0".**

1. Set the VOLUME to minimum.
2. Press both VOL. DOWN button on the set and Channel button (6) on the remote control for more than 1 second.
3. After the confirmation of using hours, turn off the power.

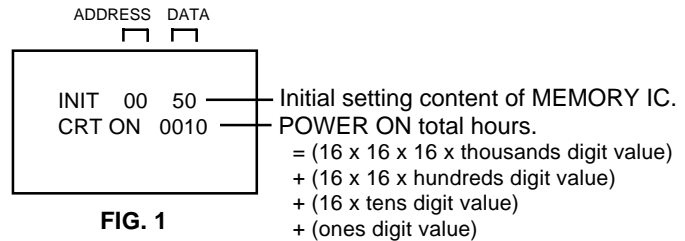

### WHEN REPLACING EEPROM (MEMORY) IC

If a service repair is undertaken where it has been required to change the MEMORY IC, the following steps should be taken to ensure correct data settings while making reference to TABLE 1.

**NOTE: No need setting for after INI 1F due to the adjustment value.**

INI	+0	+1	+2	+3	+4	+5	+6	+7	+8	+9	+A	+B	+C	+D	+E	+F
00	50	E8	0A	65	5E	B3	24	B7	39	AC	0A	04	40	40	40	7F
10	50	00	00	00	00	00	00	00	28	0F	0D	E2	A6	88	42	00

**Table 1**

1. Enter DATA SET mode by setting VOLUME to minimum.
  2. Press both VOL. DOWN button on the set and Channel button (6) on the remote control for more than 1 second. ADDRESS and DATA should appear as FIG 1.
  3. ADDRESS is now selected and should "blink". Using the VOL. UP/DOWN button on the remote, step through the ADDRESS until required ADDRESS to be changed is reached.
  4. Press ENTER to select DATA. When DATA is selected, it will "blink".
  5. Again, step through the DATA using VOL. UP/DOWN button until required DATA value has been selected.
  6. Pressing ENTER will take you back to ADDRESS for further selection if necessary.
  7. Repeat steps 3 to 6 until all data has been checked.
  8. When satisfied correct DATA has been entered, turn POWER off (return to STANDBY MODE) to finish DATA input.  
**After the data input, set to the initializing of shipping.**
  9. Turn POWER on.
  10. Press both VOL. DOWN button on the set and Channel button (1) on the remote control for more than 1 second.
  11. After the finishing of the initializing of shipping, the unit will turn off automatically.
- The unit will now have the correct DATA for the new MEMORY IC.

# ELECTRICAL ADJUSTMENTS

## 1. BEFORE MAKING ELECTRICAL ADJUSTMENTS

Read and perform these adjustments when repairing the circuits or replacing electrical parts or PCB assemblies.

### CAUTION

- Use an isolation transformer when performing any service on this chassis.
- Before removing the anode cap, discharge electricity because it contains high voltage.
- When removing a PCB or related component, after unfastening or changing a wire, be sure to put the wire back in its original position.
- When you exchange IC and Transistor for a heat sink, apply the silicon grease on the contact section of the heat sink. Before applying new silicon grease, remove all the old silicon grease. (Old grease may cause damages to the IC and Transistor.)

Prepare the following measurement tools for electrical adjustments.

1. Oscilloscope
2. Digital Voltmeter
3. Multi-sound Generator
4. Pattern Generator

### On-Screen Display Adjustment

1. In the condition of NO indication on the screen. Press the VOL. DOWN button on the set and the Channel button (9) on the remote control for more than 1 second to appear the adjustment mode on the screen as shown in Fig. 1-1.

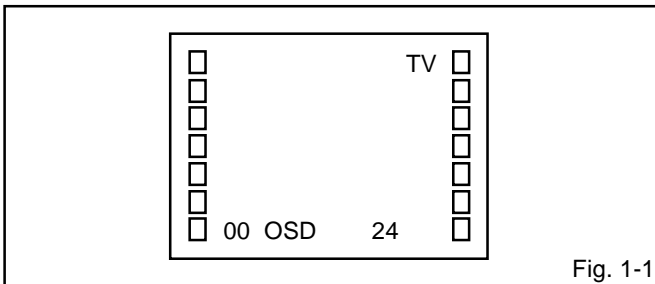

Fig. 1-1

2. Use the Channel UP/DOWN button or Channel button (0-9) on the remote control to select the options shown in Fig. 1-2.
3. Press the MENU button on the remote control to end the adjustments.

NO.	FUNCTION	NO.	FUNCTION	NO.	FUNCTION
00	OSD H	13	G CUT OFF	26	CB DELAY FINE
01	CUT OFF	14	B CUT OFF	27	CR DELAY FINE
02	H.VCO	15	BRIGHT MAX	28	CB PEDESTAL ADJ
03	H.PHASE	16	BRIGHT CENT	29	CR PEDESTAL ADJ
04	AFC GAIN	17	BRIGHT MIN	30	E/W PARABOLA
05	V.SHIFT	18	CONTRAST MAX	31	E/W CORNER
06	H.SIZE	19	CONTRAST CENT	32	E/W TRAPEZIUM
07	V.SIZE	20	CONTRAST MIN	33	LEVEL
08	V.LINEARITY	21	COLOR MAX	34	SEPARATION 1
09	VS CORRECTION	22	COLOR CENT	35	SEPARATION 2
10	DRIVE R	23	COLOR MIN		
11	DRIVE B	24	TINT		
12	R CUT OFF	25	SHARPNESS		

Fig. 1-2

## 2. BASIC ADJUSTMENTS

### 2-1: CONSTANT VOLTAGE

1. Place the set with Aging Test for more than 5 minutes.
2. Set condition is AV MODE without signal.
3. Using the remote control, set the brightness and contrast to normal position.
4. Connect the digital voltmeter to the TP003.
5. Adjust the VR502 until the digital voltmeter is  $115 \pm 1V$ .

### 2-2: CUT OFF

1. Place the set with Aging Test for more than 15 minutes.
2. Activate the adjustment mode display of Fig. 1-1 and press the channel button (01) on the remote control to select "CUT OFF".
3. Adjust the Screen Volume until a dim raster is obtained.

### 2-3: WHITE BALANCE

NOTE: Adjust after performing CUT OFF adjustment.

1. Place the set with Aging Test for more than 10 minutes.
2. Receive the gray scale pattern from the Pattern Generator.
3. Using the remote control, set the brightness and contrast to normal position.
4. Activate the adjustment mode display of Fig. 1-1 and press the channel button (10) on the remote control to select "R. DRIVE".
5. Press the CH. UP/DOWN button on the remote control to select the "R. BIAS", "G. BIAS", "B. BIAS", "R. DRIVE" or "B. DRIVE".
6. Adjust the VOL. UP/DOWN button on the remote control to whiten the R. BIAS, G. BIAS, B. BIAS, R. DRIVE, and B. DRIVE at each step tone sections equally.
7. Perform the above adjustments 5 and 6 until the white color is looked like a white.

### 2-4: FOCUS

1. Receive a broadcast.
2. Turn the Focus Volume fully counterclockwise once.
3. Adjust the Focus Volume until picture is distinct.

### 2-5: HORIZONTAL PHASE

1. Receive the monoscope pattern.
2. Using the remote control, set the brightness and contrast to normal position.
3. Activate the adjustment mode display of Fig. 1-1 and press the channel button (03) on the remote control to select "H.PHAS".
4. Press the VOL. UP/DOWN button on the remote control until the SHIFT quantity of the OVER SCAN on right and left becomes minimum.

### 2-6: VERTICAL POSITION

1. Receive the monoscope pattern.
2. Using the remote control, set the brightness and contrast to normal position.
3. Adjust the VR401 until the horizontal line becomes fit to the notch of the shadow mask.

# ELECTRICAL ADJUSTMENTS

## 2-7: VERTICAL SIZE

1. Receive the monoscope pattern.
2. Using the remote control, set the brightness and contrast to normal position.
3. Activate the adjustment mode display of **Fig. 1-1** and press the channel button **(07)** on the remote control to select "V.SIZE".
4. Press the VOL. UP/DOWN button on the remote control until the SHIFT quantity of the OVER SCAN on upside and downside becomes  $9 \pm 2\%$ .
5. Receive a broadcast and check if the picture is normal.

## 2-8: VERTICAL LINEARITY

**NOTE:** Adjust after performing adjustments in section 2-7. After the adjustment of Vertical Linearity, reconfirm the Vertical Position and Vertical Size adjustments.

1. Receive the monoscope pattern.
2. Using the remote control, set the brightness and contrast to normal position.
3. Activate the adjustment mode display of **Fig. 1-1** and press the channel button **(08)** on the remote control to select "V.LIN".
4. Press the VOL. UP/DOWN button on the remote control until the SHIFT quantity of the OVER SCAN on upside and downside becomes minimum.

## 2-9: BRIGHT CENT

1. Receive the monoscope pattern. (RF Input)
2. Using the remote control, set the brightness and contrast to normal position.
3. Activate the adjustment mode display of **Fig. 1-1** and press the channel button **(16)** on the remote control to select "BRI CENT".
4. Press the VOL. UP/DOWN button on the remote control until the white 0% is starting to be visible
5. Receive the monoscope pattern. (Audio Video Input)
6. Press the TV/VIDEO button on the remote control to set to the AV mode. Then perform the above adjustments 2~4.
7. Press the TV/VIDEO button on the remote control to set to the CS mode.
8. Activate the adjustment mode display of **Fig. 1-1** and press the channel button **(16)** on the remote control to select "BRI CENT".
9. Press the VOL. UP/DOWN button on the remote control until the contrast step No. becomes "77".
10. Receive a broadcast and check if the picture is normal.

## 2-10: TINT/COLOR CENT

1. Receive the color bar pattern. (RF Input)
2. Connect the oscilloscope to **TP024**.
3. Using the remote control, set the brightness, contrast, color and tint to normal position.
4. Activate the adjustment mode display of **Fig. 1-1** and press the channel button **(24)** on the remote control to select "TINT".
5. Press the VOL. UP/DOWN button on the remote control until the section "A" becomes a straight line **(Refer to Fig. 2-1)**.
6. Connect the oscilloscope to **TP023**.
7. Press the CH DOWN button 2 times to set to "COL. CENT" mode.
8. Adjust the VOLTS RANGE VARIABLE knob of the oscilloscope until the range between white 100% and 0% is set to 5 scales on the screen of the oscilloscope.
9. Press the VOL. UP/DOWN button on the remote control until the red color level is adjusted to  $115 \pm 10\%$  of the white level. **(Refer to Fig. 2-2)**
10. Receive the color bar pattern. (Audio Video Input)
11. Press the TV/VIDEO button on the remote control to set to the AV mode. Then perform the above adjustments 2~9.
12. Press the TV/VIDEO button on the remote control to set to the CS mode.
13. Activate the adjustment mode display of **Fig. 1-1** and press the channel button **(24)** on the remote control to select "TINT".
14. Press the VOL. UP/DOWN button on the remote control until the contrast step No. becomes "55".
15. Press the CH DOWN button 2 times to set to "COL.CENT" mode.
16. Press the VOL. UP/DOWN button on the remote control until the contrast step No. becomes "50".
17. Receive a broadcast and check if the picture is normal.

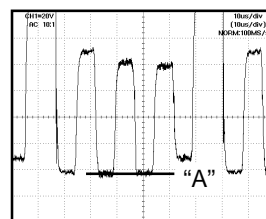

Fig. 2-1

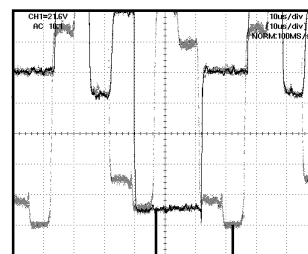

Fig. 2-2

# ELECTRICAL ADJUSTMENTS

## 2-11: CONTRAST MAX MANUAL

1. Activate the adjustment mode display of **Fig. 1-1** and press the channel button **(18)** on the remote control to select "CONT.MAX".
2. Press the VOL. UP/DOWN button on the remote control until the contrast step No. becomes "74".
3. Receive a broadcast and check if the picture is normal.
4. Press the TV/VIDEO button on the remote to set to the AV mode.
5. Activate the adjustment mode display of **Fig. 1-1** and press the channel button **(18)** on the remote control to select "CONT.MAX".
6. Press the VOL. UP/DOWN button on the remote control until the contrast step No. becomes "86".
7. Receive a broadcast and check if the picture is normal.
8. Press the TV/VIDEO button on the remote to set to the CS mode.
9. Activate the adjustment mode display of **Fig. 1-1** and press the channel button **(18)** on the remote control to select "CONT.MAX".
10. Press the VOL. UP/DOWN button on the remote control until the contrast step No. becomes "90".
11. Receive a broadcast and check if the picture is normal.

## 2-12: SEPARATION 1, 2

Please do the method (1) or method (2) adjustment.

### Method (1)

1. Set the multi-sound signal generator for each different L-ch and R-ch frequency (Ex. L-ch=2KHz, R-ch=400Hz) and receive the RF.
2. Connect the oscilloscope to the **Audio Out Jack**.
3. Activate the adjustment mode display of **Fig. 1-1** and press the channel button **(34)** on the remote control to select "SEP 1".
4. Press the VOL. UP/DOWN button on the remote control to adjust it until the audio output wave becomes a fine sine wave.
5. Press the CH UP button once the set to "SEP 2" mode. Then perform the above adjustment 4.

### Method (2)

1. Set the multi-sound signal generator L-ch=1KHz, R-ch=Non input and receive the RF.
2. Connect the oscilloscope to the **Audio Out Jack (R-ch)**.
3. Press the AUDIO SELECT button on the remote control to set to the stereo mode.
4. Activate the adjustment mode display of **Fig. 1-1** and press the channel button **(34)** on the remote control to select "SEP 1".
5. Press the VOL. UP/DOWN button on the remote control to adjust it until the R-ch output becomes minimum.
6. Set the multi-sound signal generator L-ch=Non input, R-ch=1KHz and receive the RF.
7. Connect the oscilloscope to the **Audio Out Jack (L-ch)**.
8. Activate the adjustment mode display of **Fig. 1-1** and press the channel button **(35)** on the remote control to select "SEP 2".
9. Press the VOL. UP/DOWN button on the remote control to adjust it until the L-ch output becomes minimum.

## 2-13: LEVEL

1. Receive the monoscope pattern (70dB).
2. Connect the AC voltmeter to **pin 6 of CP101**.
3. Activate the adjustment mode display of **Fig. 1-1** and press the channel button **(33)** on the remote control to select "LEVEL".
4. Press the VOL. UP/DOWN button on the remote control until the AC voltmeter is  $75 \pm 2\text{mV}$ .

## 2-14: OSD HORIZONTAL

1. Activate the adjustment mode display of **Fig. 1-1**.
2. Press the VOL. UP/DOWN button on the remote control until the difference of A and B becomes minimum. (**Refer to Fig. 2-3**)

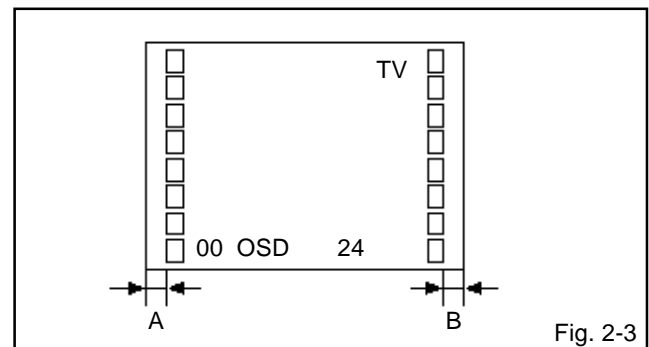

Fig. 2-3

## 2-15: Confirmation of Fixed Value (step No.)

Please check if the fixed values of the each adjustment items are set correctly referring below.

NO.	FUNCTION	STEP NO.
02	H.VCO	03
04	AFC GAIN	04
05	V.SHIFT	00
06	H.SIZE	00
09	VS CORRECTION	39
15	BRIGHT MAX	125
17	BRIGHT MIN	50
19	CONTRAST CENT	50
20	CONTRAST MIN	18
21	COLOR MAX	90
23	COLOR MIN	00
25	SHARPNESS	40
26	CB DELAY FINE	00
27	CR DELAY FINE	00
30	E/W PARABOLA	31
31	E/W CORNER	31
32	E/W TRAPEZIUM	31

# ELECTRICAL ADJUSTMENTS

## 3. PURITY AND CONVERGENCE ADJUSTMENTS

### NOTE

1. Turn the unit on and let it warm up for at least 30 minutes before performing the following adjustments.
2. Place the CRT surface facing east or west to reduce the terrestrial magnetism.
3. Turn ON the unit and demagnetize with a Degauss Coil.

### 3-1: STATIC CONVERGENCE (ROUGH ADJUSTMENT)

1. Tighten the screw for the magnet. Refer to the adjusted CRT for the position. **(Refer to Fig. 3-1)**  
If the deflection yoke and magnet are in one body, untighten the screw for the body.
2. Receive the green raster pattern from the color bar generator.
3. Slide the deflection yoke until it touches the funnel side of the CRT.
4. Adjust center of screen to green, with red and blue on the sides, using the pair of purity magnets.
5. Switch the color bar generator from the green raster pattern to the crosshatch pattern.
6. Combine red and blue of the 3 color crosshatch pattern on the center of the screen by adjusting the pair of 4 pole magnets.
7. Combine red/blue (magenta) and green by adjusting the pair of 6 pole magnets.
8. Adjust the crosshatch pattern to change to white by repeating steps 6 and 7.

### 3-2: PURITY

#### NOTE

Adjust after performing adjustments in section 3-1.

1. Receive the green raster pattern from color bar generator.
2. Adjust the pair of purity magnets to center the color on the screen.  
Adjust the pair of purity magnets so the color at the ends are equally wide.
3. Move the deflection yoke backward (to neck side) slowly, and stop it at the position when the whole screen is green.
4. Confirm red and blue color.
5. Adjust the slant of the deflection yoke while watching the screen, then tighten the fixing screw.

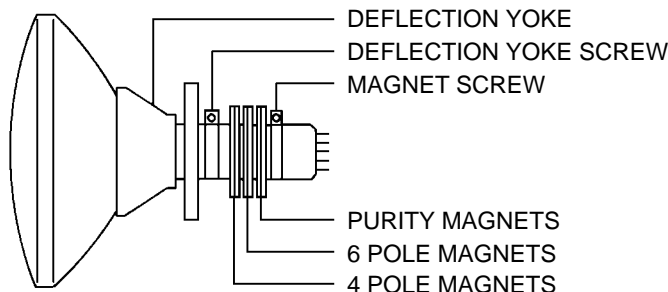

Fig. 3-1

### 3-3: STATIC CONVERGENCE

#### NOTE

Adjust after performing adjustments in section 3-2.

1. Receive the crosshatch pattern from the color bar generator.
2. Combine red and blue of the 3 color crosshatch pattern on the center of the screen by adjusting the pair of 4 pole magnets.
3. Combine red/blue (magenta) and green by adjusting the pair of 6 pole magnets.

### 3-4: DYNAMIC CONVERGENCE

#### NOTE

Adjust after performing adjustments in section 3-3.

1. Adjust the differences around the screen by moving the deflection yoke upward/downward and right/left. **(Refer to Fig. 3-2-a)**
2. Insert three wedges between the deflection yoke and CRT funnel to fix the deflection yoke. **(Refer to Fig. 3-2-b)**

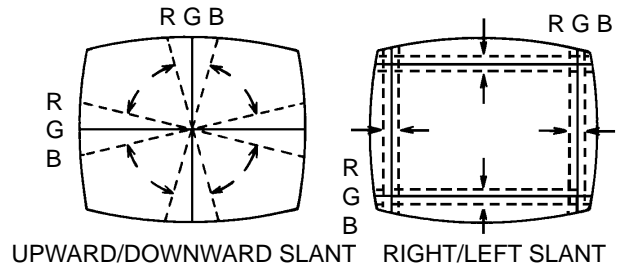
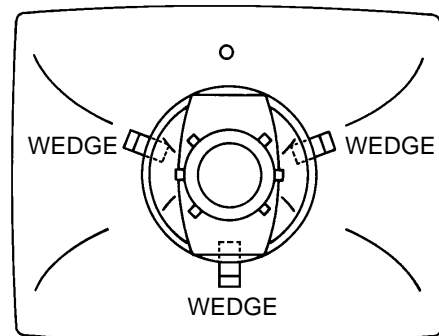

Fig. 3-2-a



WEDGE POSITION

Fig. 3-2-b

# ELECTRICAL ADJUSTMENTS

## 4. ELECTRICAL ADJUSTMENT PARTS LOCATION GUIDE (WIRING CONNECTION)

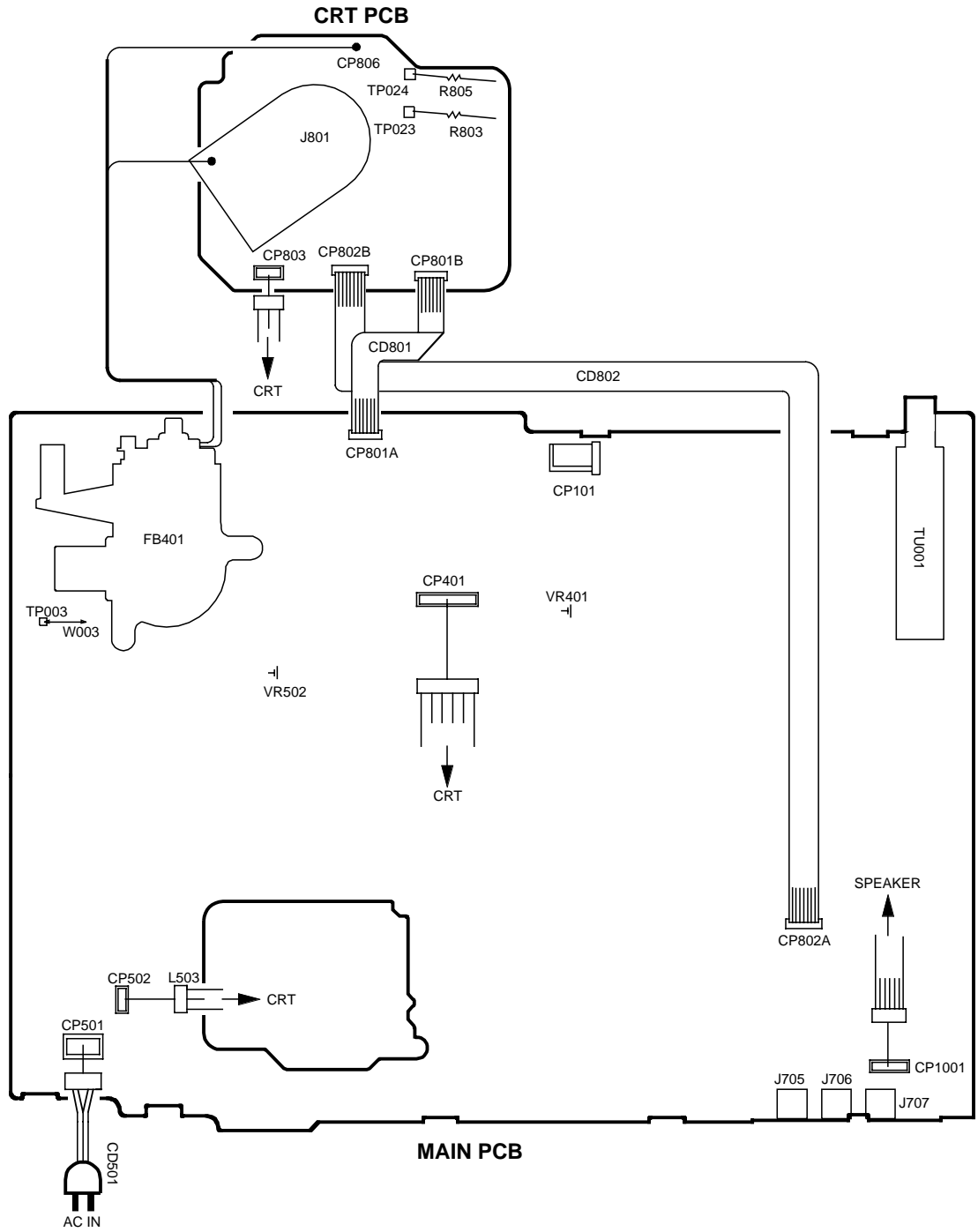

### BLOCK DIAGRAM

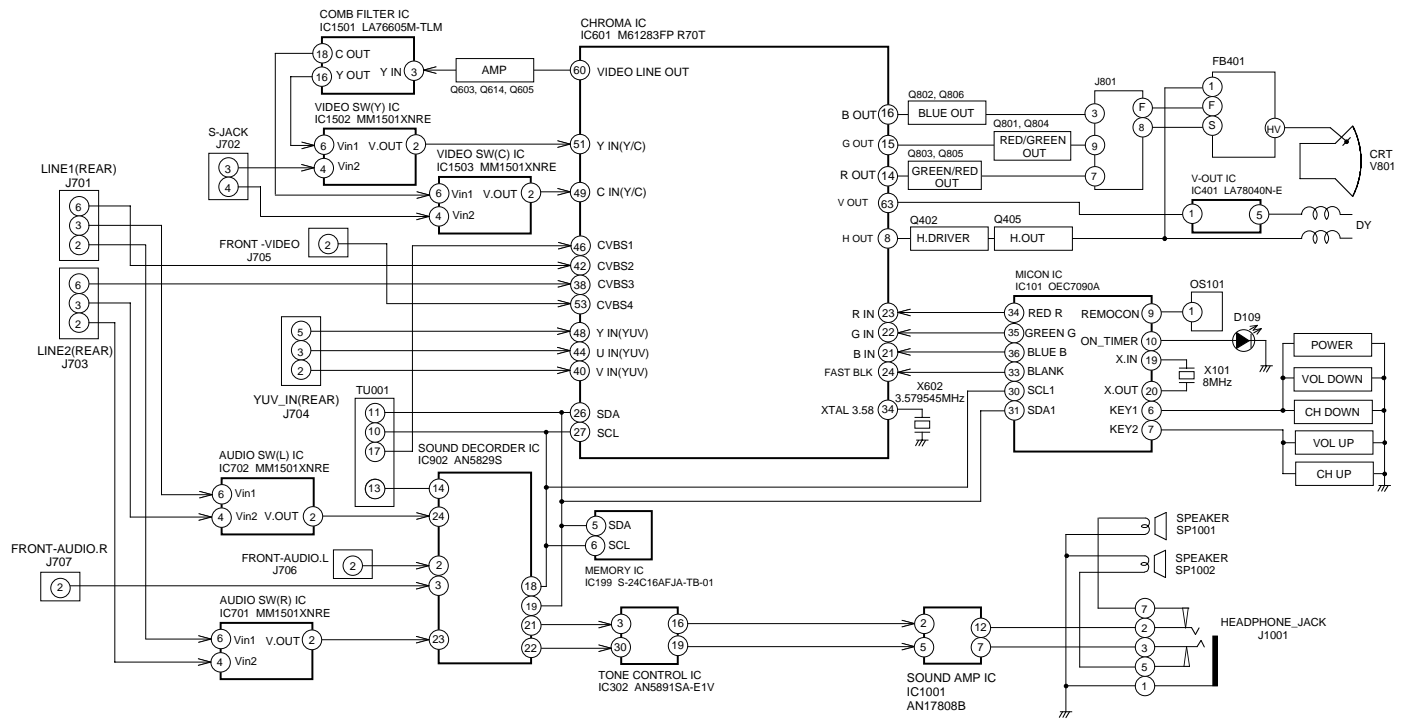

PRINTED CIRCUIT BOARDS  
MAIN/CRT (INSERTED PARTS)  
SOLDER SIDE

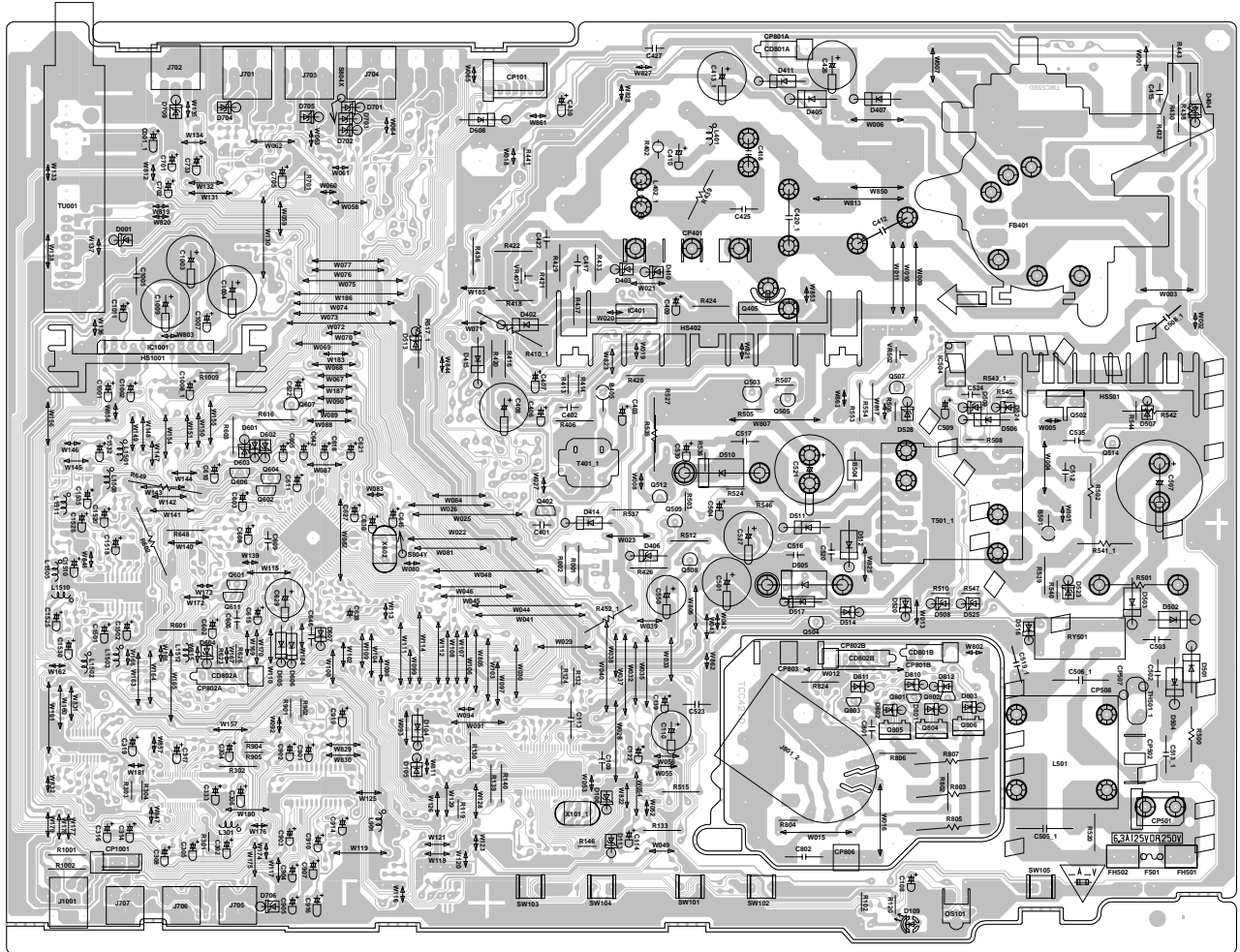



# MICON SCHEMATIC DIAGRAM (MAIN PCB)

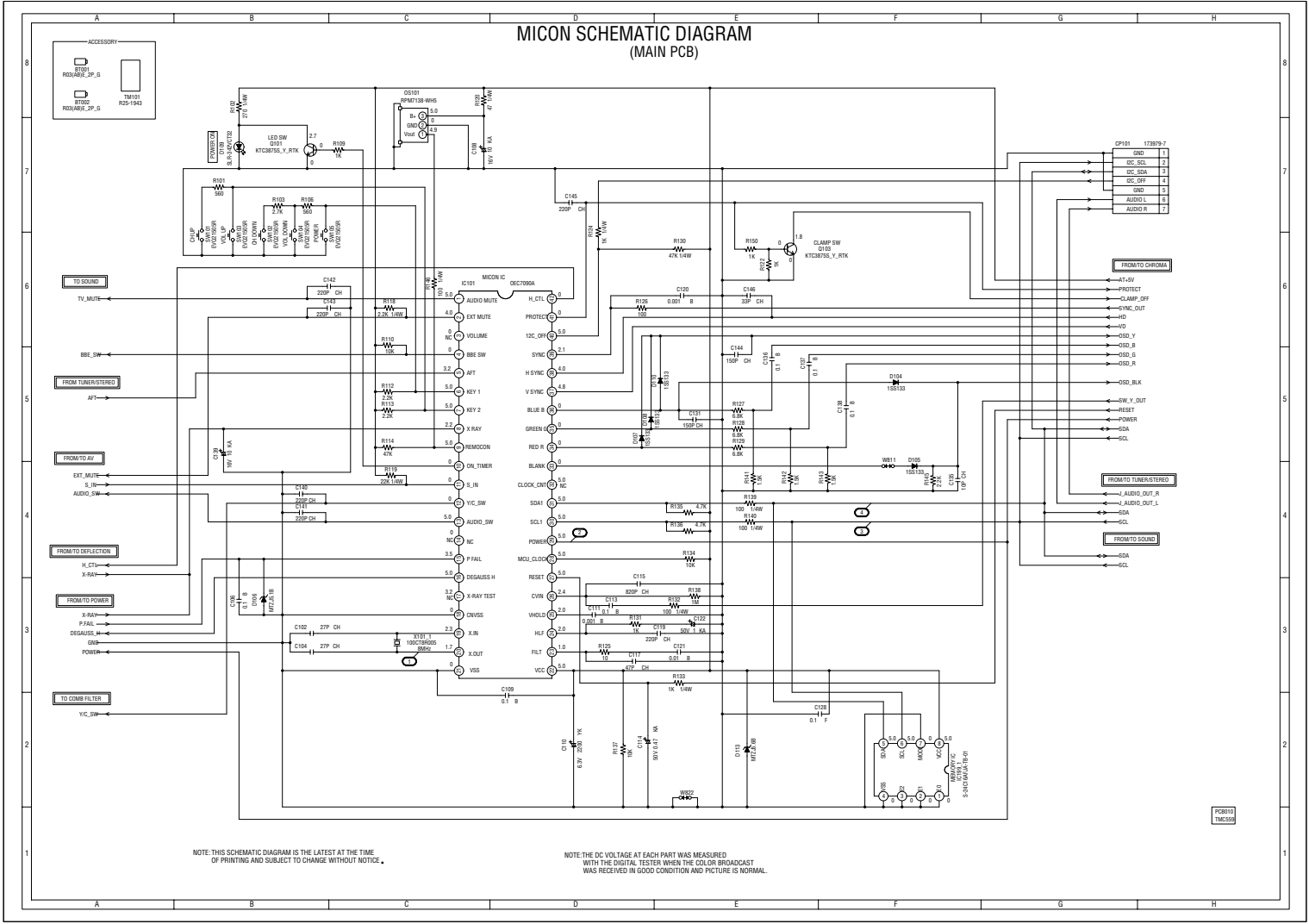

NOTE: THIS SCHEMATIC DIAGRAM IS THE LATEST AT THE TIME OF PRINTING AND SUBJECT TO CHANGE WITHOUT NOTICE.

NOTE: THE DC VOLTAGE AT EACH PART WAS MEASURED WITH THE DIGITAL TESTER WHEN THE COLOR BROADCAST WAS RECEIVED IN GOOD CONDITION AND PICTURE IS NORMAL.

FR810  
ENC100

# CHROMA SCHEMATIC DIAGRAM (MAIN PCB)

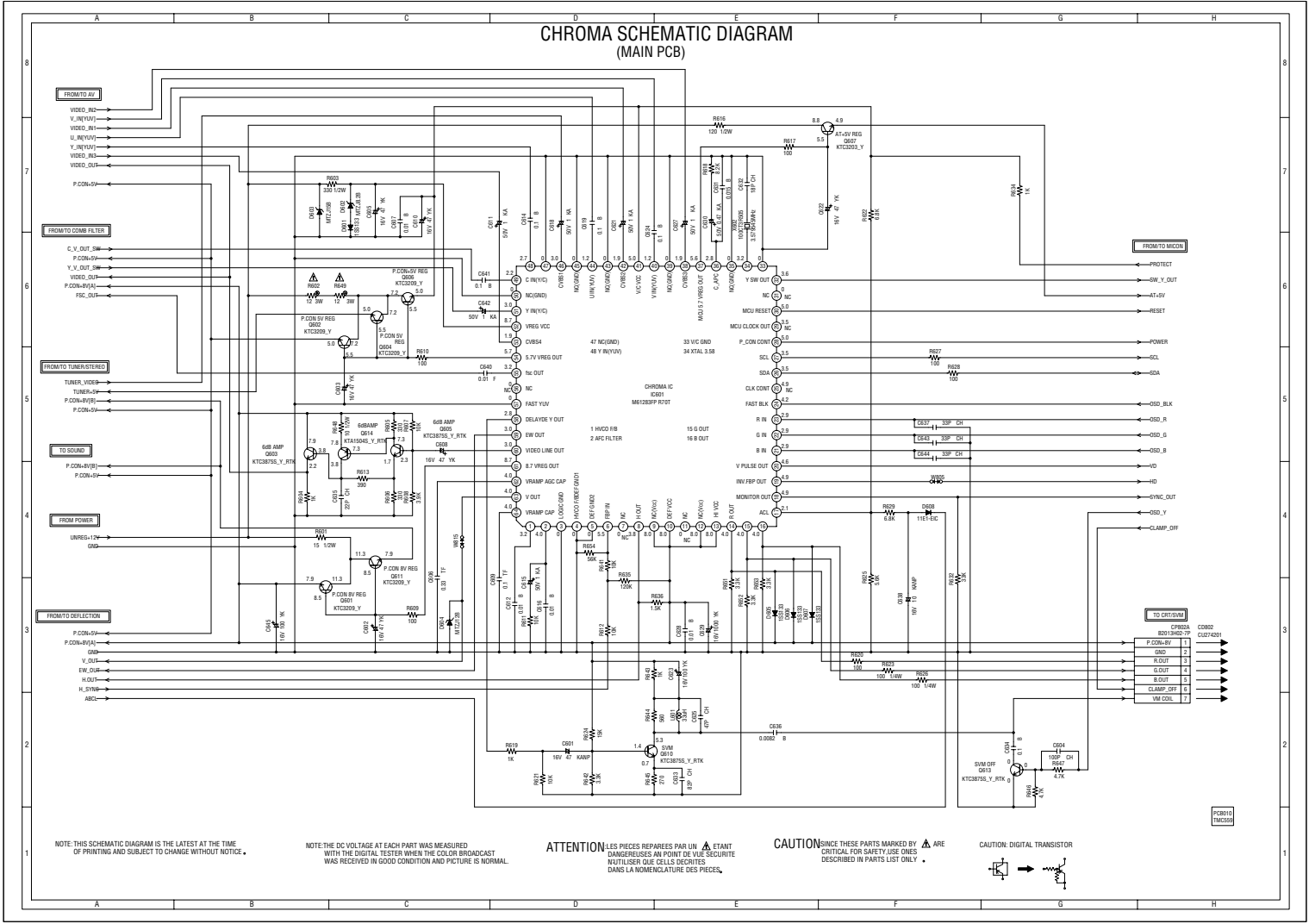

NOTE: THIS SCHEMATIC DIAGRAM IS THE LATEST AT THE TIME OF PRINTING AND SUBJECT TO CHANGE WITHOUT NOTICE.

NOTE: THE DC VOLTAGE AT EACH PART WAS MEASURED WITH THE DIGITAL TESTER WHEN THE COLOR BROADCAST WAS RECEIVED IN GOOD CONDITION AND PICTURE IS NORMAL.

**ATTENTION** LES PIÈCES RÉPARÉES PAR UN ÉTANT DANGEREUSES À UN POINT DE VUE SÉCURITÉ, UTILISER DES CELLES SÉCURITÉES DANS LA NOMENCLATURE DES PIÈCES.

**CAUTION** SINCE THESE PARTS MARKED BY ARE CRITICAL FOR SAFETY USE ONES DESCRIBED IN PARTS LIST ONLY.

CAUTION: DIGITAL TRANSISTOR

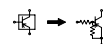

PC8010  
1M0200

## DEFLECTION SCHEMATIC DIAGRAM (MAIN PCB)

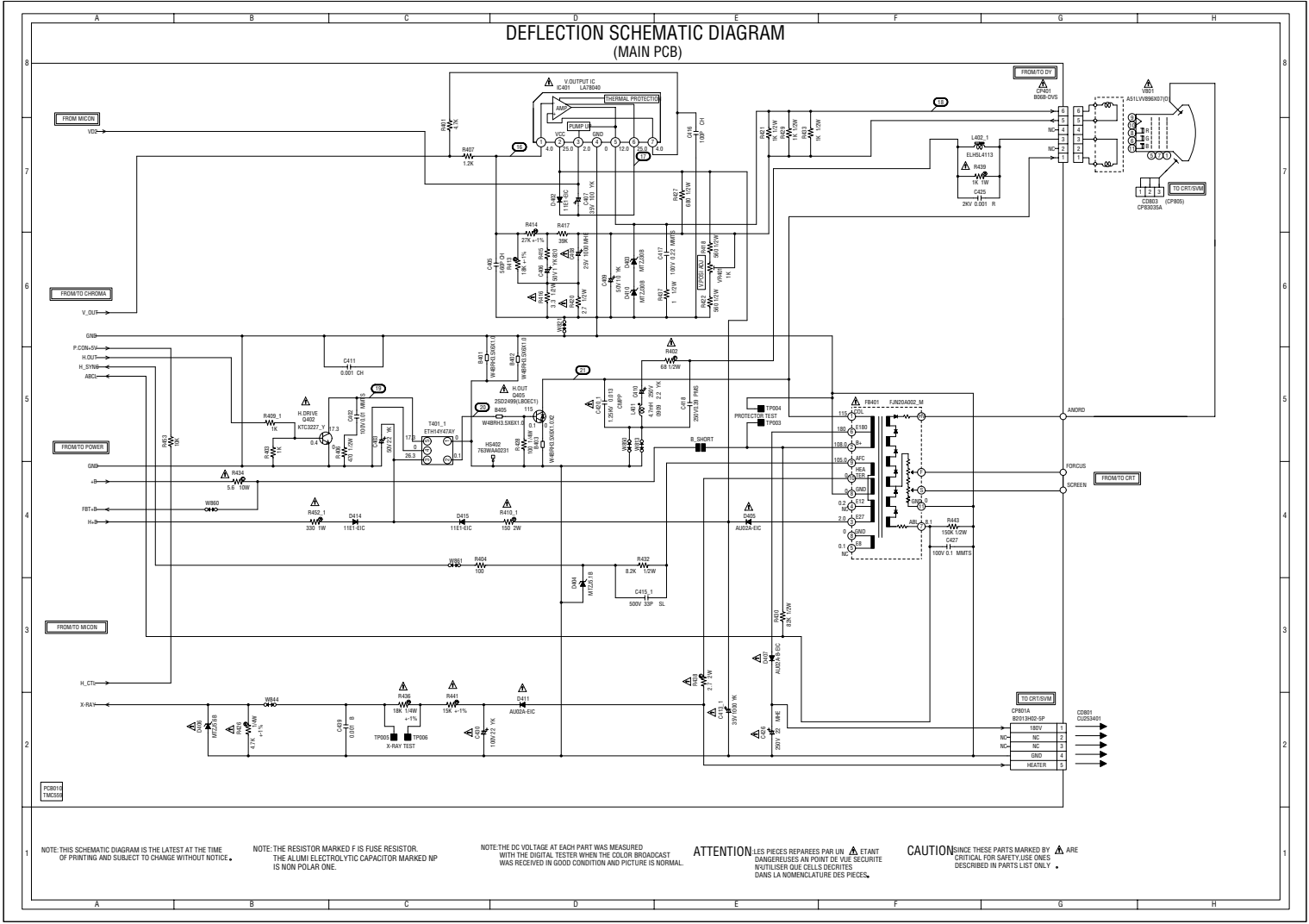

# POWER SCHEMATIC DIAGRAM (MAIN PCB)

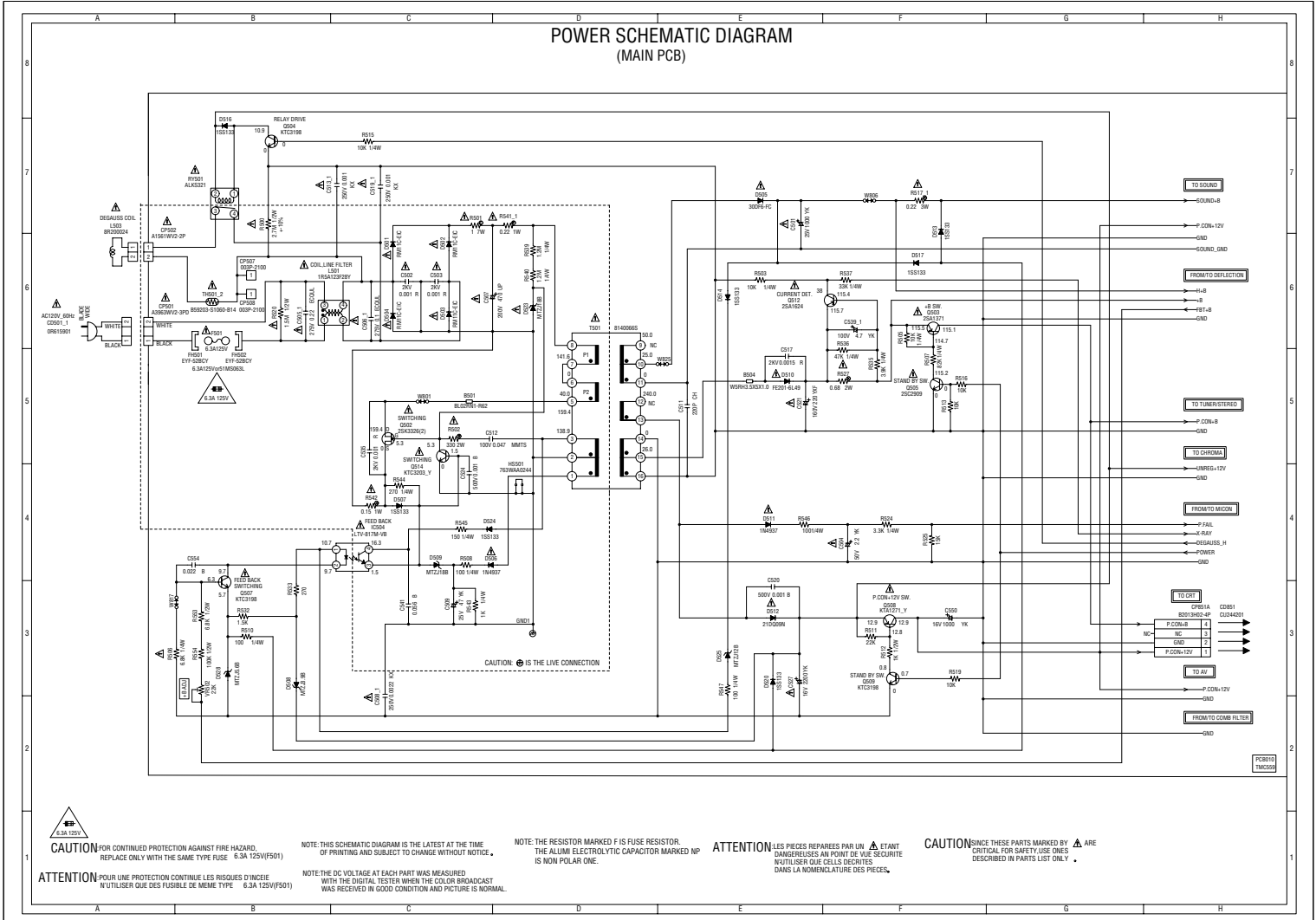

**CAUTION** FOR CONTINUED PROTECTION AGAINST FIRE HAZARD,  
REPLACE ONLY WITH THE SAME TYPE FUSE 6.3A 125V(F501)

**ATTENTION** POUR UNE PROTECTION CONTINUE LES RISQUES D'INCENDIE  
N'UTILISER QUE DES FUSIBLES DE MEME TYPE 6.3A 125V(F501)

NOTE: THIS SCHEMATIC DIAGRAM IS THE LATEST AT THE TIME  
OF PRINTING AND SUBJECT TO CHANGE WITHOUT NOTICE.

NOTE: THE DC VOLTAGE AT EACH PART WAS MEASURED  
WITH THE DIGITAL TESTER WHEN THE COLOR BROADCAST  
WAS RECEIVED IN GOOD CONDITION AND PICTURE IS NORMAL.

NOTE: THE RESISTOR MARKED F IS FUSE RESISTOR.  
THE ALUMI ELECTROLYTIC CAPACITOR MARKED NP  
IS NON POLAR ONE.

**ATTENTION** LES PIÈCES REPARABLES PAR UN  
D'ÉTANT DANGEREUSES AU POINT DE VUE SECURITE  
N'UTILISER QUE CELLES DECRITES  
DANS LA NOMENCLATURE DES PIÈCES.

**CAUTION** SINCE THESE PARTS MARKED BY ARE  
CRITICAL FOR SAFETY, USE ONES  
DESCRIBED IN PARTS LIST ONLY.

F501  
TMC05

# SOUND SCHEMATIC DIAGRAM (MAIN PCB)

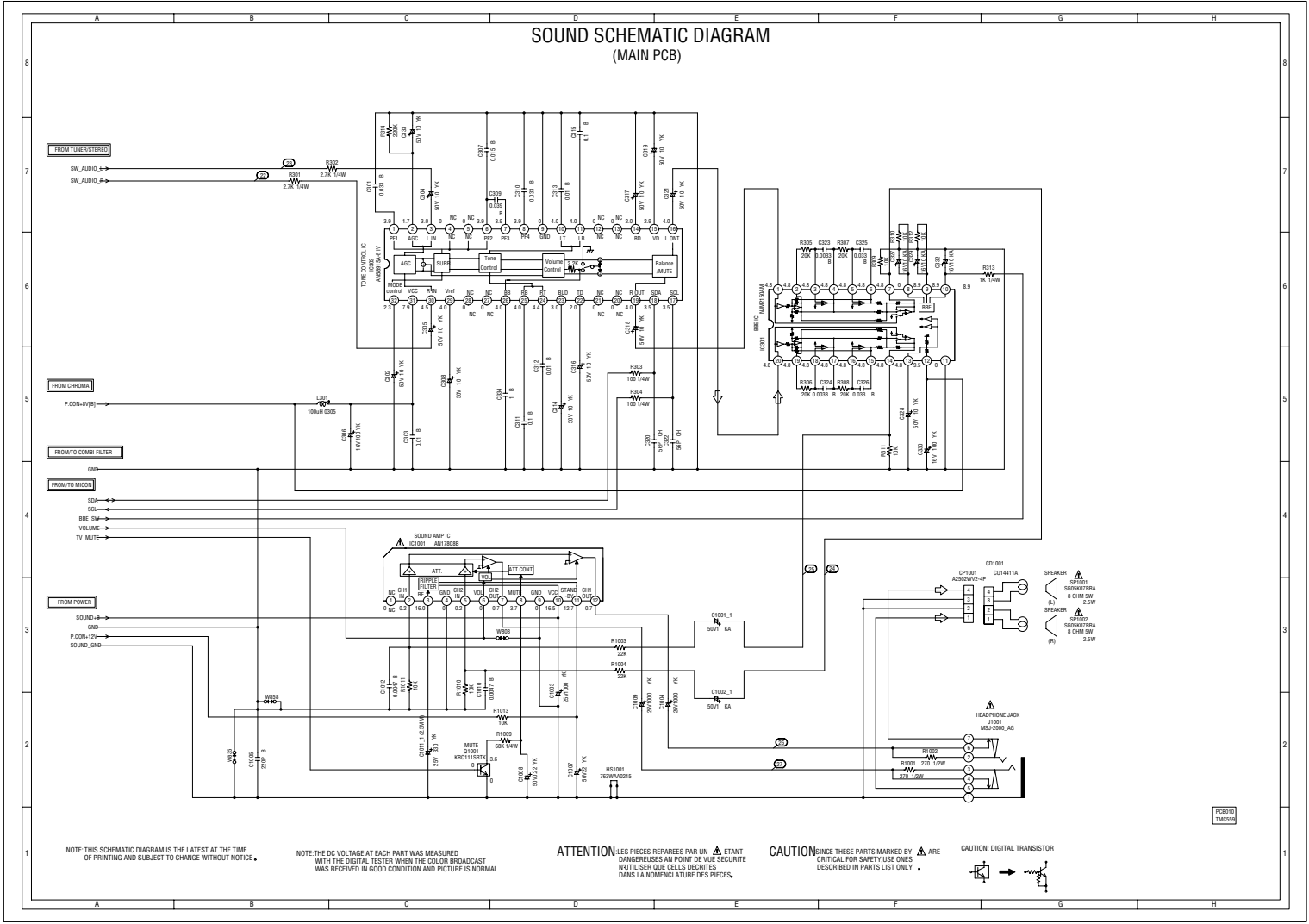

NOTE: THIS SCHEMATIC DIAGRAM IS THE LATEST AT THE TIME OF PRINTING AND SUBJECT TO CHANGE WITHOUT NOTICE.

NOTE: THE DC VOLTAGE AT EACH PART WAS MEASURED WITH THE DIGITAL TESTER WHEN THE COLOR BROADCAST WAS RECEIVED IN GOOD CONDITION AND PICTURE IS NORMAL.

**ATTENTION** LES PIÈCES REPAREES PAR UN ETANT DANGEREUSES AN POINT DE VUE SECURITE UTILISER QUE CELLES DECRITES DANS LA NOMENCLATURE DES PIÈCES.

**CAUTION** THESE PARTS MARKED BY ARE CRITICAL FOR SAFETY. USE ONES DESCRIBED IN PARTS LIST ONLY.

CAUTION: DIGITAL TRANSISTOR

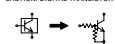
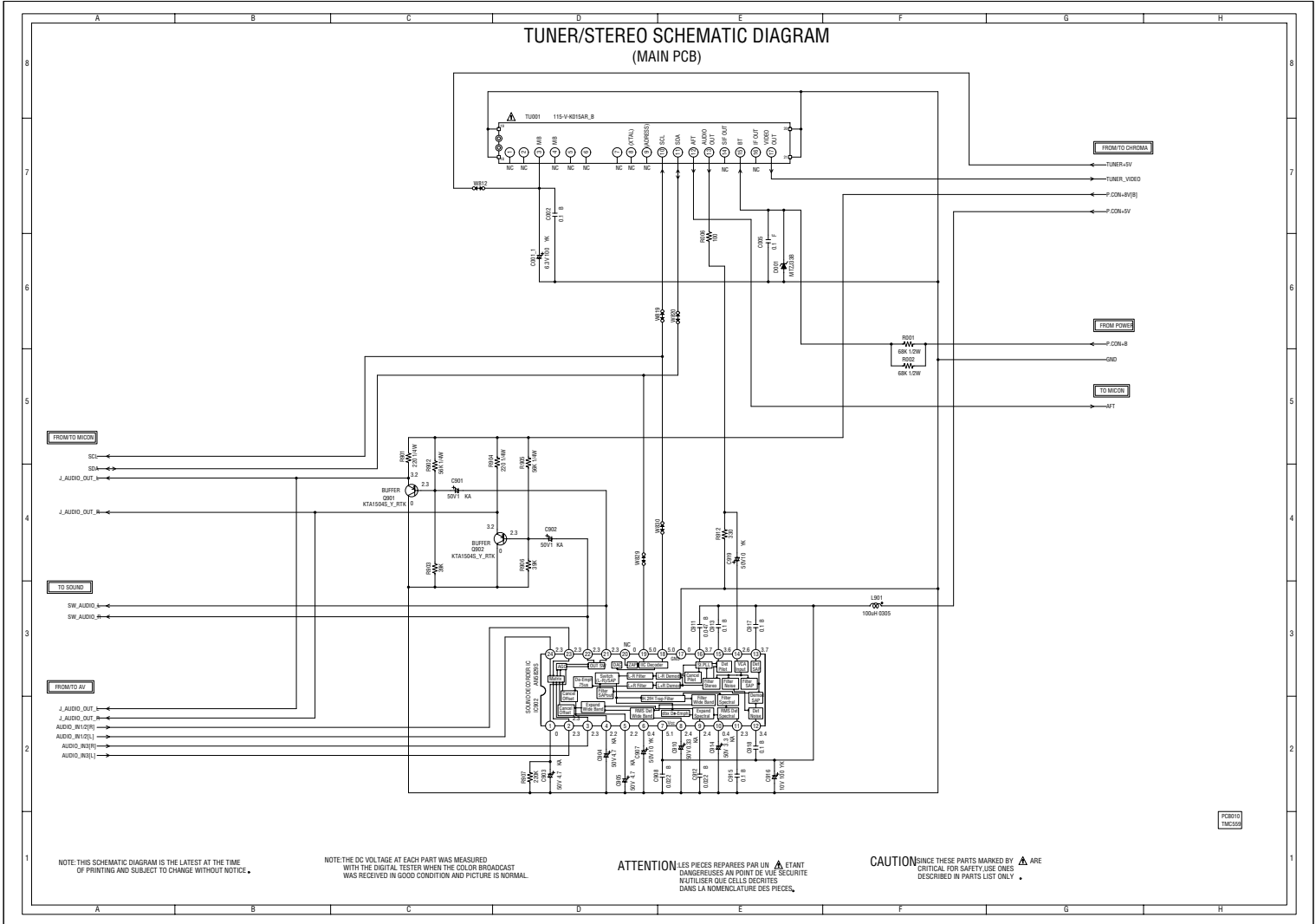

FIG.101  
TMS2001

## TUNER/STEREO SCHEMATIC DIAGRAM (MAIN PCB)



NOTE: THIS SCHEMATIC DIAGRAM IS THE LATEST AT THE TIME OF PRINTING AND SUBJECT TO CHANGE WITHOUT NOTICE.

NOTE: THE DC VOLTAGE AT EACH PART WAS MEASURED WITH THE DIGITAL TESTER WHEN THE COLOR BROADCAST WAS RECEIVED IN GOOD CONDITION AND PICTURE IS NORMAL.

**ATTENTION** LES PIÈCES RÉPARÉES PAR UN ETANT DANGEREUSES AU POINT DE VUE SÉCURITÉ, UTILISER QUE CELLES SÉCURITÉ DANS LA NOMÉCLATURE DES PIÈCES.

**CAUTION** SINCE THESE PARTS MARKED BY ARE CRITICAL FOR SAFETY, USE ONES DESCRIBED IN PARTS LIST ONLY.

FR010  
TMC550

# AV SCHEMATIC DIAGRAM (MAIN PCB)

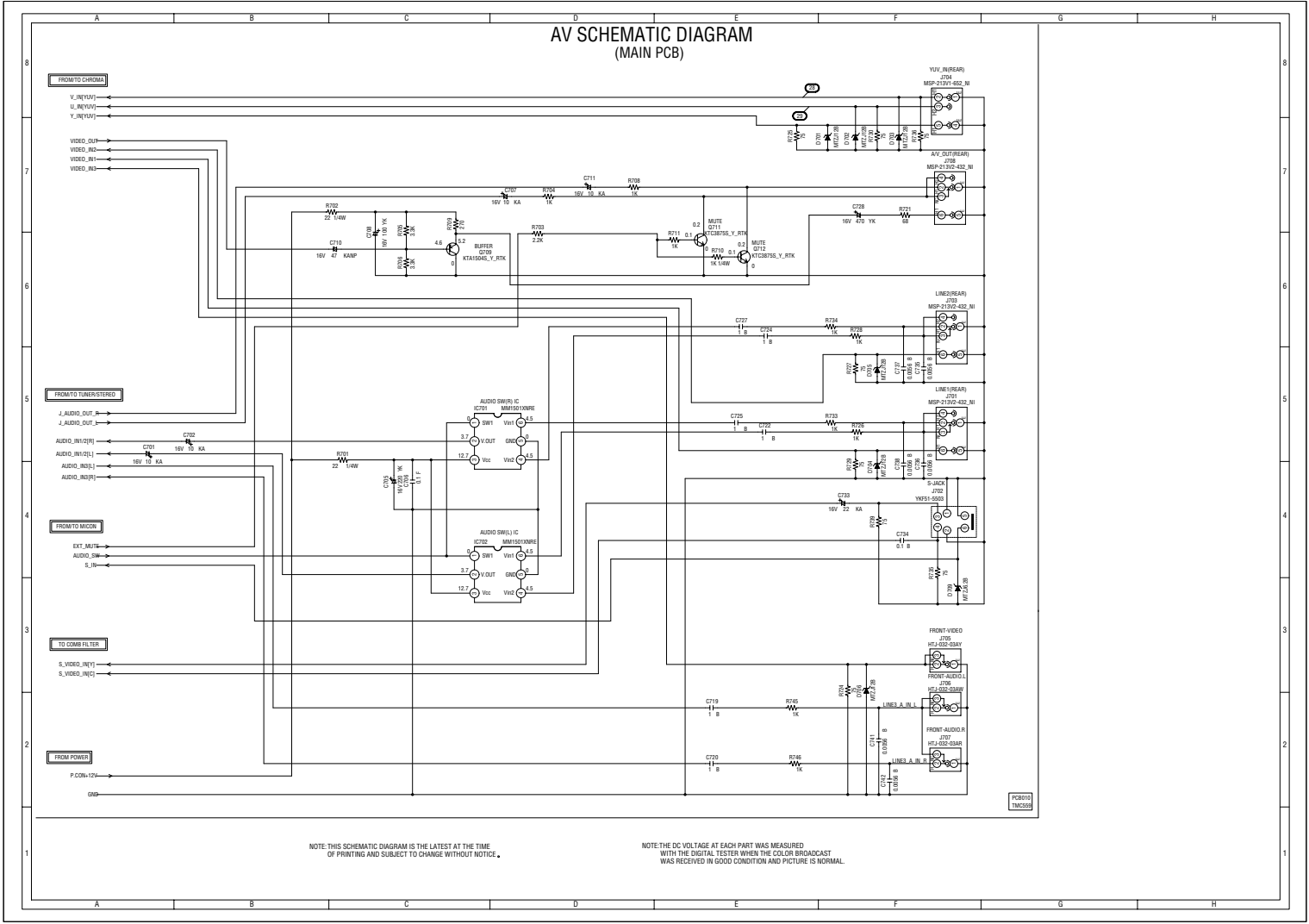





# WAVEFORMS

## MICON

## SOUND

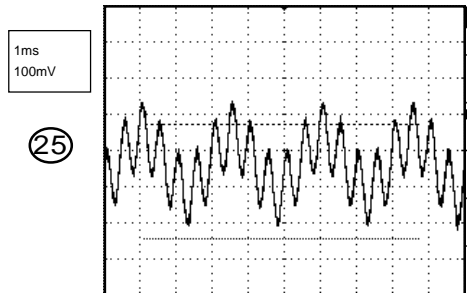
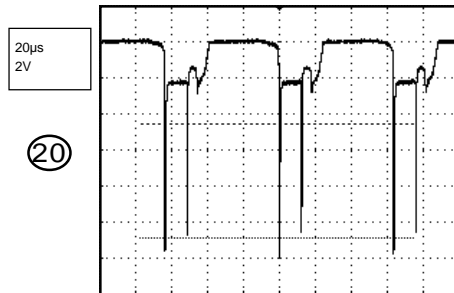
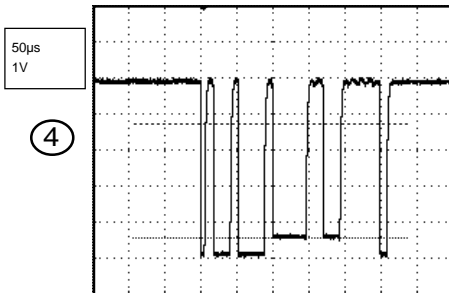
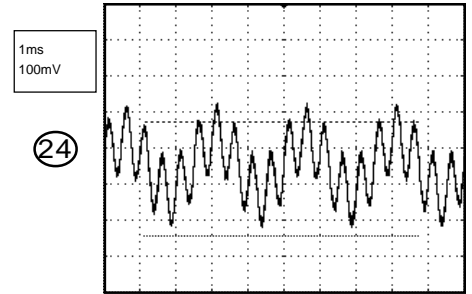
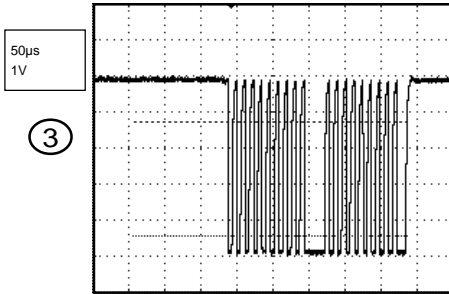
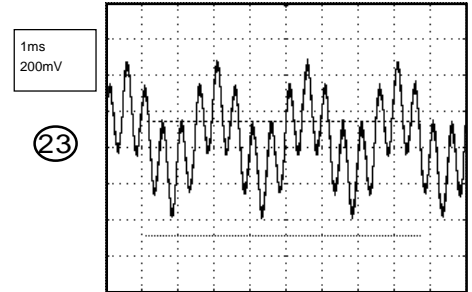
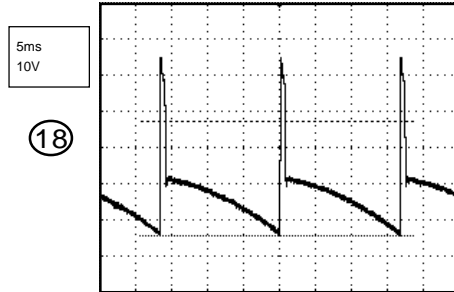
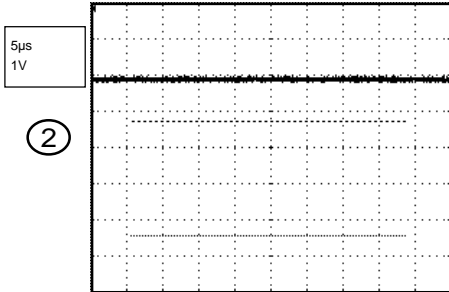
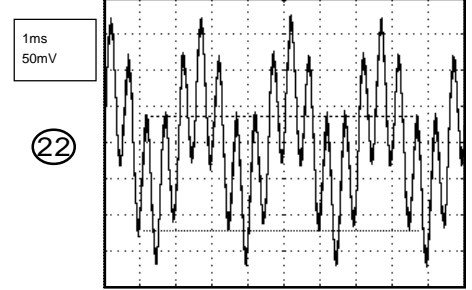
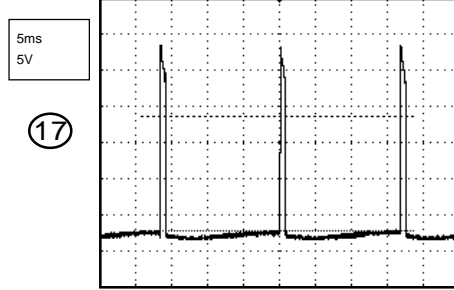
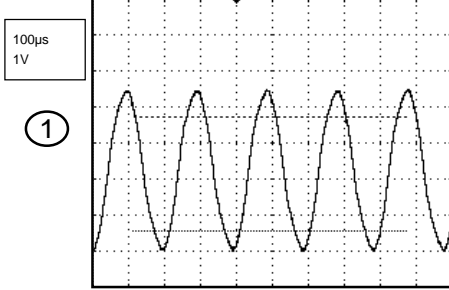

## DEFLECTION

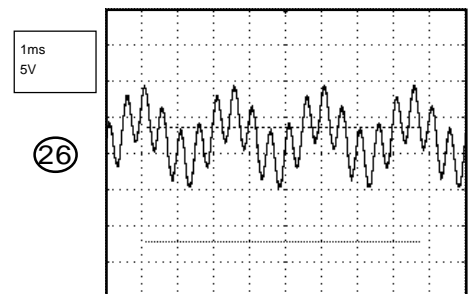
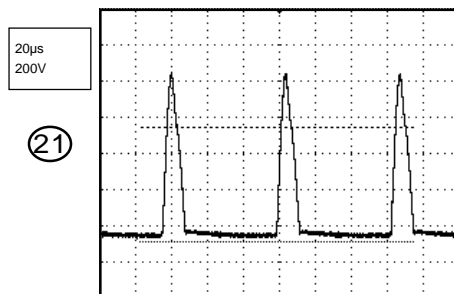
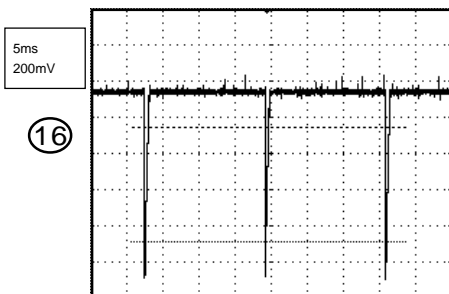

NOTE: The following waveforms were measured at the point of the corresponding balloon number in the schematic diagram.

# WAVEFORMS

1ms  
5V

27

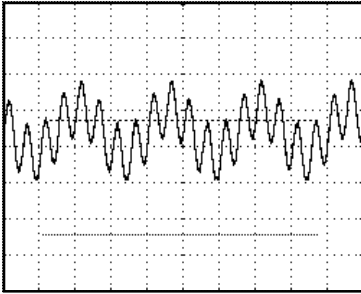

20μs  
50V

39

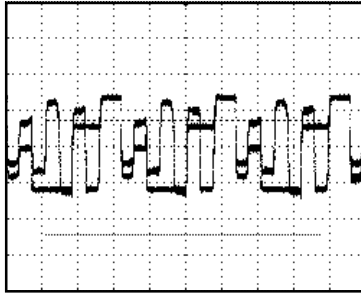

## AV

20μs  
200mV

28

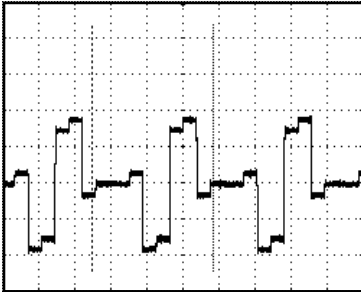

20μs  
200mV

29

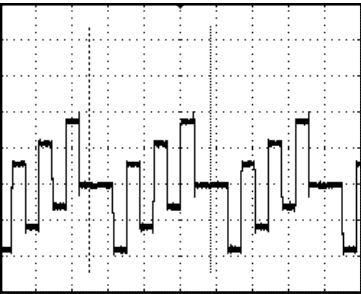

## CRT

20μs  
50V

37



20μs  
50V

38

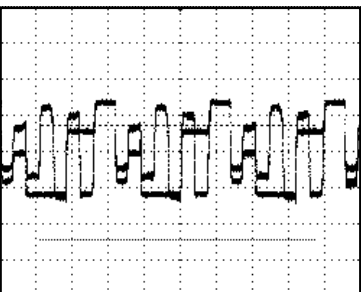

NOTE: The following waveforms were measured at the point of the corresponding balloon number in the schematic diagram.

# MECHANICAL EXPLODED VIEW

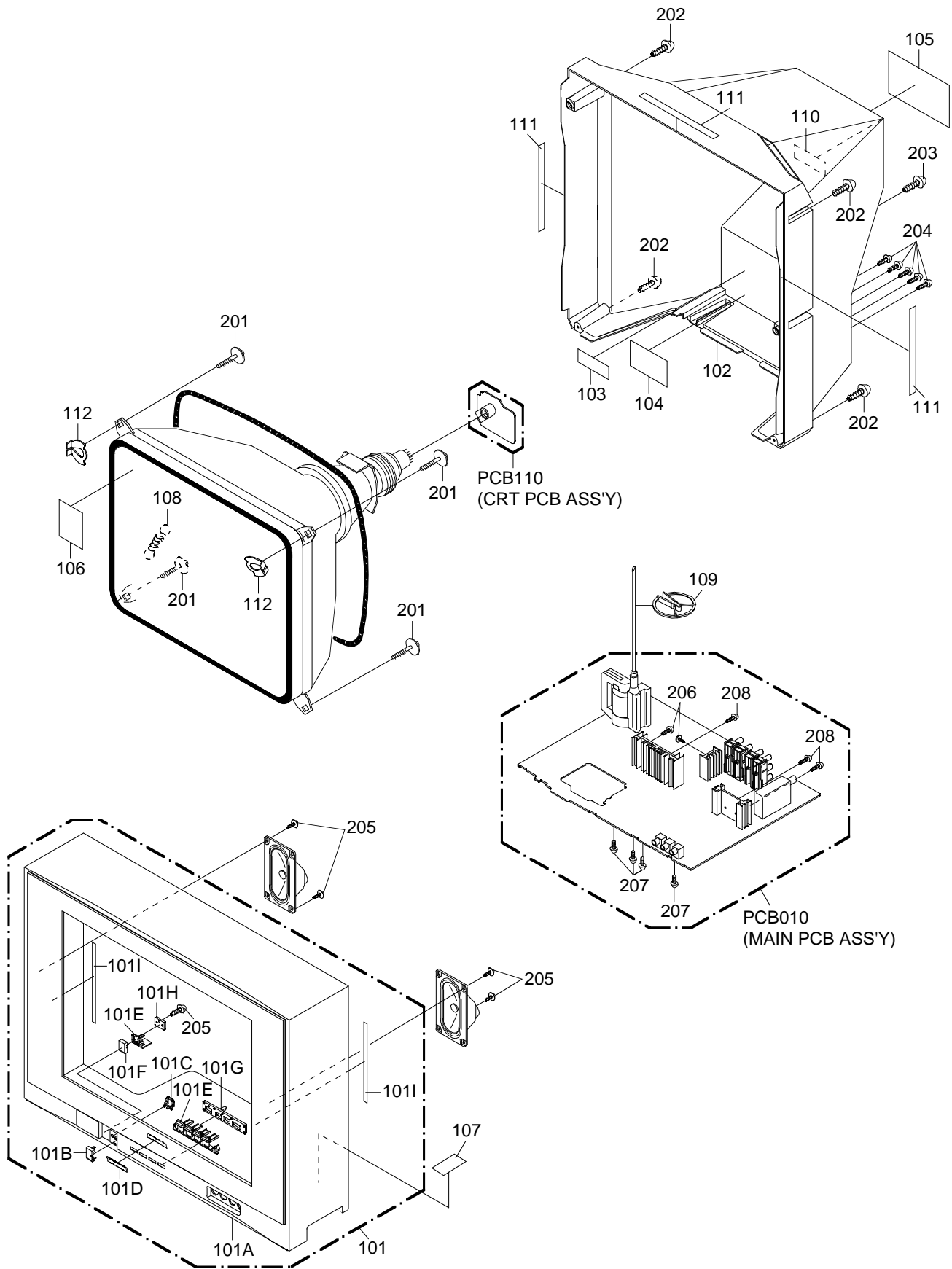

# MECHANICAL EXPLODED VIEW (PACKING DIAGRAM)

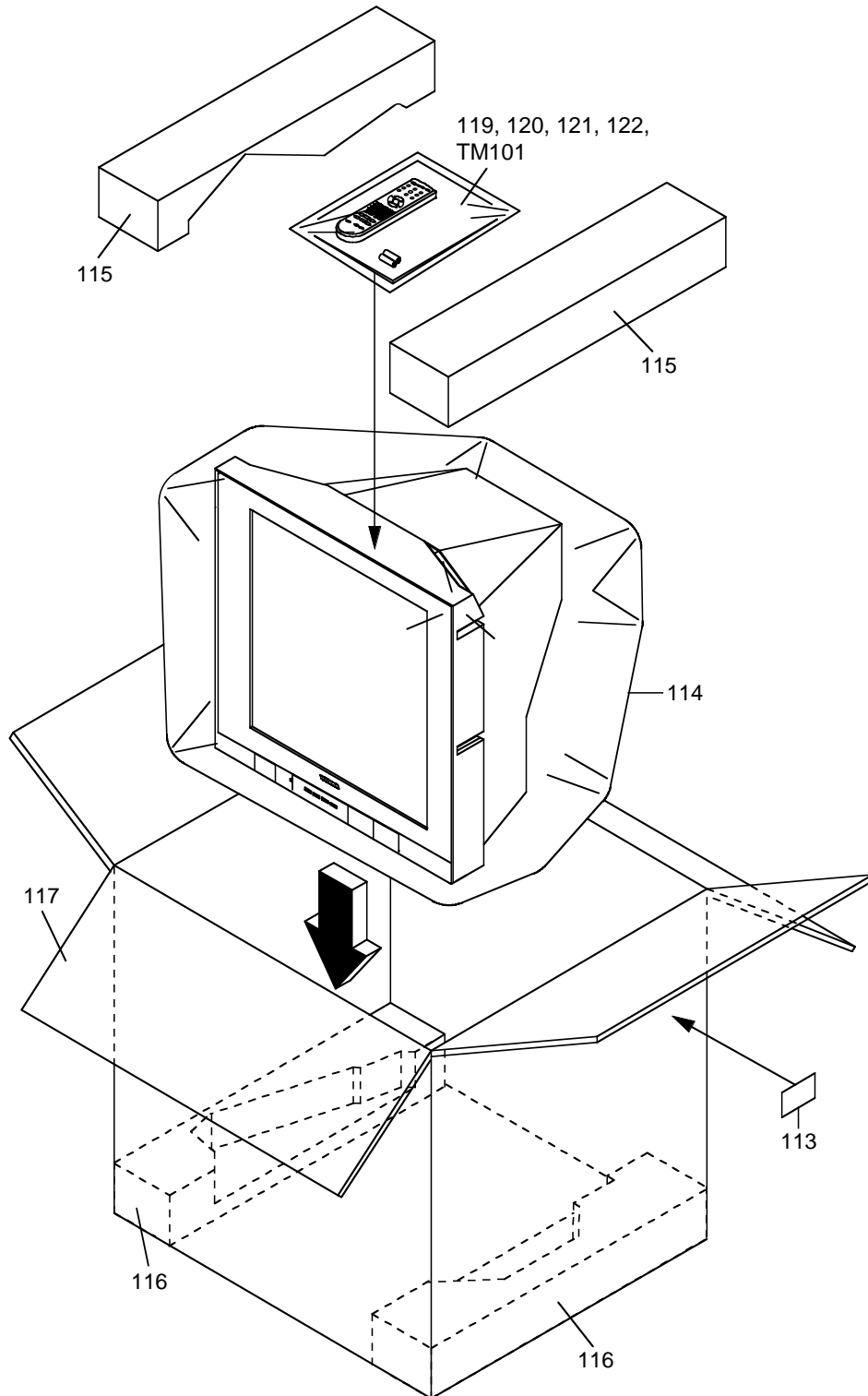

# MECHANICAL REPLACEMENT PARTS LIST

Location No.	TSB P/N	Reference No.	Description	
101	AE003148	7A701A063A	FRONT CABI ASS'Y	
101A	AE003149	701WPJC559	CABINET,FRONT	
101B	AD302279	711WPA0187	PLATE,FRONT	
101C	AD302280	713WPA0274	GLASS,LED	
101D	AE000539	723549A016	BADGE,BRAND	
101E	AE003150	735WPBA996	BUTTON,FRAME	
101F	AE003151	735WPJA820	BUTTON,POWER	
101G	AD302009	735WPA0728	STOPPER,BUTTON 1	
101H	AD302283	735WPA0748	STOPPER,BUTTON 2	
101I	AE000174	800WQ00056	FELT SHEET	
102	AE003152	A3M813J740	CABINET,BACK ASSY	
103	AE000091	722000A023	SHEET,HWC	
104	AE000006	7220001119	SHEET,CSA WARNING	
105	AE003153	722549A331	SHEET,RATING	
106	AE004050	723000C263	POP LABEL	
107	AD300132	7230006818	SHEET,CAUTION	
108	AD300759	741WUA0021	SPRING,EARTH	
109	BZ710260	899HV3T000	HOLDER,ANODE WIRE	
110	AE004051	726000A059	SHEET,CRT NO.	
111	AE003071	800WQ0A041	FELT SHEET	
112	AD300135	769WSA0011	WASHER CRT T=0.5	
113	AE003155	723000C501	SHEET,BAR CODE	
114	AE000093	791WHA0090	LAMIFILM,BAG	
115	AD302286	792WHA0446	PACKAGE, TOP	
116	AD302287	792WHA0447	PACKAGE,BOTTOM	
117	AE003156	793WCDC107	GIFT BOX	
118	AE004052	A3M813J975	INSTRUCTION BOOK KIT	
119	AD301213	JA4UD300	POLYBAG,INSTRUCTION(REDCAUTION)	
120	AD300022	J3I70417	REGISTRATION CARD	
121	AD300023	J3I70436	ESP CARD	
122	AE004053	J3M81301A	INSTRUCTION BOOK	
201	BZ710383	8121J50C04	SCREW,TAPPING(B0) GW15	5x30
202	BZ710035	8117540A64	SCREW,TAPPING(B0) TRUSS	4x16
203	BZ710262	8117540A04	SCREW,TAPPING(B0) TRUSS	4x10
204	BZ710031	8110630A04	SCREW,TAP TITE(P) BRAZIER	3x10
205	BZ710030	8110630804	SCREW,TAP TITE(P) BRAZIER	3x8
206	BZ710239	8109I30A04	SCREW,TAP TITE(B) WH7	3x10
207	BZ710019	8109630802	SCREW,TAP TITE(B) BRAZIER	3x8
208	BZ710018	8107630804	SCREW,TAP TITE(S) BRAZIER	3x8

# ELECTRICAL REPLACEMENT PARTS LIST

Location No.	TSB P/N	Reference No.	Description
<b>RESISTORS</b>			
△R402	BZ210041	R635U2680J	R,FUSE 68 OHM 1/2W
△R410	BZ210087	R3X18A221J	R,METAL OXIDE 220 OHM 2W
△R426	BZ210030	R4X5T4472F	R,METAL 4.7K OHM 1/4W
△R436	BZ210023	R4X5T4183F	R,METAL 18K OHM 1/4W
△R438	BZ210232	R6558A6R8J	R,FUSE 6.8 OHM 2W
△R439	AE000676	R3K181102J	R,METAL 1K OHM 1W
△R441	AD300037	R4X5T6153F	R,METAL 15K OHM 1/6W
△R452	AD301143	R3X181R27J	R,METAL OXIDE 0.27 OHM 1W
△R500	BZ210080	R0G3K2275K	RC 2.7M OHM 1/2W
△R501	AD301596	R5X2AE010J	R,CEMENT 1 OHM 7W
△R502	AD301016	R3X28A331J	R,METAL OXIDE 330 OHM 2W
△R506	BZ210162	R002T4682J	RC 6.8K OHM 1/4W
△R517	BZ210191	R3X28B010J	R,METAL 1 OHM 3W
△R520	BZ210206	R002T2155J	RC 1.5M OHM 1/2W
△R527	AD300042	R3X18A010J	R,METAL OXIDE 1 OHM 2W
△R541	BZ210190	R63581R22J	R,FUSE 0.22 OHM 1W
△R542	BZ210063	R3X181R22J	R,METAL OXIDE 0.22 OHM 1W
△R602	AD301975	R3X28B120J	R,METAL OXIDE 12 OHM 3W
△R649	AD302271	R3X28B5R6J	R,METAL OXIDE 5.6 OHM 3W
△R803	BZ210026	R3X18A153J	R,METAL OXIDE 15K OHM 2W
△R805	BZ210026	R3X18A153J	R,METAL OXIDE 15K OHM 2W
△R807	BZ210026	R3X18A153J	R,METAL OXIDE 15K OHM 2W
<b>CAPACITORS</b>			
C408	BZ110032	E5EZFD3102M	CE 1000 UF 25V
C412	AD301318	P4N8FJ471J	CMPP 470 PF 1.25KV
△C413	AD301977	E0ELF4102M	CE 1000 UF 35V
C418	AD301144	P4J7F3274J	CMPP 0.27 UF 250V PMS
△C420	BZ110218	P4N8FJ103H	CMPP 0.01 UF 1.25KV
C425	BZ110202	C0PLRR713K	CC 0.001 UF 2KV R
△C426	AD300061	E5EZFD220M	CE 22 UF 250V
△C430	BZ110195	E02LU8220M	CE 22 UF 100V
△C501	BZ110053	E02LF3102M	CE 1000 UF 25V
C502	BZ110202	C0PLRR713K	CC 0.001 UF 2KV R
C503	BZ110202	C0PLRR713K	CC 0.001 UF 2KV R
△C504	AD301729	E02LU52R2M	CE 2.2 UF 50V
△C505	BZ110025	P2122B224M	CMP 0.22 UF 275V ECQUL
△C506	BZ110035	P2122B104M	CMP 0.1 UF 275V ECQUL
△C507	AD301635	E51CGC331M	CE 330 UF 200V
△C508	AD301108	CD39E0MH3M	CC 0.0022UF 250V
△C513	AD301026	CD39E0M13M	CC 0.001 UF 250V
C517	BZ110191	C03L0R7E3K	CC 0.0015UF 2KV R
△C519	AD301026	CD39E0M13M	CC 0.001 UF 250V
△C521	AD300060	E62NFB101M	CE 100 UF 160V
△C527	BZ110119	E02LF2222M	CE 2200 UF 16V
C535	BZ110202	C0PLRR713K	CC 0.001 UF 2KV R
C802	BZ110247	C0JBB0713K	CC 0.001 UF 2KV B
C1003	BZ110053	E02LF3102M	CE 1000 UF 25V
C1004	BZ110053	E02LF3102M	CE 1000 UF 25V
C1009	BZ110053	E02LF3102M	CE 1000 UF 25V
<b>DIODES</b>			
D001	BZ410037	D97U03301B	DIODE,ZENER MTZJ33B T-77
D104	BZ410006	D1VT001330	DIODE,SILICON 1SS133T-77
D105	BZ410006	D1VT001330	DIODE,SILICON 1SS133T-77
D106	BZ410020	D97U05R11B	DIODE,ZENER MTZJ5.1B T-77
D109	BZ410054	0021721150	LED SLR-342VCT32
D113	BZ410021	D97U05R61B	DIODE,ZENER MTZJ5.6B T-77
D402	BZ410043	D2WT011E10	DIODE,SILICON 11E1-EIC
D403	BZ410019	D97U03001B	DIODE,ZENER MTZJ30B T-77
D404	BZ410020	D97U05R11B	DIODE,ZENER MTZJ5.1B T-77
△D405	BZ410063	D2WTAU02A0	DIODE,SILICON AU02A-EIC
△D406	BZ410021	D97U05R61B	DIODE,ZENER MTZJ5.6B T-77
△D407	BZ410063	D2WTAU02A0	DIODE,SILICON AU02A-EIC
D410	BZ410019	D97U03001B	DIODE,ZENER MTZJ30B T-77
△D411	BZ410063	D2WTAU02A0	DIODE,SILICON AU02A-EIC
D414	BZ410043	D2WT011E10	DIODE,SILICON 11E1-EIC
D415	BZ410043	D2WT011E10	DIODE,SILICON 11E1-EIC
△D501	BZ410062	D2WTRM11C0	DIODE,SILICON RM11C-EIC
△D502	BZ410062	D2WTRM11C0	DIODE,SILICON RM11C-EIC
△D503	BZ410062	D2WTRM11C0	DIODE,SILICON RM11C-EIC
△D504	BZ410062	D2WTRM11C0	DIODE,SILICON RM11C-EIC
△D505	AD300076	D28F30DF60	DIODE,RECTIFIER 30DF6-FC

# ELECTRICAL REPLACEMENT PARTS LIST

Location No.	TSB P/N	Reference No.	Description
<b>DIODES</b>			
△D506	AD300731	D2WXN49370	DIODE,SILICON 1N4937
D507	BZ410006	D1VT001330	DIODE,SILICON 1SS133T-77
D508	BZ410064	D97U03R91B	DIODE,ZENER MTZJ3.9B T-77
D509	AD300671	D97U01801B	DIODE,ZENER MTZJ18B T-77
△D510	AD301980	D2CF2016L0	DIODE,SILICON FE201-6L49
△D511	AD300731	D2WXN49370	DIODE,SILICON 1N4937
△D512	BZ410010	D28T21DQN9	DIODE,SCHOTTKY 21DQ09N-TA2B1
D513	BZ410006	D1VT001330	DIODE,SILICON 1SS133T-77
D514	BZ410006	D1VT001330	DIODE,SILICON 1SS133T-77
D516	BZ410006	D1VT001330	DIODE,SILICON 1SS133T-77
D517	BZ410006	D1VT001330	DIODE,SILICON 1SS133T-77
D520	BZ410006	D1VT001330	DIODE,SILICON 1SS133T-77
△D523	AD300671	D97U01801B	DIODE,ZENER MTZJ18B T-77
D524	BZ410006	D1VT001330	DIODE,SILICON 1SS133T-77
D525	AD300070	D97U01201B	DIODE,ZENER MTZJ12B T-77
D528	BZ410021	D97U05R61B	DIODE,ZENER MTZJ5.6B T-77
D601	BZ410006	D1VT001330	DIODE,SILICON 1SS133T-77
D602	BZ410058	D97U08R21B	DIODE,ZENER MTZJ8.2B T-77
D603	AD300670	D97U01501B	DIODE,ZENER MTZJ15B T-77
D604	AD300070	D97U01201B	DIODE,ZENER MTZJ12B T-77
D605	BZ410006	D1VT001330	DIODE,SILICON 1SS133T-77
D606	BZ410006	D1VT001330	DIODE,SILICON 1SS133T-77
D607	BZ410006	D1VT001330	DIODE,SILICON 1SS133T-77
D608	BZ410043	D2WT011E10	DIODE,SILICON 11E1-EIC
D701	AD300070	D97U01201B	DIODE,ZENER MTZJ12B T-77
D702	AD300070	D97U01201B	DIODE,ZENER MTZJ12B T-77
D703	AD300070	D97U01201B	DIODE,ZENER MTZJ12B T-77
D704	AD300070	D97U01201B	DIODE,ZENER MTZJ12B T-77
D705	AD300070	D97U01201B	DIODE,ZENER MTZJ12B T-77
D706	AD300070	D97U01201B	DIODE,ZENER MTZJ12B T-77
D709	BZ410066	D97U06R21B	DIODE,ZENER MTZJ6.2B T-77
D801	BZ410006	D1VT001330	DIODE,SILICON 1SS133T-77
D802	BZ410006	D1VT001330	DIODE,SILICON 1SS133T-77
D803	BZ410006	D1VT001330	DIODE,SILICON 1SS133T-77
D810	BZ410006	D1VT001330	DIODE,SILICON 1SS133T-77
D811	BZ410006	D1VT001330	DIODE,SILICON 1SS133T-77
D812	BZ410006	D1VT001330	DIODE,SILICON 1SS133T-77
D1001	AD300070	D97U01201B	DIODE,ZENER MTZJ12B T-77
<b>ICS</b>			
IC101	AD301981	I56F07090A	IC OEC7090A
IC199	AD302274	A3M801J015	IC S-24C16AFJA-TB-01
IC302	AD301983	I01FF58910	IC AN5891SA-E1V
△IC401	AE002783	I03TD804N0	IC LA78040N-E
△IC504	BZ410088	0002E00610	PHOTO COUPLER LTV-817M-VB
IC601	AE002803	I06FC1283A	IC M61283FP R70T
IC701	AD301988	I0UF015010	IC MM1501XNRE
IC702	AD301988	I0UF015010	IC MM1501XNRE
IC902	AD300059	I01FF58290	IC AN5829S
△IC1001	AE003081	I0FSP7808B	IC AN17808B
IC1501	AE003002	I03FE76605	IC LA76605M-TLM
IC1502	AD301988	I0UF015010	IC MM1501XNRE
IC1503	AD301988	I0UF015010	IC MM1501XNRE
<b>TRANSISTORS</b>			
Q101	BZ510109	TCAA3875SY	TRANSISTOR,SILICON KTC3875S_Y_RTK
Q103	BZ510109	TCAA3875SY	TRANSISTOR,SILICON KTC3875S_Y_RTK
△Q402	BZ510097	TCAT03227Y	TRANSISTOR,SILICON KTC3227_Y-AT
△Q405	BZ510040	TDUU024990	TRANSISTOR,SILICON 2SD2499(LB0EC1)
△Q502	BZ510098	T220033260	FET 2SK3326(2)
△Q503	BZ510005	TA3T1371A0	TRANSISTOR,SILICON 2SA1371(D,E)-AE
Q504	BZ510069	TCATC31980	TRANSISTOR,SILICON KTC3198-AT(Y,GR)
△Q505	BZ510011	TC3T029090	TRANSISTOR,SILICON 2SC2909(S,T)-AA
△Q507	BZ510069	TCATC31980	TRANSISTOR,SILICON KTC3198-AT(Y,GR)
△Q508	BZ510077	TAAT012714	TRANSISTOR,SILICON KTA1271_Y-AT
Q509	BZ510069	TCATC31980	TRANSISTOR,SILICON KTC3198-AT(Y,GR)
△Q512	BZ510004	TA3T016240	TRANSISTOR,SILICON 2SA1624-AA
△Q514	BZ510070	TCAT032034	TRANSISTOR,SILICON KTC3203_Y-AT
Q601	BZ510105	TCAT03209Y	TRANSISTOR,SILICON KTC3209_Y-AT
Q602	BZ510105	TCAT03209Y	TRANSISTOR,SILICON KTC3209_Y-AT
Q603	BZ510109	TCAA3875SY	TRANSISTOR,SILICON KTC3875S_Y_RTK
Q604	BZ510105	TCAT03209Y	TRANSISTOR,SILICON KTC3209_Y-AT
Q605	BZ510109	TCAA3875SY	TRANSISTOR,SILICON KTC3875S_Y_RTK

# ELECTRICAL REPLACEMENT PARTS LIST

Location No.	TSB P/N	Reference No.	Description
<b>TRANSISTORS</b>			
Q606	BZ510105	TCAT03209Y	TRANSISTOR,SILICON KTC3209_Y-AT
Q607	BZ510070	TCAT032034	TRANSISTOR,SILICON KTC3203_Y-AT
Q611	BZ510105	TCAT03209Y	TRANSISTOR,SILICON KTC3209_Y-AT
Q614	BZ510108	TAAA1504SY	TRANSISTOR,SILICON KTA1504S_Y_RTK
△Q801	AD301032	TCATC3199Y	TRANSISTOR,SILICON KTC3199_Y-AT
△Q802	AD301032	TCATC3199Y	TRANSISTOR,SILICON KTC3199_Y-AT
△Q803	AD301032	TCATC3199Y	TRANSISTOR,SILICON KTC3199_Y-AT
△Q804	BZ510091	TCA0042170	TRANSISTOR,SILICON KTC4217(O,Y)
△Q805	BZ510091	TCA0042170	TRANSISTOR,SILICON KTC4217(O,Y)
△Q806	BZ510091	TCA0042170	TRANSISTOR,SILICON KTC4217(O,Y)
Q901	BZ510108	TAAA1504SY	TRANSISTOR,SILICON KTA1504S_Y_RTK
Q902	BZ510108	TAAA1504SY	TRANSISTOR,SILICON KTA1504S_Y_RTK
Q1001	BZ510068	TNAAJ05003	COMPOUND TRANSISTOR KRC111SRTK
Q1503	BZ510109	TCAA3875SY	TRANSISTOR,SILICON KTC3875S_Y_RTK
Q1504	BZ510109	TCAA3875SY	TRANSISTOR,SILICON KTC3875S_Y_RTK
Q1507	BZ510109	TCAA3875SY	TRANSISTOR,SILICON KTC3875S_Y_RTK
Q1508	BZ510109	TCAA3875SY	TRANSISTOR,SILICON KTC3875S_Y_RTK
<b>COILS &amp; TRANSFORMERS</b>			
L301	BZ310041	02167F101J	COIL 100 UH
L401	BZ310004	021679472K	COIL 4.7 MH
L402	BZ310013	0221000013	COIL,LINEARITY ELH5L4112N
△L501	AD300119	029T000097	COIL,LINE FILTER 1R5A123F28Y
△L503	BZ310116	028R140023	COIL,DEGAUSS 8R140023
L901	BZ310041	02167F101J	COIL 100 UH
L1501	BZ310041	02167F101J	COIL 100 UH
L1502	AD301417	02167F221J	COIL 220 UH
L1503	AD301417	02167F221J	COIL 220 UH
L1505	AD300613	02167F150J	COIL 15 UH
L1508	BZ310041	02167F101J	COIL 100 UH
L1510	AD300613	02167F150J	COIL 15 UH
L1511	AD300613	02167F150J	COIL 15 UH
L1512	AD301608	0216A6220J	COIL 22 UH
T401	BZ310172	045013003J	TRANS,HORIZONTAL DRIVE ETH14Y47AY
△T501	AD301146	0481290914	TRANSFORMER,SWITCHING 81290914
<b>JACKS</b>			
J701	AD301038	060J431019	RCA JACK MSP-213V2-432 PBSN
J702	AD300108	063Q700002	JACK YKF51-5503
J703	AD301038	060J431019	RCA JACK MSP-213V2-432 PBSN
J704	AD301037	060J411024	RCA JACK MSP-213V1-652 PBSN
J705	AD300110	060G401047	RCA JACK HTJ-032-03AY
J706	AD300111	060G401046	RCA JACK HTJ-032-03AW
J707	AD300112	060G401039	RCA JACK HTJ-032-03AR
△J801	AD301147	066F120018	SOCKET,CATHODE RAY TUBE ISMS01S
J1001	BZ614361	060J131015	HEADPHONE JACK MSJ-2000
<b>SWITCHES</b>			
SW101	BZ612010	0504101T34	SWITCH,TACT EVQ21505R
SW102	BZ612010	0504101T34	SWITCH,TACT EVQ21505R
SW103	BZ612010	0504101T34	SWITCH,TACT EVQ21505R
SW104	BZ612010	0504101T34	SWITCH,TACT EVQ21505R
SW105	BZ612010	0504101T34	SWITCH,TACT EVQ21505R
<b>VARIABLE RESISTORS</b>			
VR401	BZ210218	V1K63H3BTE	VOLUME,SEMI FIXED NVG6TLTAB222
VR502	BZ210101	V1163H4BTC	VOLUME,SEMI FIXED EVNCYAA03BE4
<b>P.C.BOARD ASSEMBLIES</b>			
PCB010	AE003157	A3M813J010	PCB ASS'Y TMC559D
PCB110	AE003158	A3M813J110	PCB ASS'Y TCC421D
<b>MISCELLANEOUS</b>			
B405	BZ310129	024HT03564	CORE,BEADS W4BRH3.5X6X1.0
B501	BZ310045	024AT03481	CORE,BEADS BL02RN1-R62T2
B504	BZ310121	024HT03553	CORE,BEADS W5RH3.5X5X1.0
BT001	AE000012	1412004008	BATTERY,MANGAN R03(AB)E_2P_G
BT002	AE000012	1412004008	BATTERY,MANGAN R03(AB)E_2P_G
△CD501	AE000566	1209619901	CORD,AC BUSH 9619901
CD801	AE000567	WCL6826038	FLAT CABLE AWM2468 AWG26 5C GRAY 260MM
CD802	AE000568	WEL6836038	FLAT CABLE AWM2468 AWG26 7C GRAY 360MM
CD803	AD301363	06CU822501	CORD,CONNECTOR CU822501
CP101	BZ614102	0694270139	CONNECTOR PCB SIDE 173979-7
△CP401	AD300095	069X460029	CONNECTOR PCB SIDE B06B-DVS
△CP501	BZ614176	069S320419	CONNECTOR PCB SIDE A3963WV2-3PD
△CP502	AD300687	069S420110	CONNECTOR PCB SIDE A1561WV2-2P
CP507	BZ614444	069D01001A	CONNECTOR PCB SIDE 003P-2100

# ELECTRICAL REPLACEMENT PARTS LIST

Location No.	TSB P/N	Reference No.	Description
<b>SWITCHES</b>			
CP508	BZ614444	069D01001A	CONNECTOR PCB SIDE 003P-2100
CP803	BZ614269	069S320010	CONNECTOR PCB SIDE A2361WV2-2P
CP806	BZ614058	069W010010	CONNECTOR PCB SIDE 005P-2100
CD1001	AE000569	06CU146901	CORD,CONNECTOR CU146901
CP1001	AD301045	069S140419	CONNECTOR PCB SIDE A2502WV2-4P
CP801A	BZ614276	067U005049	WIRE HOLDER B2013H02-5P
CP801B	BZ614276	067U005049	WIRE HOLDER B2013H02-5P
CP802A	AD301997	067U007029	WIRE HOLDER B2013H02-7P
CP802B	AD301997	067U007029	WIRE HOLDER B2013H02-7P
EL001	BZ614044	124120301A	EYE LET XRY20X30BD
EL002	BZ614043	124116281A	EYE LET XRY16X28BD
△F501	AD301046	081PC6R305	FUSE 51MS063L
△FB401	AE003159	043214045F	TRANSFORMER,FLYBACK FQI14B003F_M
FH501	AE002634	06710T0009	HOLDER,FUSE EYF-52BCY
FH502	AE002634	06710T0009	HOLDER,FUSE EYF-52BCY
OS101	AD301048	0773071001	REMOTE RECEIVER RPM7138-WH5
△RY501	AD300114	0560V20115	RELAY ALKS321
SP1001	BZ614029	070C533008	SPEAKER 810-47-171
SP1002	BZ614029	070C533008	SPEAKER 810-47-171
△TH501	BZ410079	DF5EL3R0A0	DEGAUSS ELEMENT ZPB45BL3R0A
TM101	AE003009	076R0GW020	TRANSMITTER R25-1943
△TU001	AE000273	0163300005	RF UNIT 115-V-K015AR_B
△V801	AE003160	098Q150408	CRT W/DY A36AKJ13X05(U)
X101	AD302002	100CT8R005	CRYSTAL HC-49/U-S
X602	AD302003	100CT3R505	CRYSTAL HC-49/C
RESISTOR			
	RC.....	CARBON RESISTOR	
CAPACITORS			
	CC.....	CERAMIC CAPACITOR	
	CE.....	ALUMI ELECTROLYTIC CAPACITOR	
	CP.....	POLYESTER CAPACITOR	
	CPP.....	POLYPROPYLENE CAPACITOR	
	CPL.....	PLASTIC CAPACITOR	
	CMP.....	METAL POLYESTER CAPACITOR	
	CMPL.....	METAL PLASTIC CAPACITOR	
	CMPP.....	METAL POLYPROPYLENE CAPACITOR	

# **TOSHIBA CORPORATION**

1-1, SHIBAURA 1-CHOME, MINATO-KU, TOKYO 105-8001, JAPAN