

# KV-27V55 / 29V55M

## RM-Y119

# SERVICE MANUAL

*US Model*

*KV-27V55*

*Chassis No. SCC-F84H-A*

*Canadian Model*

*KV-27V55*

*Chassis No. SCC-F85E-A*

*E Model*

*KV-29V55M*

*Chassis No. SCC-F89D-A*

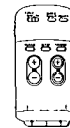
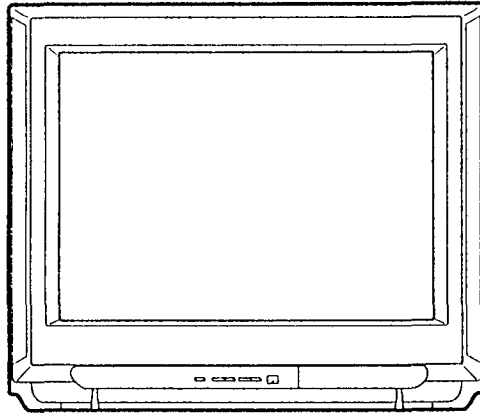

# AA-1 CHASSIS

### MODELS OF THE SAME SERIES

KV-27V55/29V55M	KV-27TS29/27TS32/27TS36
KV-27TW77/27TW78	KV-32TS36/32TS46
KV-32TW77/32TW78	KV-2970RS/2970M/2975M

### SPECIFICATIONS

<b>Television system</b>	American TV standards	<b>Output</b>	AUDIO OUT (phono jacks) More than 900 mVrms at the maximum volume setting (variable) More than 500 mVrms (fix) Impedances: 5 kilohms		
<b>Channel coverage</b>	VHF 2-13 UHF 14-69 Cable TV: 1-125	<b>Speaker output</b>	15 W x 2		
<b>Picture tube</b>	Hi-Black Trinitron® tube 27-inch picture measured diagonally 29-inch picture tube measured diagonally (KV-27V55/29V55M)	<b>Power requirements</b>	120 V AC, 60 Hz		
<b>Antenna</b>	75-ohm external antenna terminal for VHF/UHF	<b>Power consumption</b>	<table border="1"> <tbody> <tr> <td>KV-27V55 KV-29V55M</td> <td>210 W (standby mode: 5W)</td> </tr> </tbody> </table>	KV-27V55 KV-29V55M	210 W (standby mode: 5W)
KV-27V55 KV-29V55M	210 W (standby mode: 5W)				
<b>Input</b>	VIDEO and S VIDEO S VIDEO IN (S terminal) Y: 1 Vp-p, 75-ohms unbalanced, sync negative C: 0.286 Vp-p (Burst signal), 75-ohms Video (phono jacks) 1 Vp-p, 75-ohms unbalanced, sync negative Audio (phono jacks): 500 mVrms (100% modulation) Impedance: 47 kilohms				

— Continued on next page —



TRINITRON® COLOR TV  
**SONY®**

**Dimensions/Mass**

	Dimensions (w/h/d)	Mass
KV-27V55	711.2 × 572 × 525.2 mm (28 × 22 <sup>5</sup> / <sub>8</sub> × 20 <sup>3</sup> / <sub>4</sub> in.)	52 kg (114 lbs 11 oz)
KV-29V55M	711.2 × 572 × 525.2 mm (28 × 22 <sup>5</sup> / <sub>8</sub> × 20 <sup>3</sup> / <sub>4</sub> in.)	47 kg (103 lbs 10 oz)

**Supplied accessories**

Remote Commander RM-Y119 (1) with  
1 size AA (R6) EVEREADY battery

**Recommended accessories**

U/V mixer EAC-66  
Connecting cable  
VMC-810S/820S, VMC-720M,  
YC-15V/30V, RK-74A

Design and specifications are subject to change without  
notice.

**(CAUTION)**

SHORT CIRCUIT THE ANODE OF THE PICTURE TUBE AND THE ANODE CAP TO THE METAL CHASSIS, CRT SHIELD, OR CARBON PAINTED ON THE CRT, AFTER REMOVING THE ANODE.

**WARNING!!**

AN ISOLATION TRANSFORMER SHOULD BE USED DURING ANY SERVICE TO AVOID POSSIBLE SHOCK HAZARD, BECAUSE OF LIVE CHASSIS.  
THE CHASSIS OF THIS RECEIVER IS DIRECTLY CONNECTED TO THE AC POWER LINE.

**SAFETY-RELATED COMPONENT WARNING !!**

COMPONENTS IDENTIFIED BY SHADING AND MARK  $\Delta$  ON THE SCHEMATIC DIAGRAMS, EXPLODED VIEWS AND IN THE PARTS LIST ARE CRITICAL TO SAFE OPERATION. REPLACE THESE COMPONENTS WITH SONY PARTS WHOSE PART NUMBERS APPEAR AS SHOWN IN THIS MANUAL OR IN SUPPLEMENTS PUBLISHED BY SONY. CIRCUIT ADJUSTMENTS THAT ARE CRITICAL TO SAFE OPERATION ARE IDENTIFIED IN THIS MANUAL. FOLLOW THESE PROCEDURES WHENEVER CRITICAL COMPONENTS ARE REPLACED OR IMPROPER OPERATION IS SUSPECTED.

**(ATTENTION)**

APRES AVOIR DECONNECTE LE CAP DE L'ANODE, COURT-CIRCUITER L'ANODE DU TUBE CATHODIQUE ET CELUI DE L'ANODE DU CAP AU CHASSIS METALLIQUE DE L'APPAREIL, OU AU COUCHE DE CARBONE PEINTE SUR LE TUBE CATHODIQUE OU AU BLINDAGE DU TUBE CATHODIQUE.

**ATTENTION!!**

AFIN D'EVITER TOUT RISQUE D'ELECTROCUTION PROVENANT D'UN CHASSIS SOUS TENSION, UN TRANSFORMATEUR D'ISOLEMENT DOIT ETRE UTILISE LORS DE TOUT DEPANNAGE.  
LE CHASSIS DE CE RECEPTEUR EST DIRECTEMENT RACCORDE A L'ALIMENTATION SECTEUR.

**ATTENTION AUX COMPOSANTS RELATIFS A LA SECURITE!!**

LES COMPOSANTS IDENTIFIES PAR UNE TRAME ET PAR UNE MAPQUE  $\Delta$  SUR LES SCHEMAS DE PRINCIPE, LES VUES EXPLOSEES ET LES LISTES DE PIECES CONT D'UNE IMPORTANCE CRITIQUE POUR LA SECURITE DU FONCTIONNEMENT. NE LES REMPLACER QUE PAR DES COMPOSANTS SONY DONT LE NUMERO DE PIECE EST INDIQUE DANS LE PRESENT MANUEL OU DANS DES SUPPLEMENTS PUBLIES PAR SONY. LES REGLAGES DE CIRCUIT DONT L'IMPORTANCE EST CRITIQUE POUR LA SECURITE DU FONCTIONNEMENT SONT IDENTIFIES DANS LE PRESENT MANUEL. SUIVRE CES PROCEDURES LORS DE CHAQUE REMPLACEMENT DE COMPOSANTS CRITIQUES, OU LORSQU'UN MAUVAIS FONCTIONNEMENT EST SUSPECTE.

## SAFETY CHECK-OUT (US Model Only)

After correcting the original service problem, perform the following safety checks before releasing the set to the customer:

1. Check the area of your repair for unsoldered or poorly-soldered connections. Check the entire board surface for solder splashes and bridges.
2. Check the interboard wiring to ensure that no wires are "pinched" or contact high-wattage resistors.
3. Check that all control knobs, shields, covers, ground straps, and mounting hardware have been replaced. Be absolutely certain that you have replaced all the insulators.
4. Look for unauthorized replacement parts, particularly transistors, that were installed during a previous repair. Point them out to the customer and recommend their replacement.
5. Look for parts which, though functioning, show obvious signs of deterioration. Point them out to the customer and recommend their replacement.
6. Check the line cord for cracks and abrasion. Recommend the replacement of any such line cord to the customer.
7. Check the condition of the monopole antenna (if any). Make sure the end is not broken off, and has the plastic cap on it. Point out the danger of impalement on a broken antenna to the customer, and recommend the antenna's replacement.
8. Check the B+ and HV to see they are at the values specified. Make sure your instruments are accurate; be suspicious of your HV meter if sets always have low HV.
9. Check the antenna terminals, metal trim, "metallized" knobs, screws, and all other exposed metal parts for AC leakage. Check leakage as described below.

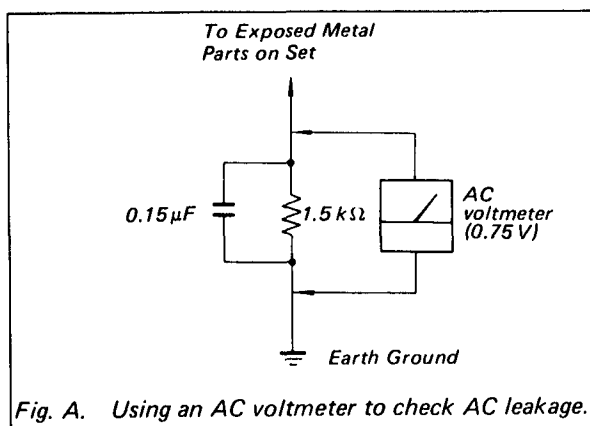

### LEAKAGE TEST

The AC leakage from any exposed metal part to earth ground and from all exposed metal parts to any exposed metal part having a return to chassis, must not exceed 0.5 mA (500 microamperes). Leakage current can be measured by any one of three methods.

1. A commercial leakage tester, such as the Simpson 229 or RCA WT-540A. Follow the manufacturers' instructions to use these instruments.
2. A battery-operated AC milliammeter. The Data Precision 245 digital multimeter is suitable for this job.
3. Measuring the voltage drop across a resistor by means of a VOM or battery-operated AC voltmeter. The "limit" indication is 0.75 V, so analog meters must have an accurate low-voltage scale. The Simpson 250 and Sanwa SH-63Trd are examples of a passive VOM that is suitable. Nearly all battery operated digital multimeters that have a 2V AC range are suitable. (See Fig. A)

### HOW TO FIND A GOOD EARTH GROUND

A cold-water pipe is guaranteed earth ground; the cover-plate retaining screw on most AC outlet boxes is also at earth ground. If the retaining screw is to be used as your earth-ground, verify that it is at ground by measuring the resistance between it and a cold-water pipe with an ohmmeter. The reading should be zero ohms. If a cold-water pipe is not accessible, connect a 60-100 watt trouble light (not a neon lamp) between the hot side of the receptacle and the retaining screw. Try both slots, if necessary, to locate the hot side of the line, the lamp should light at normal brilliance if the screw is at ground potential. (See Fig. B)

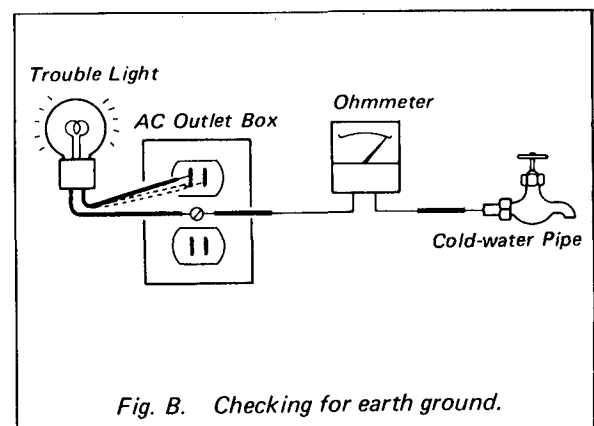

**TABLE OF CONTENTS**

<u>Section</u>	<u>Title</u>	<u>Page</u>	<u>Section</u>	<u>Title</u>	<u>Page</u>
<b>1. GENERAL</b>			<b>4. SAFETY RELATED ADJUSTMENTS</b>		39
1-1.	Locating the Controls	5	<b>5. CIRCUIT ADJUSTMENTS</b>		
1-2.	Using the On-Screen Menus	7	5-1.	Electrical Adjustment by Remote Commander	41
1-3.	Turning the Cable Mode On or Off	8	5-2.	M Board Adjustments	43
1-4.	Presetting TV Channels	9	5-3.	P Board Adjustments	45
1-5.	Connecting Other Equipment	11	<b>6. DIAGRAMS</b>		
1-6.	Watching TV Programs	14	6-1.	Block Diagrams	47
1-7.	Using Convenient Features	14	6-2.	Frame Schematic Diagram	57
1-8.	Using Closed Caption (except for KV-29V55M)	15	6-3.	Circuit Boards Location	60
1-9.	Watching Two Pictures at Once (Picture-in-Picture)	15	6-4.	Schematic Diagrams and Printed Wiring Boards	
1-10.	Using the Timer-Activated Functions	18	(1)	Schematic Diagram of D Board	61
1-11.	Customizing the Screen Display	21	(2)	Schematic Diagram of A, C and H Boards	69
1-12.	Using the Pre-Programmed Remote Commander	24	(3)	Schematic Diagram of UA Board	73
			(4)	Schematic Diagram of P Board	83
			(5)	Schematic Diagram of M Board	87
<b>2. DISASSEMBLY</b>			6-5.	Semiconductors	94
2-1.	Rear Cover Removal	26	<b>7. EXPLODED VIEWS</b>		
2-2.	Speaker Removal	26	7-1.	Chassis	95
2-3.	Chassis Assy Removal	26	7-2.	Picture Tube	96
2-4.	Service Position	27	<b>8. ELECTRICAL PARTS LIST</b>		97
2-5.	P Board and P Bracket Removal	27			
2-6.	UA Board Removal	28			
2-7.	Extension Cable	28			
2-8.	Picture Tube Removal	29			
2-9.	Repair of Chip Component Circuit Board	30			
<b>3. SET-UP ADJUSTMENTS</b>					
3-1.	Beam Landing	35			
3-2.	Convergence	36			
3-3.	Focus Adjustment	38			
3-4.	G2 (Screen) and White Balance Adjustments	38			

# SECTION 1 GENERAL

The operating instructions mentioned here are partial abstracts from the Operating Instruction Manual. The page numbers of the Operating Instruction Manual remain as in the manual.

## 1-1. LOCATING THE CONTROLS

### Screen Displays

For details, see the pages indicated by the numbered black circles ●

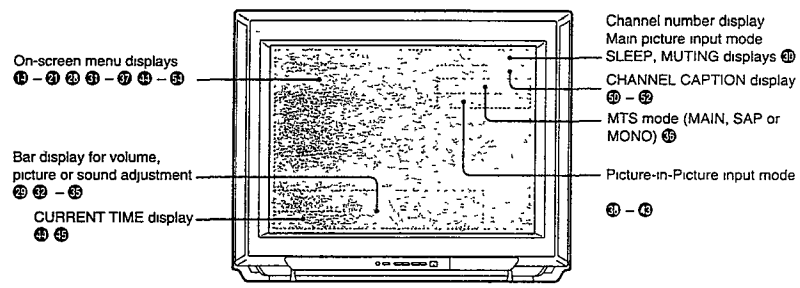

**KV-27V55**  
(The screen displays, except for certain features as noted above, are the same for all models )

### Front Panel

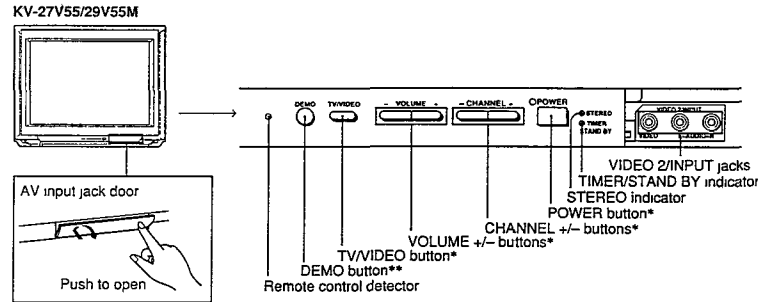

Rear Panel

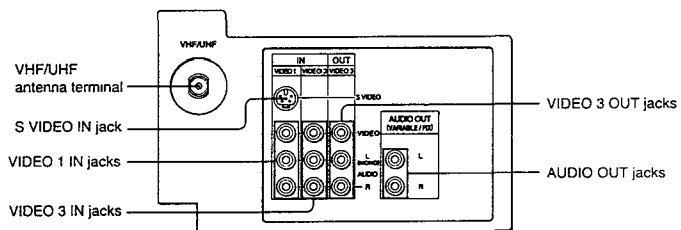

RM-Y119

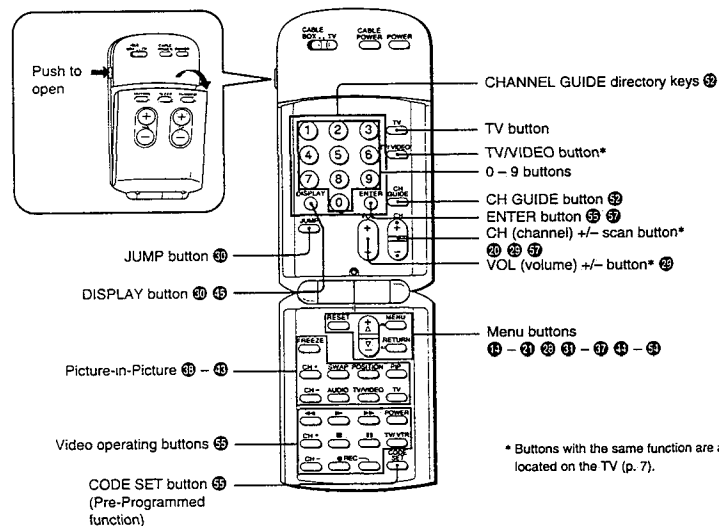
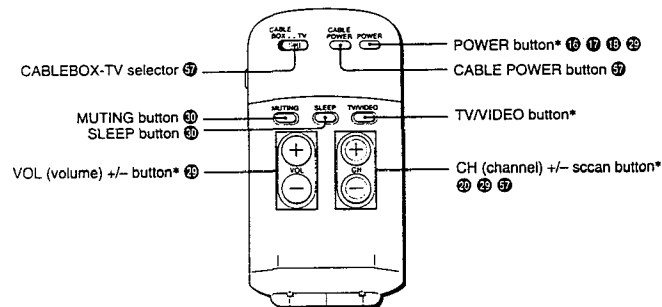

\* Buttons with the same function are also located on the TV (p. 7).

Installing Battery

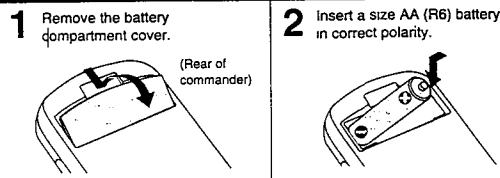

Note

If the TV/CABLE selector is set to CABLE, the Remote Commander is able to control a connected cable box, not the TV. Set the selector to TV to control the TV set with the Remote Commander (You can use POWER button at any case).

## 1-2. USING THE ON-SCREEN MENUS

The following flow chart shows the different levels of on-screen menus that you can use to make various adjustments and settings. See the indicated pages for instructions on using each feature.

### For picture quality adjustment



### For sound quality adjustment

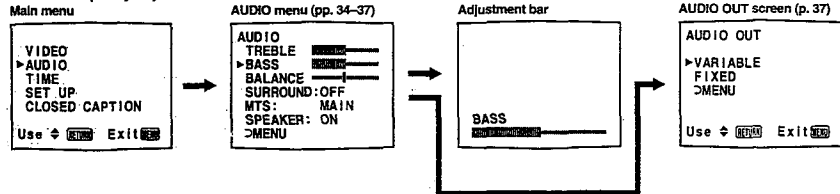

### For time-related settings

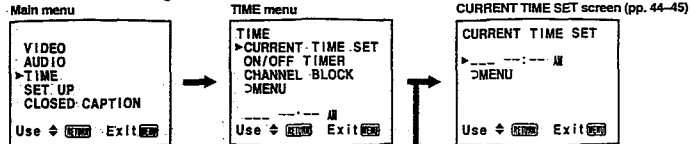

### For language setting (p. 16) (KV-29V55M only).

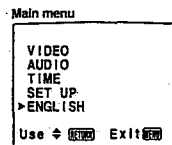

### ON/OFF TIMER screen (pp. 46-47)



### CHANNEL BLOCK screen (pp. 48-49)



### For presetting and other functions

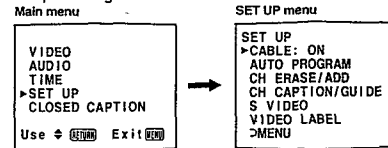

### For closed caption setting

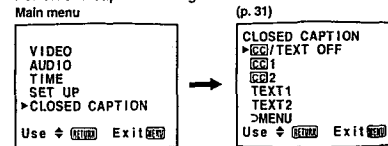

### CABLE ON/OFF screen (p. 17)

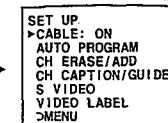

### AUTO PROGRAM screen (p. 18)



### CHANNEL ERASE/ADD screen (pp. 19-21)

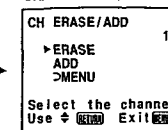

### CHANNEL CAPTION/GUIDE screen (pp. 50-51)

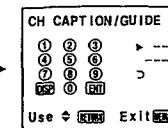

### S VIDEO ON/OFF screen (p. 28)

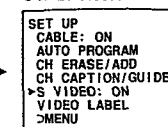

### VIDEO LABEL screen (pp. 53-54)

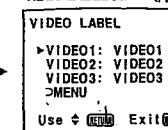

### Navigating through the Menus

#### Remote Commander

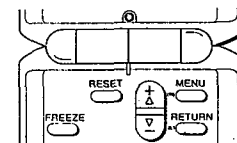

To display the main menu  
Press MENU.

To return to the previous menu  
Press Δ+ or ∇- to select "◀ MENU."  
Then press RETURN.

To return to the main menu  
Repeat the above, until you reach the main menu.

To return to the normal screen  
Press MENU on the Remote Commander.

#### Note

The menus disappear automatically if you do not press a button within 90 seconds.  
The menu you cannot select appears in black.

### 1-3. TURNING THE CABLE MODE ON OR OFF

If you have cable connected to your TV (pp. 12-13), follow the steps below to turn the cable connection on or off. CABLE is preset to ON when you use your TV for the first time. Then turn CABLE to OFF to preset or watch VHF or UHF channels (pp. 18-21 and 29).

**1** Press POWER on the TV or the Remote Commander to turn the TV on.  
The TIMER/STAND BY indicator blinks until the picture appears.

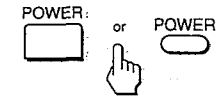

**2** Press MENU.  
The main menu appears.

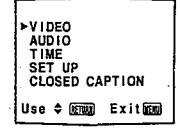

**3** Press  $\Delta$ + or  $\nabla$ - to select SET UP

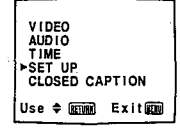
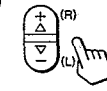

Press RETURN.  
The SET UP menu appears, and the cursor points to "CABLE".

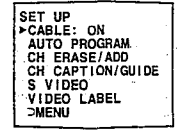

**Note**  
If the CABLE display appears in black, the TV is in VIDEO mode and you cannot select CABLE. Press TV or TV/VIDEO to change to TV mode.

**4** Press RETURN again.

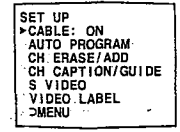

Press  $\Delta$ + or  $\nabla$ - to select ON or OFF alternately.

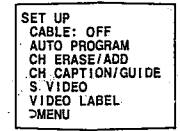
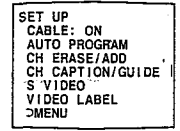

Press RETURN.  
The setting is completed.

### Changing the Menu Language (KV-29V55M only)

The menu language is factory-set to ENGLISH. Follow these instructions to change the menu language to Spanish or back to English.

**1** Press POWER on the TV or the Remote Commander to turn the TV on.  
The TIMER/STAND BY indicator blinks until the picture appears.

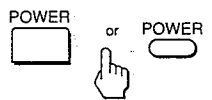

**2** Press MENU.  
The main menu appears.

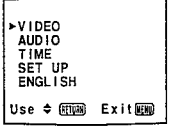

**3** Press  $\Delta$ + or  $\nabla$ - to select ENGLISH.  
Then press RETURN.

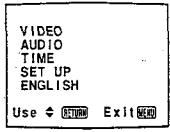

**4** Press  $\Delta$ + or  $\nabla$ - to select language.  
Each time you press  $\Delta$ + or  $\nabla$ -, ESPAÑOL and ENGLISH menus appear.

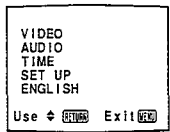
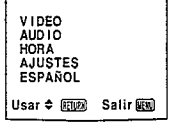
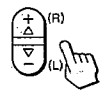

**Note**  
Certain parts of the ESPAÑOL menus remain in English.

**5** Press RETURN.  
The language is selected.

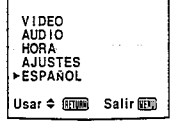

Spanish menu

To return to the normal screen  
Press MENU.

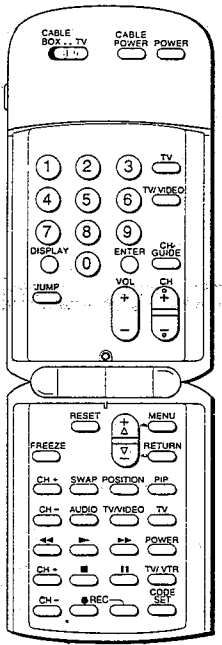

RM-Y119

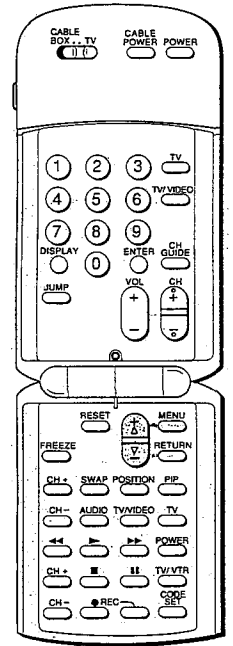

RM-Y119

To return to the normal screen  
Press MENU.

## 1-4. PRESETTING TV CHANNELS

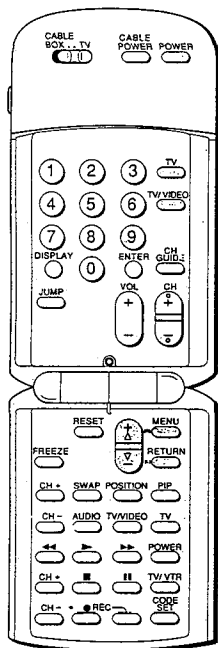
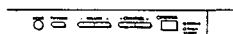

RM-Y119

Channels that can be received on this TV:

VHF	UHF	Cable
2-13	14-69	1-125

### Presetting TV Channels Automatically

- 1 Press POWER on the TV or the Remote Commander to turn the TV on. The **TIMER/STAND BY** indicator blinks until the picture appears.

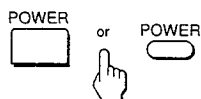

- 2 Set the cable connection on or off, depending on if you want to preset cable or VHF/UHF channels. (Follow the steps in "Turning the Cable Mode On or Off", p. 17)

- 3 Press MENU. The main menu appears.



VIDEO  
AUDIO  
TIME  
SET UP  
CLOSED CAPTION  
Use  $\leftarrow$  RETURN Exit  $\rightarrow$

- 4 Press  $\Delta$  or  $\nabla$  to select SET UP. Then press RETURN. The SET UP menu appears.



SET UP  
CABLE: ON  
AUTO PROGRAM  
CH ERASE/ADD  
CH CAPTION/GUIDE  
S VIDEO  
VIDEO LABEL  
>MENU

#### Note

If the AUTO PROGRAM display appears in black, the TV is in video mode and you cannot select AUTO PROGRAM. Press TV or TV/VIDEO to change to TV mode.

- 5 Press  $\Delta$  or  $\nabla$  to select AUTO PROGRAM. Then press RETURN.

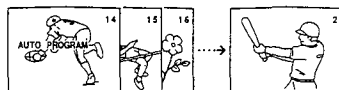

SET UP  
CABLE: ON  
AUTO PROGRAM  
CH ERASE/ADD  
CH CAPTION/GUIDE  
S VIDEO  
VIDEO LABEL  
>MENU

"AUTO PROGRAM" appears on the screen and receivable channels (other than the channels already preset) are preset in numerical sequence. The channels previously preset will not remain in the TV's memory.

When no more channels can be found, the programming stops and the lowest numbered channel is displayed.

To erase unnecessary channels, or to add channels that could not be preset automatically because their signal was too weak, follow the steps in "Erasing Unnecessary Channels — CHANNEL ERASE" (pp. 19–20) and "Presetting Only Desired Channels — CHANNEL ADD" (p. 21).

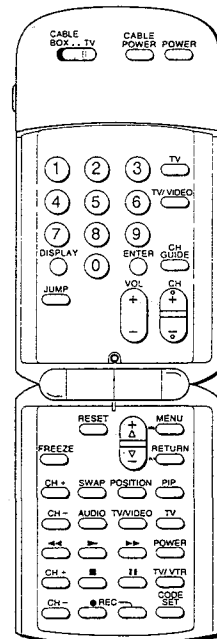

RM-Y119

### Erasing Unnecessary Channels—CHANNEL ERASE

Use this feature to erase unnecessary TV channels, so that when you press CH +/-, the channel(s) are skipped.

- 1 Press MENU. The main menu appears.



VIDEO  
AUDIO  
TIME  
SET UP  
CLOSED CAPTION  
Use  $\leftarrow$  RETURN Exit  $\rightarrow$

- 2 Press  $\Delta$  or  $\nabla$  to select SET UP



VIDEO  
AUDIO  
TIME  
SET UP  
CLOSED CAPTION  
Use  $\leftarrow$  RETURN Exit  $\rightarrow$

Press RETURN.

The SET UP menu appears.



SET UP  
CABLE: ON  
AUTO PROGRAM  
CH ERASE/ADD  
CH CAPTION/GUIDE  
S VIDEO  
VIDEO LABEL  
>MENU

- 3 Press  $\Delta$  or  $\nabla$  to select CH ERASE/ADD.



SET UP  
CABLE: ON  
AUTO PROGRAM  
CH ERASE/ADD  
CH CAPTION/GUIDE  
S VIDEO  
VIDEO LABEL  
>MENU

Press RETURN.

The CH ERASE/ADD screen appears, and the cursor points to "ERASE".



CH ERASE/ADD 10  
>ERASE  
ADD  
>MENU  
Select the channel  
Use  $\leftarrow$  RETURN Exit  $\rightarrow$

#### Note

If CH ERASE/ADD display appears in black, the TV is in video mode and you cannot select CH ERASE/ADD. Press TV or TV/VIDEO to change to TV mode.

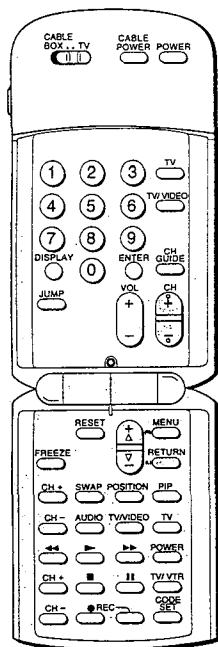

RM-Y119

To return to the normal screen  
Press MENU.

**Note**

When you erase a VHF or UHF channel, the cable TV channel with the same number is also erased, and vice versa.

**4** Press the CH +/- button to select the channel you want to erase.  
For example, to erase channel 8, press CH +/- until 8 appears.

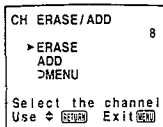
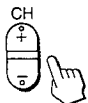

Press RETURN.

A "+" sign appears in front of the channel number display, indicating that the channel is erased from the channel scan memory.

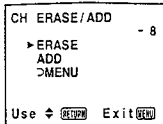

The next time you press the CH +/- buttons, channel 8 will be skipped.

To erase other channels  
Repeat step 4.

**Cable TV channel chart\***

Cable TV systems use letters or numbers to designate channels. To tune in a channel, refer to the chart below.

Number on this TV	Corresponding cable TV channel	Number on this TV	Corresponding cable TV channel
1	A-8	33	T
5	A-7	34	U
6	A-6	35	V
14	A	36	W
15	B	37	W+1
16	C	38	W+2
17	D	39	W+3
18	E		
19	F	93	W+57
20	G	94	W+58
21	H	95	A-5
22	I	96	A-4
23	J	97	A-3
24	K	98	A-2
25	L	99	A-1
26	M	100	W+59
27	N	101	W+60
28	O	102	W+61
29	P		
30	Q	123	W+82
31	R	124	W+83
32	S	125	W+84

\* This designation of cable TV channels conforms to the EIA/NCTA recommendation. Check with your local cable TV company for more complete information on the available channels.

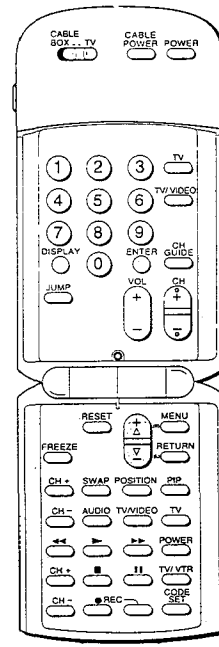

RM-Y119

To return to the normal screen  
Press MENU.

**Note**

If you add a VHF or UHF channel, the cable TV channel with the same number is also added, and vice versa.

**Presetting Only Desired Channels—CHANNEL ADD**

Use this feature to add channels one by one to the channel scan memory.

**1-3** (Follow steps 1-3 in "Erasing Unnecessary Channels—CHANNEL ERASE," p. 19.)

**Note**

If the CH ERASE/ADD display appears in black, the TV is in video mode and you cannot select CHANNEL ERASE/ADD. Press TV or TV/VIDEO to change to TV mode.

**4** Press Δ + or ∇ - to select ADD.

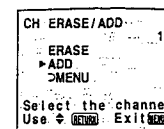

**5** Press 0-9 and ENTER to select the channel you want to add.  
For example, to add channel 25, press 2, 5 and ENTER.

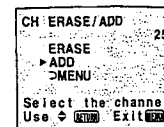
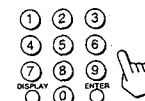

Press RETURN.

A "+" sign appears in front of the channel number display, indicating that the channel is added to the channel scan memory.

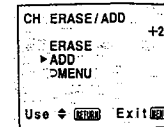

To add other channels  
Repeat step 5.

## 1-5. CONNECTING OTHER EQUIPMENT

### Video Equipment

After connecting, you will be able to...

- Play back video tapes
- Watch two TV programs at once using a window picture (Picture-in-Picture, pp. 38–43)

### Connecting a VCR with an S video output jack

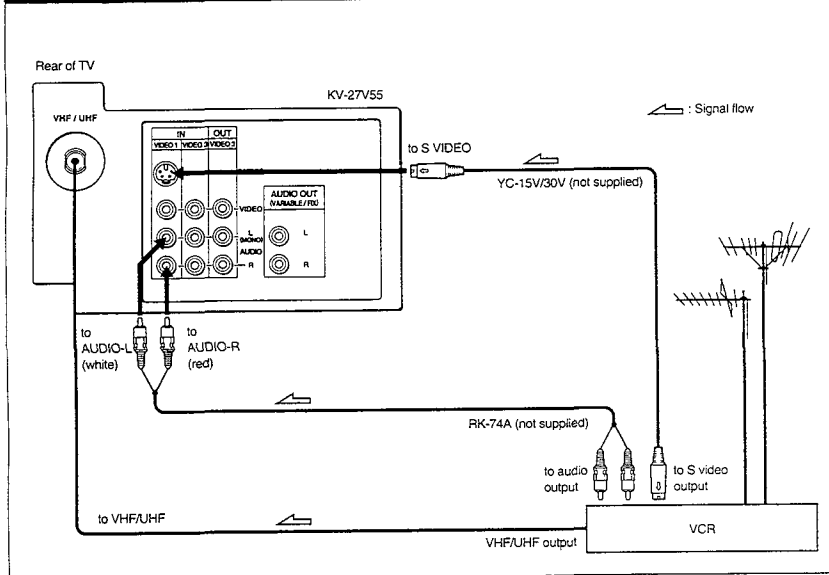

#### Notes

- If you connect a monaural VCR, connect the audio output of the VCR to the L (MONO) jack of VIDEO 1 IN on the TV. The monaural sound will be heard from both speakers.
- For operating instructions, refer to the instruction manual furnished with the VCR.
- If the picture or sound is affected, move the VCR away from the TV.
- If S VIDEO is set to OFF, you cannot watch VCR playback pictures from the S VIDEO IN. To set S VIDEO to ON, see "Watching a Video with Your S Video-Equipped VCR", p. 28.

#### About S video input

Video input and output signals can be separated into Y (luminance or brightness) and C (chroma or color) signals. Usually these two signals are combined in a VCR and sent as one signal to a TV. Separation of the Y and C signals prevents them from interfering with one another, thereby improving picture (especially color) quality. This TV is equipped with an S video input jack through which these separated signals can be input directly. This way you can connect your S video-equipped VCR separately from a non-S video VCR.

### Connecting video equipment not equipped with an S video output jack

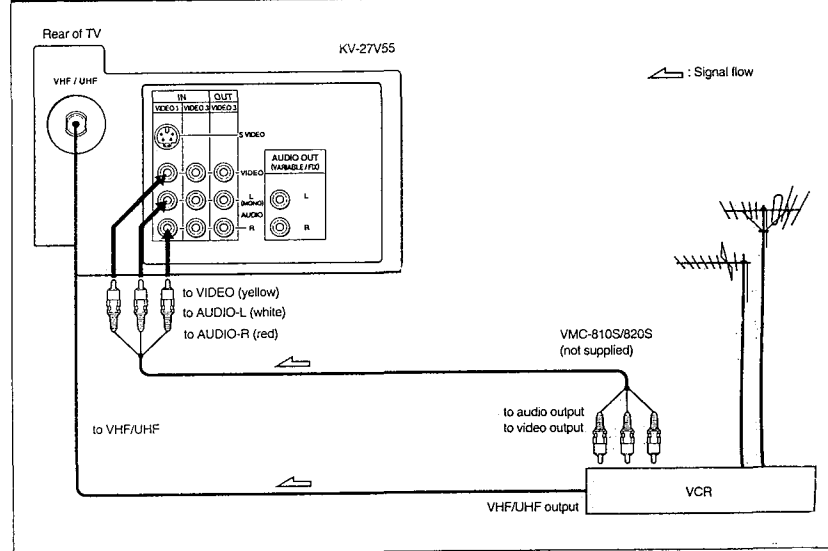

#### Preparing for use

- 1 Turn on the TV.
- 2 Press the TV/VIDEO button on the TV or on the Remote Commander so that VIDEO appears on the screen.

**When you cannot obtain a clear picture and/or sound**  
Make sure that the TV/VTR on the VCR is set to TV. Reselect the channel you want to view with the controls on the TV or the Remote Commander.

#### Operating your equipment

When using a Sony VCR, Multi-disc player or other manufacturer's infrared remote control VCR, you can operate most of the equipments by using the supplied pre-programmed Remote Commander (p. 55).

#### To return to TV mode

Press the TV or TV/VIDEO button so that a channel number appears on the screen.

**Connecting two VCRs for tape editing**

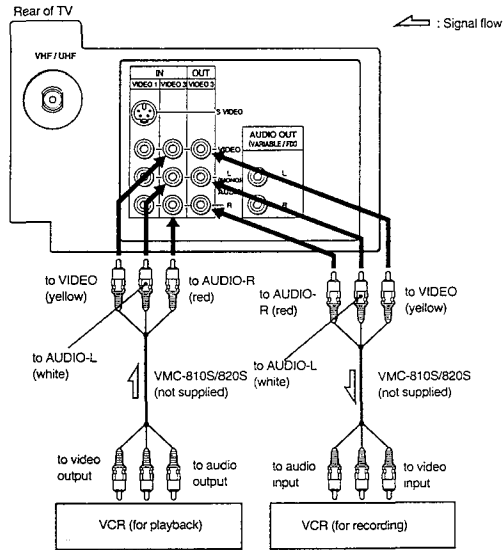

**Watching a different image while duplicating**

You can duplicate your recorded tapes by connecting two VCRs. The VIDEO 3 OUT jacks only output the signal from the VIDEO 3 IN jacks even when the TV is turned off. Connect a VCR for playback to VIDEO 3 IN jacks, and a VCR for recording to the VIDEO 3 OUT jacks. You can watch a TV program or images from VIDEO 1 IN or VIDEO 2 IN during duplicating.

**To watch a different input image**  
Press TV or TV/VIDEO to select the input image you want to watch.

**Connecting camcorders**

**Playing back recorded tapes**

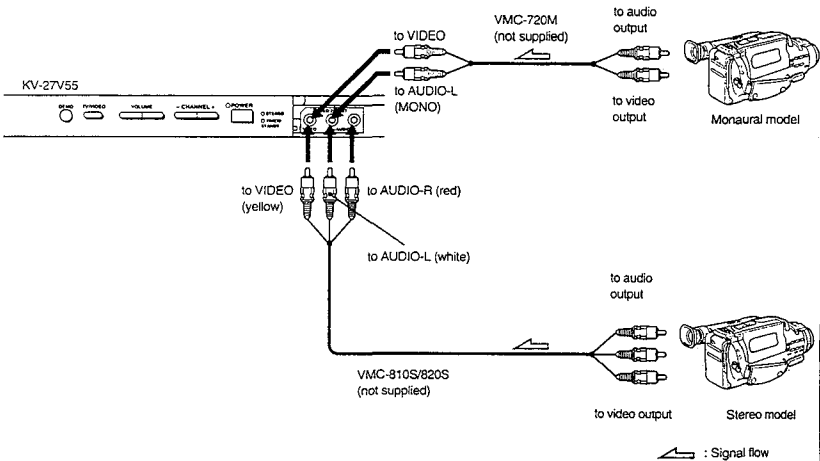

**Preparing for use**

Same as p. 23.

### Connecting on Audio System

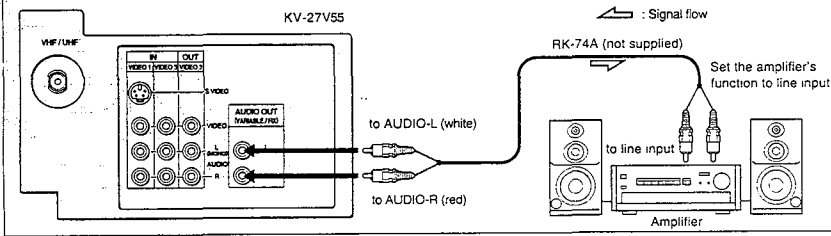

### Preparing for use

Display the mode set menu and set **SPEAKER** to **OFF** to cut off the TV speaker sound (p. 37), and listen to the TV's sound solely through the audio system speakers.

### Note

By setting **AUDIO OUT** variable, you can adjust the bass, treble and balance, or select surround or an MTS (Multichannel TV Sound) mode, using the on-screen menus (pp. 34-36).

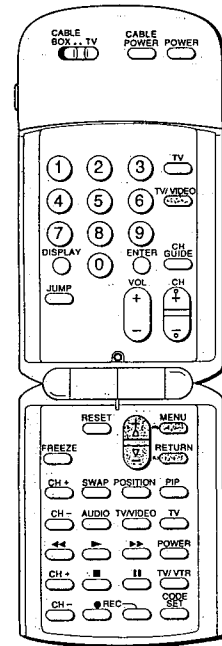

RM-Y119

To return to the normal screen  
Press **MENU**.

### Note

If you set **S VIDEO** to **ON**, the TV automatically receives S video signals whenever a VCR with S video is connected.

### Watching a Video with Your S Video-Equipped VCR

Use this feature to set **S VIDEO** to **ON** or **OFF** depending on the kind of video equipment you have connected to the TV. For instructions on connecting video equipment, see pp. 22-25.

### Note

If the TV is in **TV**, **VIDEO 2** or **VIDEO 3** mode, the **S VIDEO** display appears in black and cannot be selected. Press **TV/VIDEO** to change to **VIDEO 1** mode.

- 1** Press **MENU**.  
The main menu appears.



VIDEO  
AUDIO  
TIME  
SET UP  
CLOSED CAPTION  
Use  $\Delta$   $\nabla$  Exit

- 2** Press  $\Delta$  or  $\nabla$  to select **SET UP**.



VIDEO  
AUDIO  
TIME  
SET UP  
CLOSED CAPTION  
Use  $\Delta$   $\nabla$  Exit

Press **RETURN**.  
The **SET UP** menu appears.



SET UP  
CABLE: ON  
AUTO PROGRAM  
CH ERASE/ADD  
CH CAPTION/GUIDE  
S VIDEO: ON  
VIDEO LABEL  
>MENU

- 3** Press  $\Delta$  or  $\nabla$  to select **S VIDEO**.  
Then press **RETURN**.



SET UP  
CABLE: ON  
AUTO PROGRAM  
CH ERASE/ADD  
CH CAPTION/GUIDE  
S VIDEO: ON  
VIDEO LABEL  
>MENU

Press  $\Delta$  or  $\nabla$  to select **ON** or **OFF** alternately.

SET UP  
CABLE: ON  
AUTO PROGRAM  
CH ERASE/ADD  
CH CAPTION/GUIDE  
S VIDEO: ON  
VIDEO LABEL  
>MENU



SET UP  
CABLE: ON  
AUTO PROGRAM  
CH ERASE/ADD  
CH CAPTION/GUIDE  
S VIDEO: OFF  
VIDEO LABEL  
>MENU

Press **RETURN**.  
The setting is completed.

## 1-6. WATCHING TV PROGRAMS

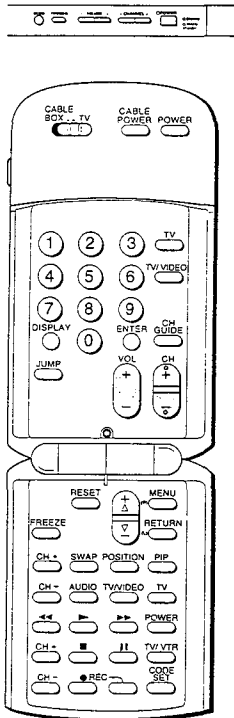

RM-Y119

**1** Press **POWER** on the TV or the Remote Commander to turn the TV on. The **TIMER/STAND BY** indicator blinks until the picture appears.

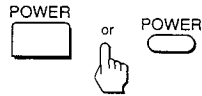

**2** Turn the cable mode on or off to select the type of channel you want to watch, VHF/UHF or cable TV. (Follow the steps in "Turning the Cable Mode On or Off," p. 17.)

If "VIDEO" or "S VIDEO" is displayed on the screen, press the **TV** or **TV/VIDEO** button so that the channel number appears.

**3** Select a channel in one of the following two ways:

To scan the preset channels\* in numerical sequence  
Press **CH +/-**



\* For more information on presetting channels, see pp. 18-21.

To select a channel directly

Press **0-9** and **ENTER**.  
For example, to select channel 14, press **1**, **4** and **ENTER**.



**4** Press **VOL +/-** to adjust the volume.

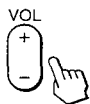

The display will disappear automatically after 3 seconds.

To turn off the TV  
Press **POWER** on the TV or the Remote Commander again.

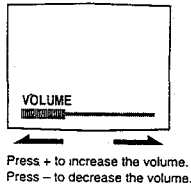

Press **+** to increase the volume.  
Press **-** to decrease the volume.

## 1-7. USING CONVENIENT FEATURES

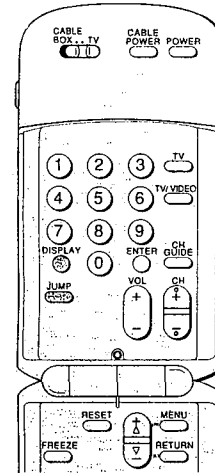
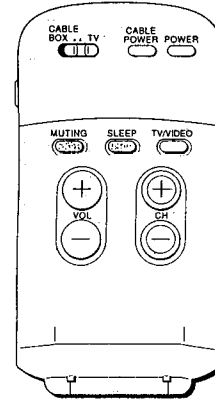

RM-Y119

### Muting the Sound—MUTING

Press **MUTING**.  
The display "MUTING" will appear on the screen.



To restore the sound  
Press **MUTING** again, or press **VOL +**.

### Keeping the Displays On-Screen—DISPLAY

To display the channel  
Press **DISPLAY**.

All the existing displays appear: channel number, channel caption (if set), MTS mode ("SAP" only), window picture input mode and the current time ("AM" or "PM" disappears after about three seconds).



To cancel the display  
Press **DISPLAY** again.  
The channel display will disappear.

### Using the Sleep Timer—SLEEP

The sleep timer turns off the TV automatically after the amount of time you select.

Press **SLEEP**

Each time you press **SLEEP**, the time increments "30", "60", "90" and "OFF" mode appear in sequence.



SLEEP 30
SLEEP 60
SLEEP 90
SLEEP OFF

The **SLEEP** display appears about one minute before the TV turns off.

To cancel the setting

Press **SLEEP** until "OFF" mode appears.  
The "SLEEP OFF" display appears for about three seconds.

OR

Turn the TV off.  
The sleep timer setting is cancelled.

### Switching Quickly Between Two Channels—JUMP

Press **JUMP** once to recall the channel you were watching previously. Press **JUMP** again to switch back. Use this feature to keep track of two programs alternately.



## 1-8. USING CLOSED CAPTION (except for KV-29V55M)

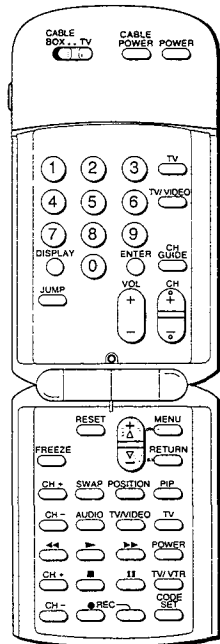

RM-Y119

**1** Press MENU.  
The main menu appears.



```

▶VIDEO
AUDIO
TIME
SET UP
CLOSED CAPTION
Use ⏏ MENU Exit ⏏
    
```

**2** Press Δ+ or ▽- to select CLOSED CAPTION.  
Then press RETURN.  
The CLOSED CAPTION screen appears.



```

CLOSED CAPTION
▶CC/TEXT OFF
CC1
CC2
TEXT1
TEXT2
▶MENU
Use ⏏ MENU Exit ⏏
    
```

**3** Press Δ+ or ▽- to select closed caption mode.



Select CC1 or CC2 to view Captions.  
A Caption is a printed version of the dialogue or sound effects of a program. (The mode should be set to CC1 for most programs.)

```

CLOSED CAPTION
▶CC/TEXT OFF
CC1
CC2
TEXT1
TEXT2
▶MENU
Use ⏏ MENU Exit ⏏
    
```

Select TEXT1 or TEXT2 to view Text.  
Text is information that is presented using the half to full television screen. It is usually not related to the program.

```

CLOSED CAPTION
▶CC/TEXT OFF
CC1
CC2
▶TEXT1
TEXT2
▶MENU
Use ⏏ MENU Exit ⏏
    
```

Select CC/TEXT OFF if you do not want to use the CLOSED CAPTION mode.

```

CLOSED CAPTION
▶CC/TEXT OFF
CC1
CC2
TEXT1
TEXT2
▶MENU
Use ⏏ MENU Exit ⏏
    
```

Press RETURN.  
The setting is completed.



## 1-9. WATCHING TWO PICTURES AT ONCE (PICTURE-IN-PICTURE)

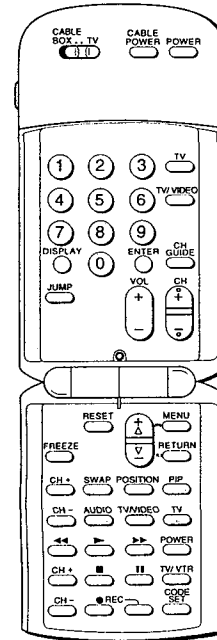

RM-Y119

You can watch both the main picture and a window picture simultaneously by using the Picture-in-Picture (PIP) function.  
In order to enjoy this function, first connect a VCR to the TV.  
Then you can watch a second TV channel through the VCR tuner. (See "Connecting Other Equipment", pp. 22-27.)

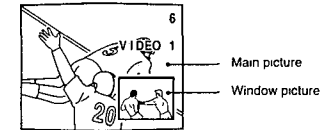

### Picture-in-Picture special features

When watching the main picture and a window picture, you can:

- Swap the main and window pictures (SWAP).
- Change the position of the window picture (POSITION).
- Display a still picture as a window (FREEZE).
- Choose the sound from the main or window picture (AUDIO).

### Displaying a window picture—PIP

Press PIP to display a window picture.



Input-source mode or TV channel for the main picture

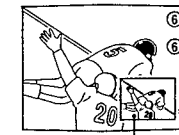

Input-source mode or TV channel for the window picture

Press PIP again to display a smaller window picture.



To disappear the window picture  
Press PIP once more.

### Note

To operate your VCR with the supplied Remote Commander, See "Using the Pre-Programmed Remote Commander", pp. 55-57.

### Changing the window picture input mode

**1** Press PIP to display a window picture.

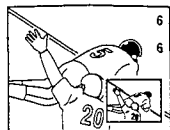

**2** Press TV/VIDEO in the Picture-in-Picture control area to select the input mode.

Each time you press TV/VIDEO, "TV" "VIDEO 1", "VIDEO 2" and "VIDEO 3" appear in sequence.

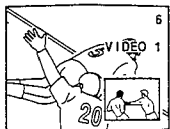

Press TV in the Picture-in-Picture control area to return to TV mode directly.

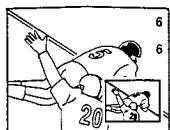

A window picture will appear in the same input mode as the last time you used PIP

### To receive the window picture sound

Press AUDIO.  
The  display appears for a few seconds, indicating that the window picture sound is being received.



To restore the main picture sound  
Press AUDIO again.

### Notes

- If the main picture is not receiving an image, the window picture may be in black and white.
- When you turn PIP on or when you turn the TV on with PIP mode, the window picture will appear at the bottom right of the screen.
- The window picture may be affected by the condition of the main picture.
- The window picture sound is also output from the VARIABLE/FIX AUDIO OUT jacks.

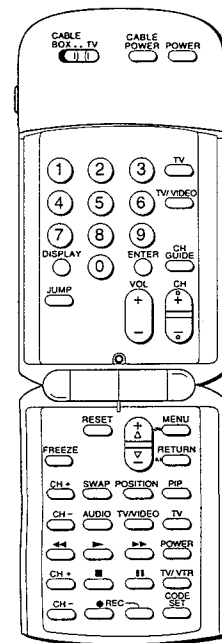

RM-Y119

### Changing TV channels in the window picture

**1** Press PIP to display a window picture.

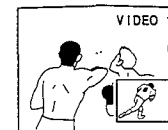

**2** Press CH +/- in the PIP control area.

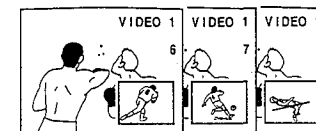
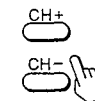

### Changing the position of the window picture—POSITION

**1** Press PIP to display a window picture.



**2** Press POSITION.  
Each time you press POSITION, the window picture will move counterclockwise on the screen, as illustrated below.

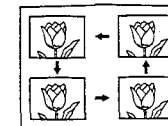

### Displaying a still picture — FREEZE

Use the FREEZE function to display a still picture as a window. This function is useful when you want to write down a recipe from a cooking program, a displayed address or a phone number and so on.

- 1 Press PIP to display a window picture.

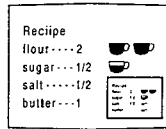

- 2 Press FREEZE. The window picture image remains still on the screen.

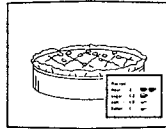

To restore the normal picture Press FREEZE again.

### Swapping the main and window pictures — SWAP

- 1 Press PIP to display a window picture.

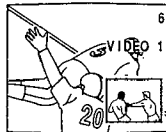

- 2 Press SWAP. Each time you press SWAP, the images from the main and window pictures switch places.

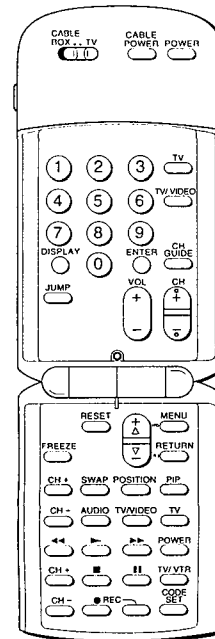
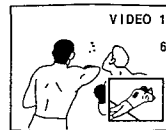

RM-Y119

### Displaying a pay cable TV channel as a window picture

To display a pay cable TV channel as a window picture, connect your decoder box as illustrated below.

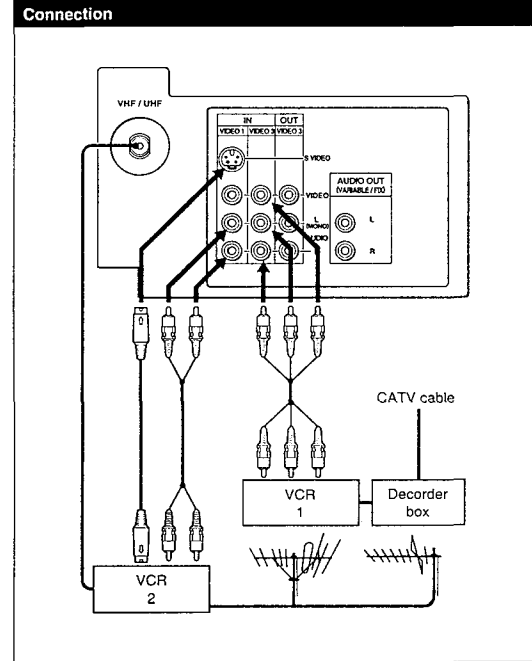

After making the connections, turn the cable mode on by following the steps "Turning the Cable Mode On or Off", p. 17. Then continue with steps below.

- 1 Press PIP to display a window picture.

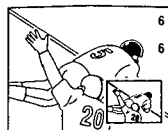

- 2 Press TV/VIDEO in the Picture-in-Picture control area to select the input mode.  
Each time you press TV/VIDEO, "TV", "VIDEO 1", "VIDEO 2" and "VIDEO 3" appear in sequence.

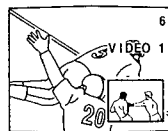

- 3 Put your VCR on an inactive channel (CH 3 or 4).

- 4 Change pay cable TV channels with the decoder box.

## 1-10. USING THE TIMER-ACTIVATED FUNCTIONS

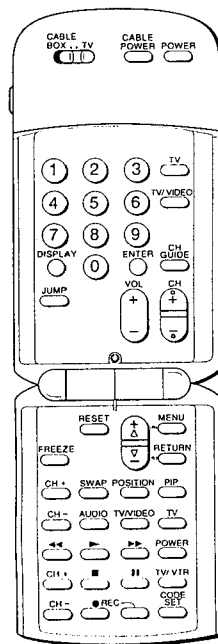

RM-Y119

### Setting the Clock—CURRENT TIME SET

Follow these instructions to set the current time. The correct time must be set in order to use the timer-activated functions (ON/OFF TIMER, CHANNEL BLOCK).

EXAMPLE: Set the time to 3:15 PM, Monday.

- 1 Press MENU.  
The main menu appears.



VIDEO  
AUDIO  
TIME  
SET UP  
CLOSED CAPTION

Use Exit

- 2 Press  $\Delta$  or  $\nabla$  to select TIME.



VIDEO  
AUDIO  
▶ TIME  
SET UP  
CLOSED CAPTION

Use Exit

Press RETURN.  
The TIME menu appears, and the cursor points to "CURRENT TIME SET"



TIME  
▶ CURRENT TIME SET  
ON/OFF TIMER  
CHANNEL BLOCK  
▶ MENU

Use M Exit

- 3 Press RETURN.  
The CURRENT TIME SET screen appears.



CURRENT TIME SET  
▶ --- : -- : -- M

Use Exit

- 4 Press RETURN again.  
"Set the day." appears on the screen.



CURRENT TIME SET  
SUN 12:00 M  
▶ MENU

Set the day.  
Use Exit

**5** Press  $\Delta+$  or  $\nabla-$  to set the day.  
Each time you press  $\Delta+$  or  $\nabla-$ , the day changes consecutively.



Press RETURN.  
"Set the time." appears on the screen.

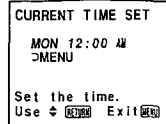

**To reset the time**  
Press RESET while in the CURRENT TIME screen, and repeat steps 4-7.

**To display the time**  
Press DISPLAY.

**To return to the normal screen**  
Press MENU.

**Notes**

- The internal clock of this TV operates on a 12-hour cycle. If a 24-hour cycle number (for instance, 13:00) is entered, it will be cleared when you press RETURN.

12:00 AM stands for midnight.  
12:00 PM stands for noon.

- All the settings including CURRENT TIME SET will be erased if you unplug the TV or a power failure occurs. Reset the current time by following steps 1-7.

**6** Press  $\Delta+$  or  $\nabla-$  to set the hour.  
Each time you press  $\Delta+$  or  $\nabla-$ , the hour changes starting with "12:00 AM."



Press RETURN.

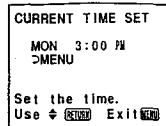

**7** Press  $\Delta+$  or  $\nabla-$  to set the minutes.  
Each time you press  $\Delta+$  or  $\nabla-$ , the minutes change in sequence.



Press RETURN.  
The setting is completed, and the clock starts.

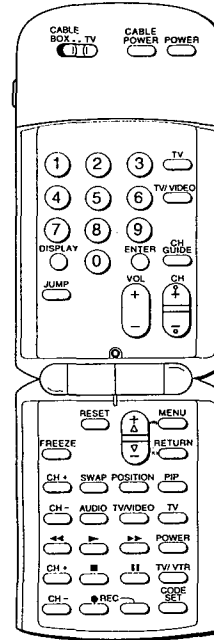
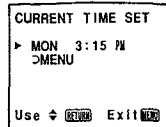
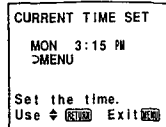

RM-Y119

**Setting the ON/OFF TIMER**

With this function you can set your favorite program to appear on the screen at the time that you set.

EXAMPLE: Set the timer to turn on the TV every Monday through Friday at 3:15 PM for 2 hours, on channel 21.

**1** Press MENU.  
The main menu appears.

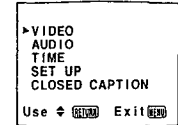

**2** Press  $\Delta+$  or  $\nabla-$  to select TIME.  
Then press RETURN.  
The TIME menu appears.



**3** Press  $\Delta+$  or  $\nabla-$  to select ON/OFF TIMER.  
Then press RETURN.  
The ON/OFF TIMER screen appears.



**Note**

If the ON/OFF TIMER display appears in black, the current time has not been set and you cannot select ON/OFF TIMER. To set the clock, see "Setting the Clock—CURRENT TIME SET", pp. 44-45.

**4** Press RETURN again.  
"Set the day." appears on the screen.





## 1-11. CUSTOMIZING THE SCREEN DISPLAY

- 5** Press  $\Delta+$  or  $\nabla-$  to set the day.  
Each time you press  $\Delta+$  or  $\nabla-$ , the days of the week change as shown in Fig. 1. (See p. 47.)

Then press RETURN.  
"Set the time." appears on the screen.

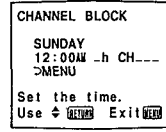

If you select a channel which has been blocked, the message of "BLOCKED" appears.



- 6** Press  $\Delta+$  or  $\nabla-$  to set the hour.  
Each time you press  $\Delta+$  or  $\nabla-$ , the hour changes in sequence.  
Then press RETURN.

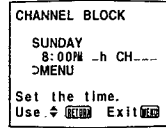

To clear the BLOCK setting  
Press RESET while in the CHANNEL BLOCK screen.

To return to the normal screen  
Press MENU.

### Notes

- If you set a new CHANNEL BLOCK by following steps 1-9, the original setting will be erased.
- If you have not set the clock correctly, CHANNEL BLOCK will not operate at the proper time. To set the clock, see "Setting the Clock—CURRENT TIME SET", pp. 44-45.

- 7** Press  $\Delta+$  or  $\nabla-$  to set the minutes.  
Each time you press  $\Delta+$  or  $\nabla-$ , the minutes change in sequence.  
Then press RETURN.

"Set the duration." appears on the screen.

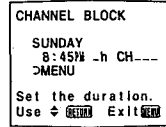

- 8** Press  $\Delta+$  or  $\nabla-$  to set the duration of time that you want the TV remain blocked.  
Each time you press  $\Delta+$  or  $\nabla-$ , the duration changes from 1 to 6 in sequence.  
Then press RETURN.

"Select the channel" appears on the screen.

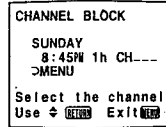

- 9** Press  $\Delta+$  or  $\nabla-$  to set the channel that you want to block.  
Each time you press  $\Delta+$  or  $\nabla-$ , the channel number changes from 1 to 125 in sequence.



Press RETURN.  
The setting is completed.

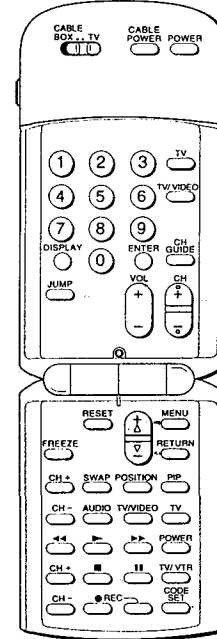
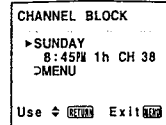
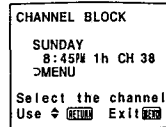

RM-Y119

### Setting Channel Captions—CH CAPTION

Use this feature to caption up to 12 channel number displays with the matching channel call letters.

EXAMPLE: Caption channel 20 with ESPN at the caption position number 4.

- 1** Press MENU.  
The main menu appears.

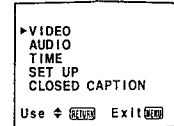

- 2** Press  $\Delta+$  or  $\nabla-$  to select SET UP.  
Then press RETURN.  
The SET UP menu appears.

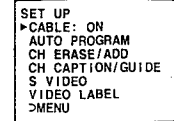
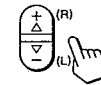

- 3** Press  $\Delta+$  or  $\nabla-$  to select CH CAPTION/GUIDE.  
Then press RETURN.  
The CH CAPTION/GUIDE screen appears.

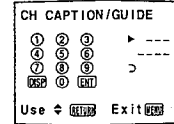
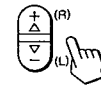

### Note

If the CH CAPTION display appears in black, the TV is in video mode and you cannot select CH CAPTION/GUIDE. Press TV or TV/VIDEO to change to TV mode.

- 4** Press RETURN again.  
"Select a position." appears on the screen.

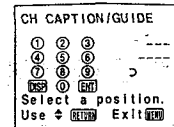

- 5** Press  $\Delta$  or  $\nabla$  to select a caption position number.  
Each time you press  $\Delta$  or  $\nabla$ , the caption position number is marked in sequence.  
Then press RETURN.  
"Select the channel" appears on the screen.

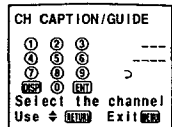

To erase unneeded captions  
Call the caption setting screen by following  
steps 1-5, and press RESET.  
To return to the normal screen  
Press MENU.

- 6** Press  $\Delta$  or  $\nabla$  to select the channel you want to caption.  
Each time you press  $\Delta$  or  $\nabla$ , the channel number changes from 1 to 125.  
Then press RETURN.  
"Select the letter." appears on the screen.

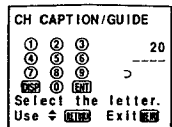

- 7** Press  $\Delta$  or  $\nabla$  to select the first letter.  
Each time you press  $\Delta$  or  $\nabla$ , "0-9", "A-Z", "&", "!", "-" and " (blank space)" appear  
in sequence.

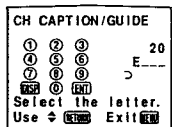
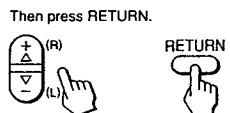

- 8** Repeat step 7 to select each remaining letter.  
(For a 3-letter caption, leave a space by pressing RETURN only.)

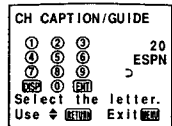

- 9** Press RETURN.  
The setting is completed.

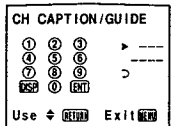

To caption other channels  
Repeat steps 4-9.

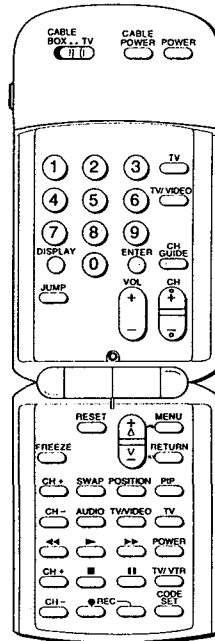

RM-Y119

### Viewing the Captioned Channels—CH GUIDE

Use this feature to display the captions you set, and to select a channel directory for viewing.

- 1** Press CH GUIDE.  
A directory appears, corresponding to the directory keys on the Remote Commander.

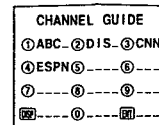
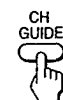

To cancel the CHANNEL GUIDE screen  
Press CH GUIDE again.

- 2** Press the directory key of the channel you want to watch.

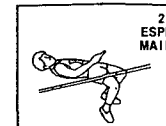

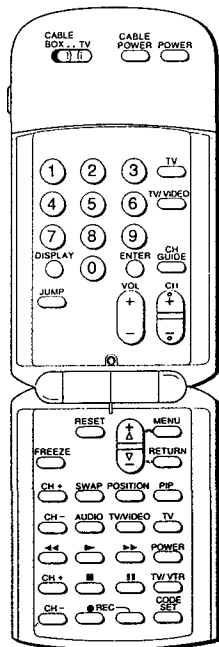

RM-Y119

**Setting VIDEO LABEL**

Use this feature to label each input mode in order to identify the equipment connected to each input terminal.

EXAMPLE: Label VIDEO 1 IN as VHS.

**1** Press MENU.  
*The main menu appears.*



▶VIDEO  
AUDIO  
TIME  
SET UP  
CLOSED CAPTION  
Use ◀ RETURN Exit ▶

**2** Press Δ+ or ∇- to select SET UP



VIDEO  
AUDIO  
TIME  
▶SET UP  
CLOSED CAPTION  
Use ◀ RETURN Exit ▶

Press RETURN.  
*The SET UP menu appears.*



SET UP  
▶CABLE: ON  
AUTO PROGRAM  
CH ERASE/ADD  
CH CAPTION/GUIDE  
S VIDEO: ON  
VIDEO LABEL  
>MENU

**3** Press Δ+ or ∇- to select VIDEO LABEL.



SET UP  
CABLE: ON  
AUTO PROGRAM  
CH ERASE/ADD  
CH CAPTION/GUIDE  
S VIDEO: ON  
▶VIDEO LABEL  
>MENU

Press RETURN.  
*The VIDEO LABEL screen appears.*



VIDEO LABEL  
▶VIDEO1: VIDEO1  
VIDEO2: VIDEO2  
VIDEO3: VIDEO3  
>MENU  
Use ◀ RETURN Exit ▶

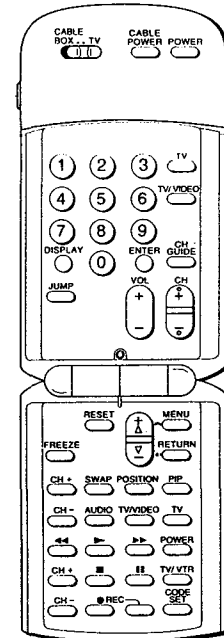

RM-Y119

**4** Press Δ+ or ∇- to select the input mode you want to label.



Press RETURN.



VIDEO LABEL  
▶VIDEO1: VIDEO1  
VIDEO2: VIDEO2  
VIDEO3: VIDEO3  
>MENU  
Use ◀ RETURN Exit ▶

**5** Press Δ+ or ∇- to select VHS.



*Each time you press Δ+, the label changes:*

VIDEO 1  
VIDEO 1 → S VIDEO → BETA → 8 mm → VHS → LD

VIDEO 2  
VIDEO 2 → BETA → 8 mm → VHS → LD

VIDEO 3  
VIDEO 3 → BETA → 8 mm → VHS → LD

(∇-: reverse order)

Press RETURN.



VIDEO LABEL  
VIDEO1: VIDEO1  
VIDEO2: VIDEO2  
VIDEO3: VIDEO3  
>MENU  
Use ◀ RETURN Exit ▶

VIDEO LABEL  
▶VIDEO1: VHS  
VIDEO2: VIDEO2  
VIDEO3: VIDEO3  
>MENU  
Use ◀ RETURN Exit ▶

To label other input modes  
Repeat steps 4-5.

To return to the normal screen  
Press MENU.

## 1-12. USING THE PRE-PROGRAMMED REMOTE COMMANDER

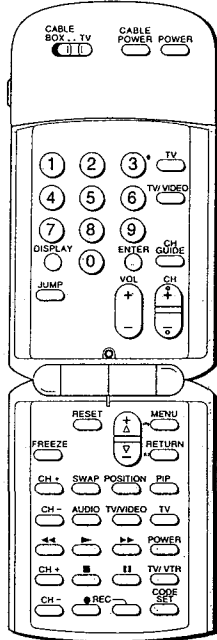

RM-Y119

You can operate your video equipment and cable converter box that has an infrared remote detector with this supplied pre-programmed Remote Commander.

### Operating Sony or Non-Sony Video Equipment—Pre-Programmed Function

With the supplied Remote Commander, you can operate a Sony video cassette recorder (Beta, 8 mm, VHS) or a multi disc player as well as most non-Sony video equipment connected to your TV by following the steps below.

- 1 While pressing CODE SET, press 0 - 9 to enter the manufacturer's code number (see chart on p. 56). For example, to operate a Sony 8 mm VCR, press 0, 2 and ENTER.

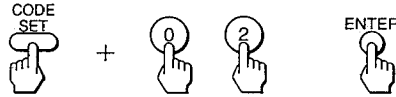

- 2 Use the video operating buttons on the Remote Commander to operate the video equipment.

#### Operating a VCR

To turn on or off

Press (VIDEO) POWER.

To change channels (when watching TV programs through the VCR's tuner)

Press CH +/-

To record

Press ● (2 buttons simultaneously).

To play

Press ►

To stop

Press ■.

To fast forward

Press ►►

To rewind the tape

Press ◄◄.

To pause

Press II.

To search the picture forward and backward

Press ►► or ◄◄ during playback.

#### Operating a Video Disc Player

To play

Press ►

To stop

Press ■.

To pause

Press II.

To resume normal playback, press again.

\* This function is effective only for CAV (standard-play disc). With CLV (extended-play disc), the TV will go into the standby mode if II is pressed.

To search the picture forward and backward

Keep pressing ►► or ◄◄ during playback. To resume normal playback, release the button.

### Manufactures and Code Numbers (VCR/video disc player)

Manufacturer	Code number
SONY	01, 02, 03, 04
CANON	05
EMERSON	22, 30, 33
FISHER	10, 11, 12, 15
FUNAI	29
GENERAL ELECTRIC	05, 08
GOLDSTAR	25
HITACHI	07, 08
JVC	16
MAGNAVOX	05, 06, 09
MITSUBISHI	18, 19, 26, 27
MULTITECH	29
NEC	16, 23, 31
PANASONIC	05, 06
PHILCO	05, 06
PHILIPS	05, 06, 09
QUASAR	05, 06
RCA	07, 08
SAMSUNG	24, 32
SANYO	11, 15
SCOTT	21
SHARP	13, 14
SHINTOM	34
SYLVANIA	05, 06, 09
SYMPHONIC	29
TEKNIKA	28, 29
TOSHIBA	20, 21
TOTE VISION	25
ZENITH	17

The code numbers for Sony equipment are assigned as follows:

- 01 ..... Beta, ED Beta VCR
- 02 ..... 8 mm VCR
- 03 ..... VHS VCR
- 04 ..... Video disc player

### Notes

- If more than one code number is listed for manufacturers other than Sony, try entering them one by one, until you come to the correct code for your equipment.
- If the video equipment does not have a certain function, the corresponding button on this Remote Commander will not operate.
- In some rare cases, you may not be able to operate your non-Sony video equipment with the supplied Remote Commander. This is because your equipment may use a code that is not provided with this Remote Commander. In this case, please use the equipment's own remote control unit.

### CAUTION

When you remove the batteries from the Remote Commander, all the settings will revert to the Sony Beta setting. Reset the codes by following the steps on p. 55.

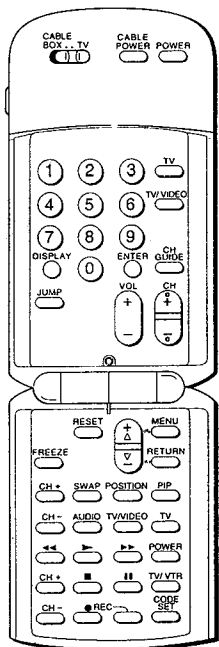

RM-Y119

**Operating a Cable Converter Box**

Follow these instructions to set the manufacturer's code which will enable you to operate a connected cable converter box with the pre-programmed Remote Commander.

EXAMPLE: Operate a connected Zenith cable converter box.

**1** Set the CABLEBOX-TV selector to CABLEBOX.



**Notes**

- If more than one code number is listed, try entering them one by one until you come to the correct code for your equipment.
- If you enter a new code number, the code number you previously entered at that setting is erased.
- In some rare cases, your equipment may use a code that is not provided with this Remote Commander and you may not be able to operate your cable converter box with the supplied Remote Commander. In this case, use the equipment's own remote control unit.

**2** While pressing CODE SET, press 6 and 8 (Zenith's code number -see chart below) and ENTER.

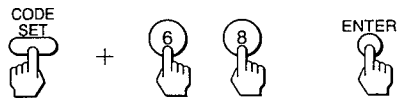

A long beep sounds, indicating that the code has been set.

**Manufactures and Code Numbers (cable box)**

Manufacturer	Code number
JERROLD	60, 61, 62, 63, 64, 65
PIONEER	69, 70
SCIENTIFIC ATLANTA	66, 67
TOCOM	71, 72
ZENITH	68

**Note**

If you press a wrong code or if the code has not been set, four short beeps sound. Repeat step 2 to set the code.

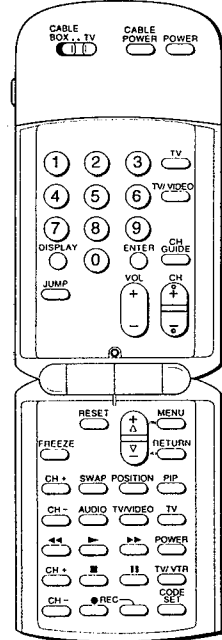

RM-Y119

**3** Use CABLE POWER and the TV control buttons (0 - 9, ENTER, JUMP and CH +/-) to operate the cable converter box.

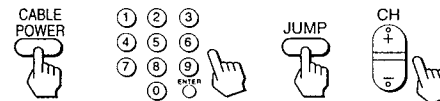

**To operate the TV**

Set the CABLEBOX-TV selector to TV, then use the TV control buttons to control the TV.

For more details on operating the cable box refer to the operating instructions that come with the cable box.

## SECTION 2 DISASSEMBLY

### 2-1. REAR COVER REMOVAL

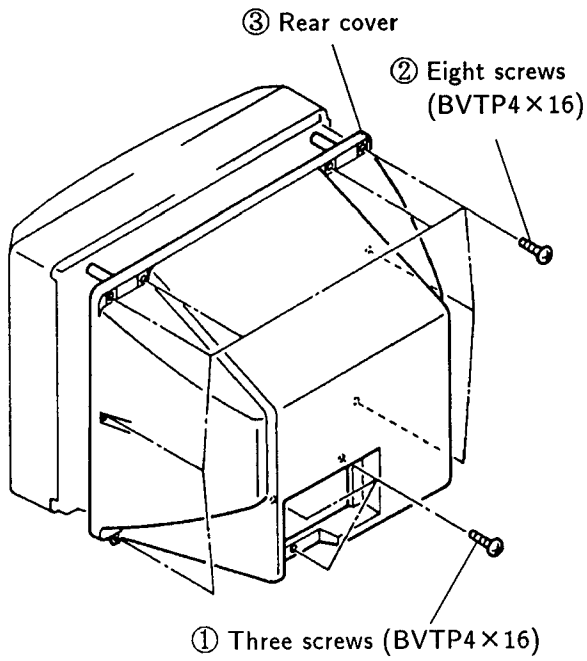

### 2-2. SPEAKER REMOVAL

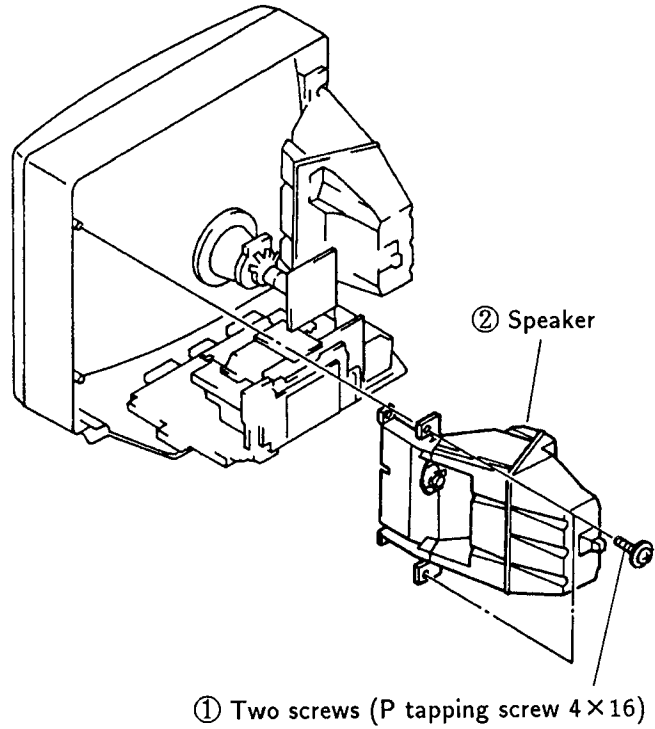

### 2-3. CHASSIS ASSY REMOVAL

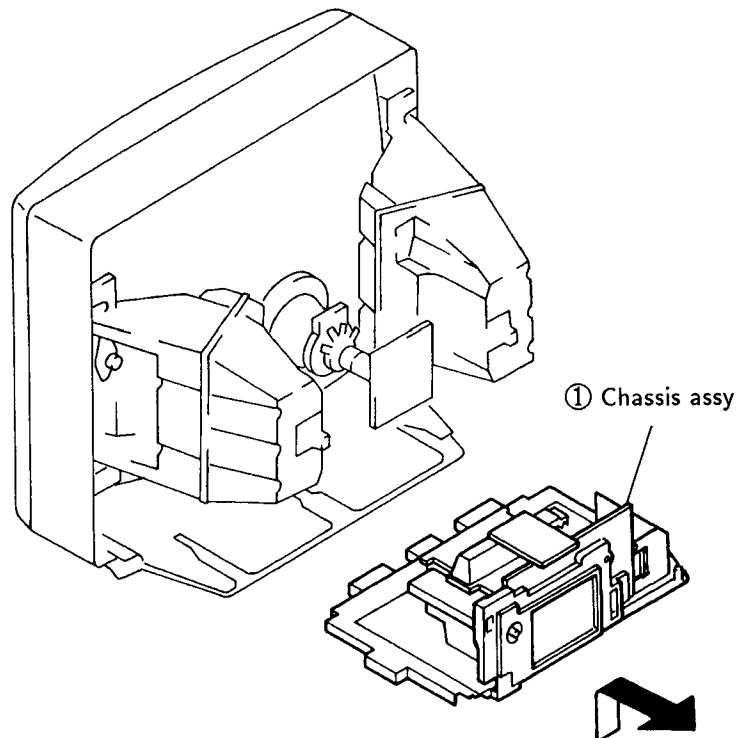

## 2-4. SERVICE POSITION

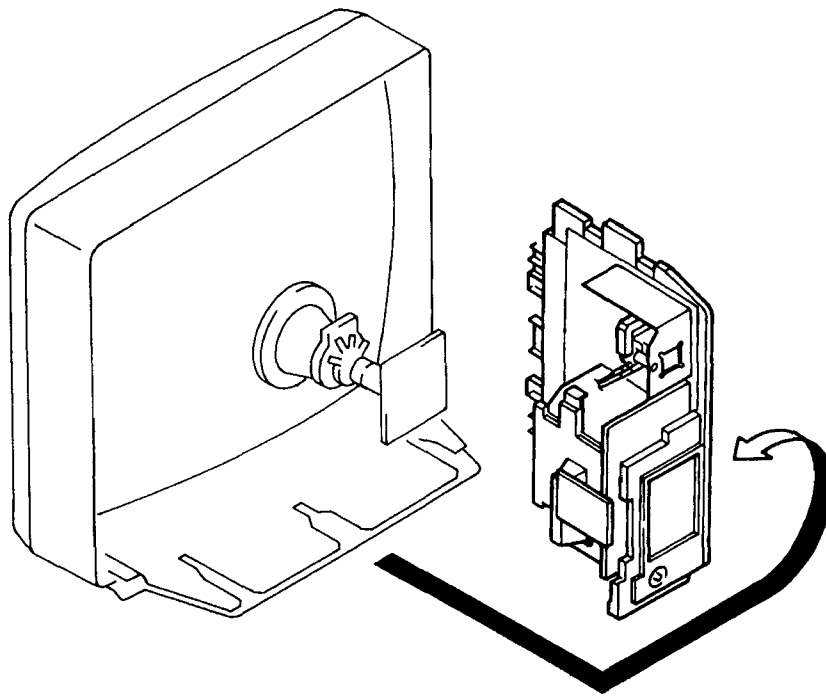

## 2-5. P BOARD AND P BRACKET REMOVAL

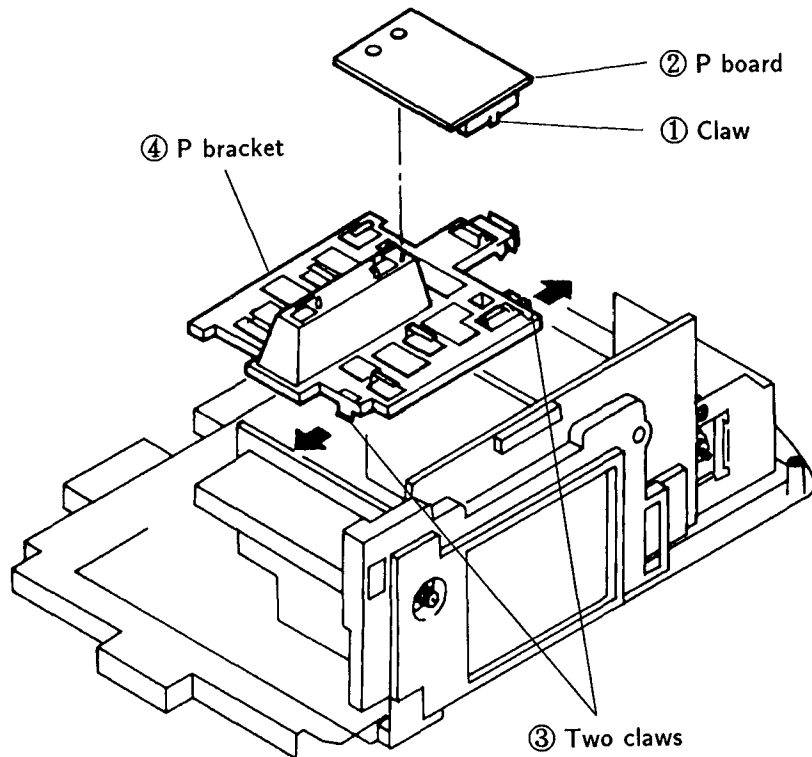

## 2-6. UA BOARD REMOVAL

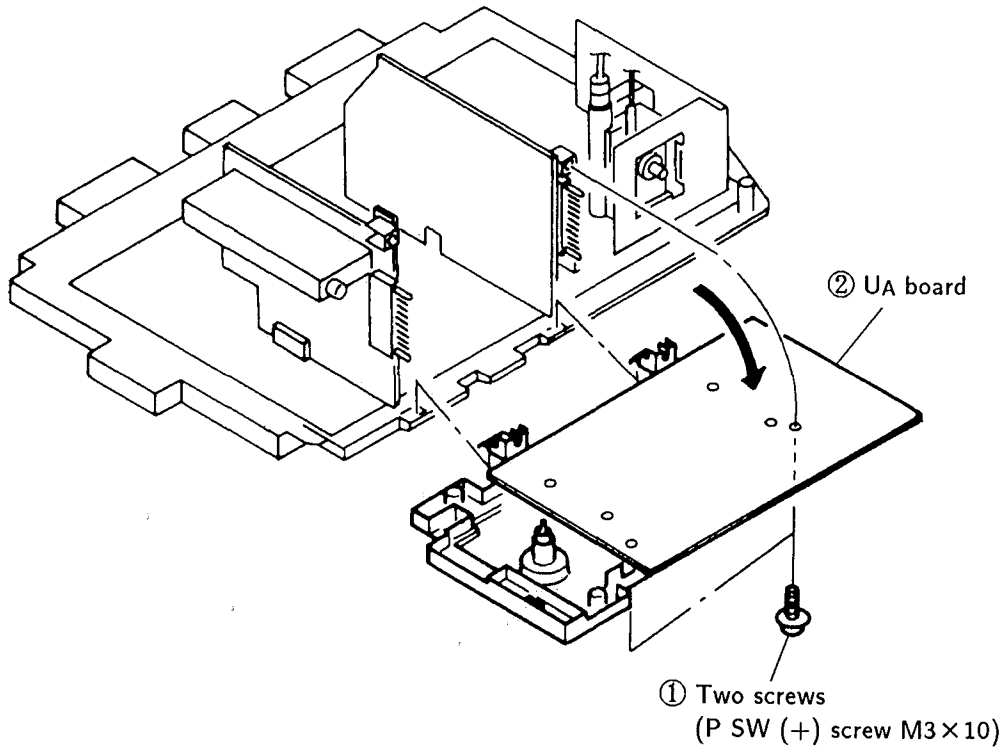

## 2-7. EXTENSION CABLE

※ Connect the connector to solder side.

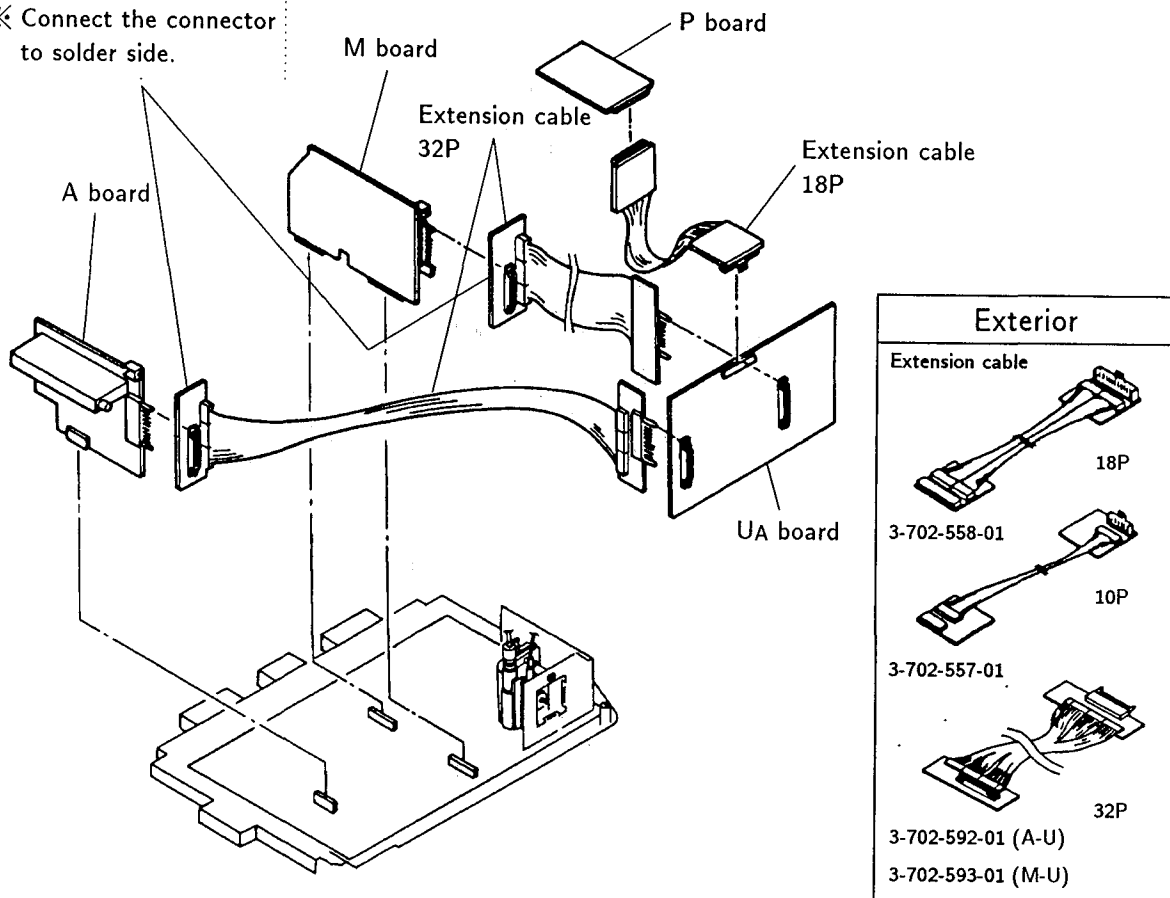

## 2-8. PICTURE TUBE REMOVAL

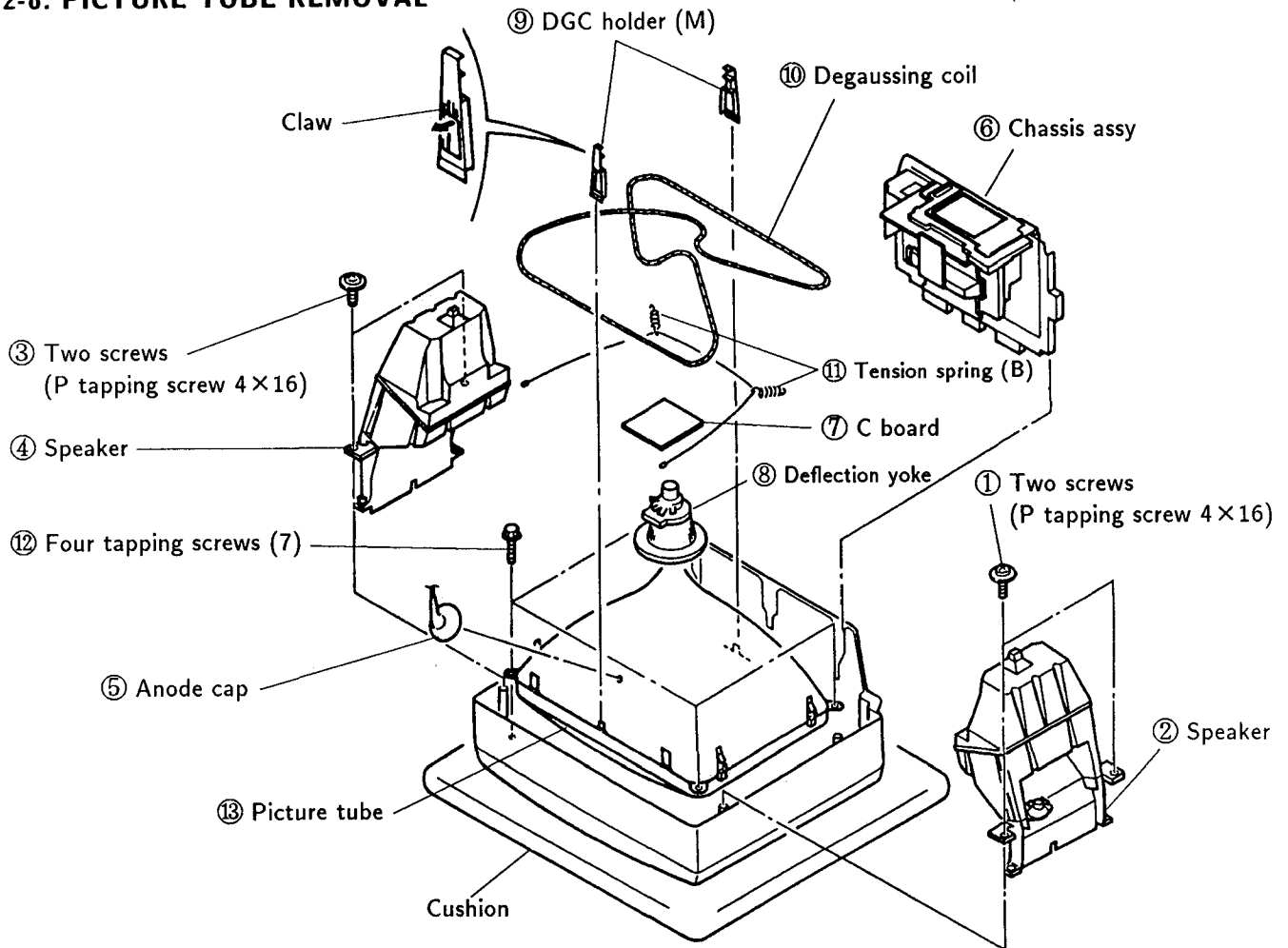

### • REMOVAL OF ANODE-CAP

NOTE : Short circuit the anode of the picture tube and the anode cap to the metal chassis, CRT shield or carbon painted on the CRT, after removing the anode.

### • REMOVING PROCEDURES

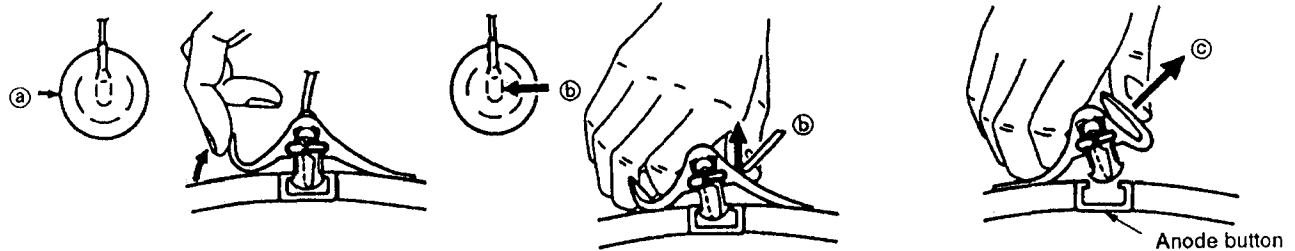

① Turn up one side of the rubber cap in the direction indicated by the arrow ①.

② Using a thumb pull up the rubber cap firmly in the direction indicated by the arrow ②.

③ When one side of the rubber cap is separated from the anode button, the anode-cap can be removed by turning up the rubber cap and pulling up it in the direction of the arrow ③.

### • HOW TO HANDLE AN ANODE-CAP

- ① Don't hurt the surface of anode-caps with sharp shaped material!
- ② Don't press the rubber hardly not to hurt inside of anode-caps!  
A material fitting called as shatter-hook terminal is built in the rubber.
- ③ Don't turn the foot of rubber over hardly!  
The shatter-hook terminal will stick out or hurt the rubber.

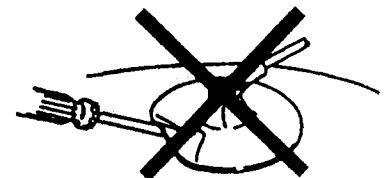
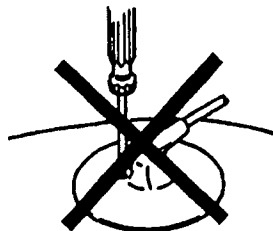

## 2-9. REPAIR OF CHIP COMPONENT CIRCUIT BOARD

### 2-9-1. POINTS OF COMPONENT REMOVAL

#### Handing of blower type soldering iron

If hot blast is too strong or applied from a slanting direction, small components and solder near the component being removed can be blown off. Do not use blower type without temperature control.

### 2-9-2. NOTES ON SOLDERING FOR CHIP COMPONENTS

- 1) During soldering a chip component, if a soldering iron is applied for a long time, the heat may damage the component or cause pattern peeling.
- 2) Do not reuse a removed component. The characteristics of such a component may deteriorate.
- 3) Use wire solder containing silver ( $\phi$  0.3 or  $\phi$  0.6). (The pin electrodes of the laminated chip capacitor are silver +palladium, so if wire solder which does not contain silver is used, the silver of the pin electrode will be sucked into the solder.)

### 2-9-3. REMOVAL AND MOUNTING OF COMPONENTS

#### Chip resistor and chip capacitor

#### REMOVAL

- Using two soldering irons

#### 1) Mounted state

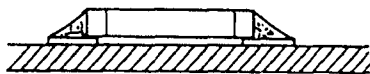

#### 2) Melt the solder.

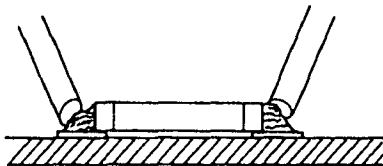

#### 3) Remove the component.

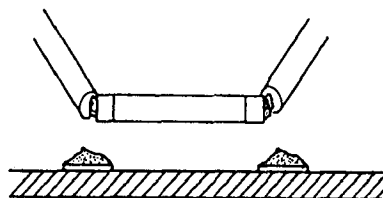

#### SOLDERING

#### 1) Preparation

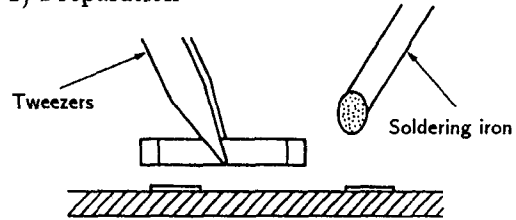

#### 2) Location

Be careful not to misposition.

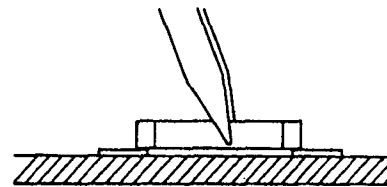

#### 3) Tack soldering and flux application

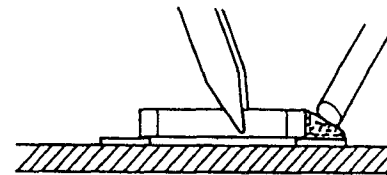

#### 4) Soldering

Apply the soldering iron to the chip component and land to heat them and apply solder.

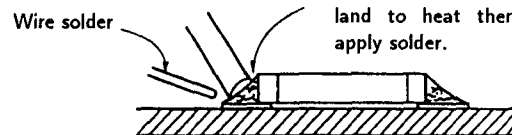

#### 5) Soldering (Fix the fillet.)

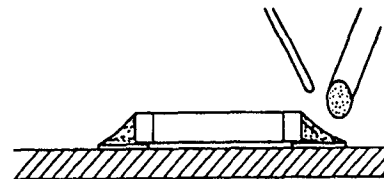

#### 6) Visual inspection

Check for the following defects :

- No-soldered part
- Bridge (to other components or lands)
- Mispositioning
- Other defects

## 2-9-4. MINI-TRANSISTOR

## REMOVAL

- Using two soldering irons

1) Put a little solder on the tip of two soldering irons.

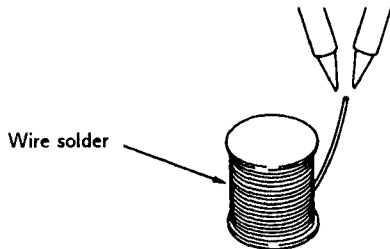

2) Apply the tip of one soldering iron to the point "a" and the other to the points "b" → "c" (or "b" → "d" → "c") and move the component in the directions indicated by arrows in the figure to remove it.

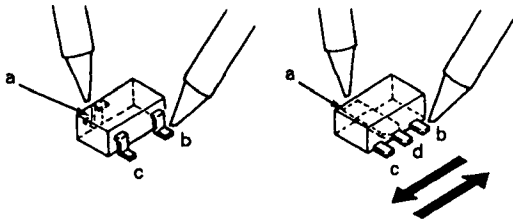

## MOUNTING

1) Apply a little flux to the land with a brush.



2) Place the component in position using tweezers.

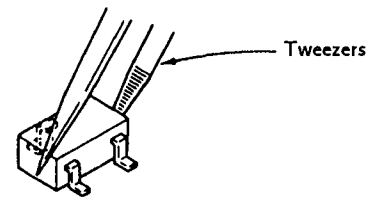

3) Put a little solder on the tip of the soldering iron and solder the point "a" to fix the component.

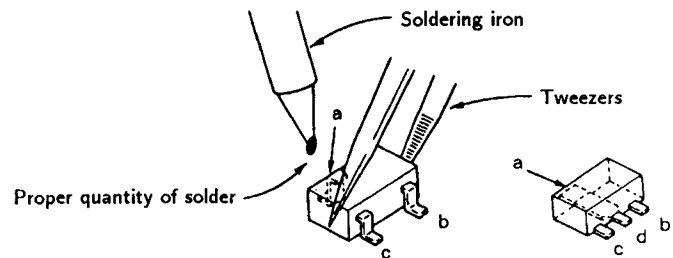

4) Bring the tip of the soldering iron and the wire solder close to the point to be soldered. Solder the points "b" → "c" (or "b" → "d" → "c") in order.

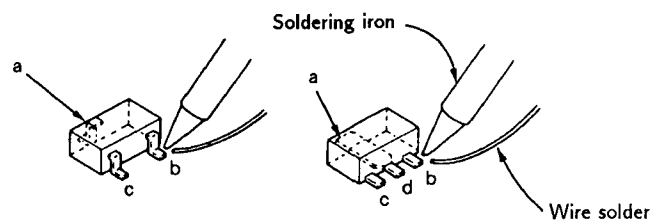

**2-9-5. TWO-DIRECTIONAL FLAT PACKAGE IC**

**MOUNT CONDITION**

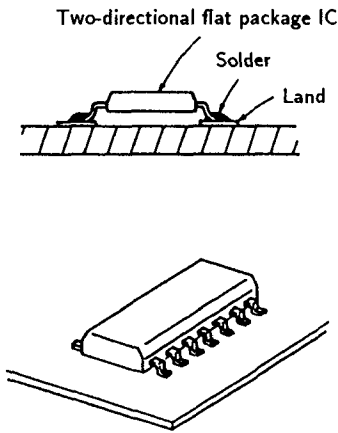

- 3) When the solder melts, lift the IC with a pair of tweezers and remove.

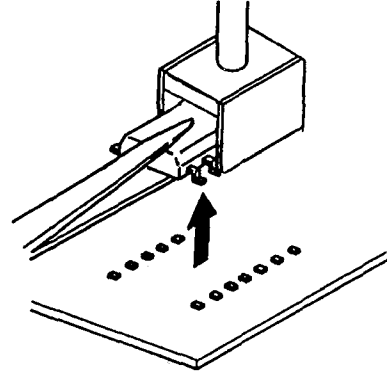

**REMOVAL**

- 1) Apply some solder on the inside and the tip of the iron tip jig.

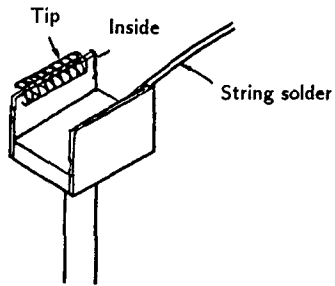

**INSTALLATION**

- 1) Place the two-directional flat package IC at the appointed position, solder pins a and b on the diagonal, and fasten it.

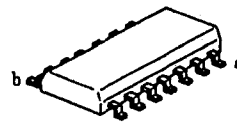

- 2) Place the iron tip jig over the IC, and move the jig to and fro as shown in the figure.

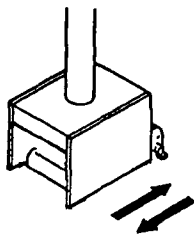

- 2) Solder the remaining pins with the soldering iron.

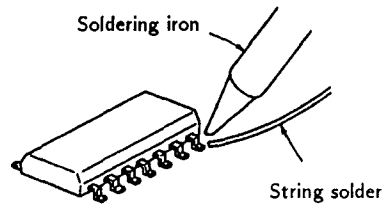

2-9-6. FOUR-DIRECTIONAL FLAT PACKAGE IC

**MOUNT CONDITION**

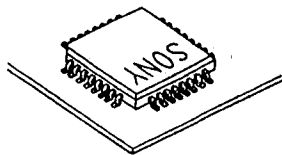
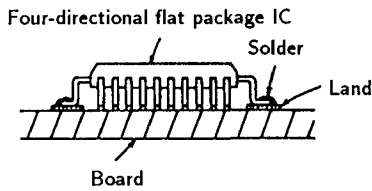

**REMOVAL**

1) Apply solder on the tip of the iron tip jig.

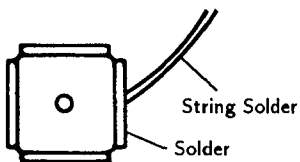

2) Place the iron tip jig over the IC, wait about two to three seconds, rotate the iron slightly and lift it up.

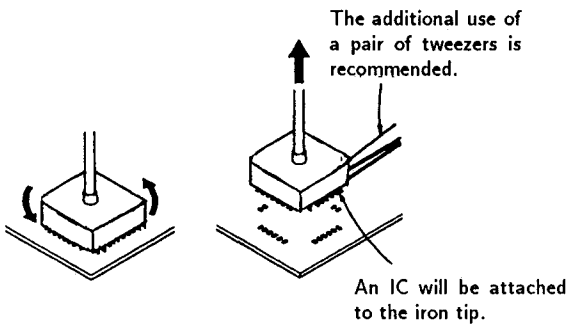

Note: For flat ICs of above 52P, the IC may not be completely attracted when the iron tip jig is lifted up. In these cases, use a pair of tweezers to remove.

**INSTALLATION**

1) Place the four-directional flat package IC at the appointed position.



2) Apply a slight amount of solder on the iron tip, and solder the three sections in the order of a → b → c, and fix.

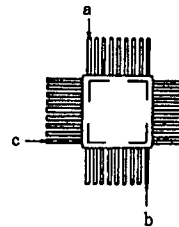

3) Apply a slight amount of flux with a pen on all four directions.

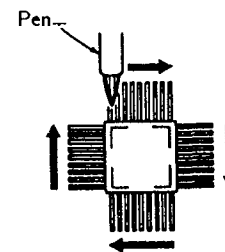

4) Apply solder on the iron tip and the string solder, and slide and solder in the directions of the arrows.

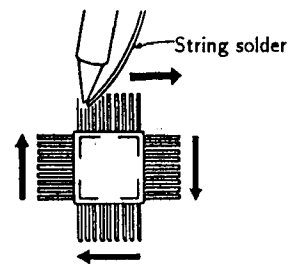

Note: 1) After soldering, if there are bridged sections, correct by sliding the soldering iron in the direction of the arrow.

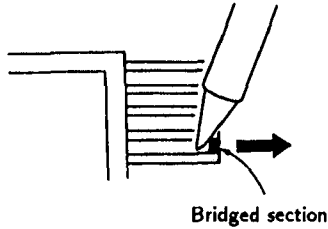

If the bridges cannot be corrected using the above method, apply some flux with a pen and try again.

2) Soldering can be carried out more easily by sliding the iron tip near the tip of the IC leg. (Fig. A)

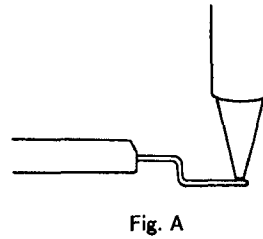

Be careful not to slide the bent sections of the leg as shown in Fig. B as soldering bridges will be formed.

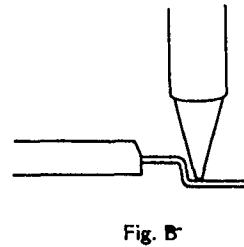

Exterior	Description	Part No.	Measure (mm)			
			A	B	C	D
	jig for removing 4-sided flat package IC	3-702-554-01	12.5	9.5	12.5	9.5
		" 11	15.5	12.5	15.5	12.5
		" 21	16.3	13.3	16.3	13.3
		" 31	17.0	14.0	17.0	14.0
		" 41	23.0	20.0	17.0	14.0
		" 51	20.0	17.0	20.0	17.0
	jig for removing 2-sided flat package IC	3-702-555-01	6.0	5.0	/	
		" 11	6.0	10.0		
		" 21	7.0	12.5		
		" 31	9.0	15.2		
		" 41	9.0	18.0		
	soldering iron	3-702-552-01	55W 60g length 210mm			
	soldering holder	3-702-553-01	/			

## SECTION 3 SET-UP ADJUSTMENTS

- The following adjustments should be made when a complete realignment is required or a new picture tube is installed.
- These adjustments should be performed with rated power supply voltage unless otherwise noted.

Perform the adjustments in order as follows :

1. Beam Landing
2. Convergence
3. Focus
4. White Balance

**Note :** Test Equipment Required.

1. Color-bar/Pattern Generator
2. Degausser
3. Oscilloscope

Controls and switch should be set as follows unless otherwise noted :

PICTURE control . . . . . RESET  
BRIGHTNESS control . . . . . center

**Preparations :**

- In order to reduce the influence of geomagnetism on the set's picture tube face it east or west.
- Switch on the set's power and degauss with the degausser.

**3-1. BEAM LANDING**

1. Input the white signal with the pattern generator.  

Contrast	}	normal
Brightness		
2. Set the pattern generator raster signal to green.
3. Move the deflection yoke to the rear and adjust with the purity control so that the green is at the center and the blue and the red take up equally sized areas on each side.  
(See Figures 3-1 through 3-3.)
4. Move the deflection yoke forward and adjust so that entire screen is green. (See Figure 3-1.)
5. Switch the raster signal to blue, then to red and verify the condition.
6. When the position of the deflection yoke has been decided, fasten the deflection yoke with the screws.
7. If the beam does not land correctly in all the corners, use a magnet to adjust it.  
(See Figure 3-4.)

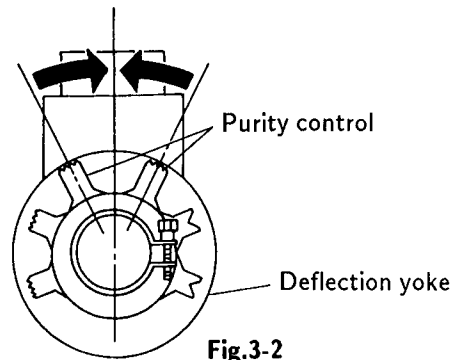

Fig.3-2

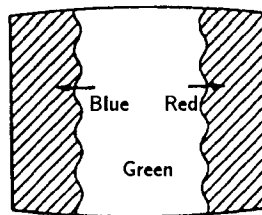

Fig.3-3

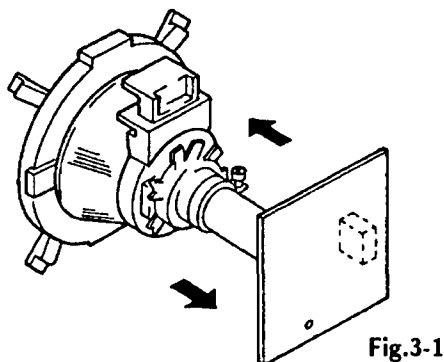

Fig.3-1

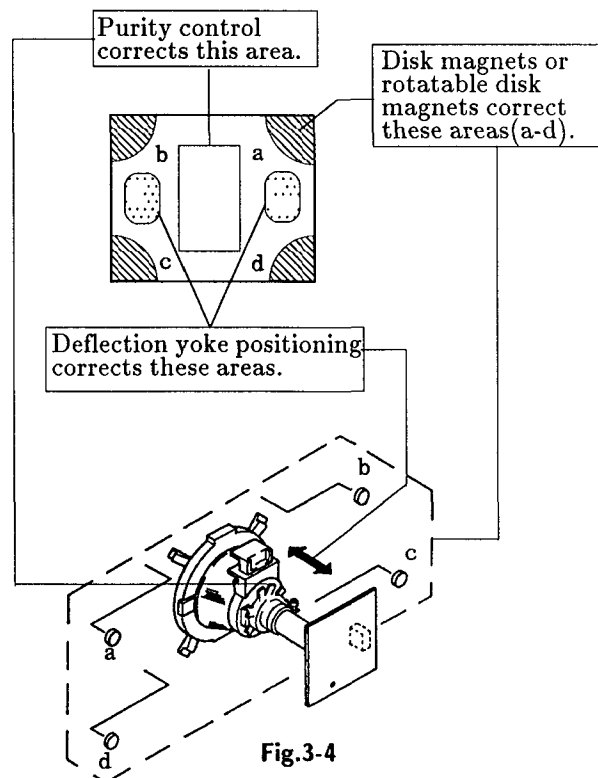

Fig.3-4

**3-2. CONVERGENCE**

**Preparation :**

- Before starting this adjustment, adjust the focus, horizontal size, and vertical size.
- Minimize the brightness setting.
- Provide dot pattern.

(1) **Horizontal and Vertical Static Convergence**

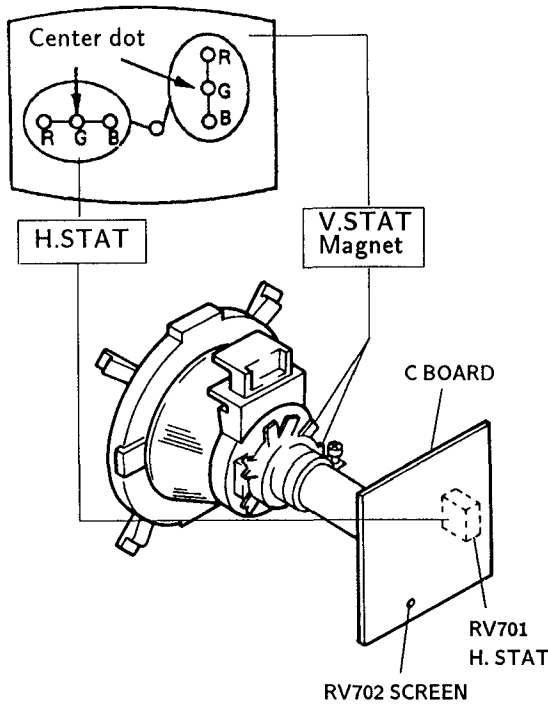

1. (Moving horizontally), adjust the H.STAT control so that the red, green, and blue points are on top of each other at the center of the screen.
2. (Moving vertically), adjust the V.STAT magnet so that the red, green, and blue points are on top of each other at the center of the screen.
3. If the H.STAT variable resistor cannot bring the red, green, and blue points together at the center of the screen, adjust the horizontal convergence with the H.STAT variable resistor and the V. STAT magnet in the manner given below.  
(In this case, the H.STAT variable resistor and the V. STAT magnet influence each other)

- Tilt the V.STAT magnet and adjust the static convergence by opening or closing the V.STAT magnet.

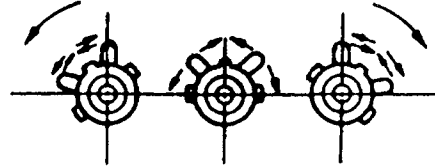

4. If the V.STAT magnet is moved in the direction of the (a) and (b) arrows, the red, green, and blue points move as shown below.

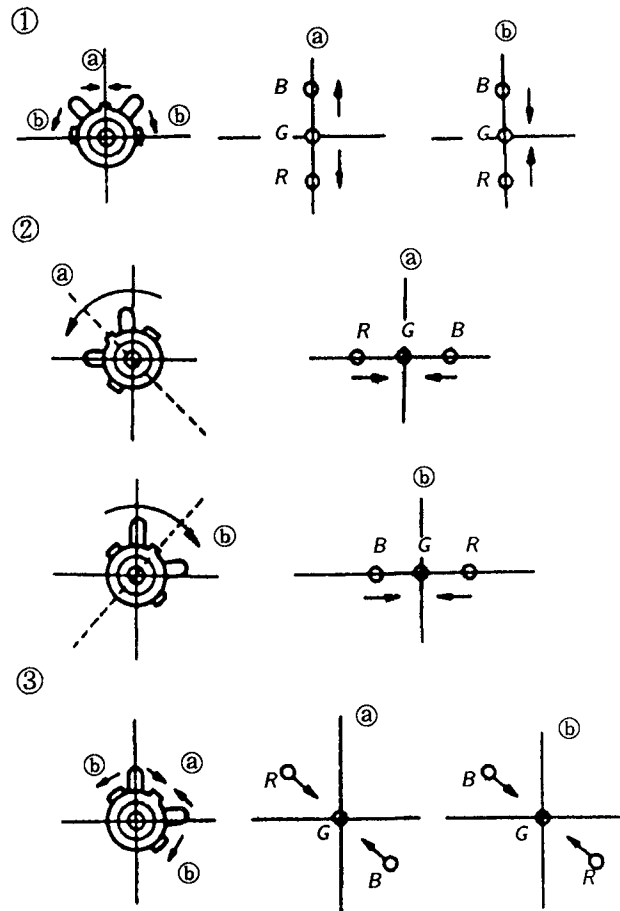

• Operation of BMC (Hexapole) Magnet

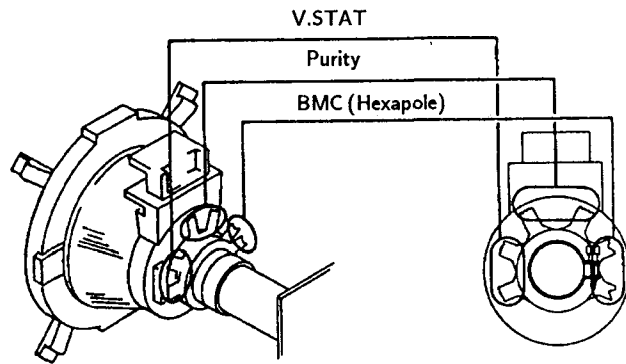
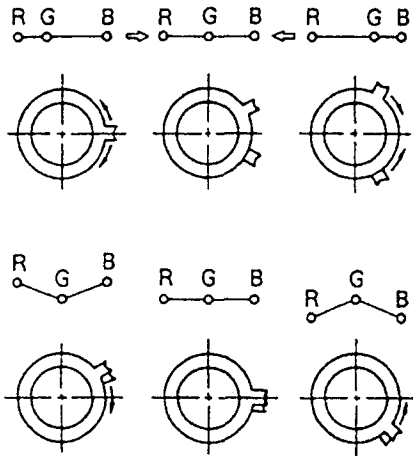

- The respective dot positions resulting from moving each magnet interact, so be sure to perform adjustment while tracking. Use the H.STAT VR to adjust the red, green, and blue dots so they coincide at the center of screen (by moving the dots in the horizontal direction).

• Y separation axis correction magnet adjustment

1. Receive the cross-hatch signal, and adjust [PIX] to "MIN" and [BRT] to "standard".
2. Adjust the deflection yoke to the upright condition when it hits the CRT.
3. Adjust so that the Y separation axis correction magnet on the neck assembly is symmetrical at the top and bottom (open state).
4. Return the deflection yoke to its original position.

(2) Dynamic Convergence Adjustment

Preparations :

- Before starting this adjustment, adjust the horizontal static convergence and the vertical static convergence.

1. Slightly loosen the deflection yoke screws.
2. Remove the deflection yoke spacer.

3. Move the deflection yoke as shown in the figure below and optimize the convergence.
4. Tighten the deflection yoke screws.
5. Install the deflection yoke spacer.

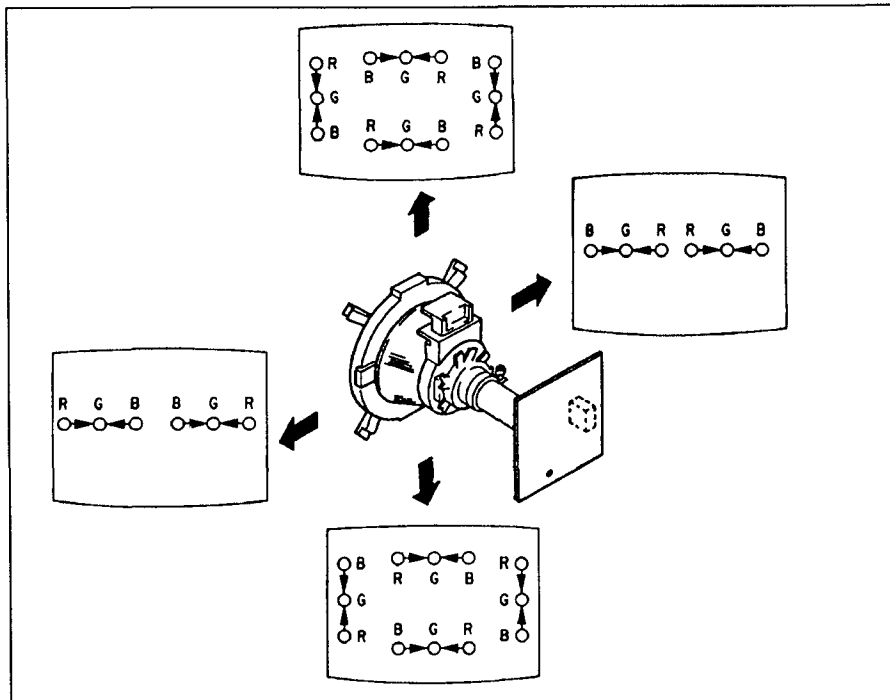

(3) Screen-corner Convergence

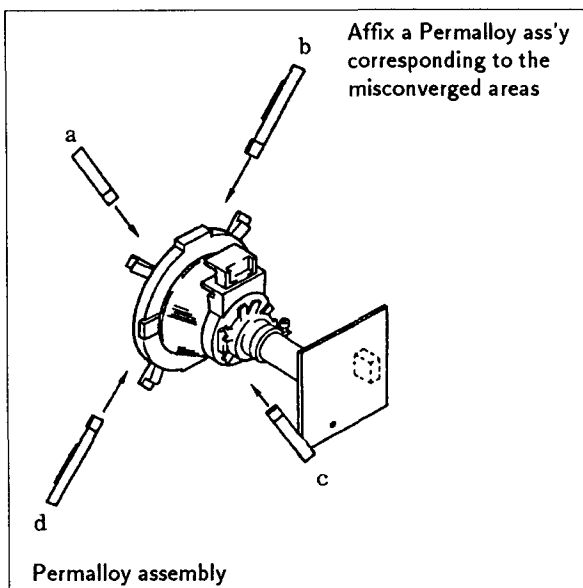
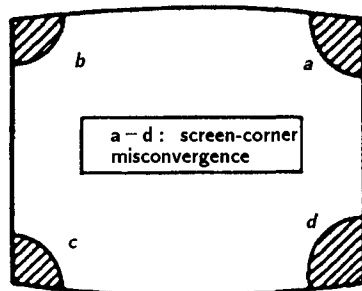

**3-3. FOCUS ADJUSTMENT**

Adjust FOCUS control on the flyback transformer for a best focus.

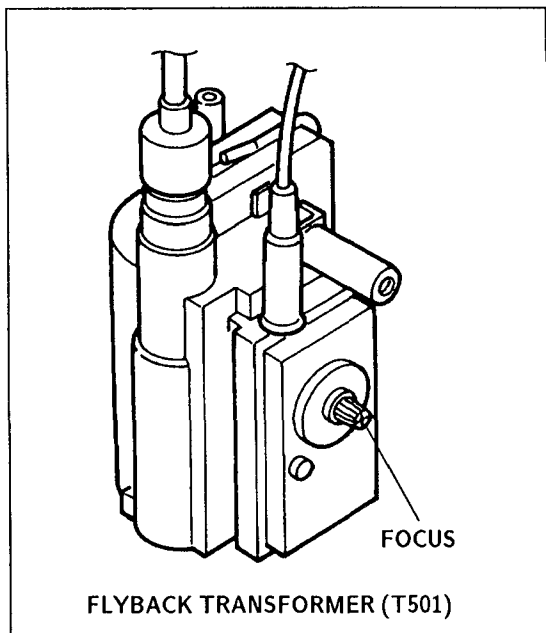

**3-4. G2 (SCREEN) AND WHITE BALANCE ADJUSTMENTS**

**1. G 2 (SCREEN) ADJUSTMENT(RV 702)**

1. Set the PICTURE and BRIGHTNESS to normal.
2. Confirm G 1 voltage is within  $30.0 \pm 5$  V.
3. Apply DC voltage of 180 V to the cathodes of R,G and B from DC stabilized power source.
4. While watching the picture, adjust the G2 control (RV 702) to the just the retrace line disappears.

**2. WHITE BALANCE ADJUSTMENTS**

No.	Disp.	Item	Ave. Data
14	GAMP	Green Amp	20
15	BAMP	Blue Amp	17
16	GCUT	Green Cut-off	7
17	BCUT	Blue Cut-off	8
22	SBRT	Sub Bright	35

1. Input an entire white signal.
2. Set to service adjustment mode.
3. Set the PICTURE and BRIGHT to minimum.
4. Adjust with SBRT if necessary.
5. Select G CUT and B CUT with **1** and **4**.
6. Adjust with **3** and **6** for the best white balance.
7. Set the PICTURE and BRIGHT to maximum.
8. Select GAMP and BAMP with **1** and **4**.
9. Adjust with **3** and **6** for the best white balance.
10. Write into the memory by pressing **MUTING** then **ENTER**.

**3. SUB BRIGHT ADJUSTMENT**

1. Set to service mode.
2. Input a staircase signal of black and white from the pattern generator.
3. BRIGHTNESS ... RESET  
PICTURE ..... minimum
4. Select SBRT with **1** and **4**, and adjust SUB BRIGHT level with **3** and **6** so that the stripe second from the right is dimly lit.

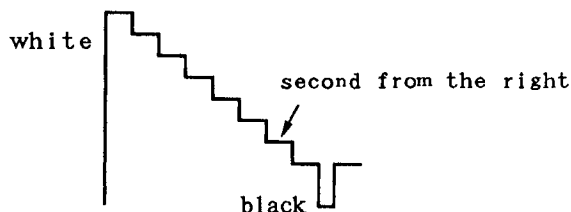

## SECTION 4 SAFETY RELATED ADJUSTMENTS

### ☒ R511 CONFIRMATION METHOD (HOLD-DOWN CONFIRMATION) AND READJUSTMENTS

The following adjustments should always be performed when replacing the following components (marked with ☒ on the schematic diagram). PM501, R338, R511, R632, R645, R650

①

#### 1. Preparation before confirmation

- 1) Remove R635 on the D board and connect a variable resistor (RV1: about  $4.7k\Omega$ - $10k\Omega$ ) between pin ① of IC601 and B+ line.
- 2) Supply  $130 \pm 2.0V$  AC to with variable auto-transformer.

#### 2. Hold-down operation confirmation

- 1) Turn the POWER switch ON, and receive entirely white signals and adjust ABL current to  $1760 \pm 50\mu A$  with PICTURE and BRIGHT etc controls.
- 2) Increase B+ line voltage gradually by adjusting the resistor of RV1. Confirm that the minimum voltage is less than  $142.5V$  DC whereby the raster disappears during operation of hold-down circuit.

**NOTE:** When the hold-down circuit starts operating, switch OFF the POWER of the set immediately.

- 3) Turn the POWER switch ON, and receive dot signals and adjust ABL current to  $160 \pm 50\mu A$  with PICTURE and BRIGHT etc controls.
- 4) Increase B+ line voltage gradually by adjusting the resistor of RV1. Confirm that the minimum voltage is less than  $145.0V$  DC whereby the raster disappears during operation of hold-down circuit.

**NOTE:** When the hold-down circuit starts operating, switch OFF the POWER of the set immediately.

#### 3. Hold-down readjustment

When step 2 is not satisfied, readjustment should be performed by altering the resistance value of R511 (a component marked with ☒).

### ☒ R524 CONFIRMATION METHOD (HOLD-DOWN CONFIRMATION) AND READJUSTMENTS

The following adjustments should always be performed when replacing the following components (marked with ☒ on the schematic diagram). IC601, PM501, D504, C598, R338, R509, R524, R632, R635, R645, T501

②

#### 1. Preparation before confirmation

- 1) Turn the POWER switch ON, and receive entirely white signals and set the PICTURE and BRIGHT controls to maximum.
- 2) Confirm that voltage of the check terminal of TP-85 (D BOARD) is more than  $114.0V$  DC when the set is operating normally with  $120.0 \pm 2.0V$  AC supply.

#### 2. Hold-down operation confirmation

- 1) Turn the POWER switch ON, and receive entirely white signals and adjust ABL current to  $1760 \pm 50\mu A$  with PICTURE and BRIGHT etc controls.
- 2) Apply DC voltage of over  $130.0V$  DC gradually to the check terminal of TP-85 (D BOARD) via 1T40 from the DC stabilized power source. Confirm that the minimum voltage is less than  $137.5V$  DC whereby the raster disappears during operation of hold-down circuit.

**NOTE:** When the hold-down circuit starts operating, switch OFF the POWER of the set immediately.

- 3) Turn the POWER switch ON, and receive dot signals and adjust ABL current to  $160 \pm 50\mu A$  with PICTURE and BRIGHT etc controls.
- 4) Apply DC voltage of over  $130.0V$  gradually to the check terminal of TP-85 (D BOARD) via 1T40 from the DC stabilized power source. Confirm that the minimum voltage is less than  $138.0V$  DC whereby the raster disappears during operation of hold-down circuit.

**NOTE:** When the hold-down circuit starts operating, switch OFF the POWER of the set immediately.

#### 3. Hold-down readjustment

When step 2 is not satisfied, readjustment should be performed by altering the resistance value of R524 (a component marked with ☒).

### B+ VOLTAGE CONFIRMATION

The following adjustments should always be performed when replacing IC601 and R635.

- 1) Supply  $130 \pm 2.0V$  AC to with variable autotransformer.
- 2) Receive entirely monoscope signal.
- 3) Set the PICTURE control and the BRIGHT controls in to initial reset.
- 4) Confirm the voltage of TP91 is less than  $137.0V$  DC.
- 5) If step 4) is not satisfied, replace IC601 and R635 repeat above steps.

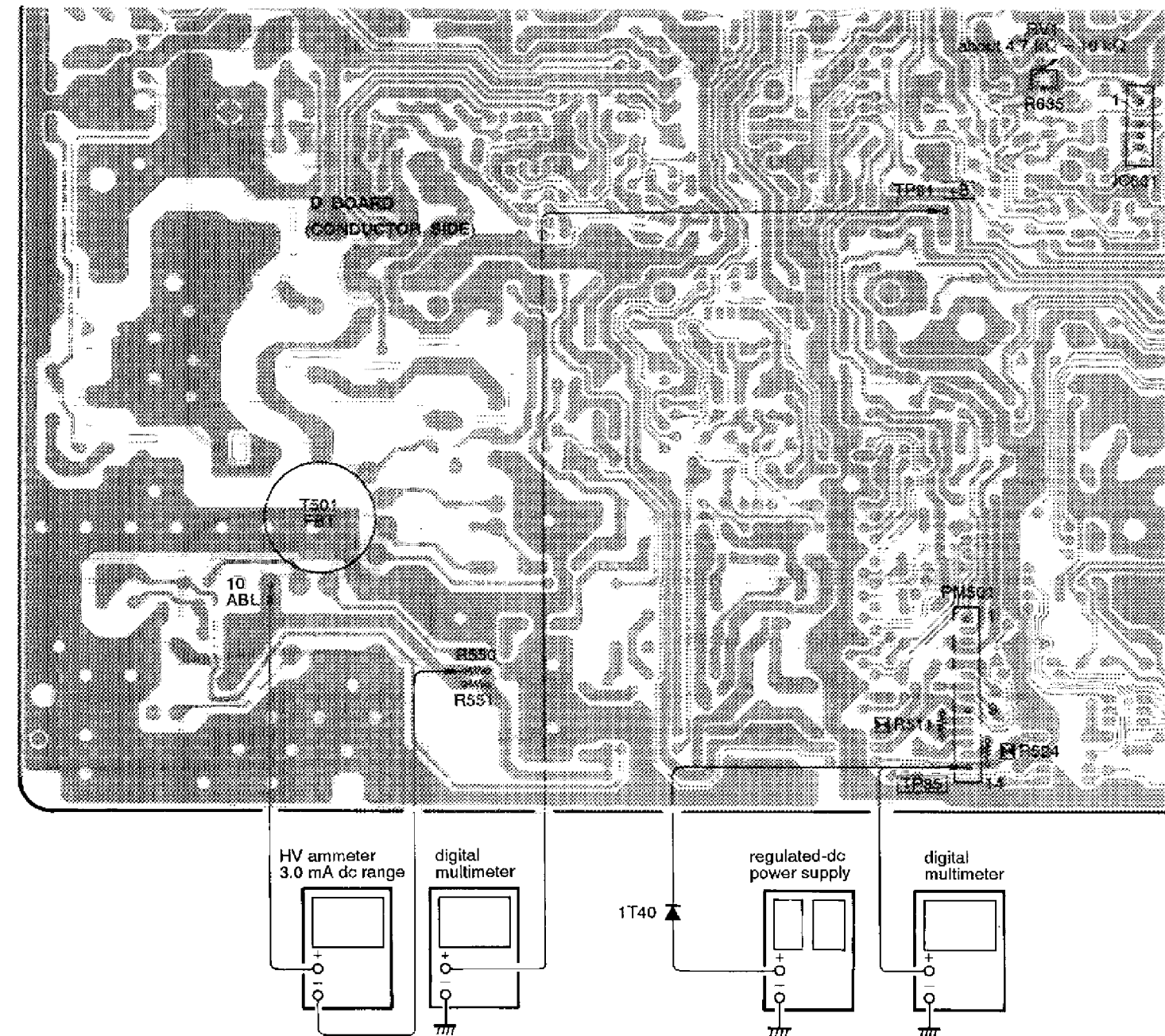
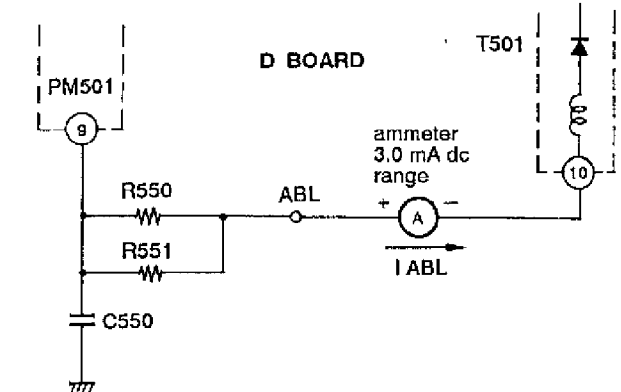

## SECTION 5 CIRCUIT ADJUSTMENTS

### 5-1. ELECTRICAL ADJUSTMENT BY REMOTE COMMANDER

Use of Remote Commander can be performed circuit adjustments about this model.

NOTE : Test Equipment Required.

1. Pattern Generator
2. Frequency counter
3. Digital multimeter
4. Audio OSC

#### 1. METHOD OF SETTING THE SERVICE ADJUSTMENT MODE

SERVICE MODE PROCEDURE

1. Standby mode.(Power off)
2. **DISPLAY** → **5** → **VOL (+)** → **POWER** on the Remote Commander. (Press each button within a second.)

SERVICE ADJUSTMENT MODE IN

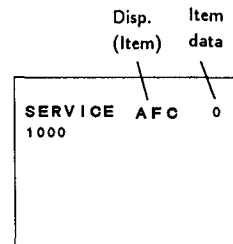

3. The CRT displays the item Being adjusted.
4. Press **1** or **4** on the Remote Commander to select the item.
5. Press **3** or **6** on the Remote Commander to change the data.
6. Press **MUTING** then **ENTER** to write into memory.

SERVICE ADJUSTMENT MODE MEMORY

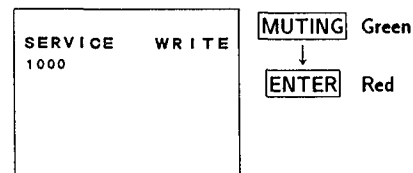

7. Press **8** then **ENTER** on the Remote Commander to initialize.

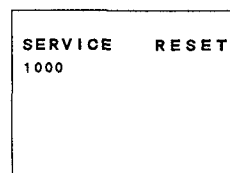

Carry out step 7) when adjusting IDs 0 to 4 and when replacing and adjusting IC102.

Factory original setting

8. Turn set off and on to exit.

#### 2. MEMORY WRITE CONFIRMATION METHOD

1. After adjustment, pull out the plug from AC outlet, and next place, plug in AC outlet again.
2. Turn the power switch ON and set to Service Mode.
3. Call the adjusted items again, confirm they were adjusted.

#### 3. ADJUST BUTTONS AND INDICATOR

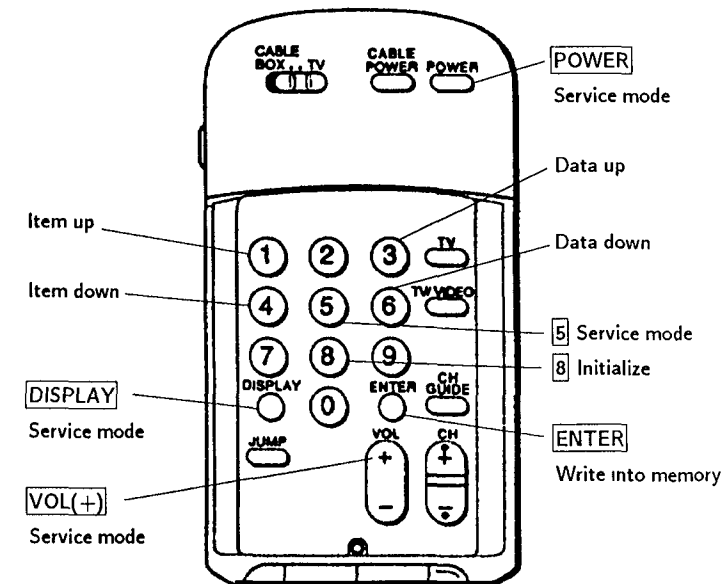
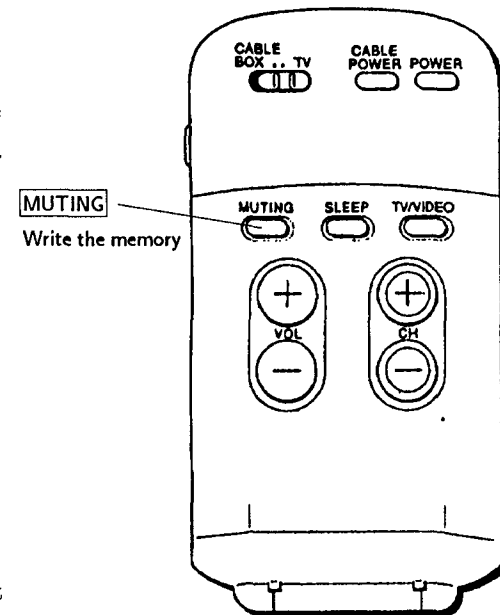

RM-Y119

#### 4. AN ITEM OF ADJUSTMENTS

No.	Disp.	Item	Data range	Ave. data
1	AFC	AFC Loop Gain	0~3	* 0
2	HFRE	H. Frequency	0~127	70
3	VFRE	V. Frequency	0~31	16
4	VPOS	V. Center	0~31	17
5	VSIZ	V. Size	0~63	28
6	VLIN	V. Linearity	0~15	8
7	VSCO	V. Correction	0~15	6
8	HPOS	H. Center	0~15	6
9	HSIZ	H. Size	0~31	31
10	PAMP	Pin Amp	0~31	24
11	CPIN	Corner Pin	0~7	3
12	PPHA	Pin Phase	0~15	6
13	VCOM	V. Compensation	0~7	* 2
14	GAMP	Green Amp	0~31	20
15	BAMP	Blue Amp	0~31	17
16	GCUT	Green Cut Off	0~15	7
17	BCUT	Blue Cut Off	0~15	8
18	CROM	Chroma Trap	0~63	* 28
19	SPIX	Sub Contrast	0~63	20
20	SHUE	Sub Hue	0~63	33
21	SCOL	Sub Color	0~63	32
22	SBRT	Sub Bright	0~63	35
23	RGBP	RGB Picture	0~63	* 10
24	SHAP	Sharpness	0~15	* 7
25	VSMO	V Pull in Range	0, 1	* 0
26	REF	Refference line	0~3	* 2
27	ROFF	Red Out	0, 1	1
28	GOFF	Green Out	0, 1	1
29	BOFF	Blue Out	0, 1	1
30	ABLM	ABL Mode	0, 1	* 0
31	NOTC	Notch On/Off	0, 1	* 1
32	DRGB	OSD intensity	0, 1	* 0
33	VANG	V. Angle	0~63	0
34	DISP	Display Position	0~63	40
35	SVOL	Sub Volume	0~15	* 0
36	SBAL	Sub Balance	0~15	7
37	BASS	Sub Bass	0~15	* 8
38	TRE	Sub Treble	0~15	* 8
39	UYBO	Upper Y. Bow	0~63	—
40	LYBO	Lower Y. Bow	0~63	—
41	HAMP	H. Amp	0~63	—
42	HTIL	H. Tilt	0~63	—
43	UCBO	Upper C. Bow	0~63	—
44	UTIL	Upper Tilt	0~63	—
45	LCBO	Lower C. Bow	0~63	—
46	LTIL	Lower Tilt	0~63	—
47	DCSH	DC. Shift	0~63	—
48	PHPO	PinP H Position	0~127	76
49	PHUE	PinP Hue	0~31	* 0
50	ID-0	Model ID	0~127	by Model
51	ID-1	Model ID	0~127	by Model
52	ID-2	Model ID	0~127	by Model
53	ID-3	Model ID	0~127	by Model
54	ID-4	Model ID	0~127	by Model

\* Set-up value

Note : No. from 1 to 54 is to show adjustment order.

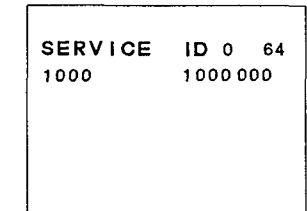

Please adjust the function values as shown below when IC 102 on M board was replaced.

KV-27V 55 (US/CND)

No.	Disp.	Disp.	Data
50	ID-0	1 1 1 1 0 0 0	120
51	ID-1	1 1 1 1 1 1 1	127
52	ID-2	1 0 0 1 0 0 0	72
53	ID-3	1 0 0 0 0 0 0	64
54	ID-4	0 0 1 0 0 0 0	16

KV-29V55M (E)

No.	Disp.	Disp.	Data
50	ID-0	1 1 1 1 0 0 0	120
51	ID-1	1 1 1 1 1 1 1	127
52	ID-2	0 1 0 1 0 0 0	40
53	ID-3	1 0 0 0 0 0 0	64
54	ID-4	0 0 1 0 0 0 0	16

## 5-2. M BOARD ADJUSTMENTS

### H.FREQUENCY ADJUSTMENT (HFRE)

1. Input a color-bar signal.
2. Set to Service adjustment Mode.
3. Connect a frequency counter to CN131 Pin⑬ (H. DRIVE) connector and ground.
4. Call the item of AFC, set to 3 level (free run).
5. Select HFRE with **[1]** and **[4]**.
6. Adjust with **[3]** and **[6]** for the  $15734 \pm 60\text{Hz}$ .
7. Call the item of AFC again, adjust the level "0".
8. Write into the memory by pressing **[MUTING]** then **[ENTER]**.

### V.FREQUENCY ADJUSTMENT (VFRE)

1. Select video 1 with no connecting the signal.
2. Set to Service adjustment Mode.
3. Connect the frequency counter across connector CN131 Pin⑦ (V. DRIVE) connector and ground.
4. Select VFRE with **[1]** and **[4]**.
5. Adjust with **[3]** and **[6]** for the  $55 \pm 0.5\text{Hz}$ .
6. Write the memory by pressing **[MUTING]** then **[ENTER]**.

### SUB CONTRAST ADJUSTMENT (SPIX)

1. Input a color-bar signal.
2. Set to Service adjustment Mode.
3. Set the conditions as follows.

PICTURE ..... MAX  
 COLOR ..... MIN  
 BRIGHT ..... CENTER  
 R OFF ..... ON (1)  
 G OFF ..... OFF (0)  
 B OFF ..... OFF (0)

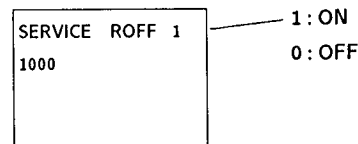

4. Connect an oscilloscope to CN703 Pin① (R OUT) of C board and ground.
5. Select SPIX with **[1]** and **[4]**.
6. Adjust with **[3]** and **[6]** for the  $1.9 \pm 0.1\text{Vp-p}$ .

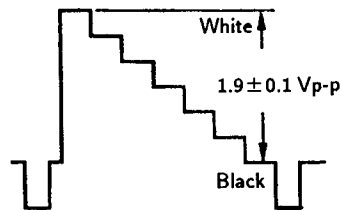

7. Write the memory by pressing **[MUTING]** then **[ENTER]**.
8. Return the following back to normal after adjustment.

PICTURE ..... MAX  
 BRIGHT ..... CENTER  
 COLOR ..... CENTER  
 R OFF ..... ON  
 G OFF ..... ON  
 B OFF ..... ON

**SUB HUE, SUB COLOR ADJUSTMENT (SHUE, SCOL)**

1. Input a color-bar signal.
2. Set to service adjustment mode.
3. Connect an oscilloscope to CN703 Pin③ (B OUT) of C board.
4. Select SHUE and SCOL with **1** and **4**.
5. Adjust with **3** and **6** for the  $V1=V4$  (SCOR) and  $V2=V3$  (SHUE).

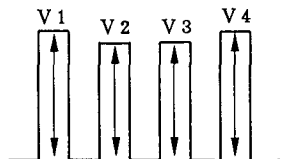

6. Increase the data of SCOL by 5 steps.
7. Write into the memory by pressing **MUTING** then **ENTER**.

**SUB BARANCE ADJUSTMENT (SBAL)**

1. Input a stereo signal.
2. Set to service adjustment mode.
3. Select SBAL with **1** and **4**.
4. Adjust with **3** and **6** for the best sound balance
5. Write into the memory by pressing **MUTING** then **ENTER**.

**DISPLAY POSITION ADJUSTMENT (DISP)**

1. Input a color-bar signal.
2. Set to service adjustment Mode.
3. Select DISP with **1** and **4**.
4. Adjust with **3** and **6** for the bar center.
5. Write the memory by pressing **MUTING** then **ENTER**.

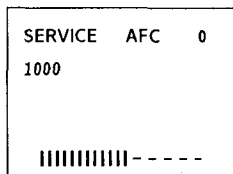

**H.CENTER ADJUSTMENT (H POS)**

Note: Perform this adjustment after H.FREQUENCY ADJUSTMENT (HFRE).

1. Input a cross-hatch signal.
2. Set the Service adjustment mode.
3. Select HPOS with **1** and **4**.
4. Adjust with **3** and **6** to the best horizontal center.
5. Write into the memory by pressing **MUTING** then **ENTER**.

H. CENTER (HPOS)

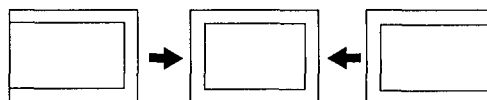

**H.SIZE ADJUSTMENT (HSIZ)**

1. Input a cross-hatch signal.
2. Set to service adjustment Mode.
3. Select HSIZ with **1** and **4**.
4. Adjust with **3** and **6** for best horizontal size.
5. Write into the memory by pressing **MUTING** then **ENTER**.

H. SIZE (HSIZ)



**V.CENTER ADJUSTMENT (VPOS)**

1. Input a cross-hatch signal.
2. Set to service adjustment Mode.
3. Select VPOS with **1** and **4**.
4. Adjust with **3** and **6** for the best vertical center.
5. Write into the memory by pressing **MUTING** then **ENTER**.

V. CENTER (VPOS)

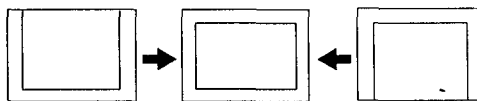

**V.SIZE ADJUSTMENT (VSIZ)**

1. Input a cross-hatch signal.
2. Set to service adjustment Mode.
3. Select VSIZ with **1** and **4**.
4. Adjust with **3** and **6** for the best vertical size.
5. Write into the memory by pressing **MUTING** then **ENTER**.

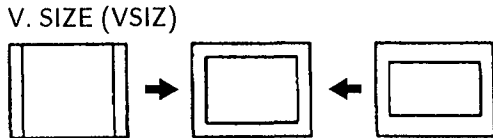

**V LINEARITY(VLIN), VS CORRECTION(VSCO), PIN AMP(PAMP), CORNER PIN(CPIN), AND PIN PHASE(PPHA) ADJUSTMENTS**

1. Input a cross-hatch signal.
2. Set to Service adjustment Mode.
3. Select VLIN, VSCO, PAMP, CPIN, and PPHA with **1** and **4**.
4. Adjust with **3** and **6** for the best picture.
5. Write the memory by pressing **MUTING** then **ENTER**.

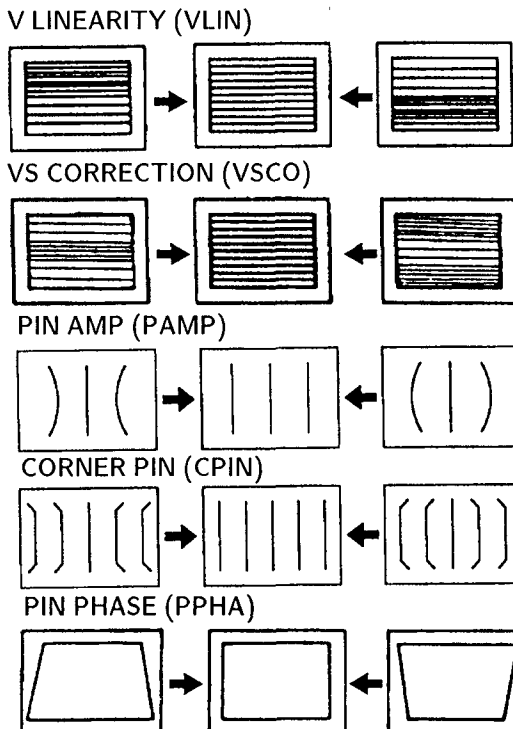

**CROMA TRAP ADJUSTMENT (CROM)**

1. Input a red signal
2. Set to Service adjustment Mode.
3. Connect an oscilloscope CN703 Pin① (R OUT) of C board ground.
4. Select CROM with **1** and **4**.
5. Adjust with **3** and **6** for the 0 level.

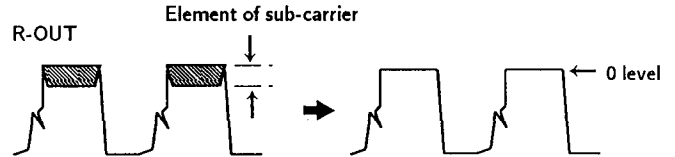

6. Write the memory by pressing **MUTING** then **ENTER**.

**5-3. P BOARD ADJUSTMENTS**

**P IN P H. POSITION (PHPO)**

1. Input a color-bar signal
2. Set to Service adjustment Mode.
3. Select PHPO with **1** and **4**.
4. Adjust with **3** and **6** for the best balanced center position at 4 corner PinP display position.
5. Write the memory by pressing **MUTING** then **ENTER**.



SECTION 6  
DIAGRAMS

-1. BLOCK DIAGRAMS

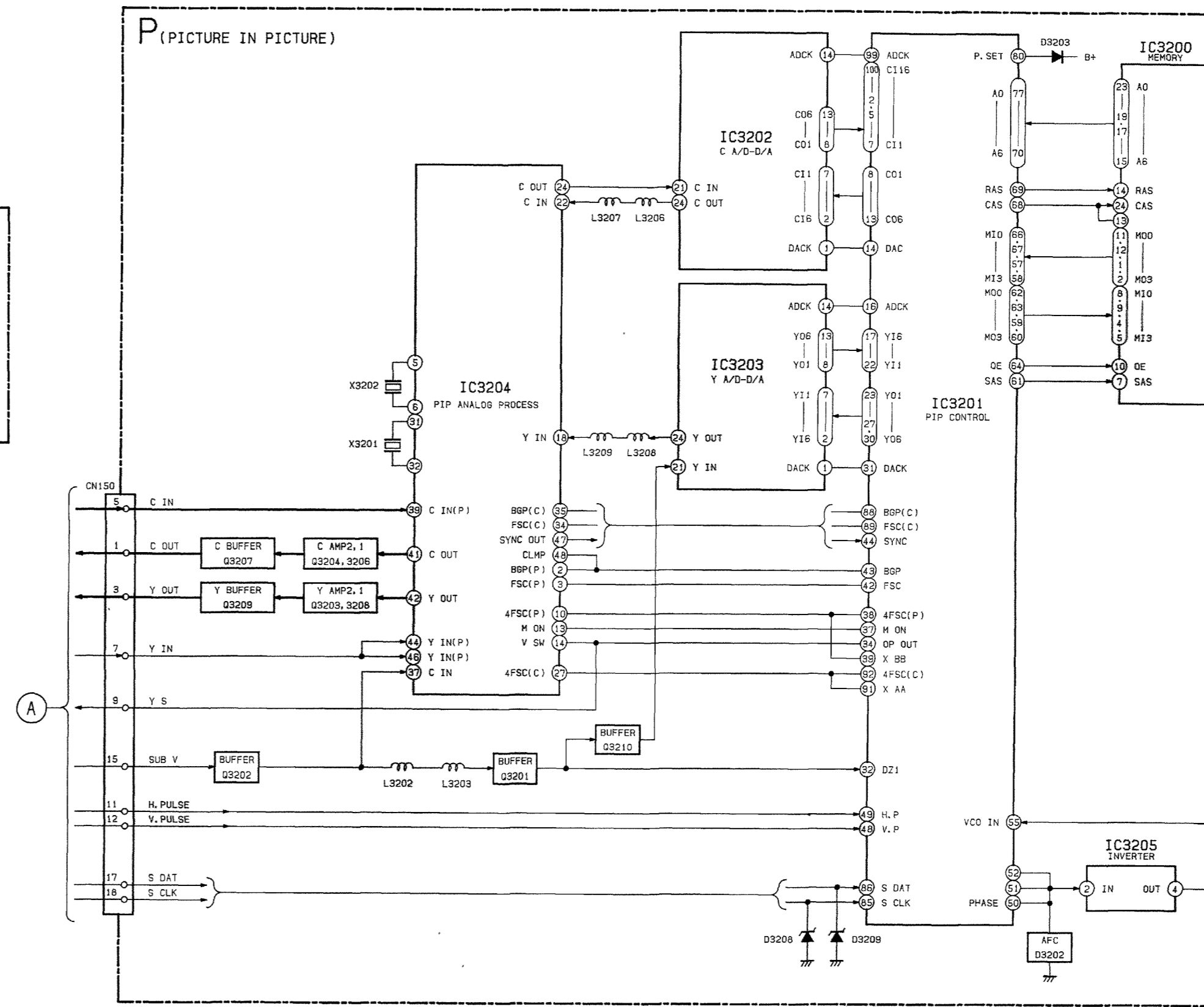
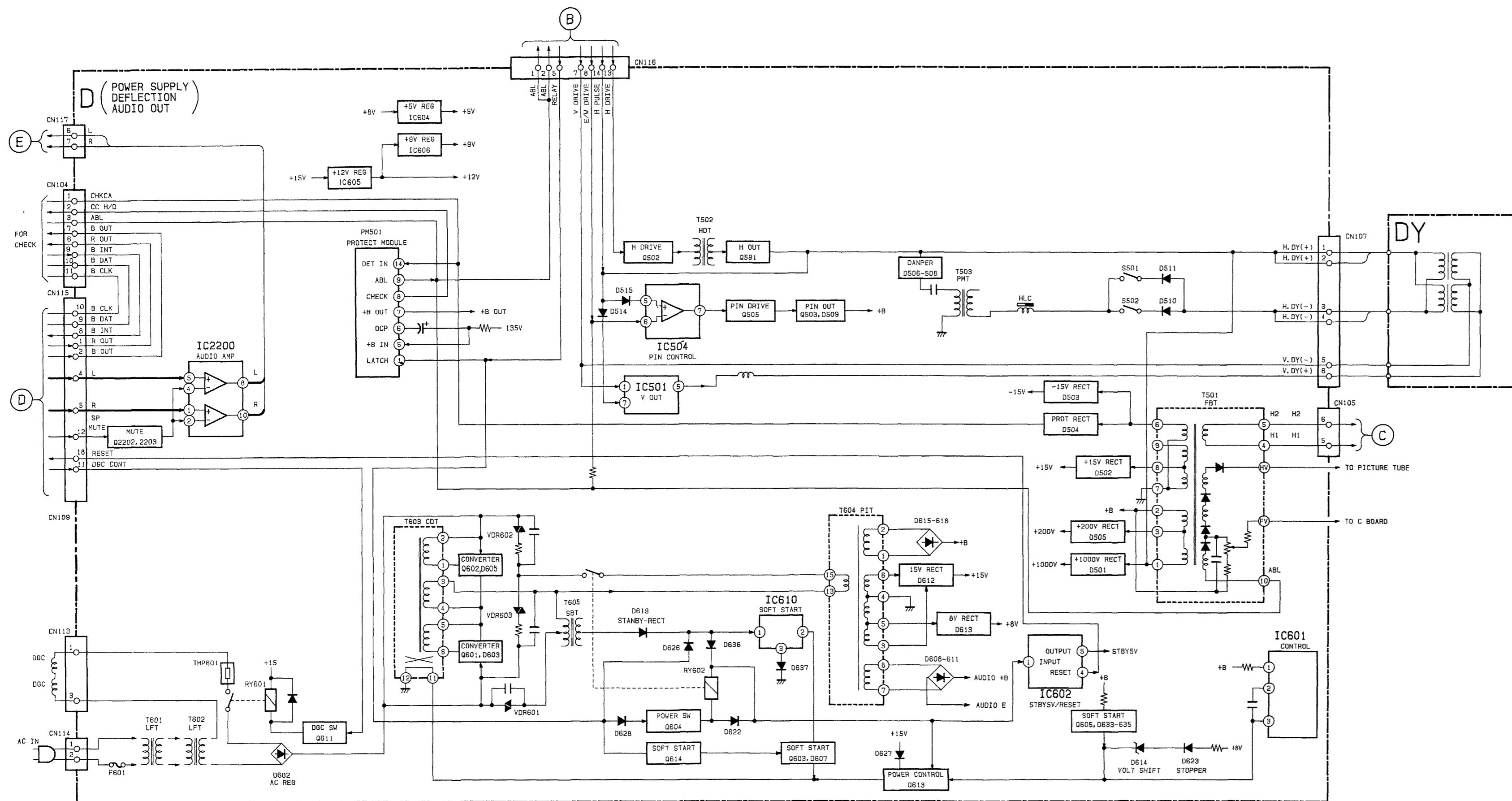







**D** POWER SUPPLY  
DEFLECTION  
AUDIO OUT

- D Board -

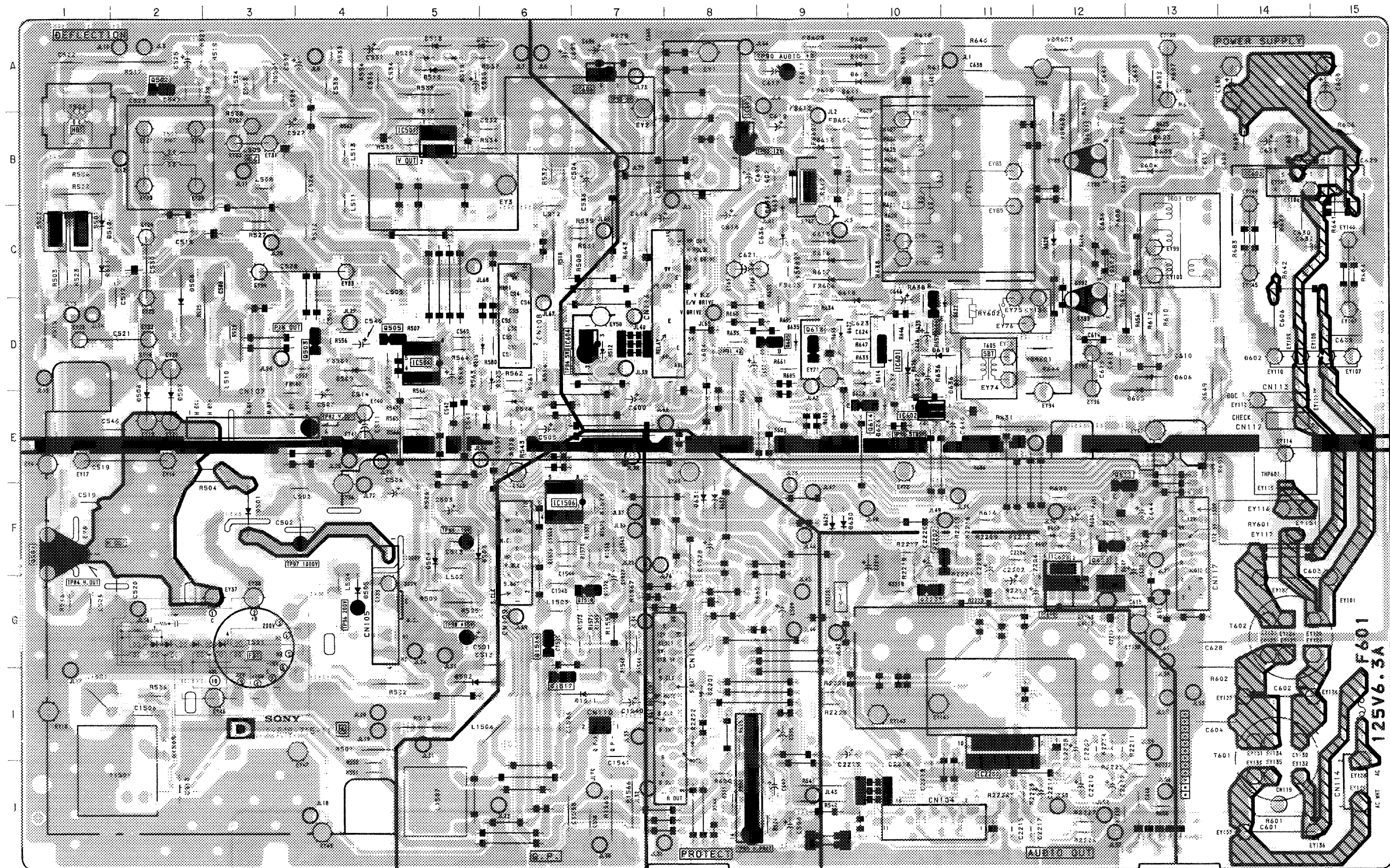

• D BOARD

IC	DIODE
IC501	B-5
IC504	D-5
IC601	D-10
IC604	E-10
IC602	D-7
IC605	B-8
IC606	A-7
IC610	G-12
IC2200	I-11
D501	F-3
D502	H-5
D503	F-5
D504	F-5
D505	G-4
D506	E-2
D507	E-2
D508	D-2
D509	D-4
D510	C-1
D511	C-1
D512	D-7
D513	A-5
D514	E-6
D515	D-6
D601	E-13
D602	D-14
D603	B-13
D605	E-13
D607	F-12
D608	A-10
D609	A-10
D610	A-10
D611	A-10
D612	B-9
D613	B-9
D614	D-10
D615	C-9
D616	C-9
D617	C-9
D618	D-10
D619	D-10
D622	D-11
D623	D-10
D624	E-10
D626	D-9
D627	D-10
D628	E-9
D629	F-9
D630	F-9
D631	F-8
D632	F-8
D633	C-9
D634	C-9
D635	D-9
D636	D-11
D637	F-12
D638	F-12
Q502	A-2
Q503	D-4
Q505	D-5
Q591	F-1
Q601	B-12
Q602	C-12
Q603	F-12
Q604	D-10
Q605	D-10
Q611	F-9
Q613	D-9
Q614	E-10
Q2202	F-10
Q2203	G-10

TRANSISTOR

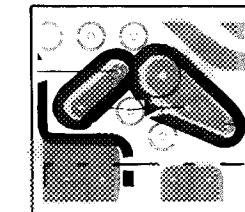

**NOTE:**  
The circuit indicated as left contains high voltage of over 600 Vp-p. Care must be paid to prevent an electric shock in inspection or repairing.





(3) Schematic Diagram of UA Board

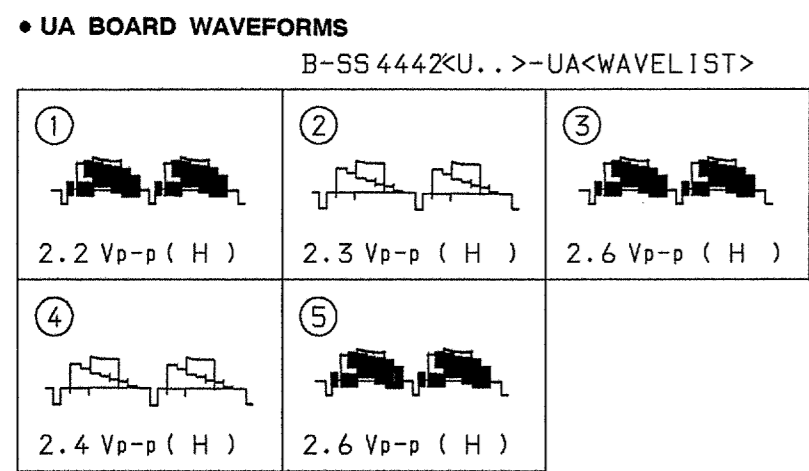
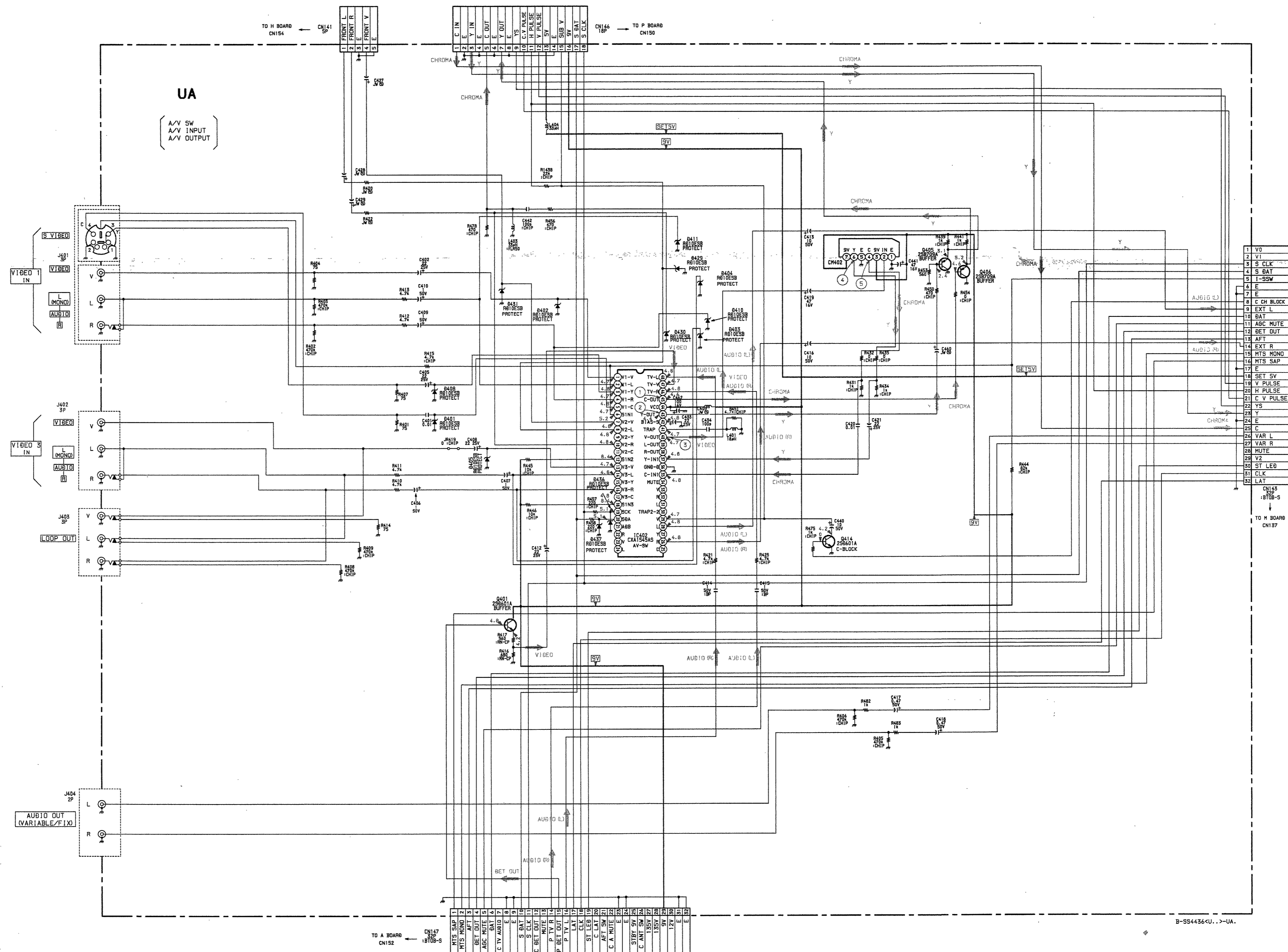

1	VO
2	V1
3	S CLK
4	S BAT
5	I-SSV
6	E
7	E
8	C CH BLOCK
9	EXT L
10	BAT
11	ABC MUTE
12	BET OUT
13	AFT
14	EXT R
15	MTS MOND
16	MTS SAP
17	E
18	SET SV
19	V PULSE
20	H PULSE
21	C V PULSE
22	YS
23	Y
24	E
25	C
26	VAR L
27	VAR R
28	MUTE
29	V2
30	ST LED
31	CLK
32	LAT



## • UA BOARD

IC	
IC402	C-5
TRANSISTOR	
Q401	D-1
Q405	E-8
Q406	D-8
Q414	B-6
DIODE	
D401	D-2
D402	D-3
D403	D-3
D404	C-3
D405	C-4
D408	D-2
D410	E-2
D411	D-5
D429	C-5
D430	C-5
D431	C-4
D436	B-5
D437	B-5

**P** [PICTURE IN PICTURE]

- P Board (Conductor Side) -

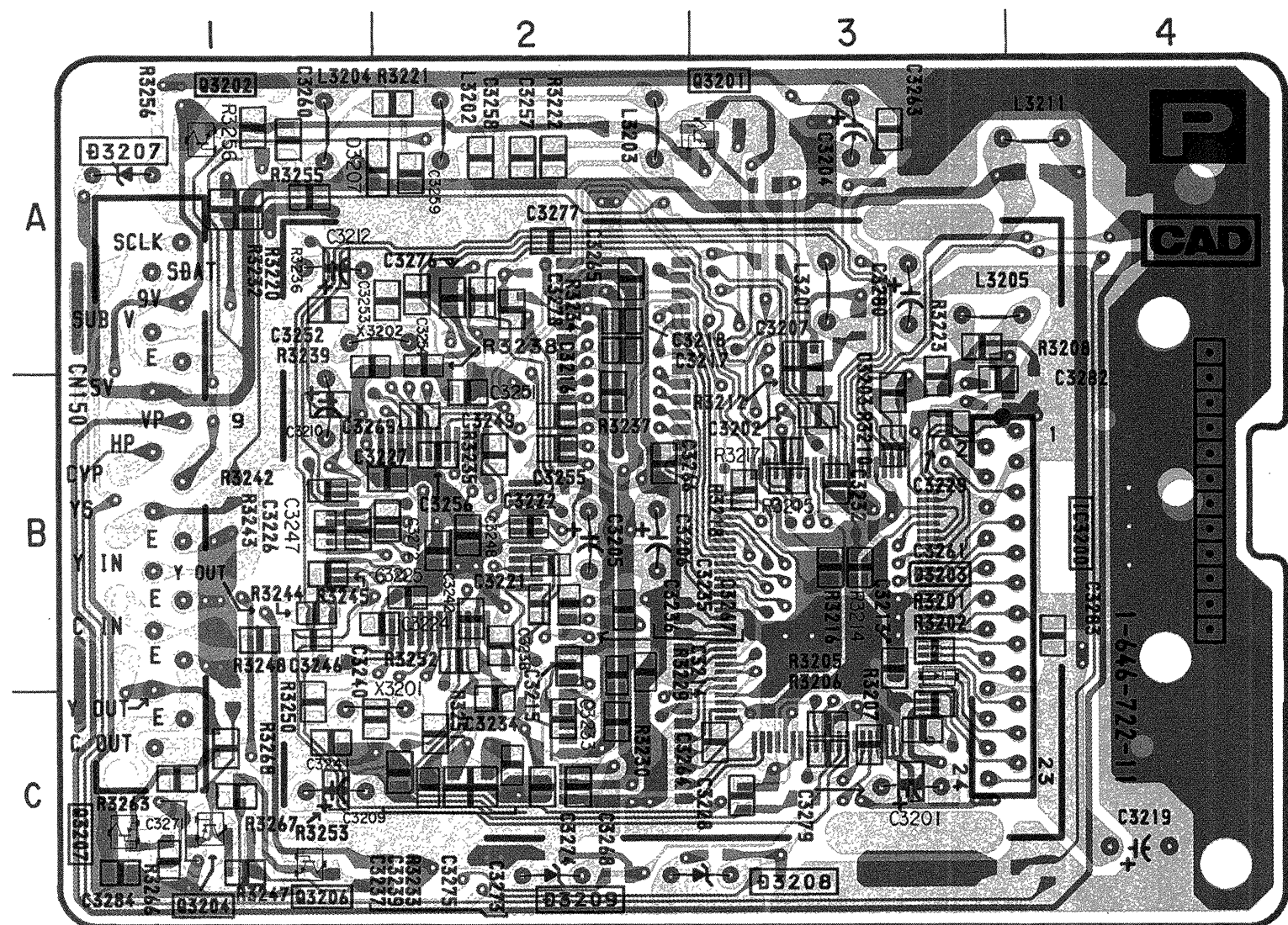

• : Pattern on the side which is seen.  
• : Pattern of the rear side.

- P Board (Component Side) -

• P BOARD

IC	(Conductor Side) (Component Side)	
	IC3200	B-4
IC3201		B-2
IC3202		B-3
IC3203		A-3
IC3204		B-3
IC3205		B-1

TRANSISTOR	(Conductor Side) (Component Side)	
	Q3201	A-3
Q3202	A-1	
Q3203	B-3	C-4
Q3204	C-1	
Q3206	C-1	
Q3207	C-1	
Q3208		C-3
Q3209		C-4
Q3210		A-2

DIODE	(Conductor Side) (Component Side)	
	D3202	
D3203		B-3
D3208	C-3	C-2
D3209	C-2	C-3

CRYSTAL	(Conductor Side) (Component Side)	
	X3201	C-2
X3202	A-2	A-3

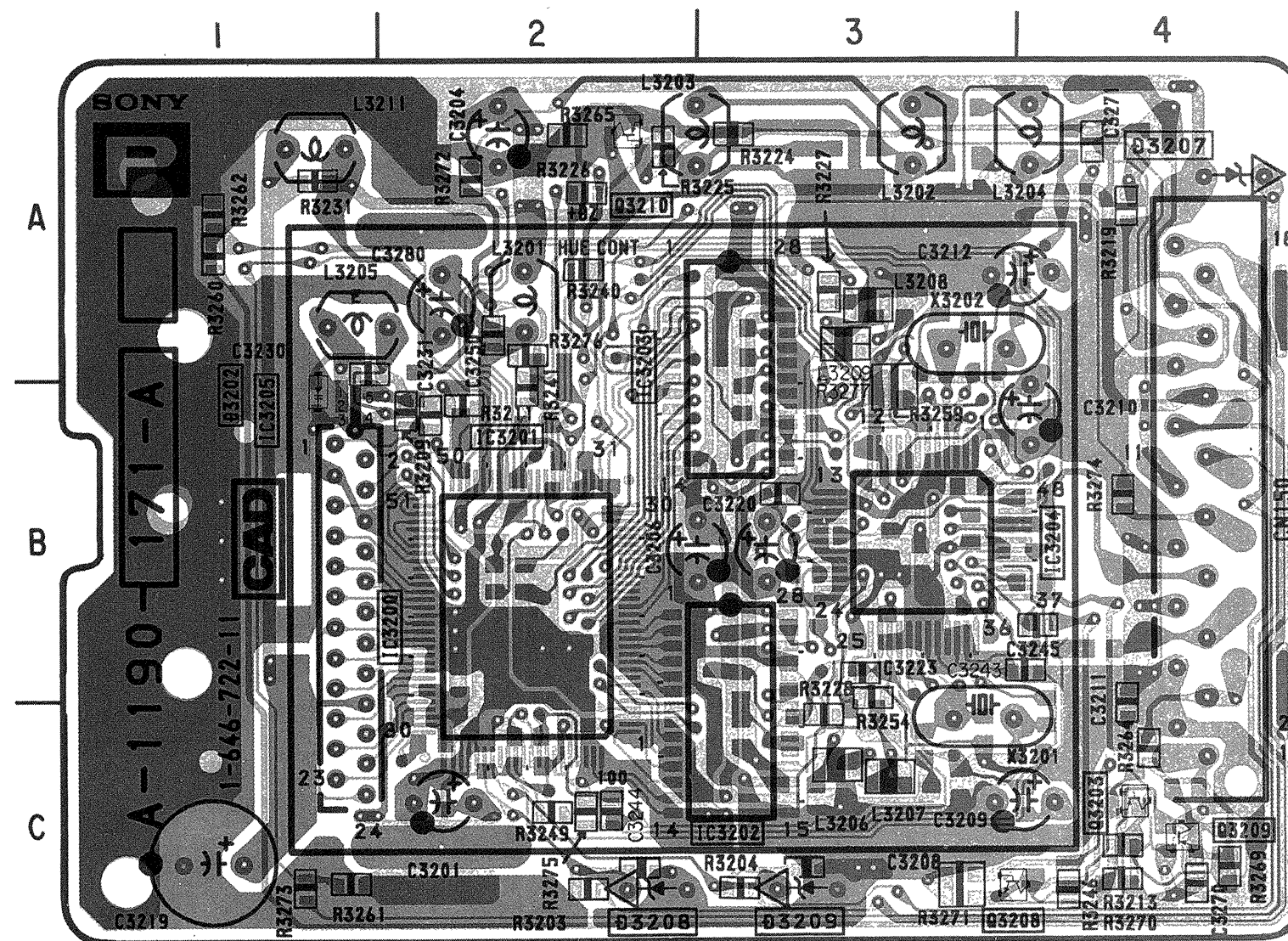

• : Pattern on the side which is seen.  
• : Pattern of the rear side.

(4) Schematic Diagram of P Board

A  
B  
C  
D  
E  
F  
G  
H  
I  
J  
K  
L  
M  
N  
O  
P

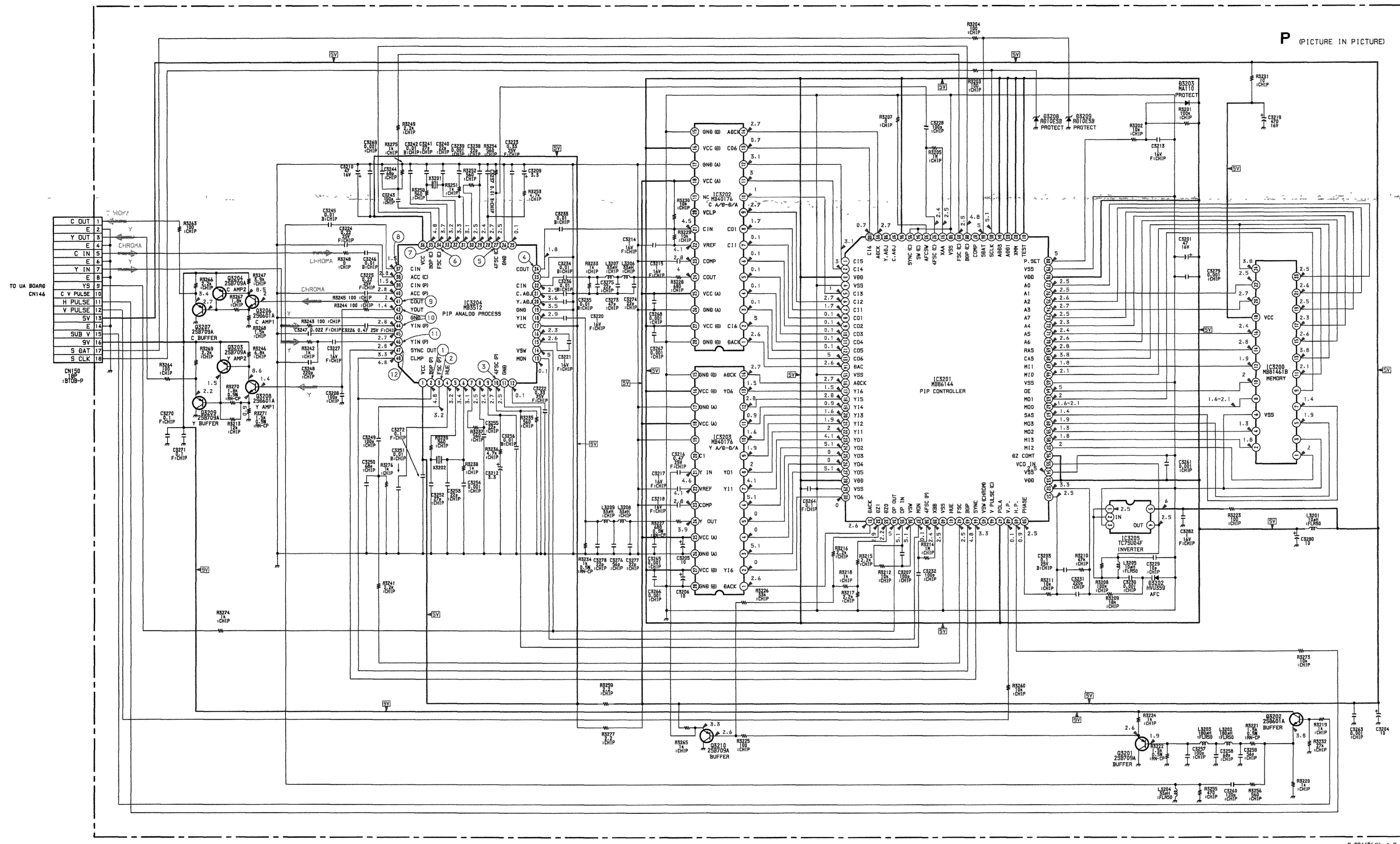

P Board IC3202, IC3203 MB40176

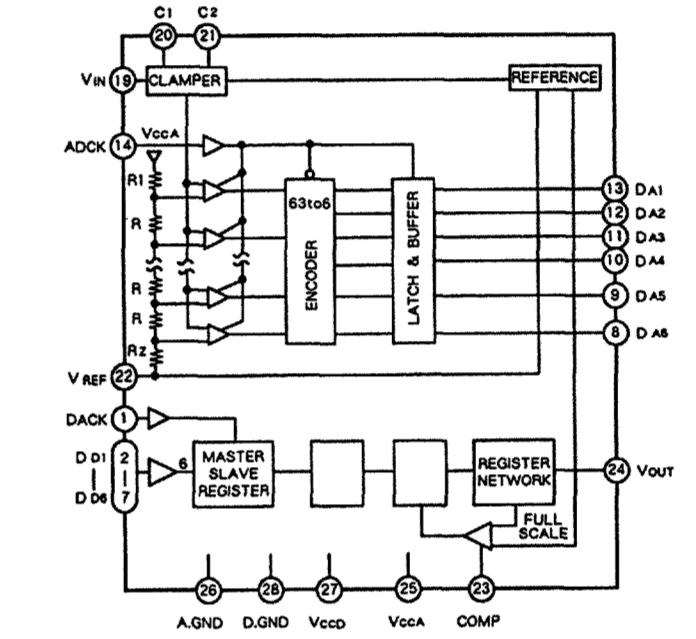

• P BOARD WAVEFORMS

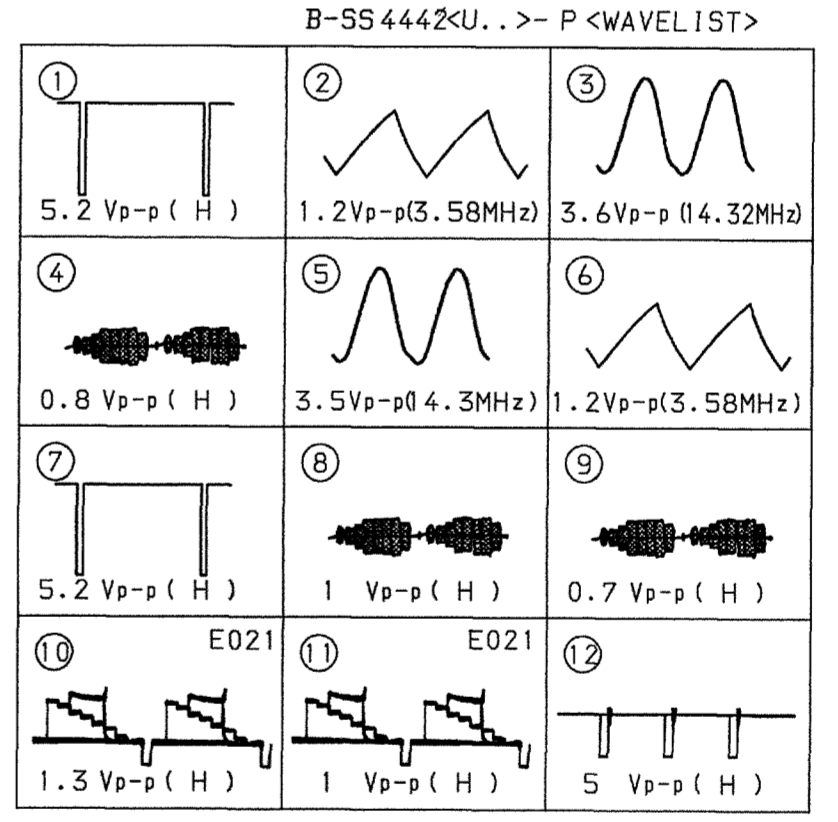

A  
B  
C  
D  
E  
F  
G  
H  
I  
J  
K  
L  
M  
N  
O  
P



**M** Y/C/J CONTROL  
AUDIO CONTROL  
CLOSED CAPTION

— M Board (Conductor Side) —

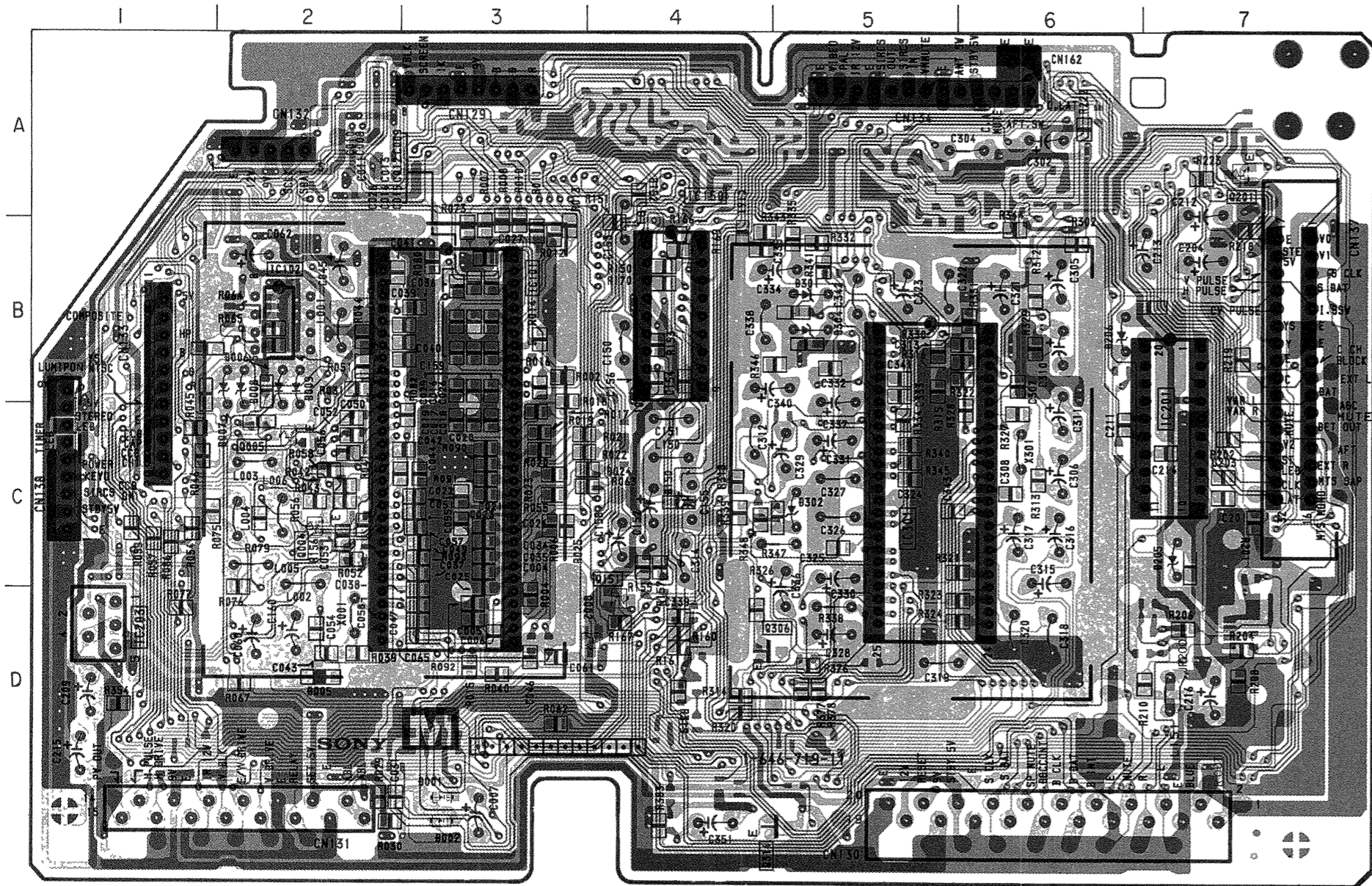

- : Pattern on the side which is seen.
- : Pattern of the rear side.

• M BOARD

IC	(Conductor Side) (Component Side)	
	IC101	C-3
IC102	B-2	B-7
IC150	B-4	B-4
IC201		B-2
IC202		D-1
IC301	B-5	B-3

TRANSISTOR	(Conductor Side) (Component Side)	
	Q001	
Q002	D-4	
Q004	C-2	D-4
Q005	C-2	
Q151	D-4	
Q201	A-7	
Q301		A-2
Q302		A-2
Q307		D-4
Q308		D-3
Q314	D-5	

DIODE	(Conductor Side) (Component Side)	
	D001	D-3
D002	D-3	
D004		D-4
D005	D-2	
D006	B-2	B-6
D007	B-2	B-7
D008	B-2	B-7
D009	B-2	B-6
D150	C-4	
D201		A-1
D202		A-1
D205	C-7	C-2
D206	B-6	B-2
D301	B-5	B-4
D304	B-5	B-4
D305		D-4
D306		D-4

CRYSTAL	(Conductor Side) (Component Side)	
	X001	D-2
X301	C-6	C-2

— M Board (Component Side) —

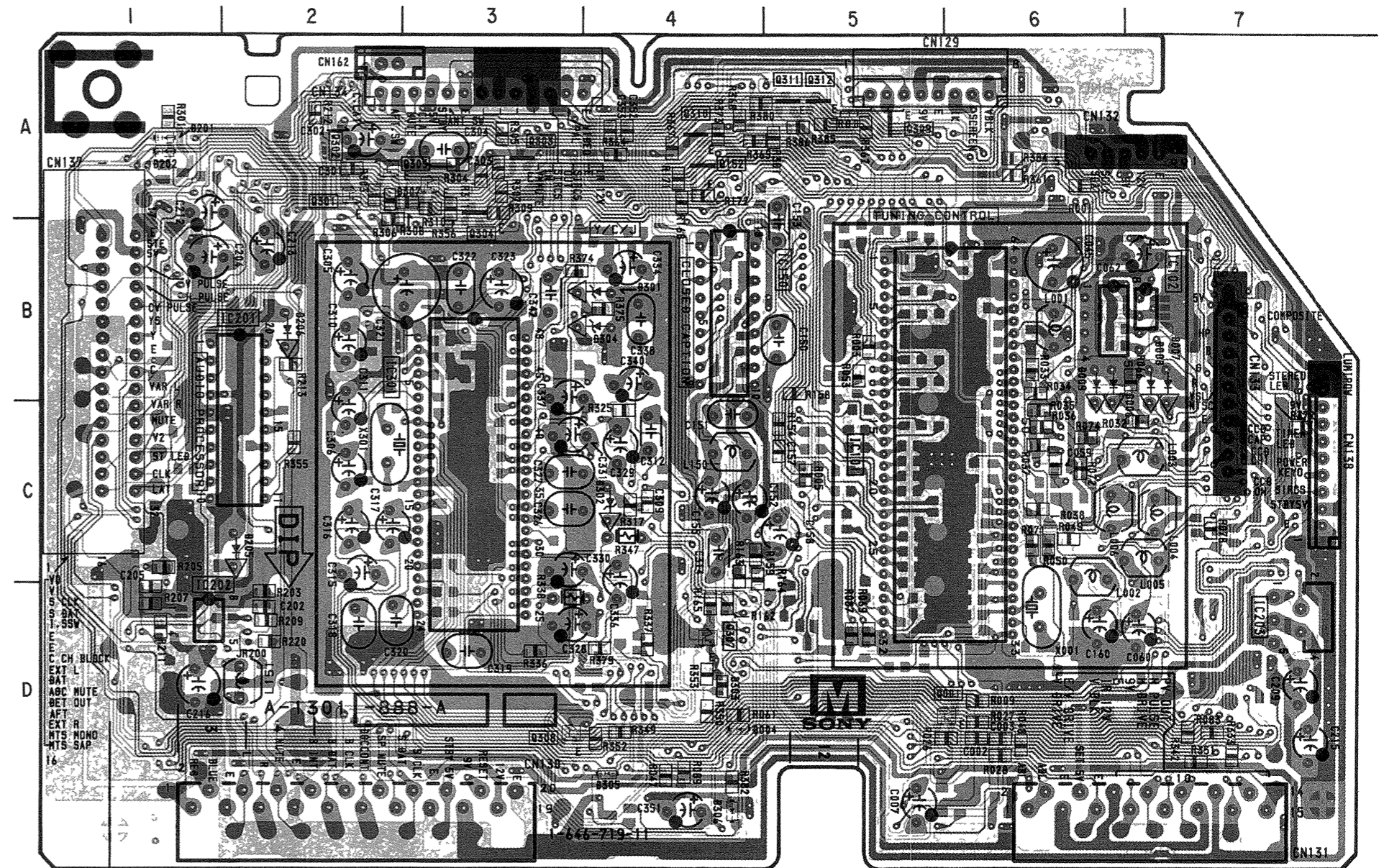

- : Pattern on the side which is seen.
- : Pattern of the rear side.

**6-5. SEMICONDUCTORS**

**CXA1465AS**  
**CXA1545AS**

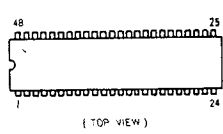

**CXP80424-065S**

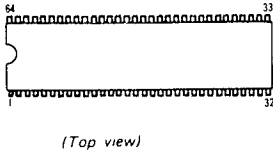

**LM358P**  
**ST24C02AB1**  
 $\mu$  **PC358C**  
 $\mu$  **PC393C**

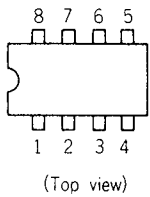

**LM358PS**

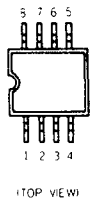

**LM7805CT**  
**LM7812CT**  
**MC7809CT**  
**RC7809FA**

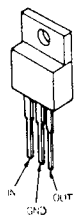

**L78LR05D-MA**



**MB3512PF-EF**

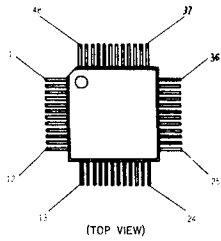

**MB40176PF-G-BND-EF**

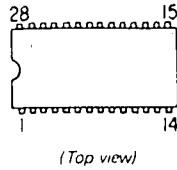

**MB81461B-12RS-PSZ**

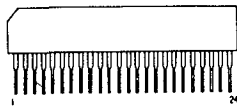

**MB86144**

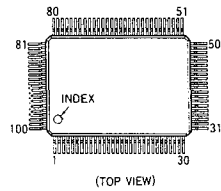

**RC78L05A**  
 $\mu$  **PC78L05J**

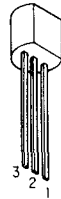

**TDA8172**

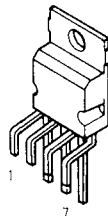

**TDA8424**

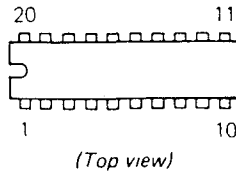

**Z8612812PSC**

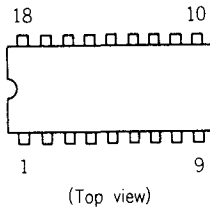

**2SA1091-O**  
**2SA1091-R**

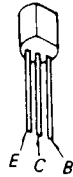

**2SA1175-HFE**  
**2SA1309A**  
**2SC2785-HFE**  
**2SC3311A**

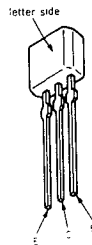

**2SB709A-Q**  
**2SB734-34**  
**2SD601A-Q**  
**2SD774-34**

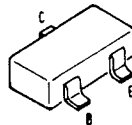

**2SB1370-EF**  
**2SC4159-E**  
**2SD2012**  
**2SD2061-EF**

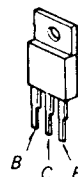

**2SC2688-LK**

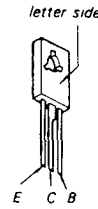

**2SC4834MNP**

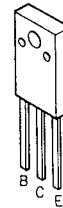

**2SC4927-01**  
**2SC4927-02**

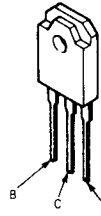

**D1NS4**  
**D1N20R**  
**ERA81-004**  
**ERA82-004**  
**ERA83-006**  
**ERA85-009**  
**RD10ES-B**  
**RD10ES-B2**  
**RD12ES-B3**  
**RD13ES-B2**  
**RD3.6ES-B1**  
**RD33ES-B1**  
**RD5.1ES-B1**  
**RD8.2ES-B3**  
**1SS119**

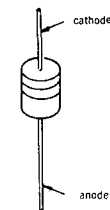

**D2S4M**  
**D2S4MF**

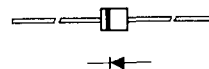

**D5SC4M**  
**D5SC4MR**



**EL1Z**  
**GP08DPKG3**  
**RGP10GPKG3**

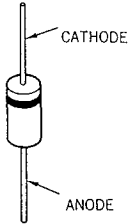

**ERC06-15S**  
**S2L20UF**  
**S3V10SS**

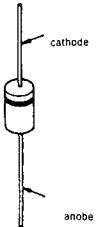

**ERD29-08J**  
**RGPO2-17EL-6433**

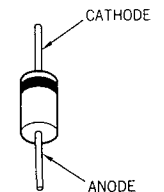

**MA110**

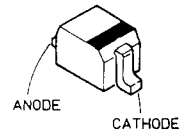

## SECTION 7 EXPLODED VIEWS

**NOTE:**

- Items with no part number and no description are not stocked because they are seldom required for routine service.
- The construction parts of an assembled part are indicated with a collation number in the remark column.
- Items marked "★" are not stocked since they are seldom required for routine service. Some delay should be anticipated when ordering these items.

The components identified by shading and mark **▲** are critical for safety  
Replace only with part number specified

Les composants identifiés par une trame et une marque **▲** sont critiques pour la sécurité  
Ne les remplacer que par une pièce portant le numéro spécifié

### 7-1. CHASSIS

- : BVTP4 × 16 7-685-663-79
- ▲: BVTP4 × 12 7-685-661-14

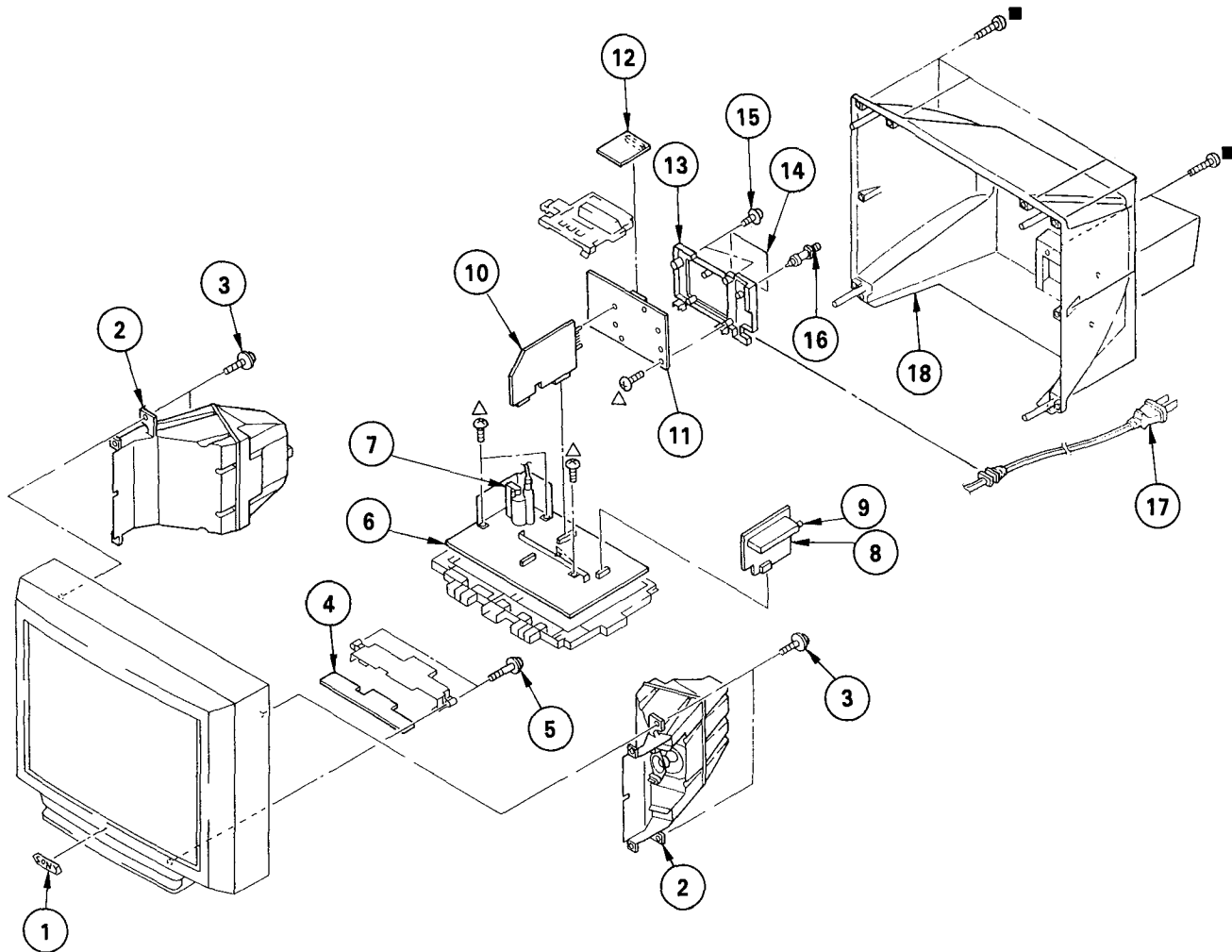

REF. NO.	PART NO.	DESCRIPTION	REMARK	REF. NO.	PART NO.	DESCRIPTION	REMARK
1	4-394-048-01	EMBLEM (NO.9), SONY		10	*A-1306-432-A	M BOARD, COMPLETE	(KV-29V55M (B))
2	1-504-322-11	BOX, SPEAKER (10CM.5CM)		11	*A-1394-418-A	UA BOARD, COMPLETE	
3	4-384-096-01	SCREW (4X16), TAPPING, +P		12	*A-1195-062-A	P BOARD, COMPLETE	
4	*1-646-717-11	H BOARD		13	4-039-524-01	TERMINAL BOARD, ANTENNA	
5	4-319-520-11	SCREW, SPECIAL (+PW4X30)		14	4-040-090-01	LABEL, TERMINAL	
6	*A-1346-116-A	D BOARD, COMPLETE		15	4-382-854-11	SCREW (M3X10), P, SW (+)	
7	▲ 1-453-146-11	TRANSFORMER ASSY, FLYBACK (NX-260443)		16	1-573-657-11	PLUG, F-PIN	
8	*A-1297-065-A	A & B BOARD, COMPLETE		17	▲ 1-751-859-11	CORD, POWER (WITH CONNECTOR) (10A/125V)	
9	▲ 8-598-039-01	TUNER BTF-44401		18	4-040-099-01	COVER, REAR	
10	*A-1306-427-A	M BOARD, COMPLETE	(KV-27V55 (U/C))				

Les composants identifiés par une trame et une marque  $\Delta$  sont critiques pour la sécurité. Ne les remplacer que par une pièce portant le numéro spécifié.

The components identified by shading and mark  $\Delta$  are critical for safety. Replace only with part numbers specified.

**7-2. PICTURE TUBE**

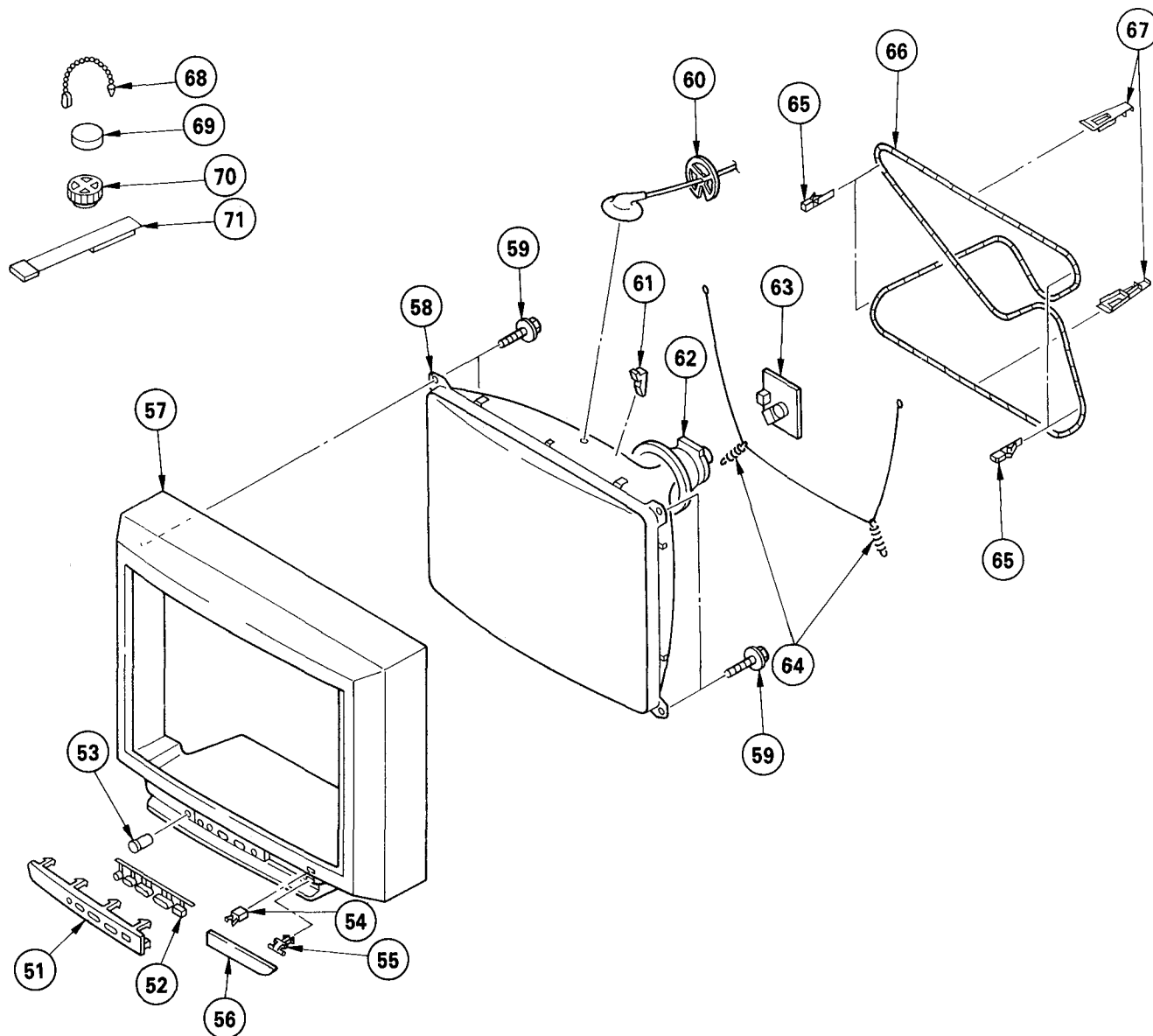

REF. NO.	PART NO.	DESCRIPTION	REMARK	REF. NO.	PART NO.	DESCRIPTION	REMARK
51	4-040-100-01	PANEL, CONTROL		61	3-704-495-01	SPACER, DY	
52	4-039-902-01	BUTTON, MULTI		62	$\Delta$ 1-451-275-41	DEFLECTION YOKE (Y2&PFA)	
53	*4-389-517-01	GUIDE (R), LIGHT		63	*A-1331-270-A	C BOARD, COMPLETE	
54	4-392-036-01	CATCHER, PUSH		64	4-036-329-01	SPRING (B), TENSION	
55	3-703-035-11	SHAFT, LID		65	4-040-388-01	HOLDER (S), DGC	
56	4-040-096-01	DOOR, CONTROL		66	$\Delta$ 1-406-726-11	COIL, DEGAUSSING	
57	X-4031-072-1	BEZEL ASSY		67	4-040-387-01	HOLDER (M), DGC	
58	$\Delta$ 1-733-838-05	PICTURE TUBE (A68XZ350X)		68	4-308-870-00	CLIP, LEAD WIRE	
59	4-390-505-01	SCREW (7), TAPPING		69	1-452-032-00	MAGNET, DISK	
60	*3-704-372-01	HOLDER, HV CABLE		70	1-452-094-00	MAGNET, ROTATABLE DISK; 15MM $\phi$	
				71	X-4306-312-0	PERMALLOY ASSY, CONVERGENCE	

## SECTION 8 ELECTRICAL PARTS LIST

P

**NOTE:**

The components identified by shading and mark **△** are critical for safety  
Replace only with part number specified

Les composants identifiés par une trame e\* une marque **△** sont critiques pour la sécurité  
Ne les remplacer que par une pièce portant le numéro spécifié

• Items marked " \* " are not stocked since they are seldom required for routine service. Some delay should be anticipated when ordering these items.

• All variable and adjustable resistors have characteristic curve B, unless otherwise noted.

**RESISTORS**

• All resistors are in ohms  
• F : nonflammable

When indicating parts by reference number, please include the board name.

**CAPACITORS**

• MF :  $\mu$ F, PF :  $\mu$  $\mu$ F

**COILS**

• MMH : mH, UH :  $\mu$ H

• The components identified by **⊠** in this manual have been carefully factory-selected for each set in order to satisfy regulations regarding X-ray radiation  
Should replacement be required, replace only with the value originally used

REF. NO.	PART NO.	DESCRIPTION	REMARK	REF. NO.	PART NO.	DESCRIPTION	REMARK
*A-1195-062-A		P BOARD, COMPLETE *****		C3249	1-163-117-00	CERAMIC CHIP 100PF	5% 50V
		<CAPACITOR>		C3250	1-163-113-00	CERAMIC CHIP 68PF	5% 50V
C3201	1-124-477-11	ELECT 47MF	20% 16V	C3251	1-164-232-11	CERAMIC CHIP 0.01MF	10% 50V
C3203	1-164-004-11	CERAMIC CHIP 0.1MF	10% 25V	C3252	1-163-103-00	CERAMIC CHIP 27PF	5% 50V
C3204	1-124-907-11	ELECT 10MF	20% 50V	C3253	1-163-101-00	CERAMIC CHIP 22PF	5% 50V
C3205	1-124-907-11	ELECT 10MF	20% 50V	C3254	1-163-141-00	CERAMIC CHIP 0.001MF	5% 50V
C3206	1-124-907-11	ELECT 10MF	20% 50V	C3255	1-163-101-00	CERAMIC CHIP 22PF	5% 50V
C3207	1-163-117-00	CERAMIC CHIP 100PF	5% 50V	C3256	1-164-232-11	CERAMIC CHIP 0.01MF	10% 50V
C3208	1-163-117-00	CERAMIC CHIP 100PF	5% 50V	C3257	1-163-117-00	CERAMIC CHIP 100PF	5% 50V
C3209	1-123-382-00	ELECT 3.3MF	20% 50V	C3258	1-163-113-00	CERAMIC CHIP 68PF	5% 50V
C3210	1-124-477-11	ELECT 47MF	20% 16V	C3259	1-163-111-00	CERAMIC CHIP 56PF	5% 50V
C3212	1-123-382-00	ELECT 3.3MF	20% 50V	C3260	1-163-119-00	CERAMIC CHIP 120PF	5% 50V
C3213	1-164-346-11	CERAMIC CHIP 1MF	16V	C3261	1-163-141-00	CERAMIC CHIP 0.001MF	5% 50V
C3214	1-164-346-11	CERAMIC CHIP 1MF	16V	C3263	1-163-141-00	CERAMIC CHIP 0.001MF	5% 50V
C3215	1-164-346-11	CERAMIC CHIP 1MF	16V	C3264	1-165-319-11	CERAMIC CHIP 0.1MF	50V
C3216	1-164-005-11	CERAMIC CHIP 0.47MF	25V	C3265	1-163-141-00	CERAMIC CHIP 0.001MF	5% 50V
C3217	1-164-346-11	CERAMIC CHIP 1MF	16V	C3266	1-163-141-00	CERAMIC CHIP 0.001MF	5% 50V
C3218	1-164-346-11	CERAMIC CHIP 1MF	16V	C3267	1-163-141-00	CERAMIC CHIP 0.001MF	5% 50V
C3219	1-126-103-11	ELECT 470MF	20% 16V	C3268	1-163-141-00	CERAMIC CHIP 0.001MF	5% 50V
C3220	1-164-346-11	CERAMIC CHIP 1MF	16V	C3269	1-163-141-00	CERAMIC CHIP 0.001MF	5% 50V
C3221	1-164-346-11	CERAMIC CHIP 1MF	16V	C3270	1-165-319-11	CERAMIC CHIP 0.1MF	50V
C3222	1-164-336-11	CERAMIC CHIP 0.33MF	25V	C3271	1-165-319-11	CERAMIC CHIP 0.1MF	50V
C3223	1-164-336-11	CERAMIC CHIP 0.33MF	25V	C3272	1-165-319-11	CERAMIC CHIP 0.1MF	50V
C3224	1-164-222-11	CERAMIC CHIP 0.22MF	25V	C3273	1-163-109-00	CERAMIC CHIP 47PF	5% 50V
C3225	1-164-222-11	CERAMIC CHIP 0.22MF	25V	C3274	1-163-101-00	CERAMIC CHIP 22PF	5% 50V
C3226	1-164-005-11	CERAMIC CHIP 0.47MF	25V	C3275	1-163-101-00	CERAMIC CHIP 22PF	5% 50V
C3227	1-164-346-11	CERAMIC CHIP 1MF	16V	C3276	1-163-111-00	CERAMIC CHIP 56PF	5% 50V
C3228	1-163-117-00	CERAMIC CHIP 100PF	5% 50V	C3277	1-163-101-00	CERAMIC CHIP 22PF	5% 50V
C3229	1-163-093-00	CERAMIC CHIP 10PF	5% 50V	C3278	1-163-101-00	CERAMIC CHIP 22PF	5% 50V
C3230	1-163-141-00	CERAMIC CHIP 0.001MF	5% 50V	C3279	1-163-141-00	CERAMIC CHIP 0.001MF	5% 50V
C3231	1-163-125-00	CERAMIC CHIP 220PF	5% 50V	C3280	1-124-907-11	ELECT 10MF	20% 50V
C3232	1-163-117-00	CERAMIC CHIP 100PF	5% 50V	C3282	1-164-346-11	CERAMIC CHIP 1MF	16V
C3233	1-164-232-11	CERAMIC CHIP 0.01MF	10% 50V			<CONNECTOR>	
C3234	1-164-232-11	CERAMIC CHIP 0.01MF	10% 50V	CN150	1-573-297-11	CONNECTOR, BOARD TO BOARD 18P	
C3235	1-164-232-11	CERAMIC CHIP 0.01MF	10% 50V			<DIODE>	
C3236	1-164-232-11	CERAMIC CHIP 0.01MF	10% 50V	D3202	8-719-031-68	DIODE HVU359TRF	
C3237	1-164-232-11	CERAMIC CHIP 0.01MF	10% 50V	D3203	8-719-404-46	DIODE MA110	
C3238	1-163-101-00	CERAMIC CHIP 22PF	5% 50V	D3208	8-719-110-17	DIODE RD10ESB2	
C3239	1-163-141-00	CERAMIC CHIP 0.001MF	5% 50V	D3209	8-719-110-17	DIODE RD10ESB2	
C3240	1-163-101-00	CERAMIC CHIP 22PF	5% 50V			<IC>	
C3241	1-163-103-00	CERAMIC CHIP 27PF	5% 50V	IC3200	8-759-971-56	IC MB81461B-12RS-PSZ	
C3242	1-164-232-11	CERAMIC CHIP 0.01MF	10% 50V	IC3201	8-759-093-29	IC MB86144B	
C3243	1-163-117-00	CERAMIC CHIP 100PF	5% 50V	IC3202	8-759-093-28	IC MB40176PF-EF	
C3244	1-163-113-00	CERAMIC CHIP 68PF	5% 50V	IC3203	8-759-093-28	IC MB40176PF-EF	
C3245	1-164-232-11	CERAMIC CHIP 0.01MF	10% 50V	IC3204	8-759-093-26	IC MB3512PF-EF	
C3246	1-164-232-11	CERAMIC CHIP 0.01MF	10% 50V				
C3247	1-163-033-00	CERAMIC CHIP 0.022MF	50V				
C3248	1-163-125-00	CERAMIC CHIP 220PF	5% 50V				



REF. NO.	PART NO.	DESCRIPTION	REMARK
IC3205	8-759-243-19	IC TC7SU04F	
<COIL>			
L3201	1-410-470-11	INDUCTOR 10UH	
L3202	1-408-424-00	INDUCTOR 180UH	
L3203	1-408-424-00	INDUCTOR 180UH	
L3204	1-410-476-11	INDUCTOR 33UH	
L3205	1-410-470-11	INDUCTOR 10UH	
L3206	1-410-387-11	INDUCTOR 33UH	
L3207	1-410-387-11	INDUCTOR 33UH	
L3208	1-410-387-11	INDUCTOR 33UH	
L3209	1-410-387-11	INDUCTOR 33UH	
<TRANSISTOR>			
Q3201	8-729-422-36	TRANSISTOR 2SB709A-Q	
Q3202	8-729-422-27	TRANSISTOR 2SD601A-Q	
Q3203	8-729-422-36	TRANSISTOR 2SB709A-Q	
Q3204	8-729-422-36	TRANSISTOR 2SB709A-Q	
Q3206	8-729-422-27	TRANSISTOR 2SD601A-Q	
Q3207	8-729-422-36	TRANSISTOR 2SB709A-Q	
Q3208	8-729-422-27	TRANSISTOR 2SD601A-Q	
Q3209	8-729-422-36	TRANSISTOR 2SB709A-Q	
Q3210	8-729-422-36	TRANSISTOR 2SB709A-Q	
<RESISTOR>			
R3201	1-216-097-00	METAL GLAZE 100K 5%	1/10W
R3202	1-216-073-00	METAL GLAZE 10K 5%	1/10W
R3203	1-216-025-00	METAL GLAZE 100 5%	1/10W
R3204	1-216-025-00	METAL GLAZE 100 5%	1/10W
R3205	1-216-121-00	METAL GLAZE 1M 5%	1/10W
R3207	1-216-295-00	METAL GLAZE 0 5%	1/10W
R3208	1-216-097-00	METAL GLAZE 100K 5%	1/10W
R3209	1-216-079-00	METAL GLAZE 18K 5%	1/10W
R3210	1-216-089-00	METAL GLAZE 47K 5%	1/10W
R3211	1-216-073-00	METAL GLAZE 10K 5%	1/10W
R3212	1-216-073-00	METAL GLAZE 10K 5%	1/10W
R3213	1-216-075-00	METAL GLAZE 12K 5%	1/10W
R3214	1-216-121-00	METAL GLAZE 1M 5%	1/10W
R3215	1-216-057-00	METAL GLAZE 2.2K 5%	1/10W
R3216	1-216-057-00	METAL GLAZE 2.2K 5%	1/10W
R3217	1-216-057-00	METAL GLAZE 2.2K 5%	1/10W
R3218	1-216-049-00	METAL GLAZE 1K 5%	1/10W
R3219	1-216-049-00	METAL GLAZE 1K 5%	1/10W
R3220	1-216-049-00	METAL GLAZE 1K 5%	1/10W
R3221	1-216-655-11	METAL CHIP 1.5K 0.50%	1/10W
R3222	1-216-655-11	METAL CHIP 1.5K 0.50%	1/10W
R3223	1-216-025-00	METAL GLAZE 100 5%	1/10W
R3224	1-216-049-00	METAL GLAZE 1K 5%	1/10W
R3225	1-216-025-00	METAL GLAZE 100 5%	1/10W
R3226	1-216-085-00	METAL GLAZE 33K 5%	1/10W
R3227	1-216-647-11	METAL CHIP 680 0.50%	1/10W
R3228	1-216-045-00	METAL GLAZE 680 5%	1/10W
R3229	1-216-073-00	METAL GLAZE 10K 5%	1/10W
R3230	1-216-073-00	METAL GLAZE 10K 5%	1/10W
R3231	1-216-001-00	METAL GLAZE 10 5%	1/10W
R3232	1-216-083-00	METAL GLAZE 27K 5%	1/10W
R3233	1-216-049-00	METAL GLAZE 1K 5%	1/10W
R3234	1-216-651-11	METAL CHIP 1K 0.50%	1/10W
R3235	1-216-043-00	METAL GLAZE 560 5%	1/10W
R3236	1-216-065-00	METAL GLAZE 4.7K 5%	1/10W
R3237	1-216-043-00	METAL GLAZE 560 5%	1/10W

REF. NO.	PART NO.	DESCRIPTION	REMARK
R3238	1-216-049-00	METAL GLAZE 1K 5%	1/10W
R3239	1-216-043-00	METAL GLAZE 560 5%	1/10W
R3241	1-216-057-00	METAL GLAZE 2.2K 5%	1/10W
R3242	1-216-049-00	METAL GLAZE 1K 5%	1/10W
R3243	1-216-025-00	METAL GLAZE 100 5%	1/10W
R3244	1-216-025-00	METAL GLAZE 100 5%	1/10W
R3245	1-216-025-00	METAL GLAZE 100 5%	1/10W
R3246	1-216-069-00	METAL GLAZE 6.8K 5%	1/10W
R3247	1-216-063-00	METAL GLAZE 3.9K 5%	1/10W
R3248	1-216-295-00	METAL GLAZE 0 5%	1/10W
R3249	1-216-057-00	METAL GLAZE 2.2K 5%	1/10W
R3250	1-216-043-00	METAL GLAZE 560 5%	1/10W
R3251	1-216-049-00	METAL GLAZE 1K 5%	1/10W
R3252	1-216-043-00	METAL GLAZE 560 5%	1/10W
R3253	1-216-065-00	METAL GLAZE 4.7K 5%	1/10W
R3254	1-216-043-00	METAL GLAZE 560 5%	1/10W
R3255	1-216-041-00	METAL GLAZE 470 5%	1/10W
R3256	1-216-043-00	METAL GLAZE 560 5%	1/10W
R3259	1-216-298-00	METAL GLAZE 2.2 5%	1/10W
R3260	1-216-073-00	METAL GLAZE 10K 5%	1/10W
R3263	1-216-025-00	METAL GLAZE 100 5%	1/10W
R3264	1-216-025-00	METAL GLAZE 100 5%	1/10W
R3265	1-216-049-00	METAL GLAZE 1K 5%	1/10W
R3266	1-216-057-00	METAL GLAZE 2.2K 5%	1/10W
R3267	1-216-055-00	METAL GLAZE 1.8K 5%	1/10W
R3268	1-216-053-00	METAL GLAZE 1.5K 5%	1/10W
R3269	1-216-057-00	METAL GLAZE 2.2K 5%	1/10W
R3270	1-216-657-11	METAL CHIP 1.8K 0.50%	1/10W
R3271	1-216-655-11	METAL CHIP 1.5K 0.50%	1/10W
R3273	1-216-073-00	METAL GLAZE 10K 5%	1/10W
R3274	1-216-049-00	METAL GLAZE 1K 5%	1/10W
R3275	1-216-049-00	METAL GLAZE 1K 5%	1/10W
R3276	1-216-049-00	METAL GLAZE 1K 5%	1/10W
R3277	1-216-298-00	METAL GLAZE 2.2 5%	1/10W
<CRYSTAL>			
X3201	1-567-878-11	VIBRATOR, CRYSTAL	
X3202	1-567-878-11	VIBRATOR, CRYSTAL	
*****			
*A-1297-065-A A BOARD, COMPLETE *****			
<CAPACITOR>			
C173	1-164-232-11	CERAMIC CHIP 0.01MF	10% 50V
C174	1-164-232-11	CERAMIC CHIP 0.01MF	10% 50V
C175	1-126-103-11	ELECT 470MF	20% 16V
C176	1-126-103-11	ELECT 470MF	20% 16V
C177	1-124-907-11	ELECT 10MF	20% 50V
C178	1-126-101-11	ELECT 100MF	20% 16V
C179	1-124-916-11	ELECT 22MF	20% 25V
C181	1-164-161-11	CERAMIC CHIP 0.0022MF	10% 50V
<CONNECTOR>			
CN103	*1-564-519-11	PLUG, CONNECTOR 4P	
CN151	*1-573-979-11	CONNECTOR, BOARD TO BOARD 11P	
CN152	1-750-394-11	PIN, CONNECTOR (STAKING) 32P	
CN164	*1-564-505-11	PLUG, CONNECTOR 2P	
CN165	*1-564-505-11	PLUG, CONNECTOR 2P	
<DIODE>			

The components identified by shading and mark  $\Delta$  are critical for safety  
Replace only with part number specified

Les composants identifiés par une trame et une marque  $\Delta$  sont critiques pour la sécurité  
Ne les remplacer que par une pièce portant le numéro spécifique



REF. NO.	PART NO.	DESCRIPTION	REMARK	REF. NO.	PART NO.	DESCRIPTION	REMARK
D170	8-719-110-76	DIODE RD33ESB1		C055	1-163-125-00	CERAMIC CHIP 220PF	5% 50V
		<COIL>		C056	1-163-125-00	CERAMIC CHIP 220PF	5% 50V
L170	1-408-408-00	INDUCTOR 8.2UH		C057	1-163-017-00	CERAMIC CHIP 0.0047MF	10% 50V
L171	1-408-408-00	INDUCTOR 8.2UH		C058	1-163-037-11	CERAMIC CHIP 0.022MF	10% 25V
L172	1-408-408-00	INDUCTOR 8.2UH		C059	1-163-125-00	CERAMIC CHIP 220PF	5% 50V
		<RESISTOR>		C060	1-124-903-11	ELECT 1MF	20% 50V
R170	1-216-025-00	METAL GLAZE 100 5% 1/10W		C061	1-163-117-00	CERAMIC CHIP 100PF	5% 50V
R174	1-216-689-11	METAL GLAZE 39K 5% 1/10W		C062	1-124-907-11	ELECT 10MF	20% 50V
R176	1-216-295-00	METAL GLAZE 0 5% 1/10W		C150	1-136-165-00	FILM 0.1MF	5% 50V
R177	1-215-900-11	METAL OXIDE 22K 5% 2W $\Delta$		C151	1-136-175-00	FILM 0.068MF	5% 50V
R179	1-216-065-00	METAL GLAZE 4.7K 5% 1/10W		C152	1-124-907-11	ELECT 10MF	20% 50V
R187	1-216-083-00	METAL GLAZE 27K 5% 1/10W		C153	1-137-367-11	FILM 0.0033MF	5% 50V
R193	1-216-037-00	METAL GLAZE 330 5% 1/10W		C154	1-163-038-00	CERAMIC CHIP 0.1MF	25V
		<TUNER>		C155	1-124-907-11	ELECT 10MF	20% 50V
TU101A	8-598-039-01	TUNER STP-WA401		C156	1-163-135-00	CERAMIC CHIP 560PF	5% 50V
*****							
	*A-1306-427-A	M BOARD, COMPLETE (KV-27V55 (U/C))		C157	1-163-038-00	CERAMIC CHIP 0.1MF	25V
	*A-1306-432-A	M BOARD, COMPLETE (KV-29V55M (B))		C158	1-124-903-11	ELECT 1MF	20% 50V
		<CAPACITOR>		C160	1-124-903-11	ELECT 1MF	20% 50V
C002	1-163-809-11	CERAMIC CHIP 0.047MF	10% 25V	C201	1-163-017-00	CERAMIC CHIP 0.0047MF	10% 50V
C003	1-163-001-11	CERAMIC CHIP 220PF	10% 50V	C202	1-163-125-00	CERAMIC CHIP 220PF	5% 50V
C005	1-163-125-00	CERAMIC CHIP 220PF	5% 50V	C203	1-163-989-11	CERAMIC CHIP 0.033MF	10% 25V
C006	1-163-125-00	CERAMIC CHIP 220PF	5% 50V	C204	1-126-101-11	ELECT 100MF	20% 16V
C007	1-124-903-11	ELECT 1MF	20% 50V	C205	1-163-125-00	CERAMIC CHIP 220PF	5% 50V
C008	1-163-125-00	CERAMIC CHIP 220PF	5% 50V	C211	1-163-989-11	CERAMIC CHIP 0.033MF	10% 25V
C009	1-163-125-00	CERAMIC CHIP 220PF	5% 50V	C212	1-124-902-00	ELECT 0.47MF	20% 50V
C010	1-163-125-00	CERAMIC CHIP 220PF	5% 50V	C213	1-124-902-00	ELECT 0.47MF	20% 50V
C012	1-163-125-00	CERAMIC CHIP 220PF	5% 50V	C214	1-163-017-00	CERAMIC CHIP 0.0047MF	10% 50V
C013	1-163-125-00	CERAMIC CHIP 220PF	5% 50V	C216	1-124-478-11	ELECT 100MF	20% 25V
C014	1-163-125-00	CERAMIC CHIP 220PF	5% 50V	C301	1-163-117-00	CERAMIC CHIP 100PF	5% 50V
C015	1-163-125-00	CERAMIC CHIP 220PF	5% 50V	C305	1-124-907-11	ELECT 10MF	20% 50V
C016	1-163-125-00	CERAMIC CHIP 220PF	5% 50V	C306	1-124-902-00	ELECT 0.47MF	20% 50V
C017	1-163-125-00	CERAMIC CHIP 220PF	5% 50V	C307	1-163-125-00	CERAMIC CHIP 220PF	5% 50V
C018	1-163-125-00	CERAMIC CHIP 220PF	5% 50V	C308	1-163-099-00	CERAMIC CHIP 18PF	5% 50V
C019	1-163-125-00	CERAMIC CHIP 220PF	5% 50V	C310	1-124-916-11	ELECT 22MF	20% 25V
C021	1-163-125-00	CERAMIC CHIP 220PF	5% 50V	C311	1-124-903-11	ELECT 1MF	20% 50V
C022	1-163-125-00	CERAMIC CHIP 220PF	5% 50V	C313	1-163-003-11	CERAMIC CHIP 330PF	10% 50V
C023	1-163-125-00	CERAMIC CHIP 220PF	5% 50V	C315	1-124-907-11	ELECT 10MF	20% 50V
C025	1-163-125-00	CERAMIC CHIP 220PF	5% 50V	C316	1-124-907-11	ELECT 10MF	20% 50V
C028	1-163-125-00	CERAMIC CHIP 220PF	5% 50V	C317	1-124-907-11	ELECT 10MF	20% 50V
C029	1-163-125-00	CERAMIC CHIP 220PF	5% 50V	C318	1-136-165-00	FILM 0.1MF	5% 50V
C041	1-163-009-11	CERAMIC CHIP 0.001MF	10% 50V	C319	1-136-165-00	FILM 0.1MF	5% 50V
C043	1-163-159-00	CERAMIC CHIP 12PF	2% 50V	C320	1-136-165-00	FILM 0.1MF	5% 50V
C045	1-124-119-00	ELECT 330MF	20% 16V	C321	1-124-360-00	ELECT 1000MF	20% 16V
C047	1-104-896-91	CERAMIC CHIP 24PF	2% 50V	C322	1-136-153-00	FILM 0.01MF	5% 50V
C049	1-163-125-00	CERAMIC CHIP 220PF	5% 50V	C323	1-126-176-11	ELECT 220MF	20% 10V
C050	1-163-125-00	CERAMIC CHIP 220PF	5% 50V	C324	1-163-003-11	CERAMIC CHIP 330PF	10% 50V
C051	1-163-031-11	CERAMIC CHIP 0.01MF	5% 50V	C325	1-163-037-11	CERAMIC CHIP 0.022MF	10% 25V
C052	1-163-125-00	CERAMIC CHIP 220PF	5% 50V	C326	1-136-169-00	FILM 0.22MF	5% 50V
C053	1-163-121-00	CERAMIC CHIP 150PF	5% 50V	C327	1-136-169-00	FILM 0.22MF	5% 50V
C054	1-163-125-00	CERAMIC CHIP 220PF	5% 50V	C328	1-124-902-00	ELECT 0.47MF	20% 50V
				C329	1-124-903-11	ELECT 1MF	20% 50V
				C330	1-124-907-11	ELECT 10MF	20% 50V



REF. NO.	PART NO.	DESCRIPTION	REMARK	REF. NO.	PART NO.	DESCRIPTION	REMARK
C331	1-124-907-11	ELECT 10MF	20% 50V	Q151	8-729-422-27	TRANSISTOR 2SD601A-Q	(KV-27V55 (U/C))
C332	1-164-489-11	CERAMIC CHIP 0.22MF	10% 16V	Q201	8-729-422-27	TRANSISTOR 2SD601A-Q	
C333	1-163-011-11	CERAMIC CHIP 0.0015MF	10% 50V	Q301	8-729-422-36	TRANSISTOR 2SB709A-Q	
C334	1-124-902-00	ELECT 0.47MF	20% 50V	Q302	8-729-422-36	TRANSISTOR 2SB709A-Q	
C335	1-163-001-11	CERAMIC CHIP 220PF	10% 50V	Q307	8-729-422-27	TRANSISTOR 2SD601A-Q	
C336	1-124-903-11	ELECT 1MF	20% 50V	Q308	8-729-422-27	TRANSISTOR 2SD601A-Q	
C337	1-124-902-00	ELECT 0.47MF	20% 50V				
C338	1-136-153-00	FILM 0.01MF	5% 50V				
C340	1-124-903-11	ELECT 1MF	20% 50V				
C341	1-163-005-11	CERAMIC CHIP 470PF	10% 50V				
C342	1-137-414-91	FILM 0.0047MF	10% 100V				
		<CONNECTOR>					
CN129	*1-564-523-11	PLUG, CONNECTOR 8P		R002	1-216-073-00	METAL GLAZE 10K 5%	1/10W
CN130	1-573-301-11	CONNECTOR, BOARD TO BOARD 20P		R003	1-216-033-00	METAL GLAZE 220 5%	1/10W
CN131	*1-691-632-11	CONNECTOR, BOARD TO BOARD 15P		R004	1-216-033-00	METAL GLAZE 220 5%	1/10W
CN137	1-750-394-11	PIN, CONNECTOR (STAKING) 32P		R005	1-216-033-00	METAL GLAZE 220 5%	1/10W
CN138	*1-564-511-11	PLUG, CONNECTOR 8P		R006	1-216-049-00	METAL GLAZE 1K 5%	1/10W
CN168	*1-564-505-11	PLUG, CONNECTOR 2P		R007	1-216-033-00	METAL GLAZE 220 5%	1/10W
		<DIODE>		R008	1-216-033-00	METAL GLAZE 220 5%	1/10W
D001	8-719-404-46	DIODE MA110		R009	1-216-033-00	METAL GLAZE 220 5%	1/10W
D002	8-719-404-46	DIODE MA110	(KV-27V55 (U/C))	R011	1-216-033-00	METAL GLAZE 220 5%	1/10W
D004	8-719-404-46	DIODE MA110		R012	1-216-033-00	METAL GLAZE 220 5%	1/10W
D005	8-713-300-57	DIODE 1T33		R013	1-216-033-00	METAL GLAZE 220 5%	1/10W
D006	8-719-110-17	DIODE RD10ESB2		R016	1-216-033-00	METAL GLAZE 220 5%	1/10W
D007	8-719-110-17	DIODE RD10ESB2		R017	1-216-033-00	METAL GLAZE 220 5%	1/10W
D008	8-719-110-17	DIODE RD10ESB2		R018	1-216-033-00	METAL GLAZE 220 5%	1/10W
D009	8-719-110-17	DIODE RD10ESB2		R019	1-216-033-00	METAL GLAZE 220 5%	1/10W
D150	8-719-404-46	DIODE MA110	(KV-27V55 (U/C))	R020	1-216-033-00	METAL GLAZE 220 5%	1/10W
D201	8-719-404-46	DIODE MA110		R021	1-216-073-00	METAL GLAZE 10K 5%	1/10W
D202	8-719-404-46	DIODE MA110		R022	1-216-073-00	METAL GLAZE 10K 5%	1/10W
D205	8-719-110-17	DIODE RD10ESB2		R023	1-216-033-00	METAL GLAZE 220 5%	1/10W
D206	8-719-110-17	DIODE RD10ESB2		R025	1-216-033-00	METAL GLAZE 220 5%	1/10W
D301	8-719-110-17	DIODE RD10ESB2		R026	1-216-097-00	METAL GLAZE 100K 5%	1/10W
D304	8-719-110-17	DIODE RD10ESB2		R027	1-216-121-00	METAL GLAZE 1M 5%	1/10W
		<IC>		R028	1-216-073-00	METAL GLAZE 10K 5%	1/10W
IC101	8-752-841-16	IC CXP80424-065S		R029	1-216-065-00	METAL GLAZE 4.7K 5%	1/10W
IC102	8-759-043-86	IC ST24C02AB1		R030	1-216-073-00	METAL GLAZE 10K 5%	1/10W
IC150	8-759-084-09	IC Z8612812PSC	(KV-27V55 (U/C))	R031	1-216-033-00	METAL GLAZE 220 5%	1/10W
IC201	8-759-090-21	IC TDA8424		R032	1-216-033-00	METAL GLAZE 220 5%	1/10W
IC202	8-759-983-69	IC LM358PS		R033	1-216-033-00	METAL GLAZE 220 5%	1/10W
IC301	8-752-059-67	IC CXA1465AS		R034	1-216-033-00	METAL GLAZE 220 5%	1/10W
		<JUMPER RESISTOR>		R035	1-216-033-00	METAL GLAZE 220 5%	1/10W
JR200	1-216-295-00	METAL GLAZE 0 5%	1/10W	R036	1-216-033-00	METAL GLAZE 220 5%	1/10W
		<COIL>		R037	1-216-033-00	METAL GLAZE 220 5%	1/10W
L001	1-410-470-11	INDUCTOR 10UH		R038	1-216-033-00	METAL GLAZE 220 5%	1/10W
L002	1-408-414-00	INDUCTOR 27UH		R039	1-216-295-00	METAL GLAZE 0 5%	1/10W
L150	1-410-470-11	INDUCTOR 10UH	(KV-27V55 (U/C))	R040	1-216-049-00	METAL GLAZE 1K 5%	1/10W
		<TRANSISTOR>		R041	1-216-033-00	METAL GLAZE 220 5%	1/10W
Q001	8-729-422-36	TRANSISTOR 2SB709A-Q		R042	1-216-049-00	METAL GLAZE 1K 5%	1/10W
Q002	8-729-422-36	TRANSISTOR 2SB709A-Q		R043	1-216-049-00	METAL GLAZE 1K 5%	1/10W
Q004	8-729-422-36	TRANSISTOR 2SB709A-Q		R044	1-216-065-00	METAL GLAZE 4.7K 5%	1/10W
Q005	8-729-422-27	TRANSISTOR 2SD601A-Q		R045	1-216-065-00	METAL GLAZE 4.7K 5%	1/10W
				R046	1-216-065-00	METAL GLAZE 4.7K 5%	1/10W
				R047	1-216-065-00	METAL GLAZE 4.7K 5%	1/10W
				R048	1-216-073-00	METAL GLAZE 10K 5%	1/10W
				R049	1-216-049-00	METAL GLAZE 1K 5%	1/10W
				R050	1-216-049-00	METAL GLAZE 1K 5%	1/10W
				R051	1-216-073-00	METAL GLAZE 10K 5%	1/10W
				R052	1-216-065-00	METAL GLAZE 4.7K 5%	1/10W
				R053	1-216-049-00	METAL GLAZE 1K 5%	1/10W
				R054	1-216-049-00	METAL GLAZE 1K 5%	1/10W
				R058	1-216-073-00	METAL GLAZE 10K 5%	1/10W
				R059	1-216-065-00	METAL GLAZE 4.7K 5%	1/10W
				R061	1-216-077-00	METAL GLAZE 15K 5%	1/10W
				R062	1-216-057-00	METAL GLAZE 2.2K 5%	1/10W
				R064	1-216-065-00	METAL GLAZE 4.7K 5%	1/10W
				R065	1-216-065-00	METAL GLAZE 4.7K 5%	1/10W



REF. NO.	PART NO.	DESCRIPTION	REMARK	REF. NO.	PART NO.	DESCRIPTION	REMARK
R066	1-216-025-00	METAL GLAZE	100 5% 1/10W	R222	1-216-089-00	METAL GLAZE	47K 5% 1/10W
R067	1-216-025-00	METAL GLAZE	100 5% 1/10W	R223	1-216-045-00	METAL GLAZE	680 5% 1/10W
R074	1-216-295-00	METAL GLAZE	0 5% 1/10W	R301	1-216-025-00	METAL GLAZE	100 5% 1/10W
R075	1-216-295-00	METAL GLAZE	0 5% 1/10W	R302	1-216-049-00	METAL GLAZE	1K 5% 1/10W
R076	1-216-295-00	METAL GLAZE	0 5% 1/10W	R303	1-216-065-00	METAL GLAZE	4.7K 5% 1/10W
R078	1-216-073-00	METAL GLAZE	10K 5% 1/10W	R306	1-216-057-00	METAL GLAZE	2.2K 5% 1/10W
R079	1-216-295-00	METAL GLAZE	0 5% 1/10W	R312	1-216-119-00	METAL GLAZE	820K 5% 1/10W
R080	1-216-073-00	METAL GLAZE	10K 5% 1/10W	R313	1-216-079-00	METAL GLAZE	18K 5% 1/10W
R082	1-216-073-00	METAL GLAZE	10K 5% 1/10W	R321	1-216-041-00	METAL GLAZE	470 5% 1/10W
R083	1-216-089-00	METAL GLAZE	47K 5% 1/10W	R323	1-216-041-00	METAL GLAZE	470 5% 1/10W
R086	1-216-089-00	METAL GLAZE	47K 5% 1/10W	R324	1-216-041-00	METAL GLAZE	470 5% 1/10W
R087	1-216-049-00	METAL GLAZE	1K 5% 1/10W	R327	1-216-653-11	METAL CHIP	1.2K 0.50% 1/10W
R089	1-216-083-00	METAL GLAZE	27K 5% 1/10W	R328	1-216-033-00	METAL GLAZE	220 5% 1/10W
R090	1-216-073-00	METAL GLAZE	10K 5% 1/10W	R329	1-216-033-00	METAL GLAZE	220 5% 1/10W
R091	1-216-073-00	METAL GLAZE	10K 5% 1/10W	R330	1-216-295-00	METAL GLAZE	0 5% 1/10W
R092	1-216-073-00	METAL GLAZE	10K 5% 1/10W	R331	1-216-678-11	METAL CHIP	13K 0.50% 1/10W
R093	1-216-295-00	METAL GLAZE	0 5% 1/10W	R332	1-216-057-00	METAL GLAZE	2.2K 5% 1/10W
R150	1-216-097-00	METAL GLAZE	100K 5% 1/10W (KV-27V55 (U/C))	R333	1-216-025-00	METAL GLAZE	100 5% 1/10W
R151	1-216-049-00	METAL GLAZE	1K 5% 1/10W (KV-27V55 (U/C))	R334	1-216-687-11	METAL CHIP	33K 0.50% 1/10W
R152	1-216-049-00	METAL GLAZE	1K 5% 1/10W (KV-27V55 (U/C))	R335	1-216-121-00	METAL GLAZE	1M 5% 1/10W
R153	1-216-069-00	METAL GLAZE	6.8K 5% 1/10W (KV-27V55 (U/C))	R336	1-216-295-00	METAL GLAZE	0 5% 1/10W
R154	1-216-041-00	METAL GLAZE	470 5% 1/10W (KV-27V55 (U/C))	R337	1-216-049-00	METAL GLAZE	1K 5% 1/10W
R155	1-216-049-00	METAL GLAZE	1K 5% 1/10W (KV-27V55 (U/C))	R338	1-249-417-11	CARBON	1K 5% 1/4W F
R156	1-216-073-00	METAL GLAZE	10K 5% 1/10W	R339	1-216-049-00	METAL GLAZE	1K 5% 1/10W
R157	1-216-073-00	METAL GLAZE	10K 5% 1/10W (KV-27V55 (U/C))	R340	1-216-077-00	METAL GLAZE	15K 5% 1/10W
R158	1-216-073-00	METAL GLAZE	10K 5% 1/10W (KV-27V55 (U/C))	R341	1-216-085-00	METAL GLAZE	33K 5% 1/10W
R159	1-216-049-00	METAL GLAZE	1K 5% 1/10W (KV-27V55 (U/C))	R342	1-216-295-00	METAL GLAZE	0 5% 1/10W
R160	1-216-049-00	METAL GLAZE	1K 5% 1/10W (KV-27V55 (U/C))	R343	1-216-053-00	METAL GLAZE	1.5K 5% 1/10W
R161	1-216-049-00	METAL GLAZE	1K 5% 1/10W (KV-27V55 (U/C))	R344	1-216-043-00	METAL GLAZE	560 5% 1/10W
R162	1-216-065-00	METAL GLAZE	4.7K 5% 1/10W (KV-27V55 (U/C))	R345	1-216-109-00	METAL GLAZE	330K 5% 1/10W
R163	1-216-065-00	METAL GLAZE	4.7K 5% 1/10W (KV-27V55 (U/C))	R346	1-216-071-00	METAL GLAZE	8.2K 5% 1/10W
R164	1-216-065-00	METAL GLAZE	4.7K 5% 1/10W (KV-27V55 (U/C))	R347	1-249-409-11	CARBON	220 5% 1/4W F
R165	1-216-065-00	METAL GLAZE	4.7K 5% 1/10W (KV-27V55 (U/C))	R348	1-216-097-00	METAL GLAZE	100K 5% 1/10W
R201	1-216-073-00	METAL GLAZE	10K 5% 1/10W	R349	1-216-089-00	METAL GLAZE	47K 5% 1/10W
R202	1-216-073-00	METAL GLAZE	10K 5% 1/10W	R350	1-216-089-00	METAL GLAZE	47K 5% 1/10W
R203	1-216-089-00	METAL GLAZE	47K 5% 1/10W	R351	1-216-065-00	METAL GLAZE	4.7K 5% 1/10W
R204	1-216-089-00	METAL GLAZE	47K 5% 1/10W	R352	1-216-089-00	METAL GLAZE	47K 5% 1/10W
R205	1-216-295-00	METAL GLAZE	0 5% 1/10W	R353	1-216-089-00	METAL GLAZE	47K 5% 1/10W
R206	1-216-295-00	METAL GLAZE	0 5% 1/10W	R354	1-216-033-00	METAL GLAZE	220 5% 1/10W
R207	1-216-085-00	METAL GLAZE	33K 5% 1/10W	R356	1-216-295-00	METAL GLAZE	0 5% 1/10W
R208	1-216-089-00	METAL GLAZE	47K 5% 1/10W	R374	1-216-033-00	METAL GLAZE	220 5% 1/10W
R209	1-216-085-00	METAL GLAZE	33K 5% 1/10W	R375	1-216-033-00	METAL GLAZE	220 5% 1/10W
R210	1-216-089-00	METAL GLAZE	47K 5% 1/10W	<CRYSTAL>			
R211	1-216-033-00	METAL GLAZE	220 5% 1/10W	X001	1-579-917-21	VIBRATOR, CRYSTAL	
R212	1-216-025-00	METAL GLAZE	100 5% 1/10W	X001	1-579-917-41	VIBRATOR, CRYSTAL	
R213	1-216-025-00	METAL GLAZE	100 5% 1/10W	X301	1-567-505-11	OSCILLATOR, CRYSTAL	
R218	1-216-073-00	METAL GLAZE	10K 5% 1/10W	*****			
R219	1-216-073-00	METAL GLAZE	10K 5% 1/10W	*A-1331-270-A C BOARD, COMPLETE			
R220	1-216-033-00	METAL GLAZE	220 5% 1/10W	*****			
				<CAPACITOR>			
				C700	1-102-074-00	CERAMIC	0.001MF 10% 50V
				C701	1-162-114-00	CERAMIC	0.0047MF 2KV
				C702	1-106-375-12	MYLAR	0.022MF 99% 200V
				C703	1-106-375-12	MYLAR	0.022MF 99% 200V
				C704	1-162-116-00	CERAMIC	680PF 10% 2KV
				C705	1-123-946-00	ELECT	4.7MF 20% 250V
				C706	1-126-101-11	ELECT	100MF 20% 16V
				C707	1-102-129-00	CERAMIC	0.01MF 10% 50V
				C711	1-164-083-11	CERAMIC	680PF 10% 50V



The components identified by shading and mark  $\Delta$  are critical for safety  
Replace only with part number specified

Les composants identifiés par une trame et une marque  $\Delta$  sont critiques pour la sécurité.  
Ne les remplacer que par une pièce portant le numéro spécifié.



REF. NO.	PART NO.	DESCRIPTION	REMARK	REF. NO.	PART NO.	DESCRIPTION	REMARK
*****							
	1-533-223-11	CLIP, FUSE		C612	1-136-169-00	FILM 0.22MF	5% 50V
	1-923-221-02	WIRE UL1007 AWG22 170MM BLK		C613	1-164-625-11	CERAMIC 680PF	10% 500V
	4-382-854-11	SCREW (M3X10), P, SW (+)		C614	1-164-625-11	CERAMIC 680PF	10% 500V
<CAPACITOR>							
C501	1-124-557-11	ELECT 1000MF	20% 25V	C616	1-124-907-11	ELECT 10MF	20% 50V
C502	1-162-131-11	CERAMIC 220PF	10% 2KV	C617	1-124-607-11	ELECT 2200MF	20% 50V
C503	1-124-557-11	ELECT 1000MF	20% 25V	C618	1-124-557-11	ELECT 1000MF	20% 25V
C504	1-137-366-11	FILM 0.0022MF	5% 50V	C619	1-124-360-00	ELECT 1000MF	20% 16V
C505	1-124-916-11	ELECT 22MF	20% 25V	C620	1-164-644-11	CERAMIC 330PF	10% 500V
C506	1-124-929-11	ELECT 22MF	20% 100V	C621	1-126-356-11	ELECT 220MF	20% 160V
C507	1-124-046-00	ELECT 10MF	20% 160V	C623	1-162-117-00	CERAMIC 100PF	10% 500V
C508	1-129-898-00	FILM 0.0022MF	5% 630V	C624	1-136-487-81	FILM 0.015MF	5% 50V
C509	1-124-916-11	ELECT 22MF	20% 25V	C625	1-129-744-91	FILM 0.027MF	10% 400V
C511	1-123-024-21	ELECT 33MF	160V	C626	1-124-478-11	ELECT 100MF	20% 25V
C512	1-102-212-00	CERAMIC 820PF	10% 500V	C627	1-124-443-00	ELECT 100MF	20% 10V
C513	1-102-212-00	CERAMIC 820PF	10% 500V	<del>C628</del>	<del>1-164-487-81</del>	<del>CERAMIC 470PF</del>	<del>20% 400V</del>
C514	1-102-244-00	CERAMIC 220PF	10% 500V	C634	1-165-127-11	CERAMIC 470PF	10% 500V
C515	1-137-416-11	FILM 0.01MF	10% 100V	C635	1-124-477-11	ELECT 47MF	20% 16V
C517	1-162-116-00	CERAMIC 680PF	10% 2KV	C636	1-137-374-11	FILM 0.047MF	5% 50V
C518	1-162-116-00	CERAMIC 680PF	10% 2KV	C637	1-124-916-11	ELECT 22MF	20% 25V
<del>C519</del>	<del>1-104-771-11</del>	<del>FILM 0.02MF</del>	<del>3% 2KV</del>	C640	1-124-902-00	ELECT 0.47MF	20% 50V
<del>C520</del>	<del>1-182-134-91</del>	<del>CERAMIC 470PF</del>	<del>10% 2KV</del>	C641	1-124-443-00	ELECT 100MF	20% 10V
<del>C521</del>	<del>1-136-316-51</del>	<del>FILM 0.056MF</del>	<del>5% 630V</del>	C642	1-137-217-11	FILM 0.01MF	5% 1.25KV
C522	1-106-383-00	MYLAR 0.047MF	99% 200V	C643	1-137-218-11	FILM 0.012MF	5% 1.25KV
C523	1-102-002-00	CERAMIC 680PF	10% 500V	C645	1-102-125-00	CERAMIC 0.0047MF	10% 50V
C524	1-102-212-00	CERAMIC 820PF	10% 500V	C646	1-126-101-11	ELECT 100MF	20% 16V
C525	1-124-902-00	ELECT 0.47MF	20% 50V	C647	1-124-916-11	ELECT 22MF	20% 25V
C526	1-106-395-00	MYLAR 0.15MF	10% 200V	C684	1-124-907-11	ELECT 10MF	20% 50V
C527	1-124-341-00	ELECT 1MF	20% 200V	C695	1-124-907-11	ELECT 10MF	20% 50V
C528	1-136-113-00	FILM 2MF	5% 200V	C2205	1-124-925-11	ELECT 2.2MF	20% 50V
C529	1-137-410-11	FILM 0.001MF	10% 100V	C2208	1-124-925-11	ELECT 2.2MF	20% 50V
C530	1-104-770-11	FILM 0.62MF	5% 200V	C2210	1-124-120-11	ELECT 220MF	20% 25V
C531	1-124-477-11	ELECT 47MF	20% 25V	C2211	1-124-477-11	ELECT 47MF	20% 25V
C532	1-136-165-00	FILM 0.1MF	5% 50V	C2212	1-124-120-11	ELECT 220MF	20% 25V
C533	1-124-927-11	ELECT 4.7MF	20% 50V	C2213	1-136-173-00	FILM 0.47MF	5% 50V
C534	1-136-161-00	FILM 0.047MF	5% 50V	C2215	1-136-169-00	FILM 0.22MF	5% 50V
C535	1-124-911-11	ELECT 220MF	20% 50V	C2216	1-126-105-11	ELECT 1000MF	20% 35V
C536	1-137-421-91	FILM 0.068MF	10% 100V	C2217	1-136-169-00	FILM 0.22MF	5% 50V
C538	1-136-161-00	FILM 0.047MF	5% 50V	C2218	1-126-105-11	ELECT 1000MF	20% 35V
C540	1-137-366-11	FILM 0.0022MF	5% 50V	C2219	1-126-105-11	ELECT 1000MF	20% 35V
C541	1-137-366-11	FILM 0.0022MF	5% 50V	C2220	1-124-925-11	ELECT 2.2MF	20% 50V
C542	1-130-481-00	FILM 0.0068MF	5% 50V	<CONNECTOR>			
C545	1-124-927-11	ELECT 4.7MF	20% 50V	CN104	*1-573-979-11	CONNECTOR, BOARD TO BOARD 11P	
C547	1-164-079-11	CERAMIC 330PF	10% 50V	CN105	*1-508-768-00	PIN, CONNECTOR (5MM PITCH) 6P	
<del>C548</del>	<del>1-162-116-91</del>	<del>CERAMIC 680PF</del>	<del>10% 2KV</del>	CN107	*1-580-798-11	CONNECTOR PIN (DY) 6P	
C550	1-106-387-00	MYLAR 0.068MF	10% 200V	CN113	*1-508-765-00	PIN, CONNECTOR (5MM PITCH) 3P	
C553	1-164-079-11	CERAMIC 330PF	10% 50V	CN114	*1-580-843-11	PIN, CONNECTOR (POWER)	
C561	1-162-815-11	CERAMIC 47PF	5% 500V	CN115	1-573-298-11	CONNECTOR, BOARD TO BOARD 20P	
C595	1-123-932-00	ELECT 4.7MF	20% 160V	CN116	*1-691-616-11	CONNECTOR, BOARD TO BOARD 15P	
C598	1-124-342-00	ELECT 3.3MF	20% 160V	CN117	*1-573-978-11	CONNECTOR, BOARD TO BOARD 11P	
C600	1-124-907-11	ELECT 10MF	20% 50V	<DIODE>			
<del>C601</del>	<del>1-136-311-51</del>	<del>FILM 0.47MF</del>	<del>20% 125V</del>	D501	8-719-028-72	DIODE RGP02-17BL-6433	
<del>C602</del>	<del>1-136-311-51</del>	<del>FILM 0.47MF</del>	<del>20% 125V</del>	D502	8-719-979-85	DIODE BGP20G	
<del>C603</del>	<del>1-136-311-51</del>	<del>FILM 0.47MF</del>	<del>20% 125V</del>	D503	8-719-979-85	DIODE BGP20G	
<del>C604</del>	<del>1-162-578-81</del>	<del>CERAMIC 0.0047MF</del>	<del>20% 400V</del>	<del>D504</del>	<del>8-719-302-44</del>	<del>DIODE EL12-V1</del>	
C607	1-104-757-11	ELECT 470MF	20% 200V	D505	8-719-936-84	DIODE RGP10GPKG3	
C608	1-104-757-11	ELECT 470MF	20% 200V	D506	8-719-945-80	DIODE ERC06-15S	
C609	1-136-169-00	FILM 0.22MF	5% 50V	D507	8-719-945-80	DIODE ERC06-15S	
C610	1-136-169-00	FILM 0.22MF	5% 50V	D508	8-719-900-26	DIODE ERD29-08J	
C611	1-136-169-00	FILM 0.22MF	5% 50V	D509	8-719-936-84	DIODE RGP10GPKG3	
				D510	8-719-936-82	DIODE GPO8DPKG3	

**D**

• The components identified by **⊠** in this manual have been carefully factory-selected for each set in order to satisfy regulations regarding X-ray radiation. Should replacement be required, replace only with the value originally used.

Les composants identifiés par une trame et une marque **⊠** sont critiques pour la sécurité. Ne les remplacer que par une pièce portant le numéro spécifié.

The components identified by shading and mark **⊠** are critical for safety. Replace only with part number specified.

REF. NO.	PART NO.	DESCRIPTION	REMARK	REF. NO.	PART NO.	DESCRIPTION	REMARK
D511	8-719-936-82	DIODE GP08DPKG3		IC606	8-759-982-10	IC RC7809FA	
D512	8-719-109-84	DIODE RD5.1ESB1		IC610	8-759-982-21	IC RC78L05A	
D513	8-719-936-82	DIODE GP08DPKG3		IC2200	8-759-089-13	IC TDA7262	
D514	8-719-911-19	DIODE ISS119		<JUMPER RESISTOR>			
D515	8-719-911-19	DIODE ISS119		JW651	1-216-341-11	METAL OXIDE 0.22 5% 1W F	
D601	8-719-911-19	DIODE ISS119		<COIL>			
<del>D602</del>	<del>8-719-510-63</del>	<del>DIODE D2S4MF</del>		L502	1-421-465-00	COIL, FERRITE CHOKE 68UH	
D603	8-719-500-69	DIODE S3V1OSS		L503	1-412-524-11	INDUCTOR 8.2UH	
D605	8-719-500-69	DIODE S3V1OSS		L504	1-410-669-31	INDUCTOR 33UH	
D607	8-719-510-02	DIODE D1NS4		L505	1-459-104-00	COIL, WITH CORE	
D608	8-719-022-97	DIODE D2S4MF		L506	1-422-613-11	COIL, AIR CORE	
D609	8-719-022-97	DIODE D2S4MF		L508	1-412-553-11	INDUCTOR 3.3MMH	
D610	8-719-022-97	DIODE D2S4MF		<del>L509</del>	<del>1-468-173-23</del>	<del>COIL, HORIZONTAL LINEARITY</del>	
D611	8-719-022-97	DIODE D2S4MF		L510	1-406-607-11	COIL, CHOKE 15MMH	
D612	8-719-031-80	DIODE D5SC4MR		L513	1-412-524-11	INDUCTOR 8.2UH	
D613	8-719-022-97	DIODE D2S4MF		<PROTECTOR MODULE>			
D614	8-719-110-33	DIODE RD12ESB3		PM501	1-810-061-11	PROTECTOR MODULE PM-38	
D615	8-719-027-43	DIODE S2L2OUF		<IC LINK>			
D616	8-719-027-43	DIODE S2L2OUF		<del>PS220181</del>	<del>1-532-984-31</del>	<del>LINK, IC</del>	
D617	8-719-027-43	DIODE S2L2OUF		<TRANSISTOR>			
D618	8-719-027-43	DIODE S2L2OUF		Q502	8-729-119-80	TRANSISTOR 2SC2688-LK	
D619	8-719-510-02	DIODE D1NS4		Q503	8-729-809-29	TRANSISTOR 2SC4159-E	
D622	8-719-911-19	DIODE ISS119		Q505	8-729-119-78	TRANSISTOR 2SC2785-HFE	
D623	8-719-911-19	DIODE ISS119		Q591	8-729-016-32	TRANSISTOR 2SC4927-01	
D624	8-719-911-19	DIODE ISS119		Q601	8-729-019-51	TRANSISTOR 2SC4834MNP	
D626	8-719-510-48	DIODE D1N20R		Q602	8-729-019-51	TRANSISTOR 2SC4834MNP	
D627	8-719-510-48	DIODE D1N20R		Q603	8-729-119-76	TRANSISTOR 2SA1175-HFE	
D628	8-719-911-19	DIODE ISS119		Q604	8-729-119-78	TRANSISTOR 2SC2785-HFE	
D629	8-719-936-82	DIODE GP08DPKG3		Q605	8-729-119-78	TRANSISTOR 2SC2785-HFE	
D630	8-719-936-82	DIODE GP08DPKG3		Q611	8-729-119-78	TRANSISTOR 2SC2785-HFE	
D631	8-719-936-82	DIODE GP08DPKG3		Q613	8-729-924-90	TRANSISTOR 2SB1370-EF	
D632	8-719-936-82	DIODE GP08DPKG3		Q614	8-729-119-78	TRANSISTOR 2SC2785-HFE	
D633	8-719-110-09	DIODE RD8.2ESB3		Q2202	8-729-119-78	TRANSISTOR 2SC2785-HFE	
D634	8-719-911-19	DIODE ISS119		Q2203	8-729-119-76	TRANSISTOR 2SA1175-HFE	
D635	8-719-911-19	DIODE ISS119		<RESISTOR>			
D636	8-719-510-48	DIODE D1N20R		R501	1-249-378-11	CARBON 0.56 5% 1/4W F	
D637	8-719-911-19	DIODE ISS119		R503	1-215-862-11	METAL OXIDE 68 5% 1W F	
D638	8-719-911-19	DIODE ISS119		R504	1-215-872-11	METAL OXIDE 3.3K 5% 1W F	
<FUSE>				R505	1-249-377-11	CARBON 0.47 5% 1/4W F	
<del>FB601</del>	<del>1-532-748-11</del>	<del>FUSE, GLASS TUBE (6.3A/125V)</del>		R506	1-215-886-11	METAL OXIDE 100 5% 2W F	
<FERRITE BEAD>				R507	1-249-429-11	CARBON 10K 5% 1/4W	
FB501	1-412-911-11	INDUCTOR, FERRITE BEAD		R508	1-249-425-11	CARBON 4.7K 5% 1/4W	
FB502	1-412-911-11	INDUCTOR, FERRITE BEAD		R509	1-249-389-11	CARBON 4.7 5% 1/4W F	
FB601	1-412-911-11	INDUCTOR, FERRITE BEAD		<del>R511</del>	<del>1-249-389-11</del>	<del>CARBON 4.7 5% 1/4W F</del>	
FB602	1-412-911-11	INDUCTOR, FERRITE BEAD		R512	1-249-389-11	CARBON 4.7 5% 1/4W F	
FB603	1-412-911-11	INDUCTOR, FERRITE BEAD		R513	1-216-393-00	METAL OXIDE 2.2 5% 3W F	
FB604	1-412-911-11	INDUCTOR, FERRITE BEAD		R514	1-249-429-11	CARBON 10K 5% 1/4W	
FB605	1-412-911-11	INDUCTOR, FERRITE BEAD		R515	1-216-363-00	METAL OXIDE 0.33 5% 2W F	
FB606	1-412-911-11	INDUCTOR, FERRITE BEAD		R516	1-249-401-11	CARBON 47 5% 1/4W	
FB613	1-412-911-11	INDUCTOR, FERRITE BEAD		R517	1-215-916-00	METAL OXIDE 680 5% 3W F	
FB614	1-412-911-11	INDUCTOR, FERRITE BEAD		R518	1-215-916-00	METAL OXIDE 680 5% 3W F	
<IC>				R519	1-249-426-11	CARBON 5.6K 5% 1/4W F	
IC501	8-759-980-58	IC TDA8172					
IC504	8-759-103-93	IC UPC393C					
<del>IC601A</del>	<del>1-810-051-11</del>	<del>POWER MODULE DR-48</del>					
IC602	8-759-805-37	IC L78LR05D-MA					
IC604	8-759-924-12	IC LM7805CT					
IC605	8-759-929-62	IC LM7812CT					

The components identified by shading and mark  $\Delta$  are critical for safety  
Replace only with part number specified

Les composants identifiés par une trame et une marque  $\Delta$  sont critiques pour la sécurité.  
Ne les remplacer que par une pièce portant le numéro spécifique.

The components identified by  $\boxtimes$  in this manual have been carefully factory-selected for each set in order to satisfy regulations regarding X-ray radiation  
Should replacement be required, replace only with the value originally used

D

REF. NO.	PART NO.	DESCRIPTION	REMARK	REF. NO.	PART NO.	DESCRIPTION	REMARK
R520	1-249-423-11	CARBON	3.3K 5% 1/4W	<del>R640 <math>\Delta</math></del>	<del>1-202-893-91</del>	<del>SOLID</del>	<del>8.2K 20% 1/2W</del>
R521	1-249-411-11	CARBON	330 5% 1/4W	R643	1-216-379-11	METAL OXIDE	6.8 5% 2W F
R522	1-215-886-11	METAL OXIDE	100 5% 2W F	<del>R644 <math>\Delta</math></del>	<del>1-212-853-63</del>	<del>FUSIBLE</del>	<del>6.8 5% 1/2W F</del>
R523	1-215-862-11	METAL OXIDE	68 5% 1W F	R645	1-249-377-11	CARBON	0.47 5% 1/4W F
<del>R524 <math>\Delta</math></del>	<del>1-249-423-11</del>	<del>CARBON</del>	<del>3.3K 5% 1/4W</del>	R646	1-249-429-11	CARBON	10K 5% 1/4W
R525	1-215-884-11	METAL OXIDE	47 5% 2W F	R647	1-249-433-11	CARBON	22K 5% 1/4W
R526	1-247-887-00	CARBON	220K 5% 1/4W	R648	1-249-414-11	CARBON	560 5% 1/4W
R527	1-215-861-00	METAL OXIDE	47 5% 1W F	R649	1-216-431-11	METAL OXIDE	560 5% 1W F
R528	1-260-326-71	CARBON	680 5% 1/2W	R650	1-249-405-11	CARBON	100 5% 1/4W F
R530	1-215-445-00	METAL	10K 1% 1/4W	<del>R651 <math>\Delta</math></del>	<del>1-212-954-63</del>	<del>FUSIBLE</del>	<del>6.8 5% 1/2W F</del>
R531	1-247-903-00	CARBON	1M 5% 1/4W	<del>R652 <math>\Delta</math></del>	<del>1-212-954-63</del>	<del>FUSIBLE</del>	<del>6.8 5% 1/2W F</del>
R532	1-215-446-00	METAL	11K 1% 1/4W	R653	1-249-381-11	CARBON	1 5% 1/4W
R534	1-249-385-11	CARBON	2.2 5% 1/4W F	R654	1-216-385-11	METAL OXIDE	0.47 5% 3W F
R535	1-216-453-00	METAL OXIDE	270 5% 2W F	R655	1-249-417-11	CARBON	1K 5% 1/4W F
R536	1-249-389-11	CARBON	4.7 5% 1/4W F	R656	1-249-381-11	CARBON	1 5% 1/4W
R539	1-215-459-00	METAL	39K 1% 1/4W	R657	1-249-417-11	CARBON	1K 5% 1/4W
R543	1-249-419-11	CARBON	1.5K 5% 1/4W	R658	1-249-389-11	CARBON	4.7 5% 1/4W F
R546	1-249-431-11	CARBON	15K 5% 1/4W	R659	1-247-883-00	CARBON	150K 5% 1/4W
R547	1-247-883-00	CARBON	150K 5% 1/4W	R660	1-249-433-11	CARBON	22K 5% 1/4W
R550	1-249-429-11	CARBON	10K 5% 1/4W	R661	1-249-406-11	CARBON	120 5% 1/4W
R551	1-249-429-11	CARBON	10K 5% 1/4W	R690	1-249-423-11	CARBON	3.3K 5% 1/4W
R554	1-216-371-00	METAL OXIDE	1.5 5% 2W F	R2209	1-249-427-11	CARBON	6.8K 5% 1/4W
R556	1-249-411-11	CARBON	330 5% 1/4W	R2210	1-249-431-11	CARBON	15K 5% 1/4W
R557	1-249-415-11	CARBON	680 5% 1/4W F	R2211	1-249-427-11	CARBON	6.8K 5% 1/4W
R561	1-249-429-11	CARBON	10K 5% 1/4W	R2212	1-249-431-11	CARBON	15K 5% 1/4W
R562	1-215-437-00	METAL	4.7K 1% 1/4W	R2215	1-249-425-11	CARBON	4.7K 5% 1/4W
R563	1-249-429-11	CARBON	10K 5% 1/4W	R2216	1-249-437-11	CARBON	47K 5% 1/4W
R564	1-249-433-11	CARBON	22K 5% 1/4W	R2217	1-249-435-11	CARBON	33K 5% 1/4W
R566	1-249-435-11	CARBON	33K 5% 1/4W	R2218	1-249-441-11	CARBON	100K 5% 1/4W
R580	1-249-411-11	CARBON	330 5% 1/4W	R2219	1-249-413-11	CARBON	470 5% 1/4W
<del>R601 <math>\Delta</math></del>	<del>1-202-888-91</del>	<del>SOLID</del>	<del>2.2K 20% 1/2W</del>	R2220	1-249-430-11	CARBON	12K 5% 1/4W
<del>R602 <math>\Delta</math></del>	<del>1-202-888-91</del>	<del>SOLID</del>	<del>3.3K 20% 1/2W</del>	R2221	1-249-430-11	CARBON	12K 5% 1/4W
R603	1-249-419-11	CARBON	1.5K 5% 1/4W	R2222	1-249-398-11	CARBON	27 5% 1/4W
R605	1-247-893-11	CARBON	390K 5% 1/4W	R2223	1-249-418-11	CARBON	1.2K 5% 1/4W F
R606	1-247-893-11	CARBON	390K 5% 1/4W	R2224	1-249-418-11	CARBON	1.2K 5% 1/4W F
<del>R607 <math>\Delta</math></del>	<del>1-202-933-61</del>	<del>FUSIBLE</del>	<del>0.1 10% 1/2W F</del>	R2225	1-249-398-11	CARBON	27 5% 1/4W
R608	1-215-860-11	METAL OXIDE	33 5% 1W F	R2226	1-249-385-11	CARBON	2.2 5% 1/4W F
R609	1-216-352-11	METAL OXIDE	1.8 5% 1W F	R2227	1-249-385-11	CARBON	2.2 5% 1/4W F
R610	1-216-352-11	METAL OXIDE	1.8 5% 1W F	R2228	1-249-421-11	CARBON	2.2K 5% 1/4W
R611	1-216-468-91	METAL OXIDE	82K 5% 2W F	R2229	1-249-421-11	CARBON	2.2K 5% 1/4W
R612	1-216-468-91	METAL OXIDE	82K 5% 2W F	<RELAY>			
R613	1-215-860-11	METAL OXIDE	33 5% 1W F	<del>RY601 <math>\Delta</math></del>	<del>1-515-684-22</del>	<del>RELAY</del>	
R614	1-215-860-11	METAL OXIDE	33 5% 1W F	RY602	1-515-516-00	RELAY	
R615	1-249-421-11	CARBON	2.2K 5% 1/4W	<SWITCH>			
R616	1-249-417-11	CARBON	1K 5% 1/4W	S501	1-572-707-11	SWITCH, LEVER	
R617	1-249-377-11	CARBON	0.47 5% 1/4W F	S502	1-572-707-11	SWITCH, LEVER	
R618	1-249-377-11	CARBON	0.47 5% 1/4W F	<TRANSFORMER>			
R619	1-249-377-11	CARBON	0.47 5% 1/4W F	T501 $\Delta$	1-453-146-11	TRANSFORMER ASSY, FLYBACK (NX-2604A3)	
R621	1-249-377-11	CARBON	0.47 5% 1/4W F	T502 $\Delta$	1-437-195-14	TRANSFORMER, HORIZONTAL DRIVE	
R622	1-249-377-11	CARBON	0.47 5% 1/4W F	T503 $\Delta$	1-424-545-22	TRANSFORMER, FERRITE (PMT)	
R623	1-249-377-11	CARBON	0.47 5% 1/4W F	T601 $\Delta$	1-423-593-11	TRANSFORMER, LINE FILTER (LFT)	
R624	1-249-377-11	CARBON	0.47 5% 1/4W F	<del>T602 <math>\Delta</math></del>	<del>1-424-220-23</del>	<del>TRANSFORMER, LINE FILTER</del>	
R625	1-249-377-11	CARBON	0.47 5% 1/4W F	T603 $\Delta$	1-423-563-11	TRANSFORMER, CONVERTER DRIVE	
R627	1-249-377-11	CARBON	0.47 5% 1/4W F	<del>T604 <math>\Delta</math></del>	<del>1-423-615-11</del>	<del>TRANSFORMER, CONVERTER (PMT)</del>	
R628	1-249-377-11	CARBON	0.47 5% 1/4W F	T605	1-423-582-11	TRANSFORMER, FERRITE (SBT)	
R629	1-249-388-11	CARBON	3.9 5% 1/4W F				
R630	1-215-857-11	METAL OXIDE	10 5% 1W F				
R632	1-249-417-11	CARBON	1K 5% 1/4W F				
R633	1-249-405-11	CARBON	100 5% 1/4W F				
R635	1-249-413-11	CARBON	470 5% 1/4W F				
R636	1-249-383-11	CARBON	1.5 5% 1/4W F				
R637	1-249-421-11	CARBON	2.2K 5% 1/4W				
R638	1-249-423-11	CARBON	3.3K 5% 1/4W				
R639	1-249-423-11	CARBON	3.3K 5% 1/4W				

**D** **H** **UA**

Les composants identifiés par  
une trame et une marque  $\Delta$   
sont critiques pour la sécurité  
Ne les remplacer que par une  
pièce portant le numéro spécifique.

The components identified by  
shading and mark  $\Delta$  are critical  
for safety  
Replace only with part number  
specified.

REF. NO.	PART NO.	DESCRIPTION	REMARK	REF. NO.	PART NO.	DESCRIPTION	REMARK
<THERMISTOR>							
<del>THP601A1</del>	<del>809-539-11</del>	<del>THERMISTOR, POSITIVE</del>		*****			
<VARISTOR>							
VDR601	1-807-288-11	VARISTOR		*A-1394-418-A UA BOARD, COMPLETE			
VDR602	1-810-053-21	VARISTOR		*****			
VDR603	1-810-053-21	VARISTOR		<CAPACITOR>			
*****				C401	1-163-031-11	CERAMIC CHIP 0.01MF	50V
*1-646-717-11	H BOARD	*****		C402	1-124-916-11	ELECT 22MF	20% 25V
<CAPACITOR>				C405	1-124-916-11	ELECT 22MF	20% 25V
C1001	1-124-916-11	ELECT 22MF	20% 25V	C406	1-124-903-11	ELECT 1MF	20% 50V
C1002	1-124-903-11	ELECT 1MF	20% 50V	C407	1-124-903-11	ELECT 1MF	20% 50V
C1003	1-124-903-11	ELECT 1MF	20% 50V	C408	1-124-916-11	ELECT 22MF	20% 25V
C1004	1-124-122-11	ELECT 100MF	20% 50V	C409	1-124-903-11	ELECT 1MF	20% 50V
<CONNECTOR>				C410	1-124-903-11	ELECT 1MF	20% 50V
CN154	*1-564-520-11	PLUG, CONNECTOR 5P		C412	1-124-916-11	ELECT 22MF	20% 25V
CN155	*1-564-523-11	PLUG, CONNECTOR 8P		C413	1-124-907-11	ELECT 10MF	20% 50V
<DIODE>				C414	1-124-499-11	ELECT 1MF	20% 50V
D1004	1-810-039-11	LED UNIT		C415	1-124-499-11	ELECT 1MF	20% 50V
<IC>				C416	1-124-907-11	ELECT 10MF	20% 50V
IC1001	8-746-185-11	IC SBX1618-59		C417	1-124-902-00	ELECT 0.47MF	20% 50V
<JACK>				C418	1-124-902-00	ELECT 0.47MF	20% 50V
J1001	1-695-585-11	JACK BLOCK, PIN (L TYPE) 3P		C419	1-124-477-11	ELECT 47MF	20% 16V
<RESISTOR>				C420	1-163-031-11	CERAMIC CHIP 0.01MF	50V
R1001	1-247-804-11	CARBON 75 5%	1/4W	C421	1-124-916-11	ELECT 22MF	20% 25V
R1002	1-249-425-11	CARBON 4.7K 5%	1/4W	C433	1-124-482-11	ELECT 33MF	20% 25V
R1003	1-216-113-00	METAL GLAZE 470K 5%	1/10W	C434	1-163-117-00	CERAMIC CHIP 100PF	5% 50V
R1004	1-249-425-11	CARBON 4.7K 5%	1/4W	C440	1-124-907-11	ELECT 10MF	20% 50V
R1005	1-216-113-00	METAL GLAZE 470K 5%	1/10W	C441	1-124-477-11	ELECT 47MF	20% 16V
R1007	1-216-073-00	METAL GLAZE 10K 5%	1/10W	C442	1-163-117-00	CERAMIC CHIP 100PF	5% 50V
R1008	1-216-025-00	METAL GLAZE 100 5%	1/10W	C462	1-126-101-11	ELECT 100MF	20% 16V
R1009	1-216-065-00	METAL GLAZE 4.7K 5%	1/10W	<FILTER BLOCK>			
R1010	1-216-055-00	METAL GLAZE 1.8K 5%	1/10W	CM402	1-466-912-21	FILTER BLOCK, COMB	
R1011	1-216-025-00	METAL GLAZE 100 5%	1/10W	<CONNECTOR>			
R1012	1-216-049-00	METAL GLAZE 1K 5%	1/10W	CN141	*1-564-520-11	PLUG, CONNECTOR 5P	
R1013	1-216-033-00	METAL GLAZE 220 5%	1/10W	CN143	1-750-395-11	SOCKET, CONNECTOR 32P	
R1014	1-216-047-00	METAL GLAZE 820 5%	1/10W	CN146	1-573-300-11	CONNECTOR, BOARD TO BOARD 18P	
R1015	1-216-033-00	METAL GLAZE 220 5%	1/10W	CN147	1-750-395-11	SOCKET, CONNECTOR 32P	
<SWITCH>				CN148	*1-564-517-11	PLUG, CONNECTOR 2P	
S1001	1-571-532-21	SWITCH, TACTIL		<DIODE>			
S1002	1-571-532-21	SWITCH, TACTIL		D401	8-719-110-17	DIODE RD10ESB2	
S1003	1-571-532-21	SWITCH, TACTIL		D402	8-719-110-17	DIODE RD10ESB2	
S1004	1-571-532-21	SWITCH, TACTIL		D403	8-719-110-17	DIODE RD10ESB2	
S1005	1-571-532-21	SWITCH, TACTIL		D404	8-719-110-17	DIODE RD10ESB2	
S1006	1-571-532-21	SWITCH, TACTIL		D405	8-719-110-17	DIODE RD10ESB2	
<del>S1007</del>	<del>1-571-532-21</del>	<del>SWITCH, TACTIL</del>		D408	8-719-110-17	DIODE RD10ESB2	
				D410	8-719-110-17	DIODE RD10ESB2	
				D411	8-719-110-17	DIODE RD10ESB2	
				D429	8-719-110-17	DIODE RD10ESB2	
				D430	8-719-110-17	DIODE RD10ESB2	
				D431	8-719-110-17	DIODE RD10ESB2	
				D436	8-719-110-17	DIODE RD10ESB2	
				D437	8-719-110-17	DIODE RD10ESB2	
				<IC>			
				IC402	8-752-062-86	IC CXA1545AS	

The components identified by shading and mark  $\Delta$  are critical for safety. Replace only with part number specified.

Les composants identifiés par une trame et une marque  $\Delta$  sont critiques pour la sécurité. Ne les remplacer que par une pièce portant le numéro spécifié.

UA

REF. NO.	PART NO.	DESCRIPTION	REMARK	REF. NO.	PART NO.	DESCRIPTION	REMARK
<JACK>							
J401	1-750-515-11	TERMINAL BLOCK, S 3P		R435	1-216-295-00	METAL GLAZE	0 5% 1/10W
J402	1-750-517-11	JACK BLOCK, PIN 3P		R439	1-216-049-00	METAL GLAZE	1K 5% 1/10W
J403	1-750-545-11	JACK BLOCK, PIN 3P		R441	1-216-049-00	METAL GLAZE	1K 5% 1/10W
J404	1-750-516-11	JACK BLOCK, PIN 2P		R444	1-216-095-00	METAL GLAZE	82K 5% 1/10W
<JUMPER RESISTOR>							
JR402	1-216-295-00	METAL GLAZE	0 5% 1/10W	R445	1-216-073-00	METAL GLAZE	10K 5% 1/10W
JR403	1-216-295-00	METAL GLAZE	0 5% 1/10W	R446	1-216-073-00	METAL GLAZE	10K 5% 1/10W
JR408	1-216-295-00	METAL GLAZE	0 5% 1/10W	R450	1-216-643-11	METAL CHIP	470 0.50% 1/10W
JR410	1-216-295-00	METAL GLAZE	0 5% 1/10W	R451	1-216-065-00	METAL GLAZE	4.7K 5% 1/10W
JR411	1-216-295-00	METAL GLAZE	0 5% 1/10W	R453	1-216-645-11	METAL CHIP	560 0.50% 1/10W
JR412	1-216-295-00	METAL GLAZE	0 5% 1/10W	R454	1-216-295-00	METAL GLAZE	0 5% 1/10W
JR415	1-216-295-00	METAL GLAZE	0 5% 1/10W	R456	1-216-041-00	METAL GLAZE	470 5% 1/10W
JR416	1-216-295-00	METAL GLAZE	0 5% 1/10W	R457	1-216-033-00	METAL GLAZE	220 5% 1/10W
JR418	1-216-295-00	METAL GLAZE	0 5% 1/10W	R458	1-216-033-00	METAL GLAZE	220 5% 1/10W
JR419	1-216-295-00	METAL GLAZE	0 5% 1/10W	R475	1-216-049-00	METAL GLAZE	1K 5% 1/10W
JR429	1-216-295-00	METAL GLAZE	0 5% 1/10W	R478	1-216-041-00	METAL GLAZE	470 5% 1/10W
JR430	1-216-295-00	METAL GLAZE	0 5% 1/10W	R482	1-249-417-11	CARBON	1K 5% 1/4W
JR431	1-216-295-00	METAL GLAZE	0 5% 1/10W	R483	1-249-417-11	CARBON	1K 5% 1/4W
JR434	1-216-295-00	METAL GLAZE	0 5% 1/10W	R438	1-216-081-00	METAL GLAZE	22K 5% 1/10W
JR435	1-216-295-00	METAL GLAZE	0 5% 1/10W	*****			
JR498	1-216-295-00	METAL GLAZE	0 5% 1/10W	MISCELLANEOUS			
JR499	1-216-295-00	METAL GLAZE	0 5% 1/10W	*****			
<COIL>							
L401	1-410-473-11	INDUCTOR	18UH	1-406-726-11 COIL, DEGAUSSING			
L403	1-410-476-11	INDUCTOR	33UH	1-451-275-41 DEFLECTION YOKE (2SPR)			
L404	1-410-669-31	INDUCTOR	33UH	1-452-032-00 MAGNET, DISK			
				1-452-094-00 MAGNET, ROTABLE DISK:15MM			
				1-504-322-11 BOX, SPEAKER (10CM.5CM)			
				1-573-657-11 PLUG, F-PIN			
				1-751-059-11 CORE, POWER (WITH CONNECTOR) (10K/125K)			
				1-941-989-02 CABLE, DGC P133D			
				9001-1-723-336-05 PICTURE TUBE (A58K2150K)			
				*****			
<TRANSISTOR>				ACCESSORIES & PACKING MATERIALS			
Q401	8-729-422-27	TRANSISTOR	2SD601A-Q	*****			
Q405	8-729-422-36	TRANSISTOR	2SB709A-Q	3-756-904-21	MANUAL, INSTRUCTION		
Q406	8-729-422-36	TRANSISTOR	2SB709A-Q	3-756-904-41	MANUAL, INSTRUCTION		
Q414	8-729-422-27	TRANSISTOR	2SD601A-Q	*4-039-970-01	INDIVIDUAL CARTON		
				*4-039-971-01	CUSHION (UPPER) (ASSY)		
				*4-039-972-01	CUSHION (LOWER) (ASSY)		
				*4-396-065-01	BAG, PROTECTION		
				1-467-072-11	REMOTE COMMANDER (RM-Y119)		
				9-904-195-01	COVER, BATTERY (RM-Y119)		
<RESISTOR>							
R401	1-247-804-11	CARBON	75 5% 1/4W				
R402	1-216-113-00	METAL GLAZE	470K 5% 1/10W				
R403	1-216-113-00	METAL GLAZE	470K 5% 1/10W				
R404	1-247-804-11	CARBON	75 5% 1/4W				
R405	1-216-113-00	METAL GLAZE	470K 5% 1/10W				
R406	1-216-113-00	METAL GLAZE	470K 5% 1/10W				
R407	1-247-804-11	CARBON	75 5% 1/4W				
R408	1-216-113-00	METAL GLAZE	470K 5% 1/10W				
R409	1-216-113-00	METAL GLAZE	470K 5% 1/10W				
R410	1-249-425-11	CARBON	4.7K 5% 1/4W				
R411	1-249-425-11	CARBON	4.7K 5% 1/4W				
R412	1-249-425-11	CARBON	4.7K 5% 1/4W				
R413	1-249-425-11	CARBON	4.7K 5% 1/4W				
R414	1-247-804-11	CARBON	75 5% 1/4W				
R415	1-216-065-00	METAL GLAZE	4.7K 5% 1/10W				
R416	1-216-647-11	METAL CHIP	680 0.50% 1/10W				
R417	1-216-645-11	METAL CHIP	560 0.50% 1/10W				
R421	1-216-065-00	METAL GLAZE	4.7K 5% 1/10W				
R425	1-216-065-00	METAL GLAZE	4.7K 5% 1/10W				
R431	1-216-049-00	METAL GLAZE	1K 5% 1/10W				
R432	1-216-295-00	METAL GLAZE	0 5% 1/10W				
R434	1-216-049-00	METAL GLAZE	1K 5% 1/10W				

