

TOSHIBA

FILE NO. 050-200309

SERVICE MANUAL

COLOR TELEVISION

20AF43

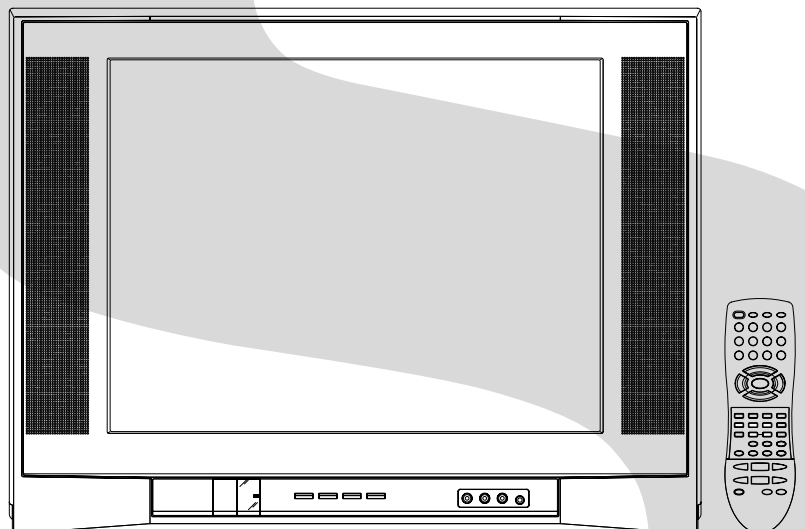

DOCUMENT CREATED IN JAPAN, Mar., 2005

SERVICING NOTICES ON CHECKING

1. KEEP THE NOTICES

As for the places which need special attentions, they are indicated with the labels or seals on the cabinet, chassis and parts. Make sure to keep the indications and notices in the operation manual.

2. AVOID AN ELECTRIC SHOCK

There is a high voltage part inside. Avoid an electric shock while the electric current is flowing.

3. USE THE DESIGNATED PARTS

The parts in this equipment have the specific characters of incombustibility and withstand voltage for safety. Therefore, the part which is replaced should be used the part which has the same character.

Especially as to the important parts for safety which is indicated in the circuit diagram or the table of parts as a  mark, the designated parts must be used.

4. PUT PARTS AND WIRES IN THE ORIGINAL POSITION AFTER ASSEMBLING OR WIRING

There are parts which use the insulation material such as a tube or tape for safety, or which are assembled in the condition that these do not contact with the printed board. The inside wiring is designed not to get closer to the pyrogenic parts and high voltage parts. Therefore, put these parts in the original positions.

5. TAKE CARE TO DEAL WITH THE CATHODE-RAY TUBE

In the condition that an explosion-proof cathode-ray tube is set in this equipment, safety is secured against implosion. However, when removing it or serving from backward, it is dangerous to give a shock. Take enough care to deal with it.

6. AVOID AN X-RAY

Safety is secured against an X-ray by considering about the cathode-ray tube and the high voltage peripheral circuit, etc.

Therefore, when repairing the high voltage peripheral circuit, use the designated parts and make sure not modify the circuit.

Repairing except indicates causes rising of high voltage, and it emits an X-ray from the cathode-ray tube.

7. PERFORM A SAFETY CHECK AFTER SERVICING

Confirm that the screws, parts and wiring which were removed in order to service are put in the original positions, or whether there are the portions which are deteriorated around the serviced places serviced or not. Check the insulation between the antenna terminal or external metal and the AC cord plug blades. And be sure the safety of that.

(INSULATION CHECK PROCEDURE)

1. Unplug the plug from the AC outlet.
2. Remove the antenna terminal on TV and turn on the TV.
3. Insulation resistance between the cord plug terminals and the external exposure metal **[Note 2]** should be more than 1M ohm by using the 500V insulation resistance meter **[Note 1]**.
4. If the insulation resistance is less than 1M ohm, the inspection repair should be required.

[Note 1]

If you have not the 500V insulation resistance meter, use a Tester.

[Note 2]

External exposure metal: Antenna terminal
Earphone jack

HOW TO ORDER PARTS

Please include the following informations when you order parts. (Particularly the VERSION LETTER.)

1. MODEL NUMBER and VERSION LETTER

The MODEL NUMBER can be found on the back of each product and the VERSION LETTER can be found at the end of the SERIAL NUMBER.

2. PART NO. and DESCRIPTION

You can find it in your SERVICE MANUAL.

IMPORTANT

Inferior silicon grease can damage IC's and transistors.

When replacing an IC's or transistors, use only specified silicon grease (YG6260M).

Remove all old silicon before applying new silicon.

TABLE OF CONTENTS

SERVICING NOTICES ON CHECKING	A1-1
HOW TO ORDER PARTS	A1-1
IMPORTANT	A1-1
TABLE OF CONTENTS	A2-1
GENERAL SPECIFICATIONS	A3-1~A3-5
DISASSEMBLY INSTRUCTIONS	
1. REMOVAL OF ANODE CAP	B1-1
2. REMOVAL AND INSTALLATION OF FLAT PACKAGE IC	B2-1, B2-2
SERVICE MODE LIST	C1-1
CONFIRMATION OF HOURS USED	C1-1
WHEN REPLACING EEPROM (MEMORY) IC	C1-1
ELECTRICAL ADJUSTMENTS	D-1~D-5
BLOCK DIAGRAMS	E-1, E-2
PRINTED CIRCUIT BOARDS	
MAIN	F-1~F-4
CRT/VMCOIL	F-5, F-6
SCHEMATIC DIAGRAMS	
MICON	G-1, G-2
CHROMA	G-3, G-4
DEFLECTION	G-5, G-6
POWER	G-7, G-8
SOUND	G-9, G-10
TUNER/STEREO	G-11, G-12
AV	G-13, G-14
COMB/FILTER	G-15, G-16
CRT/SVM	G-17, G-18
WAVEFORMS	H-1, H-2
MECHANICAL EXPLODED VIEWS	I1-1
MECHANICAL REPLACEMENT PARTS LIST	J1-1
ELECTRICAL REPLACEMENT PARTS LIST	J2-1~J2-4

GENERAL SPECIFICATIONS

G-1	TV System	CRT	CRT Size / Visual Size	20 inch / 508mmV	
			CRT Type	Flat	
			Deflection	90 degree	
			Magnetic Field BV/BH	+0.45G/0.18G	
			Color System	NTSC	
			Speaker	2 Speaker	
				Position	Front Side
				Size	2 x 4.7 Inch
				Impedance	8 ohm
			Sound Output	MAX	2.5+2.5 W
		10%(Typical)	2.0+2.0 W		
		NTSC3.58+4.43 /PAL60Hz	No		
G-2	Tuning System	Broadcasting System		US System M	
		Tuner and Receive CH	System	1Tuner	
			Destination	USA(W/ CATV)	
			Tuning System	F-Synth	
			Input Impedance	VHF/UHF 75 ohm	
				CH Coverage	2 - 69, 4A, A-5 - A-1, A - I, J - W, W+1 - W+84
			Intermediate Frequency	Picture(FP)	45.75MHz
				Sound(FS)	41.25MHz
				FP-FS	4.50MHz
			Preset CH		No
G-3	Power	Power Source	AC	120V AC 60Hz	
			DC		
		Power Consumption		at AC	
			Stand by (at AC)		105 W at AC 120 V 60 Hz
			Per Year		3 W at AC 120 V 60 Hz
			-- kWh/Year		
	Protector	Power Fuse		Yes	
G-4	Regulation	Safety		UL/CSA	
		Radiation		FCC/IC	
		X-Radiation		DHHS/HWC	
G-5	Temperature	Operation		+5oC ~ +40oC	
		Storage		-20oC ~ +60oC	
G-6	Operating Humidity			Less than 80% RH	

GENERAL SPECIFICATIONS

G-7	On Screen Display	Menu	Menu Type	Yes		
			Icon	Yes		
			Picture	Yes		
			Contrast	Yes		
			Brightness	Yes		
			Color	Yes		
			Tint	Yes		
			Sharpness	Yes		
			Sound	Yes		
			Bass	Yes		
			Treble	Yes		
			Balance	Yes		
			BBE On/Off	Yes		
			Stable Sound On/Off	Yes		
			Surround On/Off	Yes		
			Set Up	Yes		
			TV/CATV	Yes		
			Auto CH Memory	Yes		
			Add/ Delete	Yes		
			Option	Yes		
			Language	Yes		
			CH Label	Yes		
			Favorite CH	Yes		
			V-Chip	Yes		
			Lock	Yes		
			On/Off Timer	Yes		
			Color Stream DVD/DTV	Yes		
			Control Level	Yes		
			Volume	Yes		
			Brightness	Yes		
			Contrast	Yes		
			Color	Yes		
			Tint (NTSC Only)	Yes		
Sharpness	Yes					
Tuning	No					
Bass	Yes					
Treble	Yes					
Balance	Yes					
Back Light	No					
Stereo,Audio Output,SAP	Yes					
Video	Yes					
Color Stream	Yes					
Channel(TV/Cable)	Yes					
CH Label	Yes					
Game Timer	Yes					
Sleep Timer	Yes					
Sound Mute	Yes					
V-chip Rating	Yes					
16: 9	Yes					
G-8	OSD Language		English	French	Spanish	
G-9	Clock and Timer	Sleep Timer	Max Time	120 Min		
			Step	10 Min		
		On/Off Timer	Program(On Timer / Off Timer / Clock)	Yes		
		Wake Up Timer			No	
	Timer Back-up (at Power Off Mode)	more than	--	Min	Sec	

GENERAL SPECIFICATIONS

G-10	Remote Control	Unit	RC-GF		
		Glow in Dark Remocon	Yes		
		Format	Toshiba		
		Custom Code	TV:40-BFh		
		Power Source	Voltage(D.C) UM size x pcs	3V UM-4 x 2 pcs	
		Total Keys		49 Keys	
		Keys	Power	Yes	
			1	Yes	
			2	Yes	
			3	Yes	
			4	Yes	
			5	Yes	
			6	Yes	
			7	Yes	
			8	Yes	
			9	Yes	
			0	Yes	
			100	Yes	
			CH Up/+	Yes	
			CH Down/-	Yes	
			Volume Up/+	Yes	
			Volume Down/-	Yes	
			C.C.(TV/Caption/Text)	Yes	
			CH1/CH2	Yes	
			TV/Video(Input Select)	Yes	
			CH RTN(Quick View)	Yes	
			SLEEP	Yes	
			RECALL(Call)	Yes	
			Reset	Yes	
			Menu/Enter	Yes	
			Mute	Yes	
			Exit	Yes	
			MTS(Audio Select)	Yes	
			Fav. Up	Yes	
			Fav. Down	Yes	
			16: 9	Yes	
			Multi Brand Keys	CH Up(VCR)	Yes
				CH Down(VCR)	Yes
				Pause/Still	Yes
				TV/VCR(VCR)	Yes
				FF	Yes
				Rew	Yes
				Rec	Yes
				Play	Yes
				Stop	Yes
				TV	Yes
				VCR	Yes
				Cable	Yes
				DVD	Yes
				CODE	Yes
		DVD MENU <	Yes		
		DVD MENU >	Yes		
		DVD CLEAR	Yes		
		TOP MENU	Yes		
		DVD MENU	Yes		

GENERAL SPECIFICATIONS

G-11	Features	Auto Degauss	Yes	
		Auto Shut Off	Yes	
		Canal+	No	
		CATV	Yes	
		Anti-theft	No	
		Rental	No	
		Memory(Last CH)	Yes	
		Memory(Last Volume)	Yes	
		V-Chip	Yes	
		Type	USA, Toshiba Type	
		BBE	Yes	
		Auto Search	No	
		CH Allocation	No	
		SAP	Yes	
		Just Clock Function	No	
		CH Label	Yes	
		VM Circuit	Yes	
		Full OSD	No	
		Premiere	No	
		Comb Filter	Yes	
			3 Lines	
		Auto CH Memory	Yes	
		Hotel Lock	No	
		Closed Caption	Yes	
		Stable Sound	Yes	
		FBT Leak Test Protect	Yes	
		CH Lock	Yes	
		Video Lock	Yes	
		Game Timer (Max Time:120 Min)	Yes	
		Energy Star	Yes	
		Favorite CH	Yes	
		Surround	Yes	
		16:9 Mode	Yes	
G-12	Accessories	Owner's Manual	Language W/ Warranty	English / French
		Remote Control Unit		Yes
		Rod Antenna		No
			Poles Terminal	
		Loop Antenna		No
			Terminal	-
		U/V Mixer		No
		DC Car Cord (Center+)		No
		Guarantee Card		No
		Warning Sheet		No
		Circuit Diagram		No
		Antenna Change Plug		No
		Service Station List		No
		Important Safety Instruction		No
		Dew/AHC Caution Sheet		No
		AC Plug Adapter		No
		Quick Set-up Sheet		No
		Battery		Yes
			UM size x pcs OEM Brand	UM-4 x 2
				No
		AC Cord		No
		AV Cord (2Pin-1Pin)		No
		Registration Card (NDL Card)		Yes
PTB Sheet		No		
ESP Card		Yes		
300 ohm to 75 ohm Antenna Adapter		No		

GENERAL SPECIFICATIONS

G-13	Interface	Switch	Front	Power	Yes
				System Select	No
				Main Power SW	No
				Sub Power	No
				Channel Up	Yes
				Channel Down	Yes
				Volume Up	Yes
		Volume Down	Yes		
		Indicator	Rear	AC/DC	No
				TV/CATV Selector	No
				Degauss	No
				Main Power SW	No
		Indicator	Power	Power	Yes(RED)
				Stand-by	No
				On Timer	No
		Terminals	Front	Video Input = VIDEO3	RCA
				Audio Input = VIDEO3	RCA x 2
				Other Terminal	Head Phone
			Rear	Video Input(Rear1) = VIDEO1	RCA
				Video Input(Rear2) = VIDEO2	RCA
				Audio Input(Rear1) = VIDEO1	RCA x 2
				Audio Input(Rear2) = VIDEO2	RCA x 2
				Video Output	RCA
				Audio Output	RCA x 2
				Euro Scart	No
				Color Stream	RCA x 3
S Input	Yes				
Diversity	No				
Ext Speaker	No				
DC Jack 12V(Center +)	No				
VHF/UHF Antenna Input	F Type				
AC Outlet	No				
G-14	Set Size	Approx. W x D x H (mm)		<u>590 x 484 x 446.5</u>	
G-15	Weight	Net (Approx.)		<u>23 kg (50.6 lbs)</u>	
		Gross (Approx.)		<u>26.5 kg (58.3 lbs)</u>	
G-16	Carton	Master Carton		No	
			Content	---- Sets	
			Material	-- /--	
			Dimensions W x D x H(mm)	-- x -- x --	
		Gift Box	Description of Origin	No	
				Yes	
			Material	Double/Brown	
			Dimensions W x D x H(mm)	<u>695 x 575 x 549</u>	
			Design	As per Buyer's	
			Description of Origin	Yes	
			Drop Test	Natural Dropping At 1 Corner / 3 Edges / 6 Surfaces	
Height (cm)	46				
Container Stuffing	<u>272</u> Sets/40' container				
G-17	Cabinet Material	Cabinet	Cabinet Front	PS 94V0 DECABROM	
			Cabinet Rear	PS 94V0 DECABROM	
		PCB	Non-Halogen Demand	No	
			Eyelet Demand	Yes	

DISASSEMBLY INSTRUCTIONS

1. REMOVAL OF ANODE CAP

Read the following **NOTED** items before starting work.

- * After turning the power off there might still be a potential voltage that is very dangerous. When removing the Anode Cap, make sure to discharge the Anode Cap's potential voltage.
- * Do not use pliers to loosen or tighten the Anode Cap terminal, this may cause the spring to be damaged.

REMOVAL

1. Follow the steps as follows to discharge the Anode Cap. (Refer to Fig. 1-1.)

Connect one end of an Alligator Clip to the metal part of a flat-blade screwdriver and the other end to ground. While holding the plastic part of the insulated Screwdriver, touch the support of the Anode with the tip of the Screwdriver. A cracking noise will be heard as the voltage is discharged.

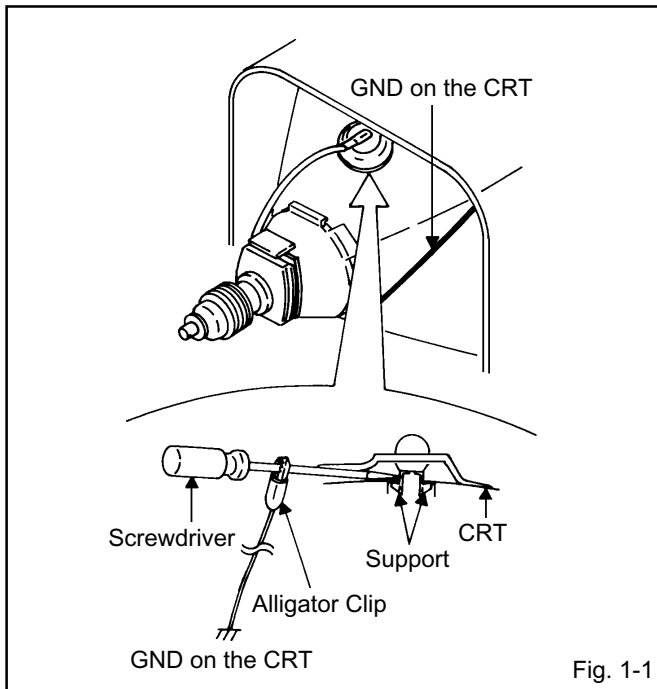

2. Flip up the sides of the Rubber Cap in the direction of the arrow and remove one side of the support. (Refer to Fig. 1-2.)

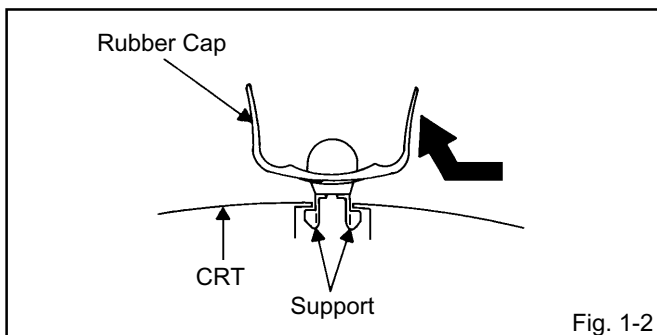

3. After one side is removed, pull in the opposite direction to remove the other.

NOTE

Take care not to damage the Rubber Cap.

INSTALLATION

1. Clean the spot where the cap was located with a small amount of alcohol. (Refer to Fig. 1-3.)

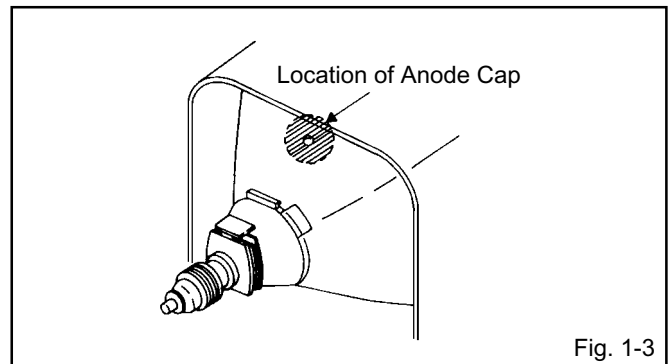

NOTE

Confirm that there is no dirt, dust, etc. at the spot where the cap was located.

2. Arrange the wire of the Anode Cap and make sure the wire is not twisted.
3. Turn over the Rubber Cap. (Refer to Fig. 1-4.)

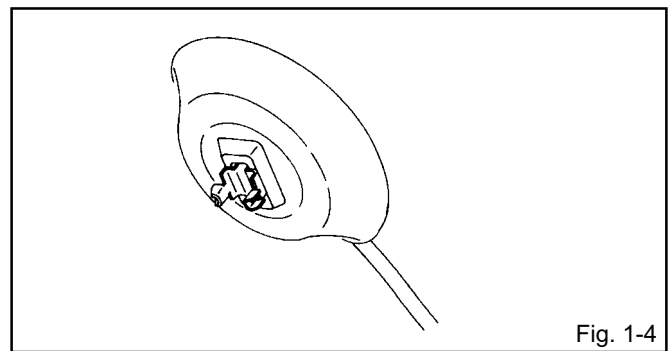

4. Insert one end of the Anode Support into the anode button, then the other as shown in Fig. 1-5.

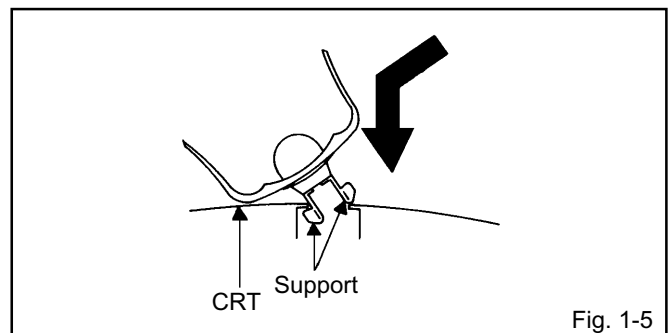

5. Confirm that the Support is securely connected.
6. Put on the Rubber Cap without moving any parts.

DISASSEMBLY INSTRUCTIONS

2. REMOVAL AND INSTALLATION OF FLAT PACKAGE IC

REMOVAL

1. Put the Masking Tape (cotton tape) around the Flat Package IC to protect other parts from any damage. (Refer to Fig. 2-1.)

NOTE

Masking is carried out on all the parts located within 10 mm distance from IC leads.

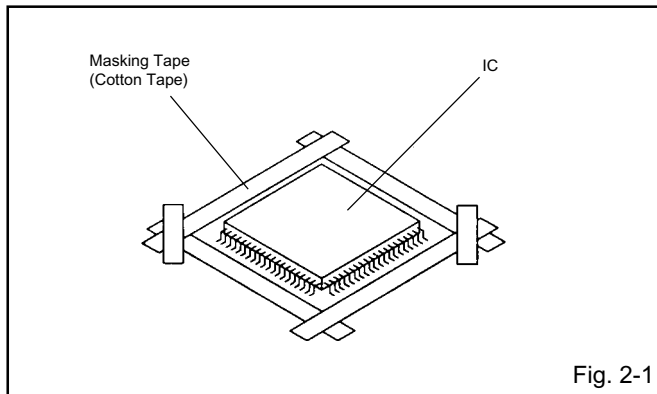

2. Heat the IC leads using a blower type IC desoldering machine. (Refer to Fig. 2-2.)

NOTE

Do not add the rotating and the back and forth directions force on the IC, until IC can move back and forth easily after desoldering the IC leads completely.

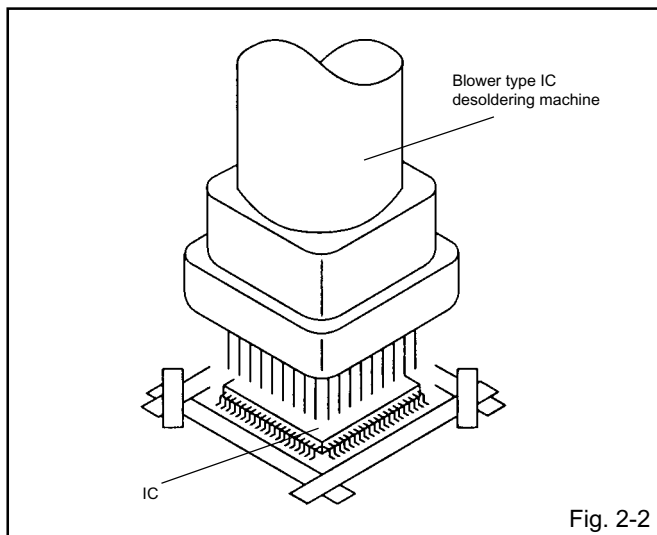

3. When IC starts moving back and forth easily after desoldering completely, pickup the corner of the IC using a tweezers and remove the IC by moving with the IC desoldering machine. (Refer to Fig. 2-3.)

NOTE

Some ICs on the PCB are affixed with glue, so be careful not to break or damage the foil of each IC leads or solder lands under the IC when removing it.

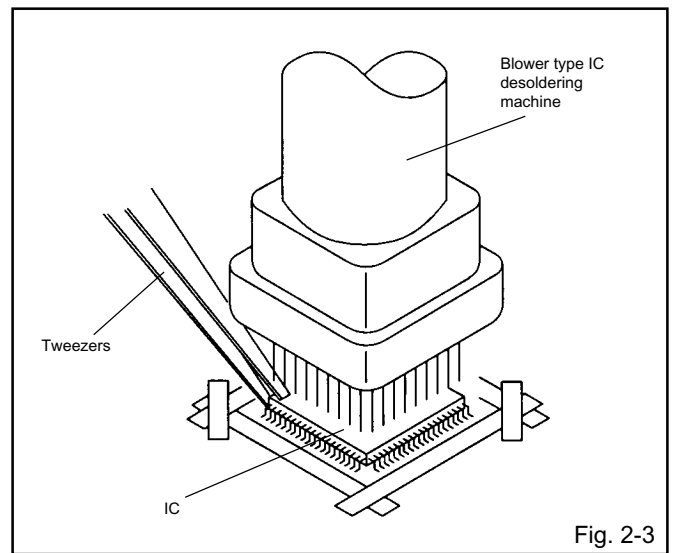

4. Peel off the Masking Tape.

5. Absorb the solder left on the pattern using the Braided Shield Wire. (Refer to Fig. 2-4.)

NOTE

Do not move the Braided Shield Wire in the vertical direction towards the IC pattern.

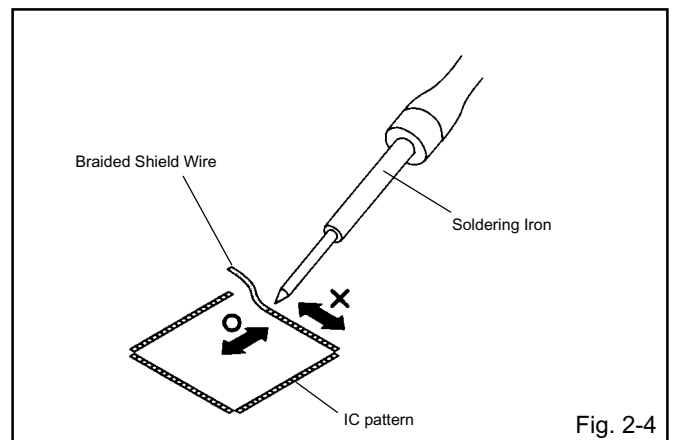

DISASSEMBLY INSTRUCTIONS

INSTALLATION

1. Take care of the polarity of new IC and then install the new IC fitting on the printed circuit pattern. Then solder each lead on the diagonal positions of IC temporarily. (Refer to Fig. 2-5.)

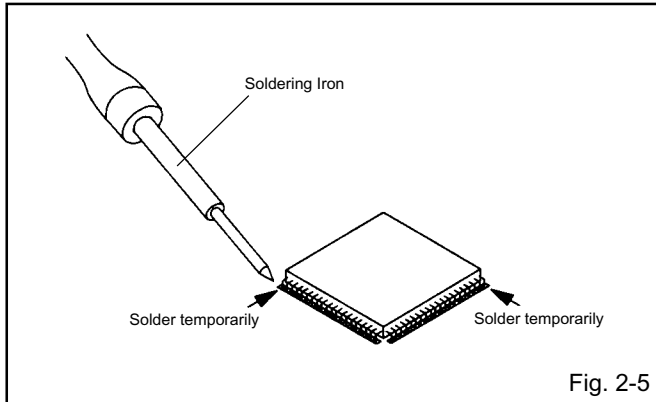

2. Supply the solder from the upper position of IC leads sliding to the lower position of the IC leads. (Refer to Fig. 2-6.)

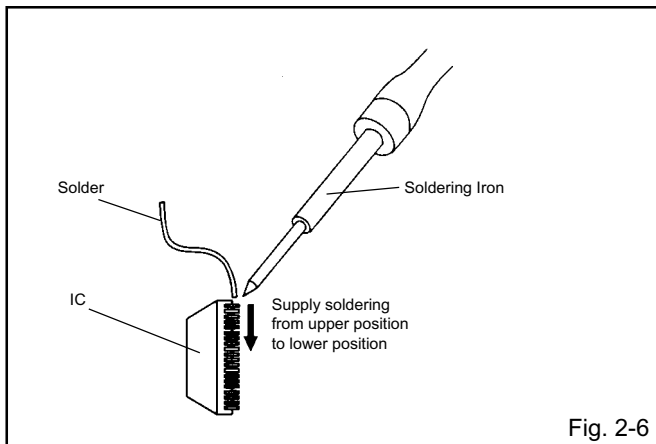

3. Absorb the solder left on the lead using the Braided Shield Wire. (Refer to Fig. 2-7.)

NOTE

Do not absorb the solder to excess.

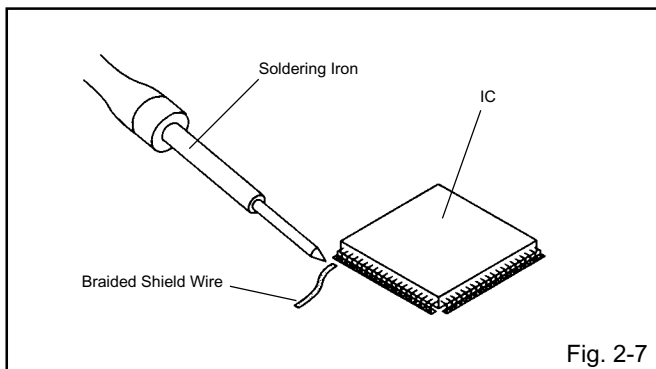

4. When bridge-soldering between terminals and/or the soldering amount are not enough, resolder using a Thin-tip Soldering Iron. (Refer to Fig. 2-8.)

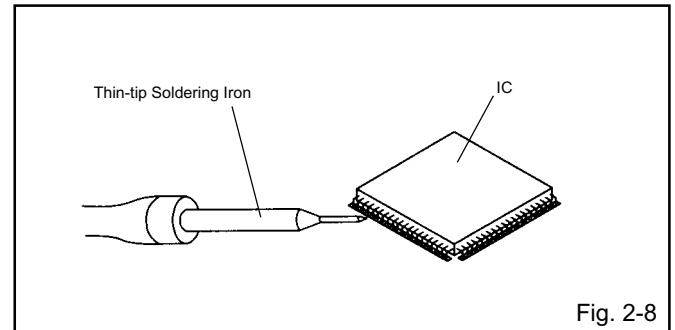

5. Finally, confirm the soldering status on four sides of the IC using a magnifying glass. Confirm that no abnormality is found on the soldering position and installation position of the parts around the IC. If some abnormality is found, correct by resoldering.

NOTE

When the IC leads are bent during soldering and/or repairing, do not repair the bending of leads. If the bending of leads are repaired, the pattern may be damaged. So, be always sure to replace the IC in this case.

SERVICE MODE LIST

This unit provided with the following SERVICE MODES so you can repair, examine and adjust easily. To enter the Service Mode, press both set key and remote control key for more than 1 second.

Set Key	Remocon Key	Operations
VOL. (-) MIN	0	Releasing of V-CHIP PASSWORD.
VOL. (-) MIN	1	Initialization of the factory. NOTE: Do not use this for the normal servicing. If you set a factory initialization, the memories are reset such as the channel setting, and the POWER ON total hours.
VOL. (-) MIN	6	POWER ON total hours is displayed on the screen. Refer to the "CONFIRMATION OF HOURS USED". Can be checked of the INITIAL DATA of MEMORY IC. Refer to the "WHEN REPLACING EEPROM (MEMORY) IC".
VOL. (-) MIN	8	Writing of EEPROM initial data. NOTE: Do not use this for the normal servicing.
VOL. (-) MIN	9	Display of the Adjustment MENU on the screen. Refer to the "ELECTRICAL ADJUSTMENT" (On-Screen Display Adjustment).

CONFIRMATION OF HOURS USED

POWER ON total hours can be checked on the screen. Total hours are displayed in 16 system of notation.

NOTE: If you set a factory initialization, the total hours is reset to "0".

1. Set the VOLUME to minimum.
2. Press both VOL. DOWN button on the set and Channel button (6) on the remote control for more than 1 second.
3. After the confirmation of using hours, turn off the power.

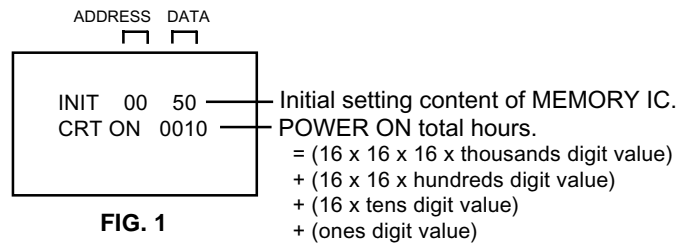

WHEN REPLACING EEPROM (MEMORY) IC

If a service repair is undertaken where it has been required to change the MEMORY IC, the following steps should be taken to ensure correct data settings while making reference to TABLE 1.

NOTE: No need setting for after INI 1F due to the adjustment value.

INI	+0	+1	+2	+3	+4	+5	+6	+7	+8	+9	+A	+B	+C	+D	+E	+F
00	50	E8	0A	45	5E	B3	24	B7	3D	AC	0A	04	40	40	40	7F
10	50	00	00	00	00	00	00	00	3F	0F	0D	C2	94	88	42	00

Table 1

1. Enter DATA SET mode by setting VOLUME to minimum.
2. Press both VOL. DOWN button on the set and Channel button (6) on the remote control for more than 1 second. ADDRESS and DATA should appear as FIG 1.
3. ADDRESS is now selected and should "blink". Using the VOL. UP/DOWN button on the remote, step through the ADDRESS until required ADDRESS to be changed is reached.
4. Press ENTER to select DATA. When DATA is selected, it will "blink".
5. Again, step through the DATA using VOL. UP/DOWN button until required DATA value has been selected.
6. Pressing ENTER will take you back to ADDRESS for further selection if necessary.
7. Repeat steps 3 to 6 until all data has been checked.
8. When satisfied correct DATA has been entered, turn POWER off (return to STANDBY MODE) to finish DATA input.
After the data input, set to the initializing of shipping.
9. Turn POWER on.
10. Press both VOL. DOWN button on the set and Channel button (1) on the remote control for more than 1 second.
11. After the finishing of the initializing of shipping, the unit will turn off automatically.
The unit will now have the correct DATA for the new MEMORY IC.

ELECTRICAL ADJUSTMENTS

1. BEFORE MAKING ELECTRICAL ADJUSTMENTS

Read and perform these adjustments when repairing the circuits or replacing electrical parts or PCB assemblies.

CAUTION

- Use an isolation transformer when performing any service on this chassis.
- Before removing the anode cap, discharge electricity because it contains high voltage.
- When removing a PCB or related component, after unfastening or changing a wire, be sure to put the wire back in its original position.
- When you exchange IC and Transistor for a heat sink, apply the silicon grease on the contact section of the heat sink. Before applying new silicon grease, remove all the old silicon grease. (Old grease may cause damages to the IC and Transistor.)

Prepare the following measurement tools for electrical adjustments.

1. Oscilloscope
2. Digital Voltmeter
3. Multi-sound Generator
4. Pattern Generator

On-Screen Display Adjustment

1. In the condition of NO indication on the screen. Press the VOL. DOWN button on the set and the Channel button (9) on the remote control for more than 1 second to appear the adjustment mode on the screen as shown in Fig. 1-1.

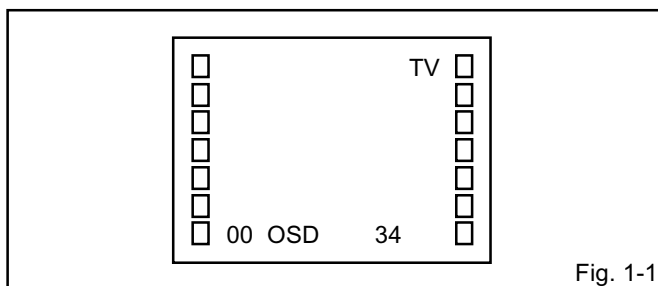

Fig. 1-1

2. Use the Channel UP/DOWN button or Channel button (0-9) on the remote control to select the options shown in Fig. 1-2.
3. Press the MENU button on the remote control to end the adjustments.

NO.	FUNCTION	NO.	FUNCTION	NO.	FUNCTION
00	OSD H	13	G BIAS	26	CB DELAY FINE
01	CUT OFF	14	B BIAS	27	CR DELAY FINE
02	H.VCO	15	BRIGHT MAX	28	CB PEDESTAL ADJ
03	H.PHASE	16	BRIGHT CENT	29	CR PEDESTAL ADJ
04	AFC GAIN	17	BRIGHT MIN	30	E/W PARABOLA
05	V.SHIFT	18	CONTRAST MAX	31	E/W CORNER
06	H.SIZE	19	CONTRAST CENT	32	E/W TRAPEZIUM
07	V.SIZE	20	CONTRAST MIN	33	LEVEL
08	V.LINEARITY	21	COLOR MAX	34	SEPARATION 1
09	VS CORRECTION	22	COLOR CENT	35	SEPARATION 2
10	R DRIVE	23	COLOR MIN		
11	B DRIVE	24	TINT		
12	R BIAS	25	SHARPNESS		

Fig. 1-2

2. BASIC ADJUSTMENTS

2-1: CONSTANT VOLTAGE

1. Place the set with Aging Test for more than 5 minutes.
2. Set condition is AV MODE without signal.
3. Using the remote control, set the brightness and contrast to normal position.
4. Connect the digital voltmeter to the TP003.
5. Adjust the VR502 until the digital voltmeter is $115 \pm 1V$.

2-2: CUT OFF

1. Place the set with Aging Test for more than 15 minutes.
2. Activate the adjustment mode display of Fig. 1-1 and press the channel button (01) on the remote control to select "CUT OFF".
3. Adjust the Screen Volume until a dim raster is obtained.

2-3: WHITE BALANCE

NOTE: Adjust after performing CUT OFF adjustment.

1. Place the set with Aging Test for more than 10 minutes.
2. Receive the gray scale pattern from the Pattern Generator.
3. Using the remote control, set the brightness and contrast to normal position.
4. Activate the adjustment mode display of Fig. 1-1 and press the channel button (10) on the remote control to select "R. DRIVE".
5. Press the CH. UP/DOWN button on the remote control to select the "R. BIAS", "G. BIAS", "B. BIAS", "R. DRIVE" or "B. DRIVE".
6. Adjust the VOL. UP/DOWN button on the remote control to whiten the R. BIAS, G. BIAS, B. BIAS, R. DRIVE, and B. DRIVE at each step tone sections equally.
7. Perform the above adjustments 5 and 6 until the white color is looked like a white.

2-4: FOCUS

1. Receive a broadcast.
2. Turn the Focus Volume fully counterclockwise once.
3. Adjust the Focus Volume until picture is distinct.

2-5: HORIZONTAL POSITION

1. Receive the monoscope pattern.
2. Using the remote control, set the brightness and contrast to normal position.
3. Activate the adjustment mode display of Fig. 1-1 and press the channel button (03) on the remote control to select "H.PHAS".
4. Press the VOL. UP/DOWN button on the remote control until the SHIFT quantity of the OVER SCAN on right and left becomes minimum.

2-6: VERTICAL POSITION

1. Receive the monoscope pattern.
2. Using the remote control, set the brightness and contrast to normal position.
3. Check if the step No. V. SHIFT is "02".
4. Adjust the VR401 until the horizontal line becomes fit to the notch of the shadow mask.

ELECTRICAL ADJUSTMENTS

2-7: VERTICAL SIZE

1. Receive the monoscope pattern.
2. Using the remote control, set the brightness and contrast to normal position.
3. Activate the adjustment mode display of **Fig. 1-1** and press the channel button **(07)** on the remote control to select "V.SIZE".
4. Press the VOL. UP/DOWN button on the remote control until the SHIFT quantity of the OVER SCAN on upside and downside becomes $9 \pm 2\%$.
5. Receive a broadcast and check if the picture is normal.

2-8: VERTICAL LINEARITY

NOTE: Adjust after performing adjustments in section 2-7. After the adjustment of Vertical Linearity, reconfirm the Vertical Position and Vertical Size adjustments.

1. Receive the monoscope pattern.
2. Using the remote control, set the brightness and contrast to normal position.
3. Activate the adjustment mode display of **Fig. 1-1** and press the channel button **(08)** on the remote control to select "V.LIN".
4. Press the VOL. UP/DOWN button on the remote control until the SHIFT quantity of the OVER SCAN on upside and downside becomes minimum.

2-9: SUB BRIGHTNESS

1. Activate the adjustment mode display of **Fig. 1-1** and press the channel button **(16)** on the remote control to select "BRI. CENT".
2. Press the VOL. UP/DOWN button on the remote control until the brightness step No. becomes "98".
3. Receive a broadcast and check if the picture is normal.
4. Press the TV/VIDEO button on the remote control to set to the AV mode. Then perform the above adjustments 1~3.
5. Press the TV/VIDEO button on the remote control to set to the CS mode. Then perform the above adjustments 1~3.

2-10: SUB TINT/SUB COLOR

1. Receive the color bar pattern. (RF Input)
2. Connect the oscilloscope to **TP806**.
3. Using the remote control, set the brightness, contrast, color and tint to normal position.
4. Activate the adjustment mode display of **Fig. 1-1** and press the channel button **(24)** on the remote control to select "TINT".
5. Press the VOL. UP/DOWN button on the remote control until the section "A" becomes a straight line (**Refer to Fig. 2-1**).
6. Connect the oscilloscope to **TP804**.
7. Press the CH DOWN button 2 times to set to "COL. CENT" mode.
8. Adjust the VOLTS RANGE VARIABLE knob of the oscilloscope until the range between white 100% and 0% is set to 5 scales on the screen of the oscilloscope.
9. Press the VOL. UP/DOWN button on the remote control until the red color level is adjusted to $120 \pm 10\%$ of the white level. (**Refer to Fig. 2-2**)
10. Receive the color bar pattern. (Audio Video Input)
11. Press the TV/VIDEO button on the remote control to set to the AV mode. Then perform the above adjustments 2~9.
12. Press the TV/VIDEO button on the remote control to set to the CS mode.
13. Activate the adjustment mode display of **Fig. 1-1** and press the channel button **(24)** on the remote control to select "TINT".
14. Press the VOL. UP/DOWN button on the remote control until the tint step No. becomes "53".
15. Press the CH DOWN button 2 times to set to "COL.CENT" mode.
16. Press the VOL. UP/DOWN button on the remote control until the color step No. becomes "69".

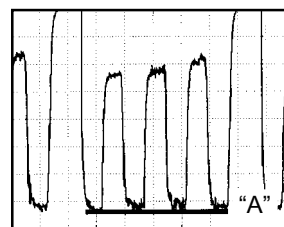

Fig. 2-1

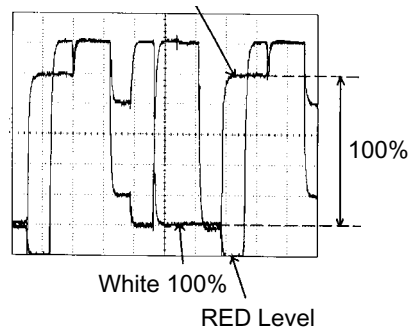

Fig. 2-2

ELECTRICAL ADJUSTMENTS

2-11: SUB CONTRAST

1. Activate the adjustment mode display of **Fig. 1-1** and press the channel button **(18)** on the remote control to select "CONT.MAX".
2. Press the VOL. UP/DOWN button on the remote control until the contrast step No. becomes "81".
3. Receive a broadcast and check if the picture is normal.
4. Press the TV/VIDEO button on the remote to set to the AV mode.
5. Activate the adjustment mode display of **Fig. 1-1** and press the channel button **(18)** on the remote control to select "CONT.MAX".
6. Press the VOL. UP/DOWN button on the remote control until the contrast step No. becomes "84".
7. Receive a broadcast and check if the picture is normal.
8. Press the TV/VIDEO button on the remote to set to the CS mode.
9. Activate the adjustment mode display of **Fig. 1-1** and press the channel button **(18)** on the remote control to select "CONT.MAX".
10. Press the VOL. UP/DOWN button on the remote control until the contrast step No. becomes "86".
11. Receive a broadcast and check if the picture is normal.

2-12: SEPARATION 1, 2

Please do the method (1) or method (2) adjustment.

Method (1)

1. Set the multi-sound signal generator for each different L-ch and R-ch frequency (Ex. L-ch=2KHz, R-ch=400Hz) and receive the RF.
2. Connect the oscilloscope to the **Audio Out Jack**.
3. Activate the adjustment mode display of **Fig. 1-1** and press the channel button **(34)** on the remote control to select "SEP 1".
4. Press the VOL. UP/DOWN button on the remote control to adjust it until the audio output wave becomes a fine sine wave.
5. Press the CH UP button once the set to "SEP 2" mode. Then perform the above adjustment 4.

Method (2)

1. Set the multi-sound signal generator L-ch=1KHz, R-ch=Non input and receive the RF.
2. Connect the oscilloscope to the **Audio Out Jack (R-ch)**.
3. Press the AUDIO SELECT button on the remote control to set to the stereo mode.
4. Activate the adjustment mode display of **Fig. 1-1** and press the channel button **(34)** on the remote control to select "SEP 1".
5. Press the VOL. UP/DOWN button on the remote control to adjust it until the R-ch output becomes minimum.
6. Set the multi-sound signal generator L-ch=Non input, R-ch=1KHz and receive the RF.
7. Connect the oscilloscope to the **Audio Out Jack (L-ch)**.
8. Activate the adjustment mode display of **Fig. 1-1** and press the channel button **(35)** on the remote control to select "SEP 2".
9. Press the VOL. UP/DOWN button on the remote control to adjust it until the L-ch output becomes minimum.

2-13: LEVEL

1. Receive the monoscope pattern (70dB).
2. Connect the AC voltmeter to **pin 6 of CP101**.
3. Activate the adjustment mode display of **Fig. 1-1** and press the channel button **(33)** on the remote control to select "LEVEL".
4. Press the VOL. UP/DOWN button on the remote control until the AC voltmeter is $85 \pm 2\text{mV}$.

2-14: Confirmation of Fixed Value (step No.)

Please check if the fixed values of the each adjustment items are set correctly referring below.

NO.	FUNCTION	STEP NO.
00	OSD H	25
02	H.VCO	03
04	AFC GAIN	04
05	V.SHIFT	02
06	H.SIZE	01
09	VS CORRECTION	38
15	BRIGHT MAX	125
17	BRIGHT MIN	75
19	CONTRAST CENT	50
20	CONTRAST MIN	18
21	COLOR MAX	90
23	COLOR MIN	00
25	SHARPNESS	40
26	CB DELAY FINE	00
27	CR DELAY FINE	00
28	CB PEDESTAL ADJ	08
29	CR PEDESTAL ADJ	08
30	E/W PARABOLA	31
31	E/W CORNER	31
32	E/W TRAPEZIUM	31

ELECTRICAL ADJUSTMENTS

3. PURITY AND CONVERGENCE ADJUSTMENTS

NOTE

1. Turn the unit on and let it warm up for at least 30 minutes before performing the following adjustments.
2. Place the CRT surface facing east or west to reduce the terrestrial magnetism.
3. Turn ON the unit and demagnetize with a Degauss Coil.

3-1: STATIC CONVERGENCE (ROUGH ADJUSTMENT)

1. Tighten the screw for the magnet. Refer to the adjusted CRT for the position. **(Refer to Fig. 3-1)**
If the deflection yoke and magnet are in one body, untighten the screw for the body.
2. Receive the green raster pattern from the color bar generator.
3. Slide the deflection yoke until it touches the funnel side of the CRT.
4. Adjust center of screen to green, with red and blue on the sides, using the pair of purity magnets.
5. Switch the color bar generator from the green raster pattern to the crosshatch pattern.
6. Combine red and blue of the 3 color crosshatch pattern on the center of the screen by adjusting the pair of 4 pole magnets.
7. Combine red/blue (magenta) and green by adjusting the pair of 6 pole magnets.
8. Adjust the crosshatch pattern to change to white by repeating steps 6 and 7.

3-2: PURITY

NOTE

Adjust after performing adjustments in section 3-1.

1. Receive the green raster pattern from color bar generator.
2. Adjust the pair of purity magnets to center the color on the screen.
Adjust the pair of purity magnets so the color at the ends are equally wide.
3. Move the deflection yoke backward (to neck side) slowly, and stop it at the position when the whole screen is green.
4. Confirm red and blue color.
5. Adjust the slant of the deflection yoke while watching the screen, then tighten the fixing screw.

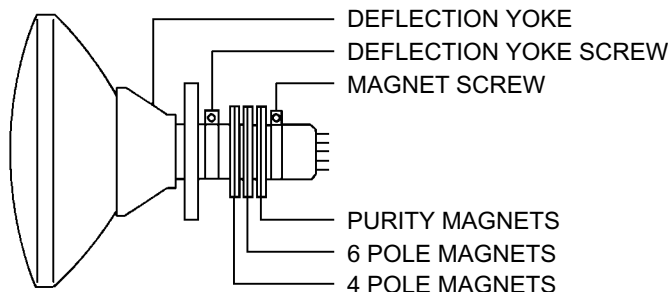

Fig. 3-1

3-3: STATIC CONVERGENCE

NOTE

Adjust after performing adjustments in section 3-2.

1. Receive the crosshatch pattern from the color bar generator.
2. Combine red and blue of the 3 color crosshatch pattern on the center of the screen by adjusting the pair of 4 pole magnets.
3. Combine red/blue (magenta) and green by adjusting the pair of 6 pole magnets.

3-4: DYNAMIC CONVERGENCE

NOTE

Adjust after performing adjustments in section 3-3.

1. Adjust the differences around the screen by moving the deflection yoke upward/downward and right/left. **(Refer to Fig. 3-2-a)**
2. Insert three wedges between the deflection yoke and CRT funnel to fix the deflection yoke. **(Refer to Fig. 3-2-b)**

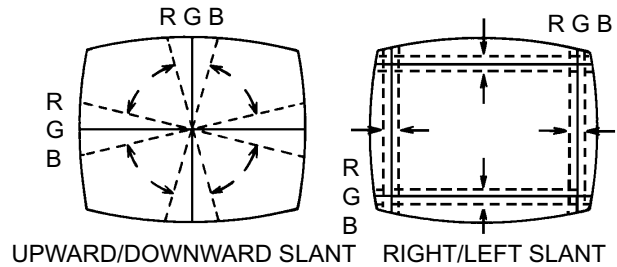
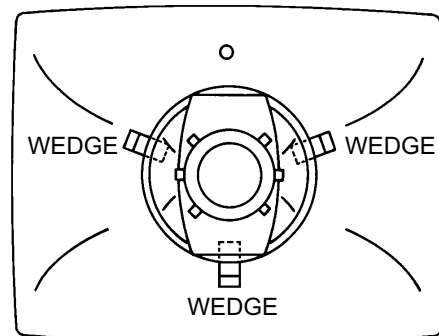

Fig. 3-2-a



WEDGE POSITION

Fig. 3-2-b

ELECTRICAL ADJUSTMENTS

4. ELECTRICAL ADJUSTMENT PARTS LOCATION GUIDE (WIRING CONNECTION)

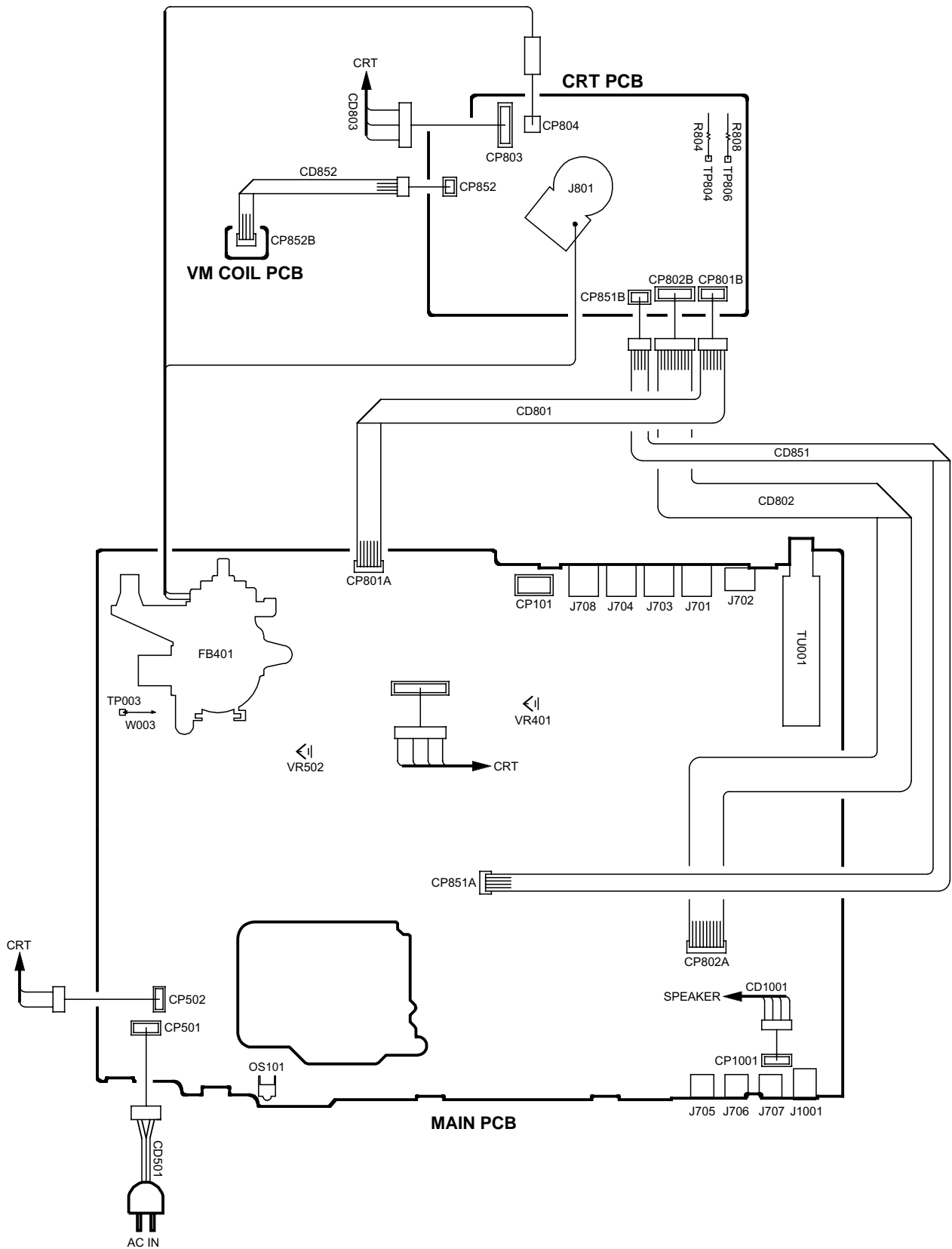

BLOCK DIAGRAM

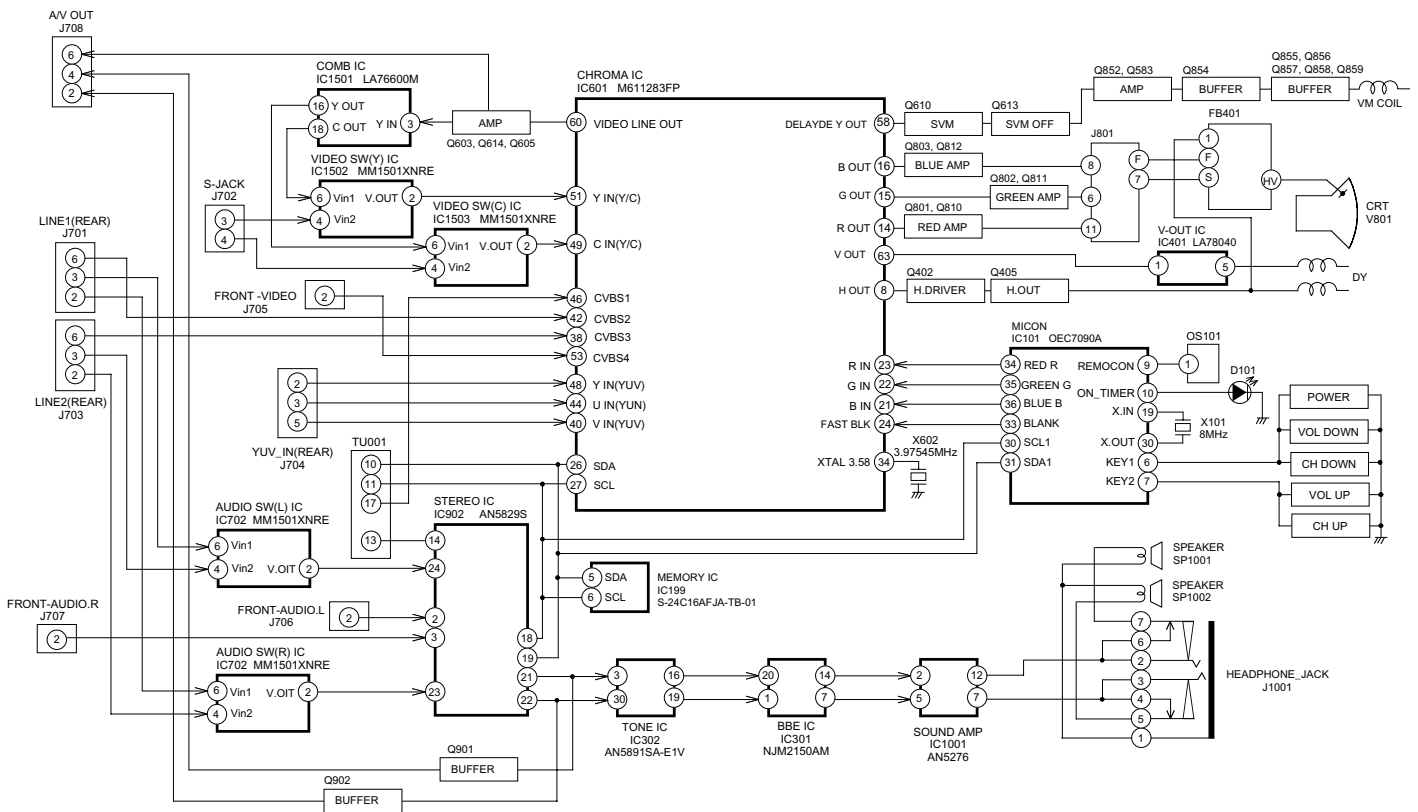

PRINTED CIRCUIT BOARDS
MAIN (INSERTED PARTS)
SOLDER SIDE

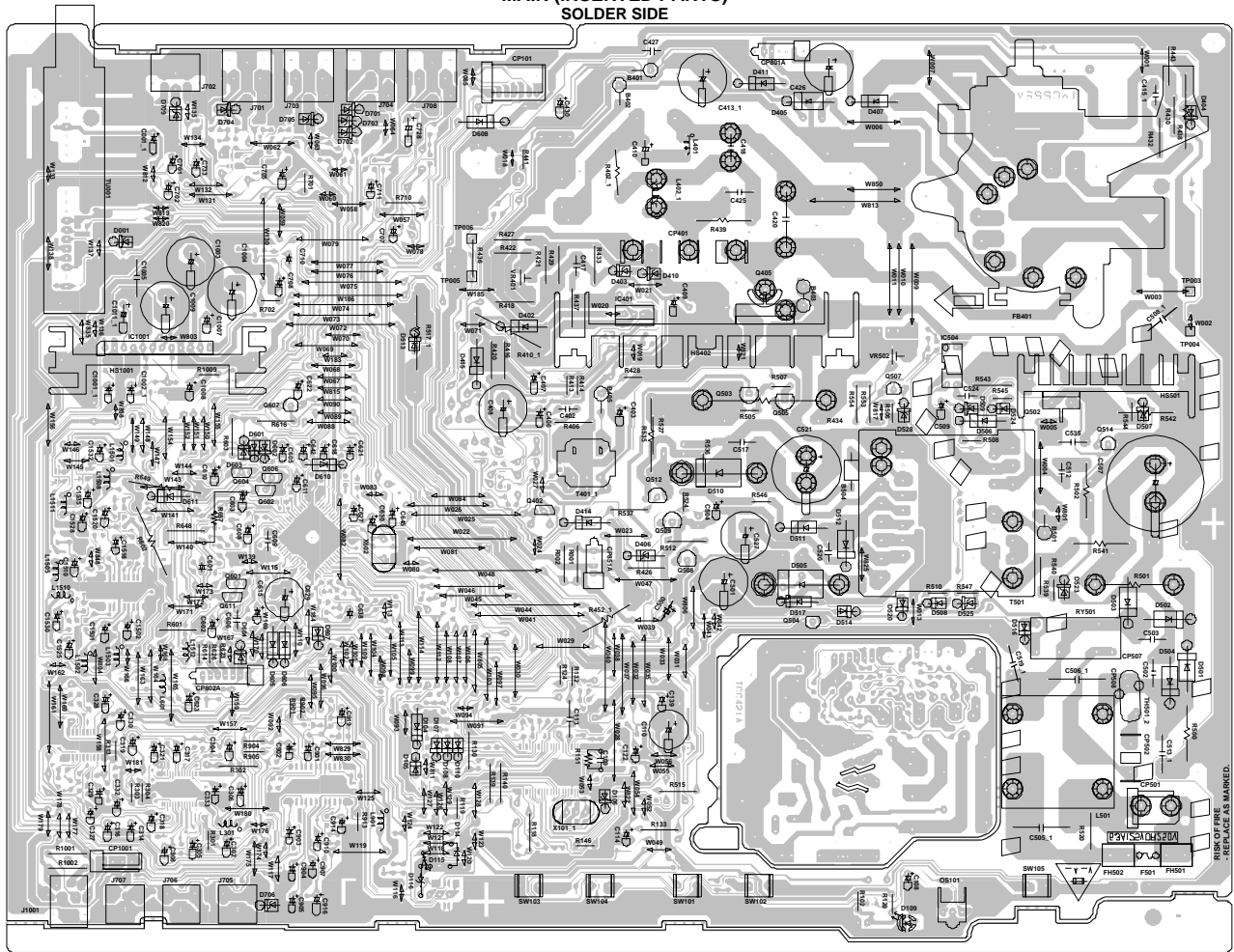

PRINTED CIRCUIT BOARDS
MAIN (CHIP MOUNTED PARTS)
SOLDER SIDE

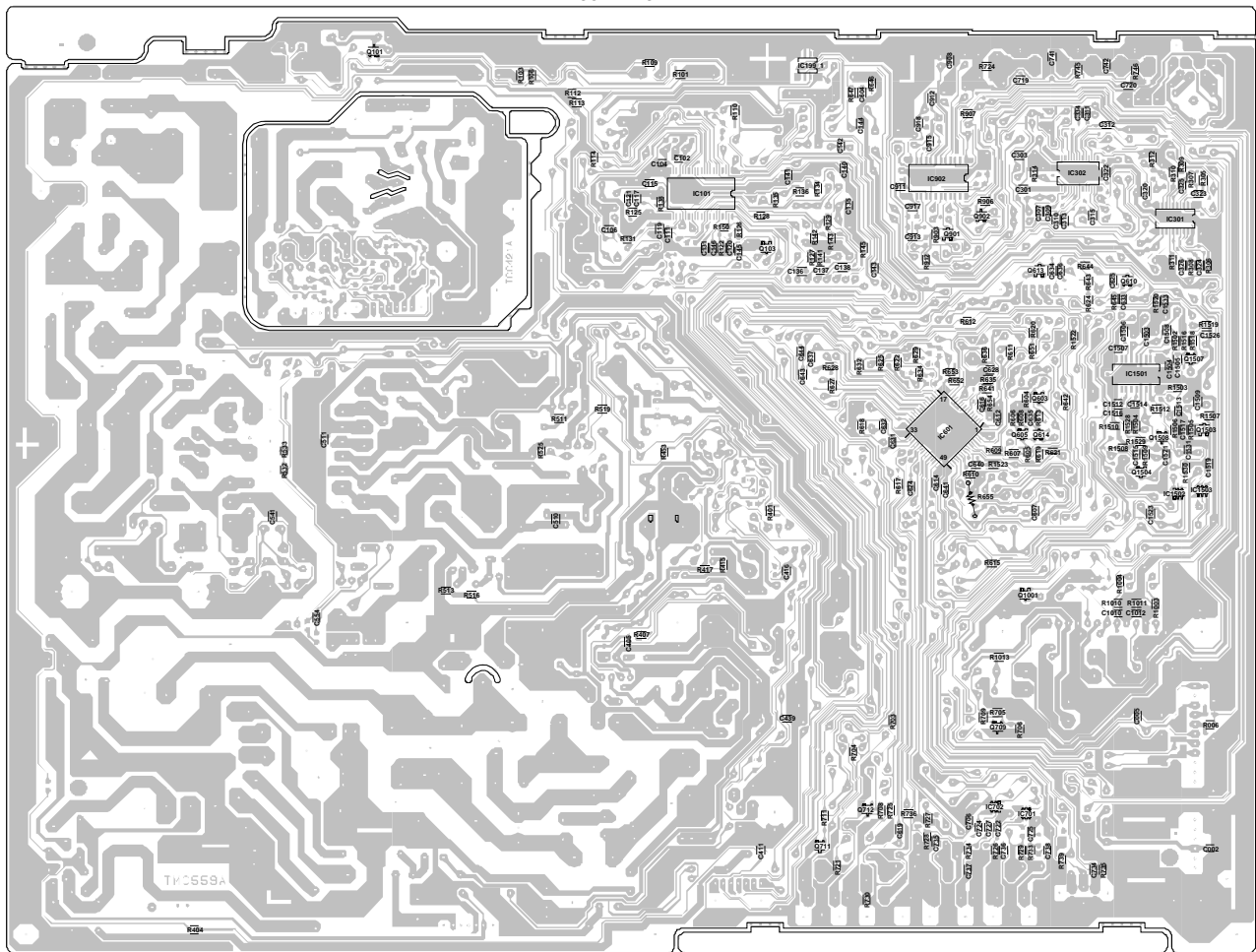

PRINTED CIRCUIT BOARDS

CRT/VM COIL
SOLDER SIDE

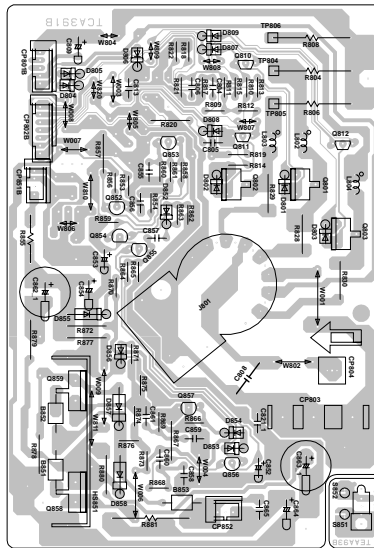

MICON SCHEMATIC DIAGRAM (MAIN PCB)

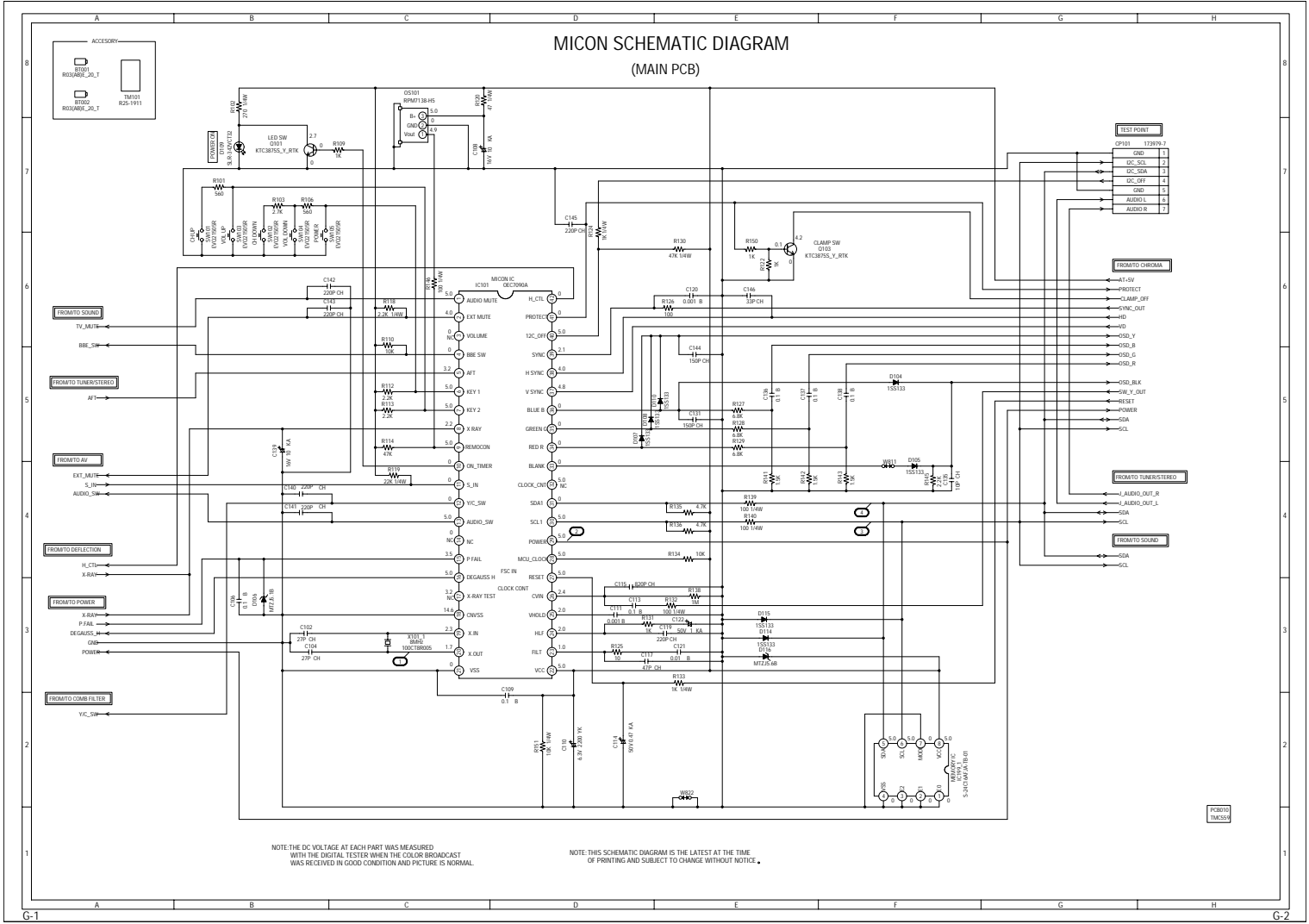

CHROMA SCHEMATIC DIAGRAM (MAIN PCB)

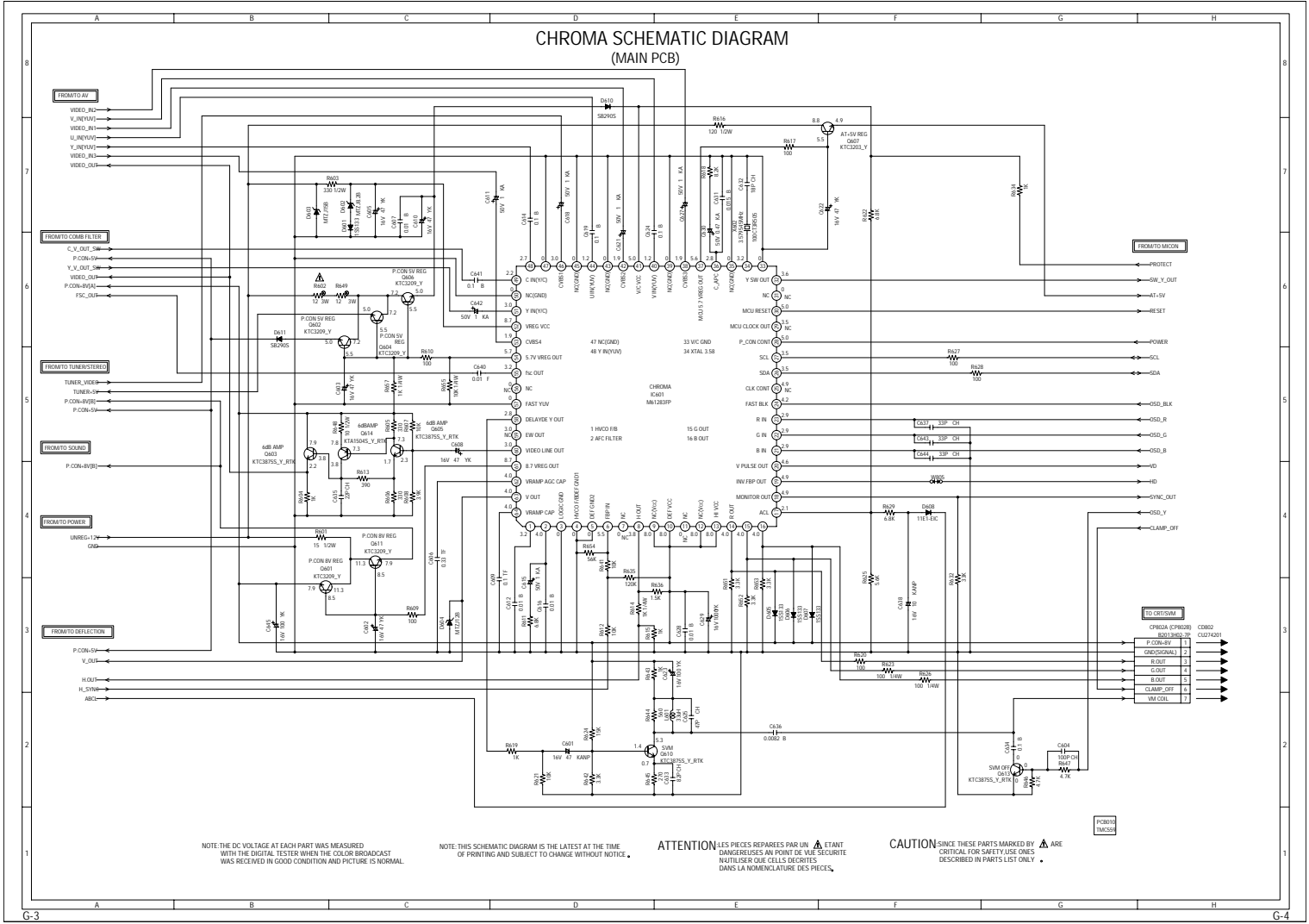

NOTE: THE DC VOLTAGE AT EACH PART WAS MEASURED WITH THE DIGITAL TESTER WHEN THE COLOR BROADCAST WAS RECEIVED IN GOOD CONDITION AND PICTURE IS NORMAL.

NOTE: THIS SCHEMATIC DIAGRAM IS THE LATEST AT THE TIME OF PRINTING AND SUBJECT TO CHANGE WITHOUT NOTICE.

ATTENTION - LES PIÈCES RÉPARÉES PAR UN ÉTANT DANGEREUSES À UN POINT DE VUE SÉCURITÉ, N'UTILISEZ QUE CELLES DES PIÈCES DANS LA NOMÉCLATURE DES PIÈCES.

CAUTION - SINCE THESE PARTS MARKED BY ARE CRITICAL FOR SAFETY, USE ONES DESCRIBED IN PARTS LIST ONLY.

PCB016
TMS334

DEFLECTION SCHEMATIC DIAGRAM (MAIN PCB)

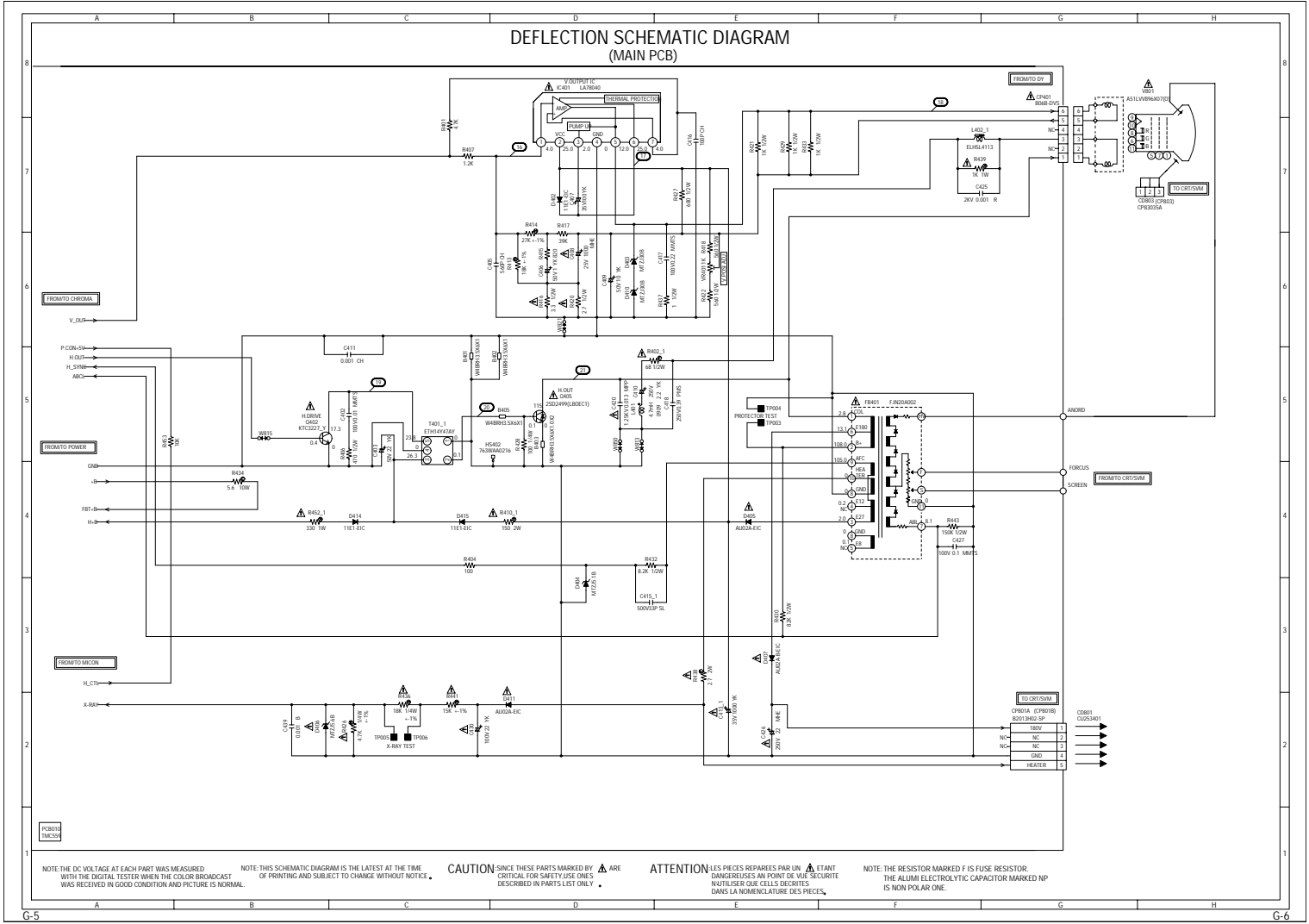

NOTE: THE DC VOLTAGE AT EACH PART WAS MEASURED WITH THE DIGITAL TESTER WHEN THE COLOR BROADCAST WAS RECEIVED IN GOOD CONDITION AND PICTURE IS NORMAL.

NOTE: THIS SCHEMATIC DIAGRAM IS THE LATEST AT THE TIME OF PRINTING AND SUBJECT TO CHANGE WITHOUT NOTICE.

CAUTION SINCE THESE PARTS MARKED WITH ARE CRITICAL FOR SAFETY USE ONLY DESCRIBED IN PARTS LIST ONLY.

ATTENTION LES PIÈCES RÉPARÉES PAR UN ÉTANT DANGEREUSES AU POINT DE VUE SÉCURITÉ UTILISER QUE CELLES DÉCRITES DANS LA NOMÉNCLATURE DES PIÈCES.

NOTE: THE RESISTOR MARKED F IS FUSE RESISTOR. THE ALUMINUM ELECTROLYTIC CAPACITOR MARKED NP IS NON POLAR ONE.

POWER SCHEMATIC DIAGRAM (MAIN PCB)

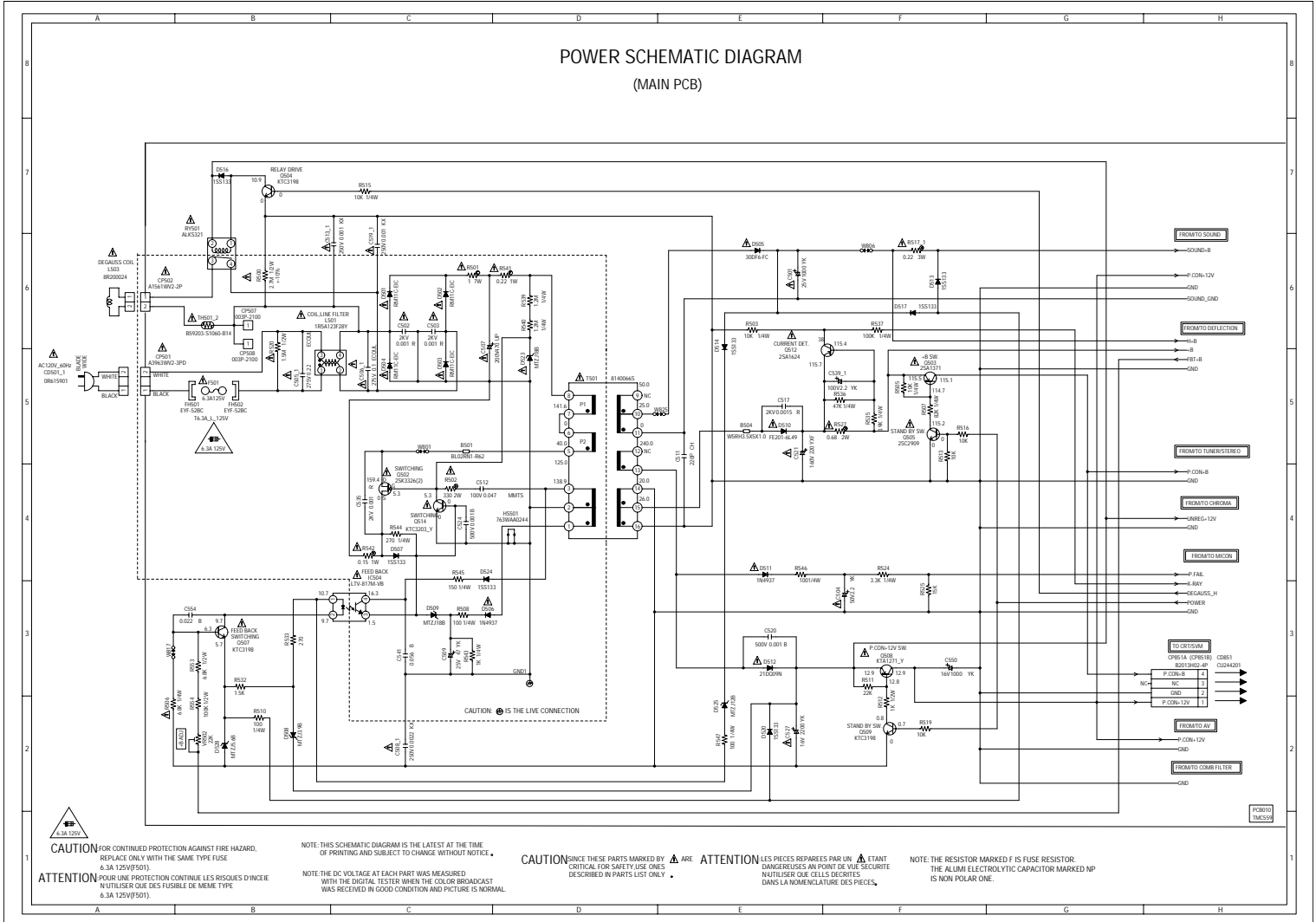

CAUTION ⚡ FOR CONTINUED PROTECTION AGAINST FIRE HAZARD, REPLACE ONLY WITH THE SAME TYPE FUSE
6.3A 125V(F501)

ATTENTION ⚡ POUR UNE PROTECTION CONTINUE LES RISQUES D'INCENDIE N'UTILISER QUE DES FUSIBLES DE MEME TYPE
6.3A 125V(F501)

NOTE: THIS SCHEMATIC DIAGRAM IS THE LATEST AT THE TIME OF PRINTING AND SUBJECT TO CHANGE WITHOUT NOTICE.

NOTE: THE DC VOLTAGE AT EACH PART WAS MEASURED WITH THE DIGITAL TESTER WHEN THE COLOR BROADCAST WAS RECEIVED IN GOOD CONDITION AND PICTURE IS NORMAL.

CAUTION ⚡ SINCE THESE PARTS MARKED BY ⚡ ARE CRITICAL, FOR SAFETY USE ONLY DESCRIBED IN PARTS LIST ONLY.

ATTENTION ⚡ LES PIÈCES MARQUÉES PAR UN ⚡ ÉTAIENT DANGEREUSES AU POINT DE VUE SÉCURITÉ. N'UTILISER QUE CELLES DÉCRITES DANS LA NOMÉNCLATURE DES PIÈCES.

NOTE: THE RESISTOR MARKED F IS FUSE RESISTOR. THE ALUMINUM ELECTROLYTIC CAPACITOR MARKED HP IS NON POLAR ONE.

PC0610
TRACKS

SOUND SCHEMATIC DIAGRAM (MAIN PCB)

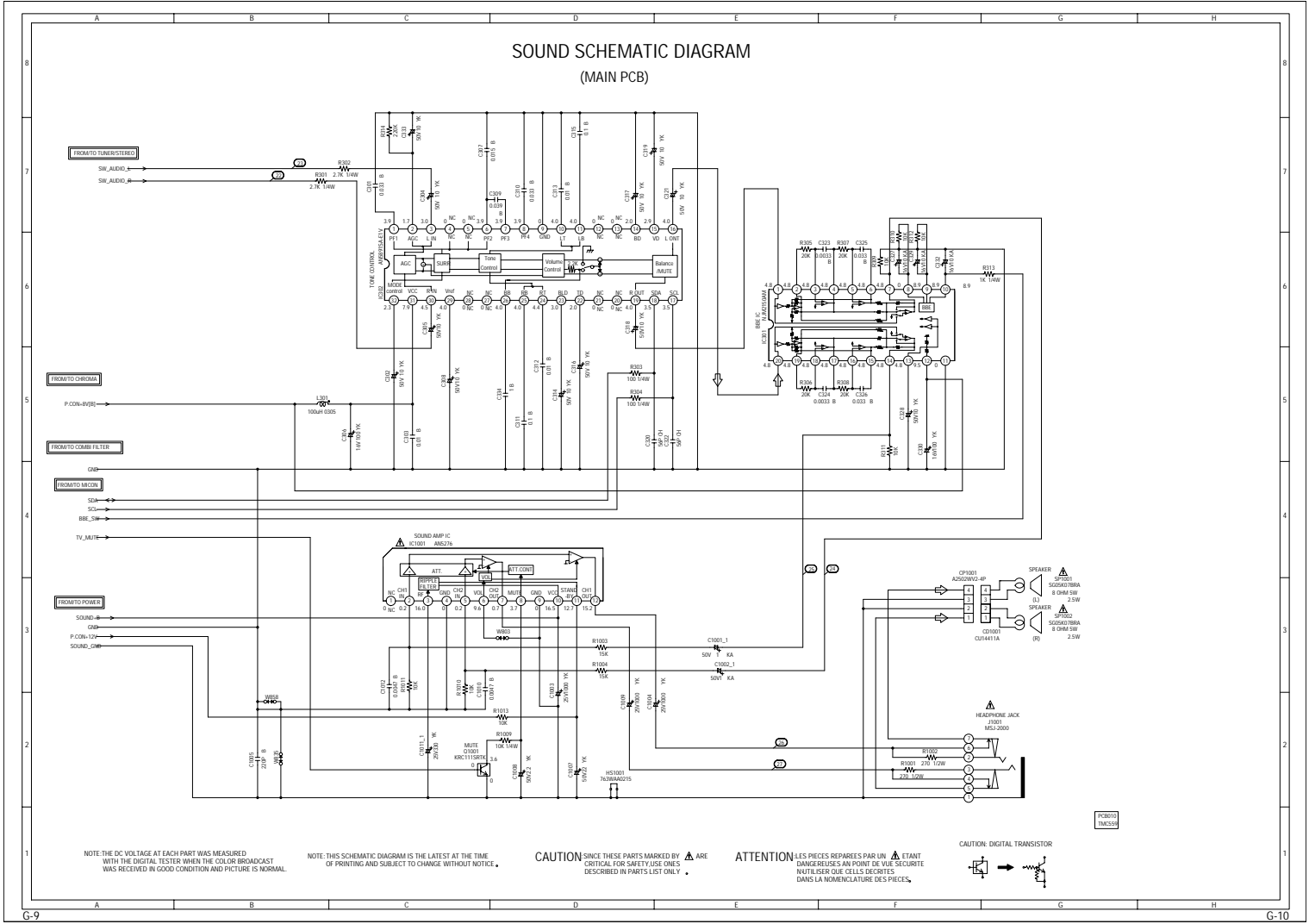

TUNER/STEREO SCHEMATIC DIAGRAM (MAIN PCB)

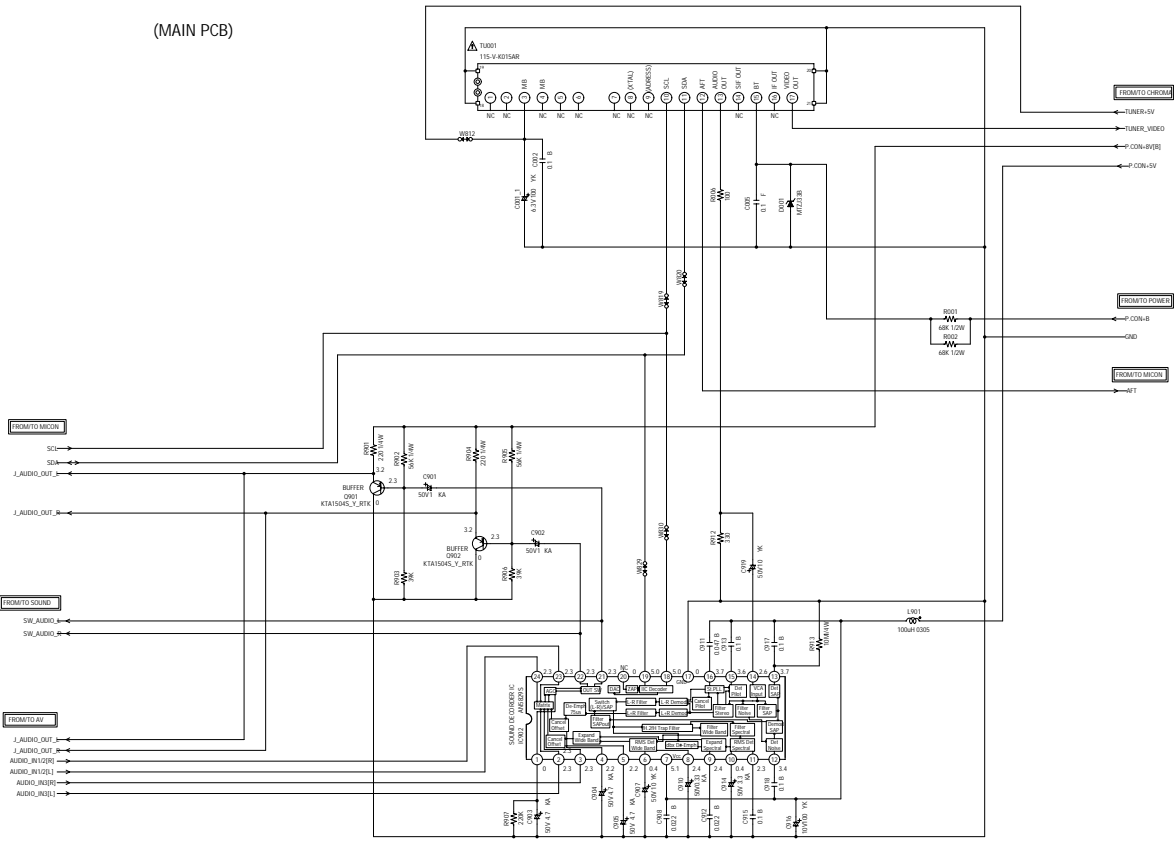

NOTE: THE DC VOLTAGE AT EACH PART WAS MEASURED WITH THE DIGITAL TESTER WHEN THE COLOR BROADCAST WAS RECEIVED IN GOOD CONDITION AND PICTURE IS NORMAL.

NOTE: THIS SCHEMATIC DIAGRAM IS THE LATEST AT THE TIME OF PRINTING AND SUBJECT TO CHANGE WITHOUT NOTICE.

CAUTION: SINCE THESE PARTS MARKED BY ARE CRITICAL FOR SAFETY, USE ONES DESCRIBED IN PARTS LIST ONLY.

ATTENTION: LES PIÈCES RÉPARÉES PAR UN ET ANT DANGEREUSES AN POINT DE VUE SECURITE. UTILISER QUE CELLES DECRIRES DANS LA NOMENCLATURE DES PIÈCES.

PORTO
TMC559

AV SCHEMATIC DIAGRAM (MAIN PCB)

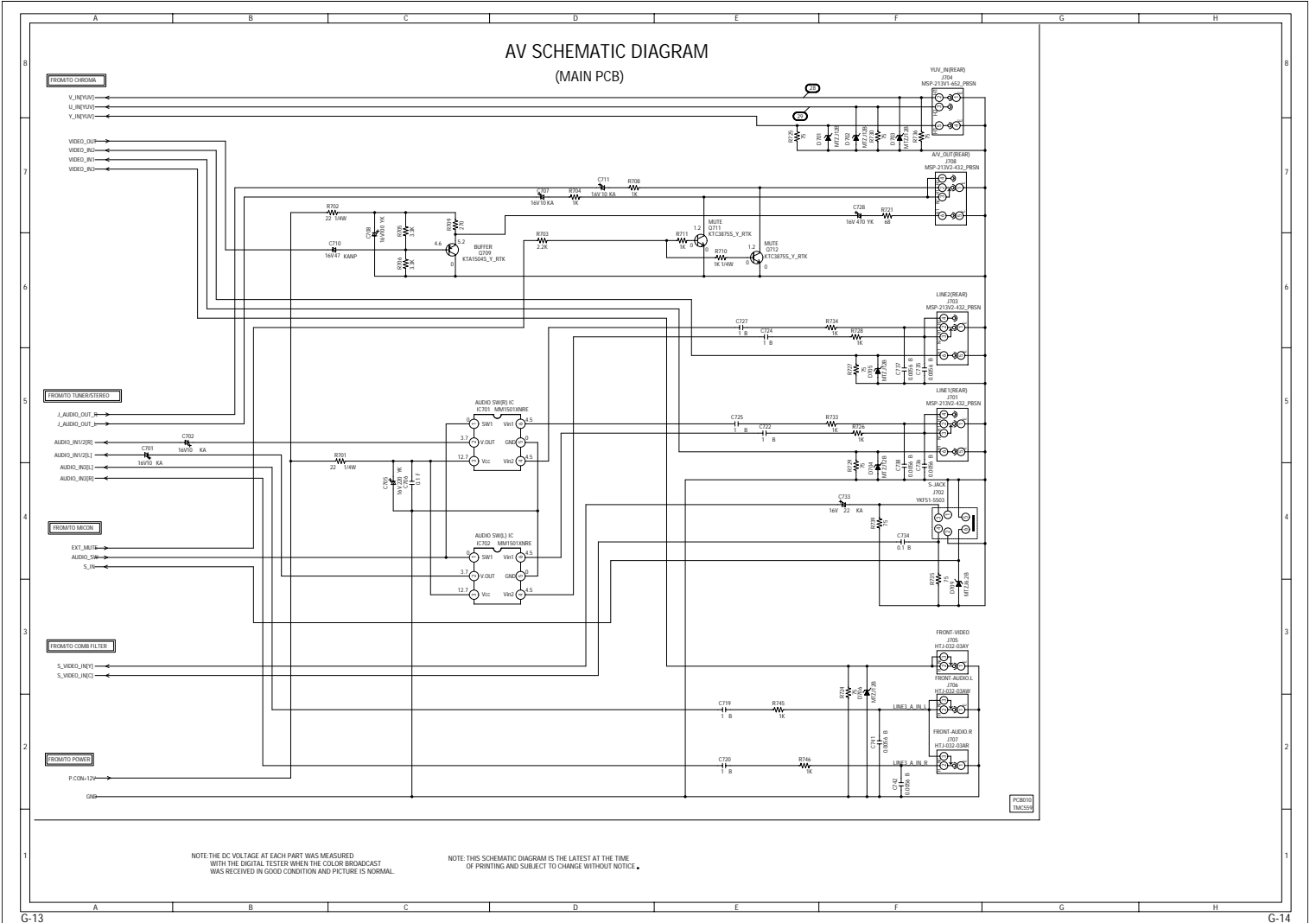

CRT/SVM SCHEMATIC DIAGRAM (CRT PCB)

CRT BLOCK

SVM BLOCK

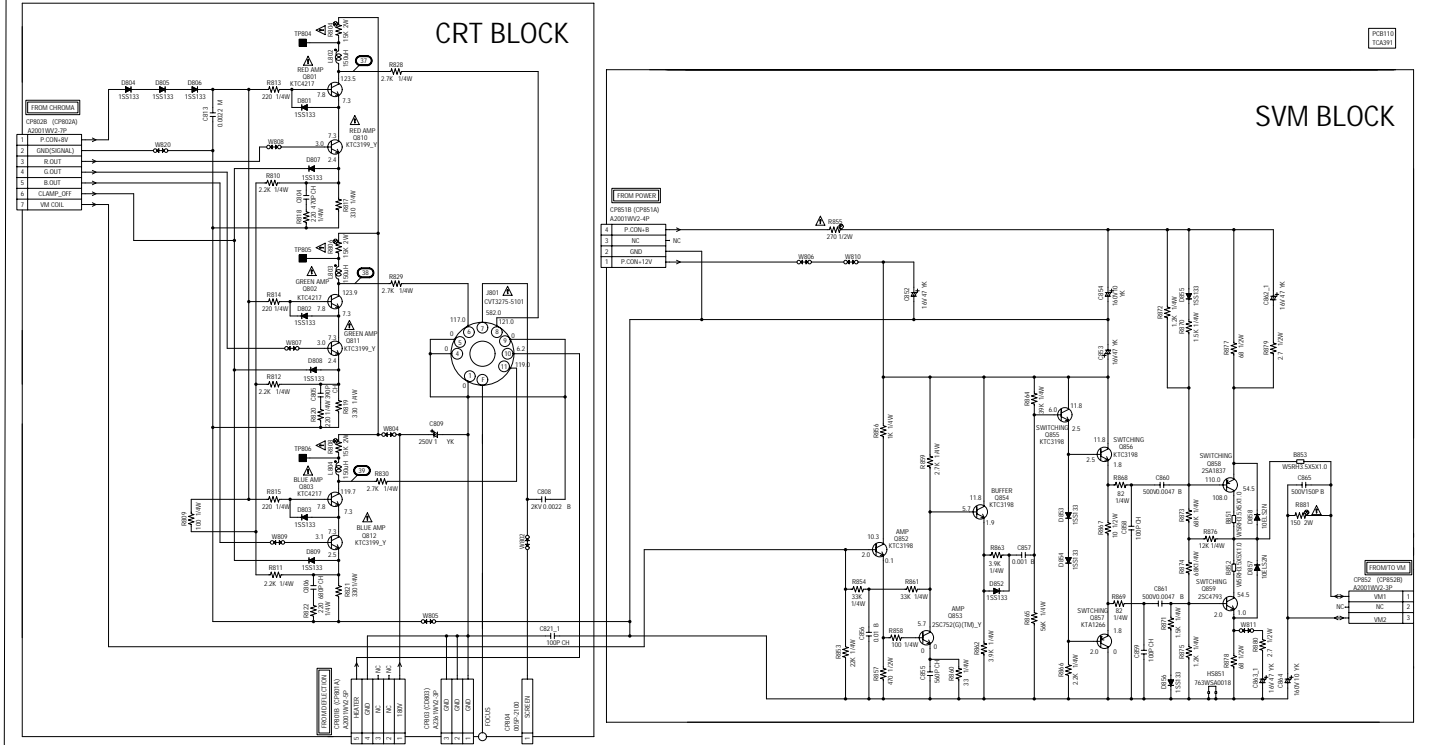

(VM COIL PCB)

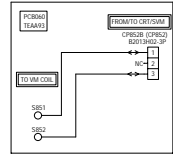

NOTE: THE DC VOLTAGE AT EACH PART WAS MEASURED WITH THE DIGITAL TESTER WHEN THE COLOR BROADCAST WAS RECEIVED IN GOOD CONDITION AND PICTURE IS NORMAL.

NOTE: THIS SCHEMATIC DIAGRAM IS THE LATEST AT THE TIME OF PRINTING AND SUBJECT TO CHANGE WITHOUT NOTICE.

CAUTION: SINCE THESE PARTS MARKED WITH Δ ARE CRITICAL FOR SAFETY, USE ONES DESCRIBED IN PARTS LIST ONLY.

ATTENTION: LES PIÈCES RÉPARÉES PAR UN Δ ÉTANT DANGEREUSES AU POINT DE VUE SÉCURITÉ, UTILISER QUE CELLES DÉCRITES DANS LA NOMÉNCLATURE DES PIÈCES.

WAVEFORMS

MICON

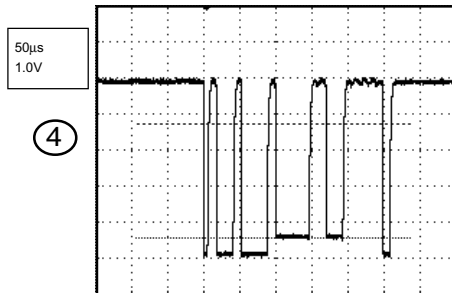
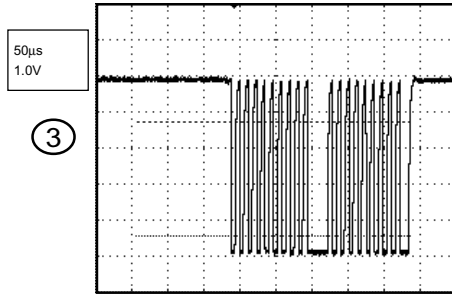
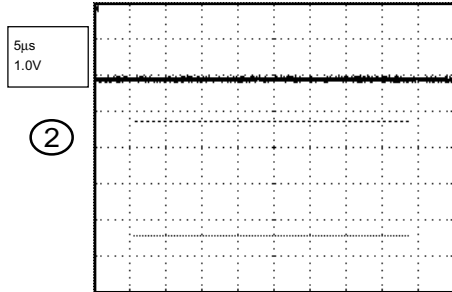
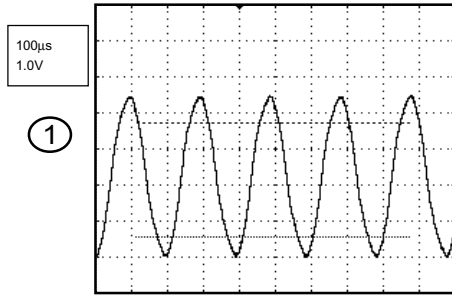

DEFRECTION

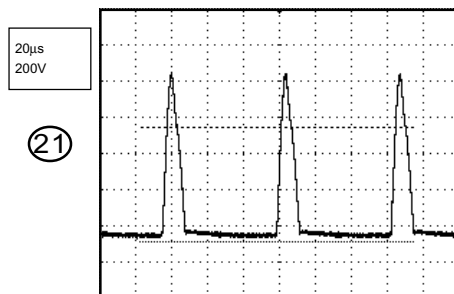
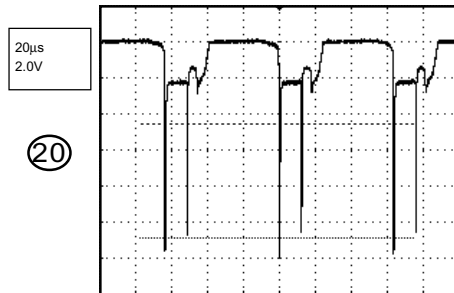
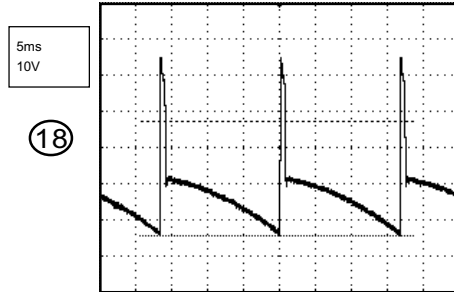
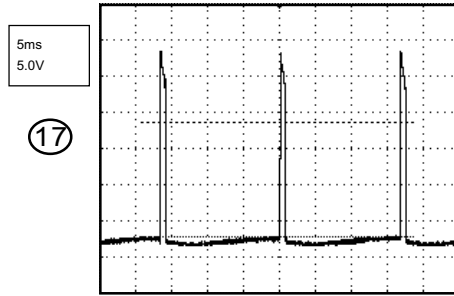
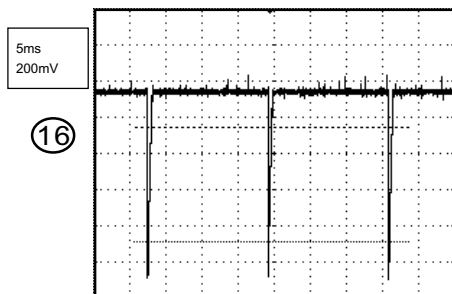

SOUND

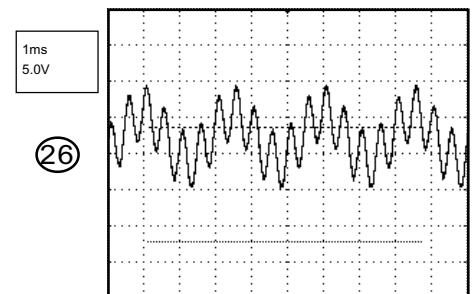
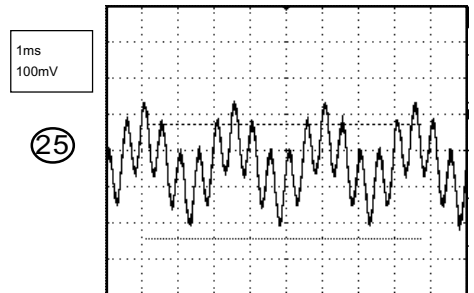
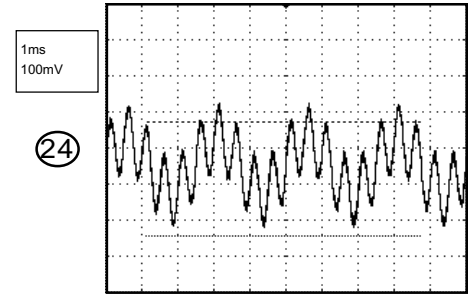
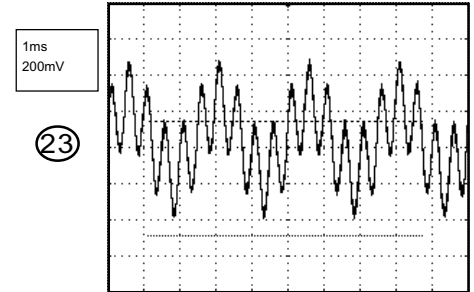
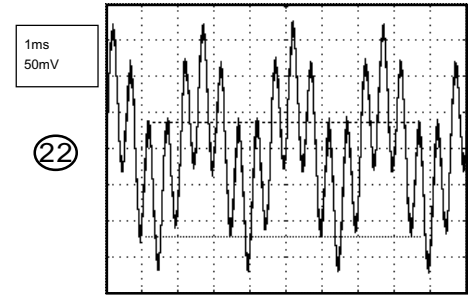

NOTE: The following waveforms were measured at the point of the corresponding balloon number in the schematic diagram.

WAVEFORMS

1ms
5.0V

27

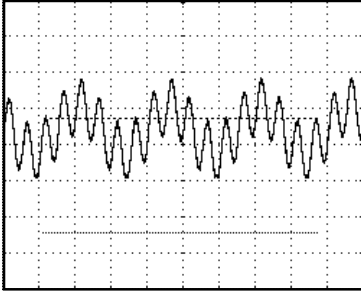

20μs
50V

39

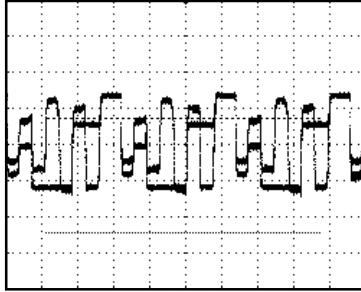

AV

20μs
200mV

28

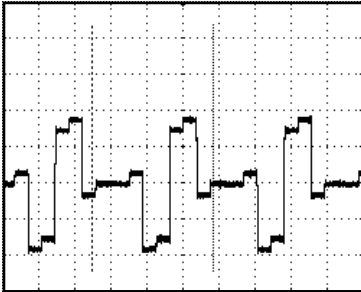

20μs
200mV

29

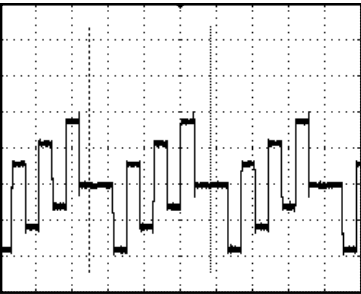

20μs
50V

37



20μs
50V

38

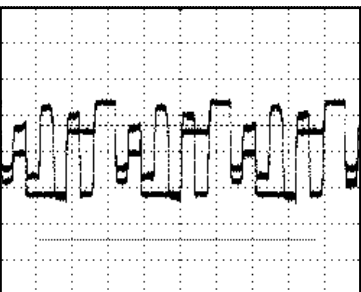

NOTE: The following waveforms were measured at the point of the corresponding balloon number in the schematic diagram.

MECHANICAL EXPLODED VIEW

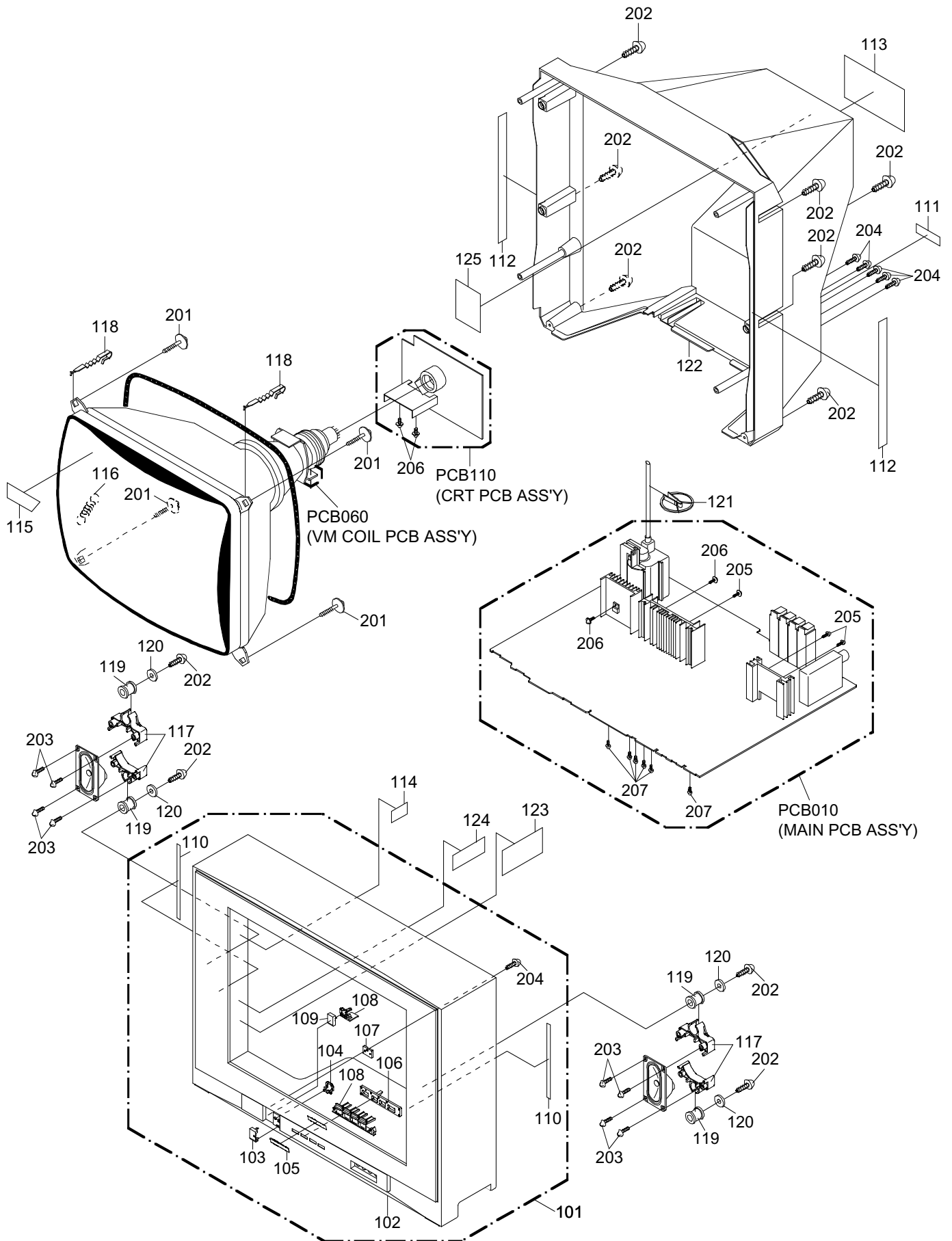

MECHANICAL REPLACEMENT PARTS LIST

Location No.	TSB P/N	Reference No.	Description	
101	AD302004	A3M701Z720	CABINET,FRONT ASSY	
102	AD302005	701WPJ1175	CABINET,FRONT	
103	AD302006	711WPA0184	PLATE,FRONT	
104	AD302007	713WPA0263	GLASS,LED	
105	AD302008	7235490036	BADGE,BRAND	
106	AD302009	735WPA0728	STOPPER,BUTTON	
107	AD302010	735WPA0732	STOPPER,BUTTON2	
108	AD302011	735WPB0243	BUTTON,FRAME	
109	AE000002	735WPJ0235	BUTTON,POWER	
110	AE000003	800WQ00045	FELT SHEET	
111	AE000004	7250000581	SHEET,PVC	
112	AD300520	800WQ00068	FELT SHEET	
113	AD302013	7225490106	SHEET,RATING	
114	AD300132	7230006818	SHEET,CAUTION	
115	AD301113	723000B873	FILM,DECORATION	
116	BZ710258	741WUA0001	SPRING,EARTH	
117	AD302015	761WPA0220	HOLDER,SPEAKER	
118	BZ710259	762WPA0011	HOLDER,CRT WIRE	
119	AD300518	801WR00001	DAMPER,SPEAKER	
120	AD300519	82A40B0104	FLAT WASHER	
121	BZ710260	899HV3T000	HOLDER,ANODE WIRE	
122	AE000005	702WPA0988	CABINET,BACK	
123	AE000006	7220001119	SHEET,CSA WARNING	
124	AE000007	7220001107	SHEET,HWC	
125	AE000008	7260000345	SHEET,SERVICEMAN	
201	AD302054	8141J50C54	SCREW,TAP TITE(P) GW22	5x35
202	BZ710035	8117540A64	SCREW,TAPPING(B0) TRUSS	4x16
203	BZ710034	8117140A24	SCREW,TAPPING(B0) PAN	4x12
204	BZ710031	8110630A04	SCREW,TAP TITE(P) BRAZIER	3x10
205	BZ710018	8107630804	SCREW,TAP TITE(S) BRAZIER	3x8
206	BZ710239	8109I30A04	SCREW,TAP TITE(B) WH7	3x10
207	BZ710019	8109630802	SCREW,TAP TITE(B) BRAZIER	3x8
---	AE000009	7230007664	SHEET,BAR CODE	
---	AE000010	791WHA0085	LAMIFILM,BAG	
---	AD302017	792WHA0432	PACKAGE, TOP	
---	AD302018	792WHA0433	PACKAGE,BOTTOM	
---	AD302019	793WCD1469	GIFT BOX	
---	AE000011	7230007398	SECURITY TAG (FOR CANADA ONLY)	
---	AD302020	A3M701Z975	INSTRUCTION BOOK KIT	
---	AD300022	J3I70417	REGISTRATION CARD	
---	AD300023	J3I70436	ESP CARD	
---	AD302021	J3M70101A	INSTRUCTION BOOK	
---	AD301213	JA4UD300	POLYBAG,INSTRUCTION(REDAUTION)	

ELECTRICAL REPLACEMENT PARTS LIST

Location No.	TSB P/N	Reference No.	Description
		RESISTORS	
R151	BZ210235	R00204103J	RC
△R402	BZ210021	R65582680J	R,FUSE
△R410	AD301344	R3X18A151J	R,METAL OXIDE
△R416	AD301593	R002T23R3J	RC
△R420	AD301345	R002T22R7J	RC
△R426	BZ210030	R4X5T4472F	R,METAL
R434	AD301972	R5X2CF5R6J	R,CEMENT
△R436	BZ210023	R4X5T4183F	R,METAL
△R438	BZ210104	R6558A2R7J	R,FUSE
R439	BZ210003	R3K181102J	R'METAL
△R441	AD300037	R4X5T6153F	R,METAL
△R452	BZ210217	R3X181331J	R,METAL OXIDE
△R500	BZ210080	R0G3K2275K	RC
△R501	AD301596	R5X2AE010J	R,CEMENT
△R502	AD301016	R3X28A331J	R,METAL OXIDE
△R506	BZ210162	R002T4682J	RC
△R517	AD301973	R3X28BR22J	R,METAL
△R520	BZ210206	R002T2155J	RC
△R527	BZ210149	R3X18AR68J	R,METAL OXIDE
R538	BZ210235	R00204103J	RC
△R541	BZ210190	R63581R22J	R,FUSE
△R542	AD301017	R3X181R15J	R,METAL OXIDE
△R602	AD301975	R3X28B120J	R,METAL OXIDE
R649	AD301975	R3X28B120J	R,METAL OXIDE
R655	BZ210235	R00204103J	RC
R657	AD301200	R00204102J	RC
△R804	BZ210026	R3X18A153J	R,METAL OXIDE
△R806	BZ210026	R3X18A153J	R,METAL OXIDE
△R808	BZ210026	R3X18A153J	R,METAL OXIDE
△R855	AD301976	R65582271J	R,FUSE
△R881	AD301344	R3X18A151J	R,METAL OXIDE
		CAPACITORS	
C408	BZ110032	E5EZF3102M	CE
△C413	AD301977	E0ELF4102M	CE
C418	BZ110136	P4J7F3394J	CMPP
△C420	AD301978	P4N8FJ133H	CMPP
C425	BZ110182	C03L0R713K	CC
△C426	AD300061	E5EZF0220M	CE
△C430	BZ110195	E02LU8220M	CE
△C501	BZ110053	E02LF3102M	CE
△C502	BZ110182	C03L0R713K	CC
△C503	BZ110182	C03L0R713K	CC
△C504	AD301729	E02LU52R2M	CE
△C505	BZ110025	P2122B224M	CMP
	BZ110138	P2472B224M	CMP
△C506	BZ110035	P2122B104M	CMP
	BZ110145	P2472B104M	CMP
△C507	BZ110012	E51CGC471M	CE
△C508	AD301108	CD39E0MH3M	CC
△C513	AD301026	CD39E0M13M	CC
C517	BZ110191	C03L0R7E3K	CC
△C519	AD301026	CD39E0M13M	CC
△C521	AD301025	E62NFB221M	CE
△C527	BZ110119	E02LF2222M	CE
C535	BZ110182	C03L0R713K	CC
C550	BZ110250	E02L02102M	CE
	AD300925	E02LT2102M	CE
C808	BZ110226	C0JBB07H3K	CC
C1003	BZ110053	E02LF3102M	CE
C1004	BZ110053	E02LF3102M	CE
C1009	BZ110053	E02LF3102M	CE
		DIODES	
D001	BZ410037	D97U03301B	DIODE,ZENER
D104	BZ410006	D1VT001330	DIODE,SILICON
D105	BZ410006	D1VT001330	DIODE,SILICON
D106	BZ410020	D97U05R11B	DIODE,ZENER
D107	BZ410006	D1VT001330	DIODE,SILICON
D108	BZ410006	D1VT001330	DIODE,SILICON
D109	BZ410054	0021721150	LED
D110	BZ410006	D1VT001330	DIODE,SILICON
D116	AE000001	D97005R61B	DIODE,ZENER

ELECTRICAL REPLACEMENT PARTS LIST

Location No.	TSB P/N	Reference No.	Description
DIODES			
D402	BZ410043	D2WT011E10	DIODE,SILICON
D403	BZ410019	D97U03001B	DIODE,ZENER
D404	BZ410020	D97U05R11B	DIODE,ZENER
△D405	BZ410063	D2WTAU02A0	DIODE,SILICON
△D406	BZ410021	D97U05R61B	DIODE,ZENER
△D407	AD301979	D2W0AU02A0	DIODE,SILICON
D410	BZ410019	D97U03001B	DIODE,ZENER
△D411	BZ410063	D2WTAU02A0	DIODE,SILICON
D414	BZ410043	D2WT011E10	DIODE,SILICON
D415	BZ410043	D2WT011E10	DIODE,SILICON
△D501	BZ410062	D2WTRM11C0	DIODE,SILICON
△D502	BZ410062	D2WTRM11C0	DIODE,SILICON
△D503	BZ410062	D2WTRM11C0	DIODE,SILICON
△D504	BZ410062	D2WTRM11C0	DIODE,SILICON
△D505	AD300076	D28F30DF60	DIODE,RECTIFIER
△D506	AD300731	D2WXN49370	DIODE,SILICON
D507	BZ410006	D1VT001330	DIODE,SILICON
D508	BZ410064	D97U03R91B	DIODE,ZENER
D509	AD300671	D97U01801B	DIODE,ZENER
△D510	AD301980	D2CF2016L0	DIODE,SILICON
△D511	AD300731	D2WXN49370	DIODE,SILICON
△D512	BZ410010	D28T21DQ9N	DIODE,SCHOTTKY
D513	BZ410006	D1VT001330	DIODE,SILICON
D514	BZ410006	D1VT001330	DIODE,SILICON
D516	BZ410006	D1VT001330	DIODE,SILICON
D517	BZ410006	D1VT001330	DIODE,SILICON
D520	BZ410006	D1VT001330	DIODE,SILICON
△D523	AD300671	D97U01801B	DIODE,ZENER
D524	BZ410006	D1VT001330	DIODE,SILICON
D525	AD300070	D97U01201B	DIODE,ZENER
D528	BZ410021	D97U05R61B	DIODE,ZENER
D601	BZ410006	D1VT001330	DIODE,SILICON
D602	BZ410058	D97U08R21B	DIODE,ZENER
D603	AD300670	D97U01501B	DIODE,ZENER
D604	AD300070	D97U01201B	DIODE,ZENER
D605	BZ410006	D1VT001330	DIODE,SILICON
D606	BZ410006	D1VT001330	DIODE,SILICON
D607	BZ410006	D1VT001330	DIODE,SILICON
D608	BZ410043	D2WT011E10	DIODE,SILICON
D610	BZ410099	D2W0B290S0	DIODE,SILICON
D611	BZ410099	D2W0B290S0	DIODE,SILICON
D701	AD300070	D97U01201B	DIODE,ZENER
D702	AD300070	D97U01201B	DIODE,ZENER
D703	AD300070	D97U01201B	DIODE,ZENER
D704	AD300070	D97U01201B	DIODE,ZENER
D705	AD300070	D97U01201B	DIODE,ZENER
D706	AD300070	D97U01201B	DIODE,ZENER
D709	BZ410066	D97U06R21B	DIODE,ZENER
D801	BZ410006	D1VT001330	DIODE,SILICON
D802	BZ410006	D1VT001330	DIODE,SILICON
D803	BZ410006	D1VT001330	DIODE,SILICON
D804	BZ410006	D1VT001330	DIODE,SILICON
D805	BZ410006	D1VT001330	DIODE,SILICON
D806	BZ410006	D1VT001330	DIODE,SILICON
D807	BZ410006	D1VT001330	DIODE,SILICON
D808	BZ410006	D1VT001330	DIODE,SILICON
D809	BZ410006	D1VT001330	DIODE,SILICON
D852	BZ410006	D1VT001330	DIODE,SILICON
D853	BZ410006	D1VT001330	DIODE,SILICON
D854	BZ410006	D1VT001330	DIODE,SILICON
D855	BZ410006	D1VT001330	DIODE,SILICON
D856	BZ410006	D1VT001330	DIODE,SILICON
D857	BZ410011	D28TELS2N2	DIODE,RECTIFIER
D858	BZ410011	D28TELS2N2	DIODE,RECTIFIER
ICS			
IC101	AD301981	I56F07090A	IC
IC199	AD301982	A3M701Z015	IC
IC301	AD300055	I0QF021500	IC
IC302	AD301983	I01FF58910	IC
△IC401	BZ611025	I03TD80400	IC
△IC504	BZ410088	0002E00610	PHOTO COUPLER
			11E1-EIC
			MTZJ30B T-77
			MTZJ5.1B T-77
			AU02A-EIC
			MTZJ5.6B T-77
			AU02A-B-EIC
			MTZJ30B T-77
			AU02A-EIC
			11E1-EIC
			11E1-EIC
			RM11C-EIC
			RM11C-EIC
			RM11C-EIC
			RM11C-EIC
			30DF6-FC
			1N4937
			1SS133T-77
			MTZJ3.9B T-77
			MTZJ18B T-77
			FE201-6L49
			1N4937
			21DQ09N-TA2B1
			1SS133T-77
			1SS133T-77
			1SS133T-77
			1SS133T-77
			1SS133T-77
			1SS133T-77
			MTZJ18B T-77
			1SS133T-77
			MTZJ12B T-77
			MTZJ5.6B T-77
			1SS133T-77
			MTZJ8.2B T-77
			MTZJ15B T-77
			MTZJ12B T-77
			1SS133T-77
			1SS133T-77
			1SS133T-77
			11E1-EIC
			SB290S-B-EIC
			SB290S-B-EIC
			MTZJ12B T-77
			MTZJ12B T-77
			MTZJ12B T-77
			MTZJ12B T-77
			MTZJ12B T-77
			MTZJ6.2B T-77
			1SS133T-77
			1SS133T-77
			1SS133T-77
			1SS133T-77
			1SS133T-77
			1SS133T-77
			1SS133T-77
			1SS133T-77
			10ELS2N-TA1B2
			10ELS2N-TA1B2
			OEC7090A
			S-24C16AFJA-TB-01
			NJM2150AM
			AN5891SA-E1V
			LA78040
			LTV-817M-VB

ELECTRICAL REPLACEMENT PARTS LIST

Location No.	TSB P/N	Reference No.	ICS	Description
IC601	AD301984	I06FC12830	IC	M61283FP
IC701	AD301988	I0UF015010	IC	MM1501XNRE
IC702	AD301988	I0UF015010	IC	MM1501XNRE
IC902	AD300059	I01FF58290	IC	AN5829S
△IC1001	AD300056	I0FSP52760	IC	AN5276
IC1501	AD301029	I03FE76600	IC	LA76600M-TLM
IC1502	AD301988	I0UF015010	IC	MM1501XNRE
IC1503	AD301988	I0UF015010	IC	MM1501XNRE
TRANSISTORS				
Q101	BZ510109	TCAA3875SY	TRANSISTOR,SILICON	KTC3875S_Y_RTK
Q103	BZ510109	TCAA3875SY	TRANSISTOR,SILICON	KTC3875S_Y_RTK
△Q402	BZ510097	TCAT03227Y	TRANSISTOR,SILICON	KTC3227_Y-AT
△Q405	BZ510040	TDUU024990	TRANSISTOR,SILICON	2SD2499(LB0EC1)
△Q502	BZ510098	T220033260	FET	2SK3326(2)
△Q503	BZ510005	TA3T1371A0	TRANSISTOR,SILICON	2SA1371(D,E)-AE
Q504	BZ510069	TCATC31980	TRANSISTOR,SILICON	KTC3198-AT(Y,GR)
△Q505	BZ510011	TC3T029090	TRANSISTOR,SILICON	2SC2909(S,T)-AA
△Q507	BZ510069	TCATC31980	TRANSISTOR,SILICON	KTC3198-AT(Y,GR)
△Q508	BZ510077	TAAT012714	TRANSISTOR,SILICON	KTA1271_Y-AT
Q509	BZ510069	TCATC31980	TRANSISTOR,SILICON	KTC3198-AT(Y,GR)
△Q512	BZ510004	TA3T016240	TRANSISTOR,SILICON	2SA1624-AA
△Q514	BZ510070	TCAT032034	TRANSISTOR,SILICON	KTC3203_Y-AT
Q601	BZ510105	TCAT03209Y	TRANSISTOR,SILICON	KTC3209_Y-AT
Q602	BZ510105	TCAT03209Y	TRANSISTOR,SILICON	KTC3209_Y-AT
Q603	BZ510109	TCAA3875SY	TRANSISTOR,SILICON	KTC3875S_Y_RTK
Q604	BZ510105	TCAT03209Y	TRANSISTOR,SILICON	KTC3209_Y-AT
Q605	BZ510109	TCAA3875SY	TRANSISTOR,SILICON	KTC3875S_Y_RTK
Q606	BZ510105	TCAT03209Y	TRANSISTOR,SILICON	KTC3209_Y-AT
Q607	BZ510070	TCAT032034	TRANSISTOR,SILICON	KTC3203_Y-AT
Q610	BZ510109	TCAA3875SY	TRANSISTOR,SILICON	KTC3875S_Y_RTK
Q611	BZ510105	TCAT03209Y	TRANSISTOR,SILICON	KTC3209_Y-AT
Q613	BZ510109	TCAA3875SY	TRANSISTOR,SILICON	KTC3875S_Y_RTK
Q614	BZ510108	TAAA1504SY	TRANSISTOR,SILICON	KTA1504S_Y_RTK
Q709	BZ510108	TAAA1504SY	TRANSISTOR,SILICON	KTA1504S_Y_RTK
Q711	BZ510109	TCAA3875SY	TRANSISTOR,SILICON	KTC3875S_Y_RTK
Q712	BZ510109	TCAA3875SY	TRANSISTOR,SILICON	KTC3875S_Y_RTK
△Q801	BZ510091	TCA0042170	TRANSISTOR,SILICON	KTC4217(O,Y)
△Q802	BZ510091	TCA0042170	TRANSISTOR,SILICON	KTC4217(O,Y)
△Q803	BZ510091	TCA0042170	TRANSISTOR,SILICON	KTC4217(O,Y)
△Q810	AD301032	TCATC3199Y	TRANSISTOR,SILICON	KTC3199_Y-AT
△Q811	AD301032	TCATC3199Y	TRANSISTOR,SILICON	KTC3199_Y-AT
△Q812	AD301032	TCATC3199Y	TRANSISTOR,SILICON	KTC3199_Y-AT
Q852	BZ510069	TCATC31980	TRANSISTOR,SILICON	KTC3198-AT(Y,GR)
Q853	AD300024	TCUT00752Y	TRANSISTOR,SILICON	2SC752(G)(TM)_Y
Q854	BZ510069	TCATC31980	TRANSISTOR,SILICON	KTC3198-AT(Y,GR)
Q855	BZ510069	TCATC31980	TRANSISTOR,SILICON	KTC3198-AT(Y,GR)
Q856	BZ510069	TCATC31980	TRANSISTOR,SILICON	KTC3198-AT(Y,GR)
Q857	BZ510073	TAATA12660	TRANSISTOR,SILICON	KTA1266-AT(Y,GR)
Q858	AD300029	TAU0018370	TRANSISTOR,SILICON	2SA1837
Q859	AD300025	TCU0047930	TRANSISTOR,SILICON	2SC4793
Q901	BZ510108	TAAA1504SY	TRANSISTOR,SILICON	KTA1504S_Y_RTK
Q902	BZ510108	TAAA1504SY	TRANSISTOR,SILICON	KTA1504S_Y_RTK
Q1001	BZ510068	TNAAJ05003	COMPOUND TRANSISTOR	KRC111SRTK
Q1503	BZ510109	TCAA3875SY	TRANSISTOR,SILICON	KTC3875S_Y_RTK
Q1504	BZ510109	TCAA3875SY	TRANSISTOR,SILICON	KTC3875S_Y_RTK
Q1507	BZ510109	TCAA3875SY	TRANSISTOR,SILICON	KTC3875S_Y_RTK
Q1508	BZ510109	TCAA3875SY	TRANSISTOR,SILICON	KTC3875S_Y_RTK
COILS & TRANSFORMERS				
L301	BZ310041	02167F101J	COIL	100 UH
L401	BZ310004	021679472K	COIL	4.7 MH
L402	BZ310063	022100027A	COIL,LINEARITY	ELH5L4113
△L501	AD300119	029T000097	COIL,LINE FILTER	1R5A123F28Y
△L503	BZ310066	028R200024	COIL,DEGAUSS	8R200024
L601	AD301989	0216A6330J	COIL	33 UH
	AD301990	021LA6330J	COIL	33 UH
L802	AD300123	021673151K	COIL	150 UH
L803	AD300123	021673151K	COIL	150 UH
L804	AD300123	021673151K	COIL	150 UH
L901	BZ310041	02167F101J	COIL	100 UH
L1501	BZ310041	02167F101J	COIL	100 UH
L1502	AD301417	02167F221J	COIL	220 UH

or

ELECTRICAL REPLACEMENT PARTS LIST

Location No.	TSB P/N	Reference No.	Description	
COILS & TRANSFORMERS				
L1503	AD301417	02167F221J	COIL	220 UH
L1505	AD300613	02167F150J	COIL	15 UH
L1508	BZ310041	02167F101J	COIL	100 UH
L1510	AD300613	02167F150J	COIL	15 UH
L1511	AD300613	02167F150J	COIL	15 UH
L1512	AD301608	0216A6220J	COIL	22 UH
	AD301033	021LA6220J	COIL LAP02TA220J	22 UH
T401	BZ310172	045013003J	TRANS,HORIZONTAL DRIVE	ETH14Y47AY
△T501	AD301034	048140066S	TRANSFORMER,SWITCHING	8140066S
JACKS				
J701	AD301038	060J431019	RCA JACK	MSP-213V2-432 PBSN
J702	AD300108	063Q700002	JACK	YKF51-5503
J703	AD301038	060J431019	RCA JACK	MSP-213V2-432 PBSN
J704	AD301037	060J411024	RCA JACK	MSP-213V1-652 PBSN
J705	AD300110	060G401047	RCA JACK	HTJ-032-03AY
J706	AD300111	060G401046	RCA JACK	HTJ-032-03AW
J707	AD300112	060G401039	RCA JACK	HTJ-032-03AR
J708	AD301038	060J431019	RCA JACK	MSP-213V2-432 PBSN
△J801	BZ614115	066C130017	SOCKET,CATHODE RAY TUBE	CVT3275-5101
△J1001	BZ614361	060J131015	HEADPHONE JACK	MSJ-2000
SWITCHES				
SW101	BZ612010	0504101T34	SWITCH,TACT	EVQ21505R
	BZ612001	0504201T31	SWITCH,TACT	SKHVBED010
SW102	BZ612010	0504101T34	SWITCH,TACT	EVQ21505R
	BZ612001	0504201T31	SWITCH,TACT	SKHVBED010
SW103	BZ612010	0504101T34	SWITCH,TACT	EVQ21505R
	BZ612001	0504201T31	SWITCH,TACT	SKHVBED010
SW104	BZ612010	0504101T34	SWITCH,TACT	EVQ21505R
	BZ612001	0504201T31	SWITCH,TACT	SKHVBED010
SW105	BZ612010	0504101T34	SWITCH,TACT	EVQ21505R
	BZ612001	0504201T31	SWITCH,TACT	SKHVBED010
VARIABLE RESISTORS				
VR401	BZ210108	V116313BTC	VOLUME,SEMI FIXED	EVNVCYAA03B13
VR502	BZ210101	V1163H4BTC	VOLUME,SEMI FIXED	EVNVCYAA03BE4
P.C. BOARD ASSEMBLIES				
PCB010	AD301991	A3M701Z010	PCB ASS'Y	TMC559A
PCB060	AD301992	A3M701Z060	PCB ASS'Y	TEAA93B
PCB110	AD301993	A3M701Z110	PCB ASS'Y	TCA391B
MISCELLANEOUS				
B401	BZ310129	024HT03564	CORE,BEADS	W4BRH3.5X6X1.0
B402	BZ310129	024HT03564	CORE,BEADS	W4BRH3.5X6X1.0
B403	BZ310122	024HT03563	CORE,BEADS	W4BRH3.5X6X1.0X2
B405	BZ310129	024HT03564	CORE,BEADS	W4BRH3.5X6X1.0
B501	BZ310045	024AT03481	CORE,BEADS	BL02RN1-R62T2
B504	BZ310121	024HT03553	CORE,BEADS	W5RH3.5X5X1.0
B851	BZ310121	024HT03553	CORE,BEADS	W5RH3.5X5X1.0
B852	BZ310121	024HT03553	CORE,BEADS	W5RH3.5X5X1.0
B853	BZ310121	024HT03553	CORE,BEADS	W5RH3.5X5X1.0
BT001	AE000012	1412004008	BATTERY,MANGAN	R03(AB)E_2P_G
BT002	AE000012	1412004008	BATTERY,MANGAN	R03(AB)E_2P_G
△CD501	AD300746	120R615901	CORD,AC BUSH	0R615901
CD801	AD301042	06CU253401	CORD,CONNECTOR	CU253401
CD802	AD301994	06CU274201	CORD,CONNECTOR	CU274201
CD803	AD300094	06CP83035A	CORD,CONNECTOR	CP83035A
CD851	AD301995	06CU244201	CORD,CONNECTOR	CU244201
CD852	AD301043	06CU232001	CORD,CONNECTOR	CU232001
CP101	BZ614102	0694270139	CONNECTOR PCB SIDE	173979-7
△CP401	AD300095	069X460029	CONNECTOR PCB SIDE	B06B-DVS
△CP501	BZ614176	069S320419	CONNECTOR PCB SIDE	A3963WV2-3PD
△CP502	AD300687	069S420110	CONNECTOR PCB SIDE	A1561WV2-2P
CP507	BZ614444	069D01001A	CONNECTOR PCB SIDE	003P-2100
	BZ614016	069W01001A	CONNECTOR PCB SIDE	003P-2100
CP508	BZ614444	069D01001A	CONNECTOR PCB SIDE	003P-2100
	BZ614016	069W01001A	CONNECTOR PCB SIDE	003P-2100
CP803	AD301996	069S330010	CONNECTOR PCB SIDE	A2361WV2-3P
	AD300096	069W330018	CONNECTOR PCB SIDE	TS-80P-03-V1
CP804	BZ614058	069W010010	CONNECTOR PCB SIDE	005P-2100
CP852	BZ614350	069S230629	CONNECTOR PCB SIDE	A2001WV2-3P
CD1001	AD300093	06CU14411A	CORD,CONNECTOR	CU14411A
CP1001	AD301045	069S140419	CONNECTOR PCB SIDE	A2502WV2-4P
CP801A	BZ614276	067U005049	WIRE HOLDER	B2013H02-5P

ELECTRICAL REPLACEMENT PARTS LIST

Location No.	TSB P/N	Reference No.	Description
MISCELLANEOUS			
CP801B	AD300752	069S250629	CONNECTOR PCB SIDE A2001WV2-5P
CP802A	AD301997	067U007029	WIRE HOLDER B2013H02-7P
CP802B	BZ614485	069S270629	CONNECTOR PCB SIDE A2001WV2-7P
CP851A	BZ614334	067U004029	WIRE HOLDER B2013H02-4P
CP851B	AD301998	069S240629	CONNECTOR PCB SIDE A2001WV2-4P
CP852B	BZ614349	067U003029	WIRE HOLDER B2013H02-3P
EL001	BZ614044	124120301A	EYE LET XRY20X30BD
EL002	BZ614043	124116281A	EYE LET XRY16X28BD
△F501	AD301046	081PC6R305	FUSE 51MS063L
△FB401	AD301999	043220057F	TRANSFORMER,FLYBACK FJN20A002
FH501	BZ614005	06710T0006	HOLDER,FUSE EYF-52BC
FH502	BZ614005	06710T0006	HOLDER,FUSE EYF-52BC
OS101	AD301048	0773071001	REMOTE RECEIVER RPM7138-H5
△RY501	AD300114	0560V20115	RELAY ALKS321
△SP1001	AD301050	070C457003	SPEAKER SG05K07BRA
△SP1002	AD301050	070C457003	SPEAKER SG05K07BRA
△TH501	AD302000	D8EE0B1400	DEGAUSS ELEMENT B59203-S1060-B14
TM101	AD302001	076R0GF010	TRANSMITTER R25-1911
△TU001	AD301800	0163300001	RF UNIT 115-V-K015AR
△V801	AD301053	098W210437	CRT W/DY A51LVV896X07(O)
X101	AD302002	100CT8R005	CRYSTAL HC-49/U-S
X602	AD302003	100CT3R505	CRYSTAL HC-49/C

RESISTOR

RC..... CARBON RESISTOR

CAPACITORS

CC..... CERAMIC CAPACITOR
 CE..... ALUMI ELECTROLYTIC CAPACITOR
 CP..... POLYESTER CAPACITOR
 CPP..... POLYPROPYLENE CAPACITOR
 CPL..... PLASTIC CAPACITOR
 CMP..... METAL POLYESTER CAPACITOR
 CMPL..... METAL PLASTIC CAPACITOR
 CMPP..... METAL POLYPROPYLENE CAPACITOR

TOSHIBA CORPORATION

1-1, SHIBAURA 1-CHOME, MINATO-KU, TOKYO 105-8001, JAPAN