

SERVICE MANUAL

SELF-DIAGNOSTIC FUNCTION

BA-4 CHASSIS

<i>MODEL</i>	<i>COMMANDER</i>	<i>DEST.</i>	<i>CHASSIS NO.</i>
<i>KV-27S40</i>	<i>RM-Y165</i>	<i>US</i>	<i>SCC-S01H-A</i>
<i>KV-27S40</i>	<i>RM-Y165</i>	<i>CND</i>	<i>SCC-S03E-A</i>
<i>KV-27S45</i>	<i>RM-Y167</i>	<i>US</i>	<i>SCC-S01J-A</i>
<i>KV-27S45</i>	<i>RM-Y167</i>	<i>CND</i>	<i>SCC-S03F-A</i>
<i>KV-27S65</i>	<i>RM-Y167</i>	<i>US</i>	<i>SCC-S01K-A</i>
<i>KV-27S65</i>	<i>RM-Y167</i>	<i>CND</i>	<i>SCC-S03G-A</i>
<i>KV-29SL40</i>	<i>RM-Y165</i>	<i>E</i>	<i>SCC-S04X-A</i>
<i>KV-29SL40A</i>	<i>RM-Y165</i>	<i>E</i>	<i>SCC-S04S-A</i>
<i>KV-29SL40C</i>	<i>RM-Y165</i>	<i>E</i>	<i>SCC-S04U-A</i>
<i>KV-29SL45</i>	<i>RM-Y167</i>	<i>E</i>	<i>SCC-S04Y-A</i>
<i>KV-29SL65</i>	<i>RM-Y167</i>	<i>E</i>	<i>SCC-S06F-A</i>
<i>KV-29SL65C</i>	<i>RM-Y167</i>	<i>E</i>	<i>SCC-S04V-A</i>
<i>KV-29XL40M</i>	<i>RM-Y165</i>	<i>MX</i>	<i>SCC-S02D-A</i>
<i>KV-29XL40P</i>	<i>RM-Y165</i>	<i>E</i>	<i>SCC-S04R-A</i>
<i>KV-29XT11A</i>	<i>RM-Y165</i>	<i>E</i>	<i>SCC-S04T-A</i>



KV-27S45



RM-Y167



TRINITRON® COLOR TV
SONY®

WARNINGS AND CAUTIONS

CAUTION!

SHORT CIRCUIT THE ANODE OF THE PICTURE TUBE AND THE ANODE CAP TO THE METAL CHASSIS, CRT SHIELD, OR CARBON PAINTED ON THE CRT, AFTER REMOVING THE ANODE.

WARNING!!

AN ISOLATION TRANSFORMER SHOULD BE USED DURING ANY SERVICE TO AVOID POSSIBLE SHOCK HAZARD, BECAUSE OF LIVE CHASSIS. THE CHASSIS OF THIS RECEIVER IS DIRECTLY CONNECTED TO THE AC POWER LINE.

SAFETY-RELATED COMPONENT WARNING!!

COMPONENTS IDENTIFIED BY SHADING AND MARK Δ ON THE SCHEMATIC DIAGRAMS, EXPLODED VIEWS AND IN THE PARTS LIST ARE CRITICAL FOR SAFE OPERATION. REPLACE THESE COMPONENTS WITH SONY PARTS WHOSE PART NUMBERS APPEAR AS SHOWN IN THIS MANUAL OR IN SUPPLEMENTS PUBLISHED BY SONY. CIRCUIT ADJUSTMENTS THAT ARE CRITICAL FOR SAFE OPERATION ARE IDENTIFIED IN THIS MANUAL. FOLLOW THESE PROCEDURES WHENEVER CRITICAL COMPONENTS ARE REPLACED OR IMPROPER OPERATION IS SUSPECTED.

ATTENTION

APRES AVOIR DECONNECTE LE CAP DE L'ANODE, COURT-CIRCUITER L'ANODE DU TUBE CATHODIQUE ET CELUI DE L'ANODE DU CAP AU CHASSIS METALLIQUE DE L'APPAREIL, OU AU COUCHE DE CARBONE PEINTE SUR LE TUBE CATHODIQUE OU AU BLINDAGE DU TUBE CATHODIQUE.

ATTENTION!!

AFIN D'EVITER TOUT RESQUE D'ELECTROCUTION PROVENANT D'UN CHÂSSIS SOUS TENSION, UN TRANSFORMATEUR D'ISOLEMENT DOIT ETRE UTILISÉ LORS DE TOUT DÉPANNAGE. LE CHÂSSIS DE CE RÉCEPTEUR EST DIRECTEMENT RACCORDÉ À L'ALIMENTATION SECTEUR.

ATTENTION AUX COMPOSANTS RELATIFS A LA SECURITE!!

LES COMPOSANTS IDENTIFIES PAR UNE TRAME ET PAR UNE MARQUE Δ SUR LES SCHEMAS DE PRINCIPE, LES VUES EXPLOSEES ET LES LISTES DE PIECES SONT D'UNE IMPORTANCE CRITIQUE POUR LA SECURITE DU FONCTIONNEMENT. NE LES REMPLACER QUE PAR DES COMPOSANTS SONY DONT LE NUMERO DE PIECE EST INDIQUE DANS LE PRESENT MANUEL OU DANS DES SUPPLEMENTS PUBLIES PAR SONY. LES REGLAGES DE CIRCUIT DONT L'IMPORTANCE EST CRITIQUE POUR LA SECURITE DU FONCTIONNEMENT SONT IDENTIFIES DANS LE PRESENT MANUEL. SUIVRE CES PROCEDURES LORS DE CHAQUE REMPLACEMENT DE COMPOSANTS CRITIQUES, OU LORSQU'UN MAUVAIS FONCTIONNEMENT SUSPECTE.

SELF-DIAGNOSTIC FUNCTION

The units in this manual contain a self-diagnostic function. If an error occurs, the STANDBY/TIMER lamp will automatically begin to flash. The number of times the lamp flashes translates to a probable source of the problem. A definition of the STANDBY/TIMER lamp flash indicators is listed in the instruction manual for the user's knowledge and reference. If an error symptom cannot be reproduced, the remote commander can be used to review the failure occurrence data stored in memory to reveal past problems and how often these problems occur.

1. DIAGNOSTIC TEST INDICATORS

When an error occurs, the STANDBY/TIMER lamp will flash a set number of times to indicate the possible cause of the problem. If there is more than one error, the lamp will identify the first of the problem areas.

Results for all of the following diagnostic items are displayed on screen. No error has occurred if the the screen displays a "0" .

Diagnostic Item Description	No. of times STANDBY/TIMER lamp flashes	Self-diagnostic display/ Diagnostic result	Probable Cause Location	Detected Symptoms
* Power does not turn on	Does not light	—	* Power cord is not plugged in. * Fuse is burned out (F5050) (E Board)	* Power does not come on. * No power is supplied to the TV. * AC power supply is faulty.
* +B overcurrent (OCP)	2 times	2:0 or 2:1	* H.OUT (Q502) is shorted. (A board) * IC1751 and Q1751 is shorted. (C board)	* Power does not come on. * Load on power line is shorted.
* Vertical deflection stopped	4 times	4:0 or 4:1	* +13V is not supplied. (A board) * IC 541 is faulty (A board)	* Has entered standby state after horizontal raster. * Vertical deflection pulse is stopped. * Power line is shorted or power supply is stopped.
* White balance failure (not balanced)	5 times	5:0 or 5:1	* Video OUT (Q306 to 308) is faulty. (A board) * IC301 is faulty. (A board) * G2 is improperly adjusted. (Note 2)	* No raster is generated. * CRT cathode current detection reference pulse output is small.

Note 1: If a +B overcurrent is detected, stoppage of the vertical deflection is detected simultaneously.
The symptom that is diagnosed first by the microcontroller is displayed on the screen.

Note 2: Refer to Screen (G2) Adjustment in Section 3-4 of this manual.

2. DISPLAY OF STANDBY/TIMER LIGHT FLASH COUNT

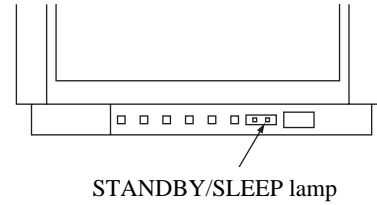
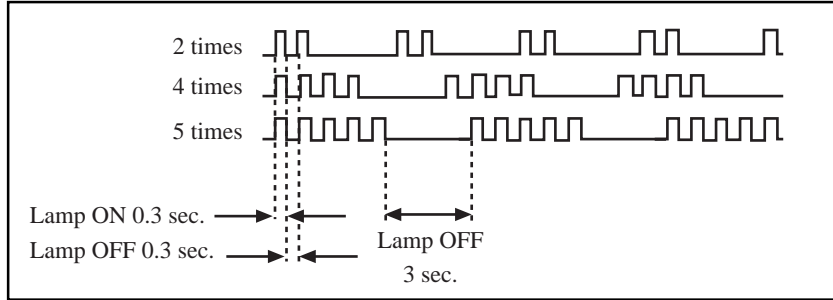

Diagnostic Item	Flash Count*
+B overcurrent	2 times
Vertical deflection stopped	4 times
White balance failure	5 times

* One flash count is not used for self-diagnostic.

3. STOPPING THE STANDBY/TIMER FLASH

Turn off the power switch on the TV main unit or unplug the power cord from the outlet to stop the STANDBY/TIMER lamp from flashing.

4. SELF-DIAGNOSTIC SCREEN DISPLAY

For errors with symptoms such as "power sometimes shuts off" or "screen sometimes goes out" that cannot be confirmed, it is possible to bring up past occurrences of failure for confirmation on the screen:

[To Bring Up Screen Test]

In standby mode, press buttons on the remote commander sequentially in rapid succession as shown below:

Screen display → channel [5] → Sound volume [−] → Power ON
↑

Note that this differs from entering the service mode (sound volume [+]).

Self-Diagnostic screen display

SELF DIAGNOSTIC		
2:		0
3:	N/A	0
4:		0
5:		1
101:	N/A	0

-----Numeral "0" means that no fault has been detected.

-----Numeral "1" means a fault has been detected one time only.

5. HANDLING OF SELF-DIAGNOSTIC SCREEN DISPLAY

Since the diagnostic results displayed on the screen are not automatically cleared, always check the self-diagnostic screen during repairs. When you have completed the repairs, clear the result display to "0".

Unless the result display is cleared to "0", the self-diagnostic function will not be able to detect subsequent faults after completion of the repairs.

[Clearing the result display]

To clear the result display to "0", press buttons on the remote commander sequentially as shown below when the diagnostic screen is being displayed.

Channel [8] → [ENTER]

[Quitting Self-diagnostic screen]

To quit the entire self-diagnostic screen, turn off the power switch on the remote commander or the main unit.

6. SELF-DIAGNOSTIC CIRCUIT

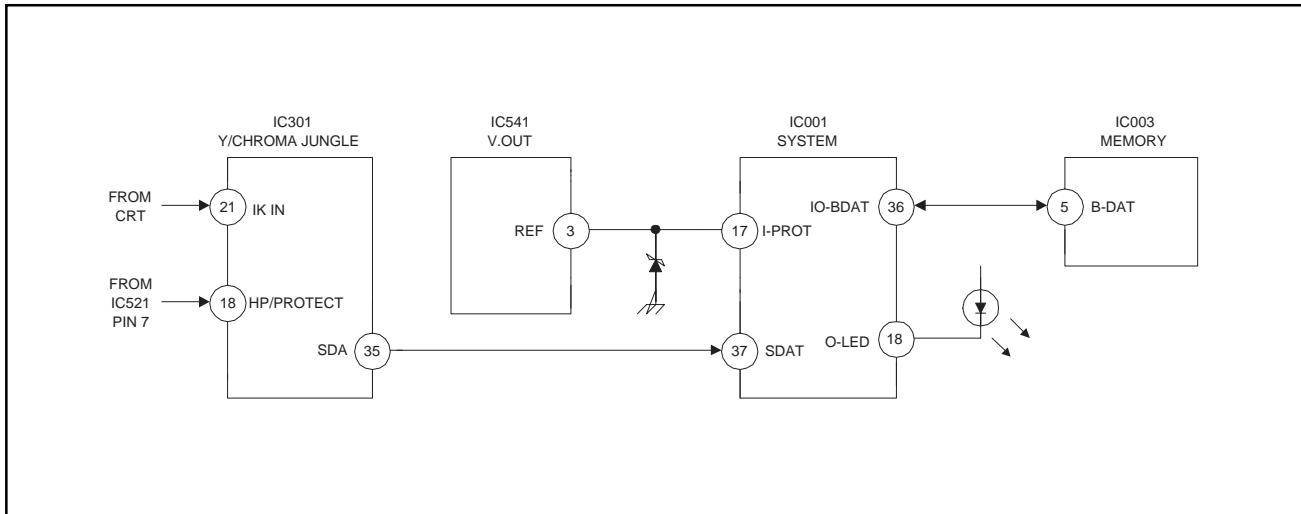

+B overcurrent (OCP)

Occurs when an overcurrent on the +B(115V) line is detected by pin 18 of IC301. If the voltage to pin 18 of IC301 is less than 1V when V.SYNC is more than seven verticals in a period, the unit will automatically turn off.

Vertical deflection stopped

Occurs when an absence of the vertical deflection pulse is detected by pin 17 of IC001. Power supply will shut down when waveform interval exceeds 2 seconds.

White balance failure

If the RGB levels* do not balance within 2 seconds after the power is turned on, this error will be detected by IC301. TV will stay on, but there will be no picture.

*(Refers to the RGB levels of the AKB detection Ref pulse that detects IK.)

SECTION 3 SET-UP ADJUSTMENTS

The following adjustments should be made when a complete realignment is required or a new picture tube is installed. These adjustments should be performed with rated power supply voltage unless otherwise noted.

The controls and switch should be set as follows unless otherwise noted:

PICTURE control normal

BRIGHTNESS control normal

Perform the adjustments in order as follows:

1. Beam Landing
2. Convergence
3. Focus
4. Screen (G2) and White Balance

Note: Test Equipment Required

1. Color Bar Pattern Generator
2. Degausser
3. DC Power Supply
4. Digital Multimeter

3-1. BEAM LANDING

Preparation:

- Feed in the white pattern signal.
- Before starting, degauss the entire screen.

1. Input a raster signal with the pattern generator.
2. Loosen the deflection yoke mounting screw, and set the purity control to the center as shown in Fig.2.
3. Turn the raster signal of the pattern generator to green.
4. Move the deflection yoke backward, and adjust with the purity control so that green is in the center and red and blue are at the sides evenly. (Fig.3)
5. Move the deflection yoke forward, and adjust so that the entire screen becomes green. (Fig.1)
6. Switch over the raster signal to red and blue and confirm the condition.
7. When the position of the deflection yoke is determined, tighten it with the deflection yoke mounting screw.
8. When landing at the corner is not right, adjust by using the disk magnets. (Fig.4)

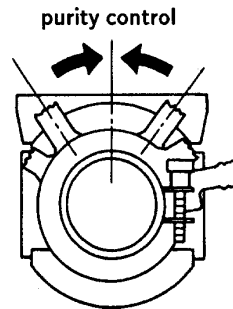

Fig. 2

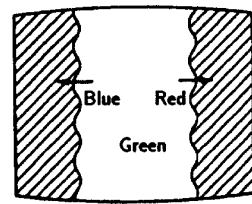

Fig. 3

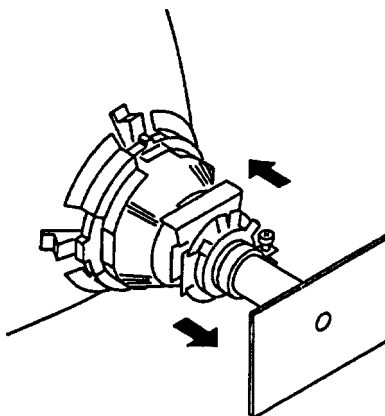

Fig. 1

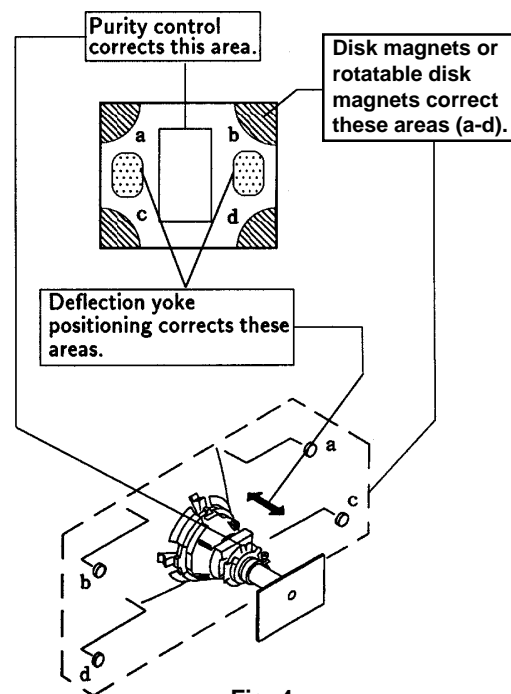

Fig. 4

3-2. CONVERGENCE

Preparation:

- Before starting, perform FOCUS, V. LIN and V. SIZE adjustments.
- Set BRIGHTNESS control to minimum.
- Feed in dot pattern.

(1) Vertical Static Convergence

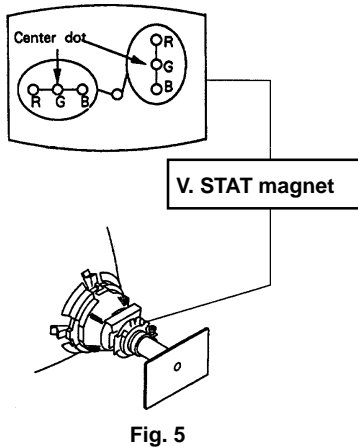

1. Adjust V. STAT magnet to converge red, green and blue dots in the center of the screen. (Vertical movement)

Tilt the V. STAT magnet and adjust static convergence to open or close the V. STAT magnet.

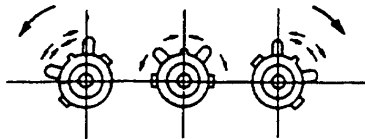

2. When the V. STAT magnet is moved in the direction of arrow (a) and (b), red, green, and blue dots move as shown below:

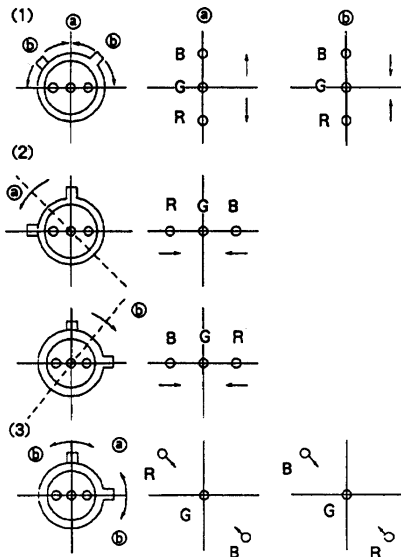

If the blue dot does not converge with red and green dots, perform the following steps:

- Move BMC magnet (a) to correct insufficient H. Static convergence.
- Rotate BMC magnet (b) to correct insufficient V. Static convergence.

In either case, repeat Beam Landing Adjustment.

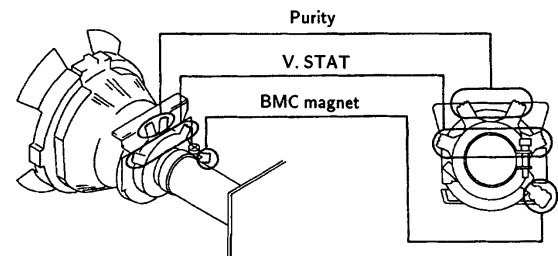
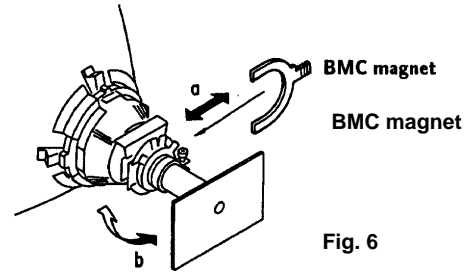

Fig. 7

(2) Dynamic Convergence Adjustment

Preparation:

- Before starting, perform Horizontal and Vertical Static Convergence Adjustment.

1. Slightly loosen deflection yoke screw.
2. Remove deflection yoke spacers.
3. Move the deflection yoke for best convergence as shown below. (Fig. 8)
4. Tighten the deflection yoke screw.
5. Install the deflection yoke spacers.

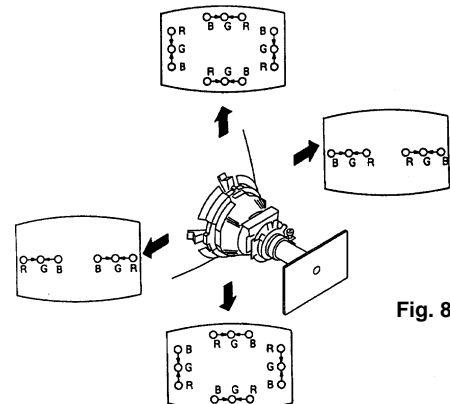

Fig. 8

(3) Screen-corner Convergence

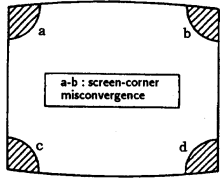
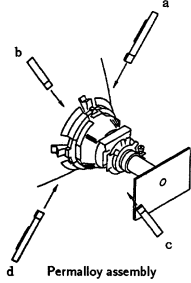

Fig. 9

Affix a permalloy assembly corresponding to the misconverged areas:



3-3. FOCUS

1. Adjust FOCUS control for best picture.

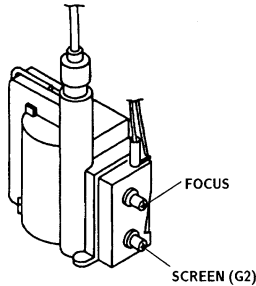

Fig. 10

3-4. SCREEN (G2)

1. Input a dots pattern.
2. Set the PICTURE and BRIGHT controls at minimum and COLOR control at normal.
3. Adjust SBRT, GCUT, BCUT in service mode with an oscilloscope as shown in Fig. 11 so that voltages on the red, green, and blue cathodes are 170Vdc.

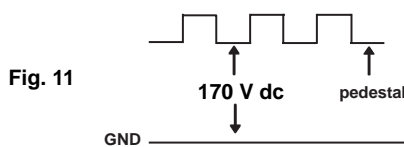

Fig. 11

4. Observe the screen and adjust SCREEN (G2) VR to obtain the faintly visible background of dot signal.

3-5. METHOD OF SETTING THE SERVICE ADJUSTMENT MODE

(1) SERVICE MODE PROCEDURE

1. Standby mode. (Power off)
2. **DISPLAY** → **5** → **VOL(+)** → **POWER** on the Remote Commander. (Press each button within a second.)

(2) SERVICE ADJUSTMENT MODE IN

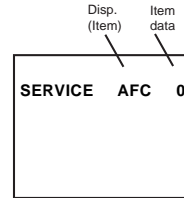

3. The CRT displays the item being adjusted.
4. Press **1** or **4** on the Remote Commander to select the item.
5. Press **3** or **6** on the Remote Commander to change the data.
6. Press **MUTING** then **ENTER** to write into memory.

(3) SERVICE ADJUSTMENT MODE MEMORY



7. Turn set off and on to exit.

3-6. WHITE BALANCE ADJUSTMENTS

1. Input an entire white signal.
2. Set to Service adjustment Mode.
3. Set DCOL to "0"
4. Set the PICTURE and BRIGHT to minimum.
5. Adjust with SBRT if necessary.
6. Select GCUT and BCUT with **1** and **4**.
7. Adjust with **3** and **6** for the best white balance.
8. Set the PICTURE and BRIGHT to maximum.
9. Select GDRV and BDRV with **1** and **4**.
10. Adjust with **3** and **6** for the best white balance.
11. Reset DCOL to "1".
12. Write into the memory by pressing **MUTING** then **ENTER**.

SECTION 5 CIRCUIT ADJUSTMENTS

5-1. ELECTRICAL ADJUSTMENT BY REMOTE COMMANDER

Use Remote Commander (RM-Y167) to perform circuit adjustments on this model.

NOTE : Test Equipment Required:

1. Pattern Generator
2. Frequency Counter
3. Digital Multimeter
4. Audio OSC

7. Press **8** then **ENTER** on the Remote Commander to initialize.



Carry out step 7 when adjusting IDs 0 to 4 and when replacing and adjusting IC003.

(1) Method of Setting the Service Adjustment Mode

SERVICE MODE PROCEDURE

1. Standby mode. (Power off)
2. **DISPLAY** → **5** → **VOL (+)** → **POWER** on the Remote Commander. (Press each button within a second.)

SERVICE ADJUSTMENT MODE IN

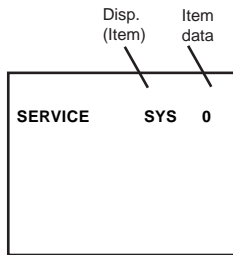

3. The CRT displays the item being adjusted.
4. Press **1** or **4** on the Remote Commander to select the item.
5. Press **3** or **6** on the Remote Commander to change the data.
6. Press **MUTING** then **ENTER** to write into memory.

SERVICE ADJUSTMENT MODE MEMORY

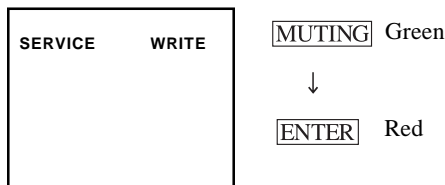

(2) Memory Write Confirmation Method

1. After adjustment, pull out the plug from the AC outlet, then replace the plug in the AC outlet again.
2. Turn the power switch ON and set to service mode.
3. Call the adjusted items again to confirm they were adjusted.

(3) Adjust Buttons and Indicator

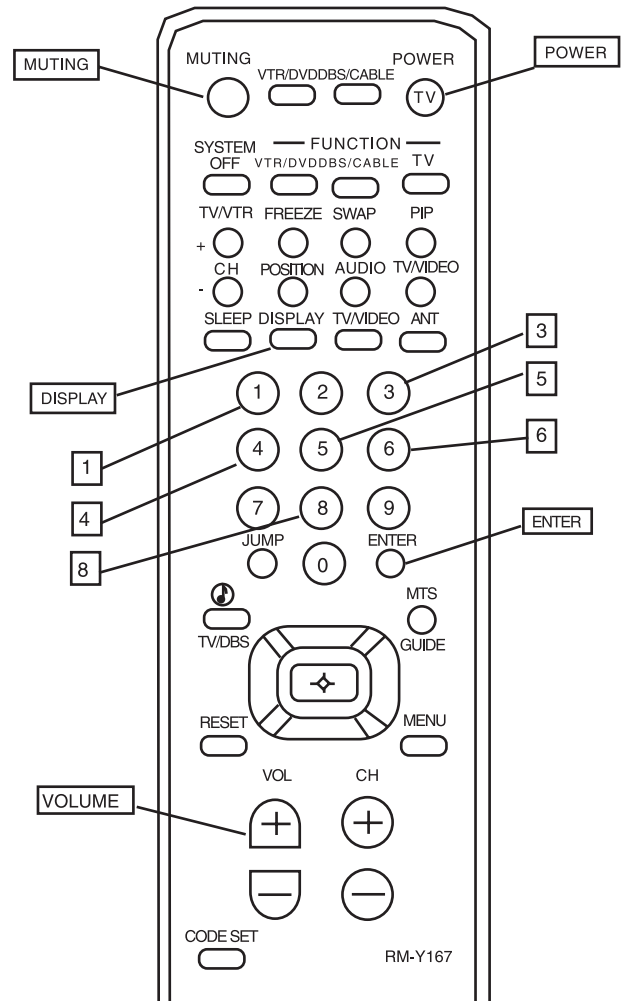

RM-Y167

(4) Item of Adjustments

NO.	ITEM	FUNCTION	DATA RANGE	INITIAL DATA				AVERAGE DATA
				NTSC	PAL-M	PAL-N	VIDEO	
1	HSIZ	HORIZONTAL AMP. ADJ.	0-63	45	45	45		48
2	HPOS	HORIZONTAL POS. ADJ.	0-63	10	10	10		10
3	VBOW	VRT LINE BOWING ADJ.	0-15		6			6
4	VANG	VRT LINE BOW SLANT ADJ.	0-15		5			5
5	TRAP	HORIZ. TRAPEZOID ADJ.	0-15		7			5
6	PAMP	HORIZ. PIN DISTORTION ADJ.	0-63	20	20	20		30
7	CPIN	SAME AS PAMP-SCRN TP/BTM	0-63	40	40	40		30
8	VSIZ	VERTICAL AMP. ADJUST	0-63	31	31	38		35
9	VPOS	VERTICAL POSITION ADJ.	0-63	35	35	35		35
10	VLIN	VERTICAL LINEARITYADJ.	0-15	6	6	6		6
11	SCOR	VERTICAL AMOUNT ADJ.	0-15	8	8	8		8
12	VZOM	16:9 CRT Z MODE ON/OFF	0,1		0			0
13	EHT	VRT HI-VOLT. CORRECTION	0-15		4			4
14	ASP	ASPECT RATIO CONTROL	0-63		47			47
15	SCRL	16:9 CRT Z MODE TRAN SCRL	0-63		31			31
16	HBLK	RGB OUT WIDTH CONTROL	0,1		1			1
17	LBLK	LEFT SCREEN HBLK CONTROL	0-15		15			15
18	RBLK	RGT SCREEN HBLK CONTROL	0-15		3			3
19	VUSN	V SAW WAVEFORM COMPRES	0,1		0			0
20	HDW	H. DRIVE PULSE WIDTH	0,1		0			0
21	EWDC	EW/DC ADJUST	0,1		0			0
22	LVLN	SCREEN BTM VRT LIN ADJUST	0-15		0			0
23	UVLN	SCREEN TOP VRT LIN ADJUST	0-15		0			0
24	RDRV	R OUTPUT DRIVE CONTROL	0-63		35			40
25	GDRV	G OUTPUT DRIVE CONTROL	0-63		30			35
26	BDRV	B OUTPUT DRIVE CONTROL	0-63		30			35
27	RCUT	R OUTPUT CUTOFF CONTROL	0-15		10			7
28	GCUT	G OUTPUT CUTOFF CONTROL	0-15		7			5
29	BCUT	B OUTPUT CUTOFF CONTROL	0-15		7			5
30	DCOL	DYNAMIC COLOR ON/OFF	0,1		0			1
31	SHUE	SUB HUE	0-31		14			8
32	SCOL	SUB COLOR	0-31	14	14	14		14
33	SBRT	SUB BRIGHTNESS	0-31		11			12
34	RON	R OUTPUT ON/OFF	0,1		1			1
35	GON	G OUTPUT ON/OFF	0,1		1			1
36	BON	B OUTPUT ON/OFF	0,1		1			1
37	AXPL	AXIS PAL	0,1		0			0
38	AXNT	AXIS NTSC	0,1		0			0
39	CBPF	CHROMA BPF ON/OFF	0,1		0*, 1**			
40	CTRP	Y TRAP FILTER ON/OFF	0,1		1*, 0**			
41	COFF	COLOR ON/OFF	0,1		0			0
42	KOFF	SET COLOR KILLER	0,1		0			0
43	SSHP	SUB SHARPNESS	0-15		7			7
44	SHPF	SHARPNESS CIRCUIT F0	0,1		1		1	1
45	PREL	PRE/OVR SHOOT SWITCHING	0,1		1			1
46	Y-DC	DC TRANS RATIO SWITCHING	0,1		1			1
47	GAMM	GAMMA CORRECTION AMNT	0-3		0			0
48	ABLM	ABL MODE SWITCHING	0,1		1			1
49	VTH	ABL C D VTH SWITCHING	0,1		1			1
50	YDEL	Y DELAY TIME CONTROL	0-15		7			7
51	NCOL	NO COLOR ID	0,1		1			1
52	FSC	FSC OUT ON/OFF	0,1		1*, 0**			
53	K-ID	KILLER ID CONTROL SW	0,1		0			0
54	HOSC	H VCO OSCILLATION FREQ	0-15		7			7
55	VSS	V SYNC SLICE LEVEL	0,1		0			0
56	HSS	H SYNC SLICE LEVEL	0,1		0			0
57	HMSK		0,1		1			1
58	VTMS	SELECT SIGNAL VTIM PIN	0-3		0			0
59	CDMD	V CNT DWN MODE SWITCHING	0-3		0		1	
60	AFC	AFC LOOP GAIN SWITCHING	0-3		0		0	

NO.	ITEM	FUNCTION	DATA RANGE	INITIAL DATA				AVERAGE DATA
				NTSC	PAL-M	PAL-N	VIDEO	
61	FIFR	FIELD FREQUENCY	0-3	3*, 1**				
62	SBAL	SUB BALANCE	0-31	14			14	
63	DISP	OSD POSITION	0-127	15			15	
64	PADJ	POWER ADJUSTMENT	0-63	3			3	
65	PSHP	PIP SUB SHARPNESS	0-15	7			7	
66	PPIX	PIP SUB CONTRAST	0-15	7			7	
67	PHUE	PIP SUB HUE	0-15	3			3	
68	PCOL	PIP SUB COLOR	0-15	5	5	5	5	
69	PTRP	PIP C TRAP F0	0-15	7			7	
70	PAFC	PIp AFC	0-3	1		1	1	
71	PYDR	PIP Y DRIVE	0-31	14			14	
72	UPED	U PED	0-15	8			8	
73	VPED	V PED	0-15	8			8	
74	U2PE	U2 PED	0-15	5			5	
75	V2PE	V2 PED	0-15	5			5	
76	Y2DR	Y2 DRIVE	0-31	20			20	
77	U2DR	U2 DRIVE	0-31	18			18	
78	V2DRV	V2 DRIVE	0-31	9			9	
79	PSFO	PIP SHP F0	0,1	1			1	
80	PCD2	PIP CD MODE 2	0,1	1		1	1	
81	PDCT	PIP DC TRAN	0-7	4			4	
82	PP/O	PIP PRE/OVER	0-3	1			1	
83	PDLY	PIP Y DELAY	0-3	0			0	
84	PBG	PIP BG	0-15	5			5	
85	PEXT	PIP EXT COLOR	0,1	1*, 0**			1** 0*	
86	PHMK		0,1	0			0	
87	ABLO		0,1	0			0	
88	ABL1		0-7	1			1	
89	PHPO	PIP HORIZONTAL POSITION	0-63	58			58	
90	PVPO	PIp VERTICAL POSITION	0-31	18			18	
91	PYSD	PIP YS DELAY	0-15	1			1	
92	PYDL	PIP Y INPUT DELAY	0-7	0			0	
93	PHVI	PIP HV SYNC	0,1	0			0	
94	PCLP	PIP CLAMP	0-3	0			0	
95	PCLK	PIP CLOCK	0,1	1			1	
96	PIHS	INSET HORIZONTAL SYNC	0-15	2			2	
97	PIVS	INSET VERTICAL SYNC	0-63	22			22	
98	PMVS	MAIN VERTICAL SYN	0-63	17			17	
99	PCON	PIP CONTRAST	0-15	10			10	
100	PFRY	PIP FRAME Y	0-15	5			5	
101	PFRY	PIP FRAME CHROMA	0-255	0			0	
102	PFRW	PIP FRAME WIDTH	0-31	20			20	
103	PSEL	PIP SEL	0,1	1			1	
104	PPLL	PIP PLL	0-3	0			0	
105	PVPE	PIP V PED	0-15	0			0	
106	PUPE	PIP U PED	0-15	0			0	

* NTSC MODELS

** TRINORMA MODELS

SERVICE ID0 25

Note: No. 1 through 106 show adjustment order.

(5) Feature ID Map

	KV-	DESTINATION	ID-0	ID-1	ID-2	ID-3	ID-4	ID-5	ID-6	ID-7
1	27S40	(US)	153	1	13	195	31	1	0	64
2	27S40	(CND)	129	1	13	195	31	1	0	64
3	27S45	(US)	153	27	13	195	31	1	1	64
4	27S45	(CND)	129	27	13	195	31	1	1	64
5	27S65	(US)	153	27	15	195	31	1	7	64
6	27S65	(CND)	129	27	15	195	31	1	7	64
7	29SL40	(E)	145	1	141	195	63	1	0	64
8	29SL40A	(E)	151	1	141	195	55	1	0	64
9	29SL40C	(E)	145	1	141	195	63	1	0	64
10	29SL45	(E)	145	27	141	195	63	1	1	64
11	29SL65	(E)	145	27	143	195	63	1	7	64
12	29SL65C	(E)	145	19	143	195	63	1	7	64
13	29XL40M	(MX)	145	1	141	195	63	1	0	64
14	29XL40P	(E)	145	1	141	195	63	1	0	64
15	29XT11A	(E)	151	1	141	195	55	1	0	64

5-2. A BOARD ADJUSTMENTS

H. FREQUENCY ADJUSTMENT

1. Input a monoscope signal.
2. Set to Service adjustment Mode.
3. Connect a frequency counter to base of Q501 (TP-500 H. DRIVE).
4. Select the item of AFC, set to 3 level (free run).
5. Check H. Frequency for the 15735 ± 200 Hz. (NTSC) or check H. Frequency for the 15650 ± 200 Hz. (Trinorma)
6. Select the item of AFC again, adjust the level "0".
7. Write into the memory by pressing **MUTING** then **ENTER**.

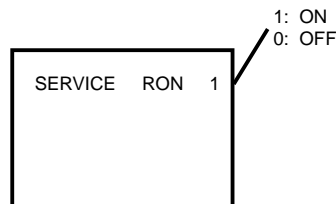

6. Connect an oscilloscope probe to C Board, CN301 Pin ⑤ (RED OUT).
7. Select RDRV with **1** and **4**.
8. Adjust with **3** and **6** for: 1.90 ± 0.05 Vp-p.

V. FREQUENCY ADJUSTMENT

1. Select video 1 with no signal input.
2. Set the conditions with standard setting.
3. Connect the frequency counter across TP-508 or CN501 VDY (+) pin ⑥ connector and ground.
4. Check V. Frequency for the 60 ± 2 Hz (NTSC)
5. Check V. Frequency for the 50 ± 2 Hz (Trinorma).

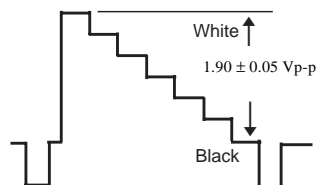

9. Reset the item DCOL to "1" level.
10. Write the memory by pressing **MUTING** then **ENTER**.
11. Return the following back to normal after adjustment.

SUB CONTRACT ADJUSTMENT (SCON)

1. Input a color-bar signal.
2. Select the red color.
3. Set to Service adjustment Mode.
4. Select the item DCOL to "0" level.
5. Set the conditions as follows.

PICTURE MAX
COLOR MIN
BRIGHT CENTER

R ON ON (1)
G ON OFF (0)
B ON OFF (0)

PICTURE MAX
COLOR CENTER
BRIGHT CENTER

R ON ON (1)
G ON ON (1)
B ON ON (1)

DISPLAY POSITION ADJUSTMENT (DISP)

1. Input a color-bar signal.
2. Set to Service adjustment Mode.
3. Select DISP with **[1]** and **[4]**.
4. Adjust with **[3]** and **[6]** for adjustment of characters to center.
5. Write the memory by pressing **[MUTING]** then **[ENTER]**.
6. Check if the text is displayed on the screen.

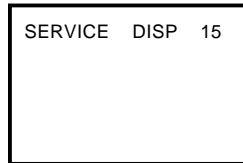

SUB BRIGHT ADJUSTMENT (SBRT)

1. Input a cross-hatch signal.
2. Set to Service adjustment Mode.
3. Set the PICTURE and BRIGHT to minimum.
4. Select SBRT with **[1]** and **[4]**.
5. Adjust with **[3]** and **[6]** to obtain a faintly visible cross-hatch.
6. Write into the memory by pressing **[MUTING]** then **[ENTER]**.

SUB HUE, SUB COLOR ADJUSTMENT (SHUE, SCOL)

1. Input a color-bar signal.
2. Set to Service adjustment Mode.
3. Select the item DCOL and set to "0" level.
4. Connect oscilloscope probe to C Board, CN301 Pin ⑦ (BLUE OUT).
5. Select SHUE and SCOL with **[1]** and **[4]**.
6. Adjust with **[3]** and **[6]** for the $V1 = V4 \pm 0.1V_{p-p}$ (SCOL) and $V2 = V3 \pm 0.1V_{p-p}$ (SHUE).

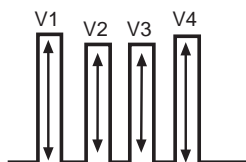

7. Reset the item DCOL to "1" level.
8. Write into the memory by pressing **[MUTING]** then **[ENTER]**.

V. SIZE ADJUSTMENT (VSIZ)

1. Input a cross-hatch signal.
2. Set to Service adjustment mode.
3. Select VSIZ with **[1]** and **[4]**.
4. Adjust with **[3]** and **[6]** for the best vertical size.

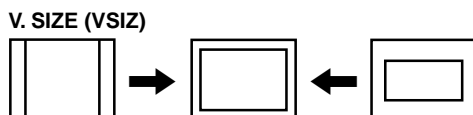

V. CENTER ADJUSTMENT (VPOS)

1. Input a cross-hatch signal.
2. Set to Service adjustment Mode.
3. Select VPOS with **[1]** and **[4]**.
4. Adjust with **[3]** and **[6]** for the best vertical center.
5. Write into the memory by pressing **[MUTING]** then **[ENTER]**.

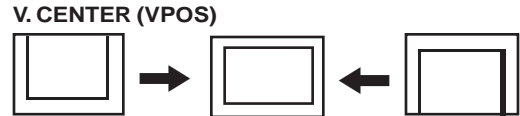

H. CENTER ADJUSTMENT (HPOS)

Note : Perform this adjustment after checking H. FREQUENCY.

1. Input a cross-hatch signal.
2. Set the Service adjustment Mode.
3. Select HPOS with **[1]** and **[4]**.
4. Adjust with **[3]** and **[6]** for the best horizontal center.
5. Write into the memory by pressing **[MUTING]** then **[ENTER]**.

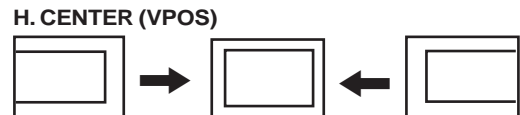

V. LINEARITY (VLIN) AND V CORRECTION

1. Input a cross-hatch signal.
2. V. Correction is automatically adjusted from the circuit and should satisfy the conditions below:

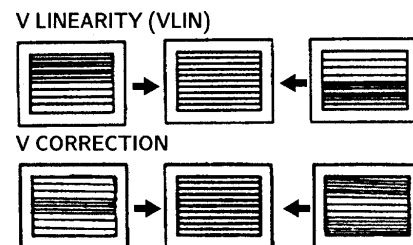

SERVICE ADJUSTMENT MODE MEMORY

1. Change DCOL to "1".
2. After completing all adjustments, press "0" then **[ENTER]**.

READ FROM MEMORY

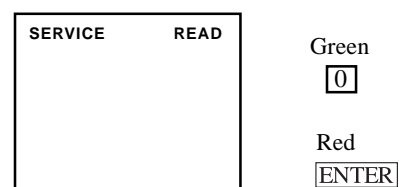

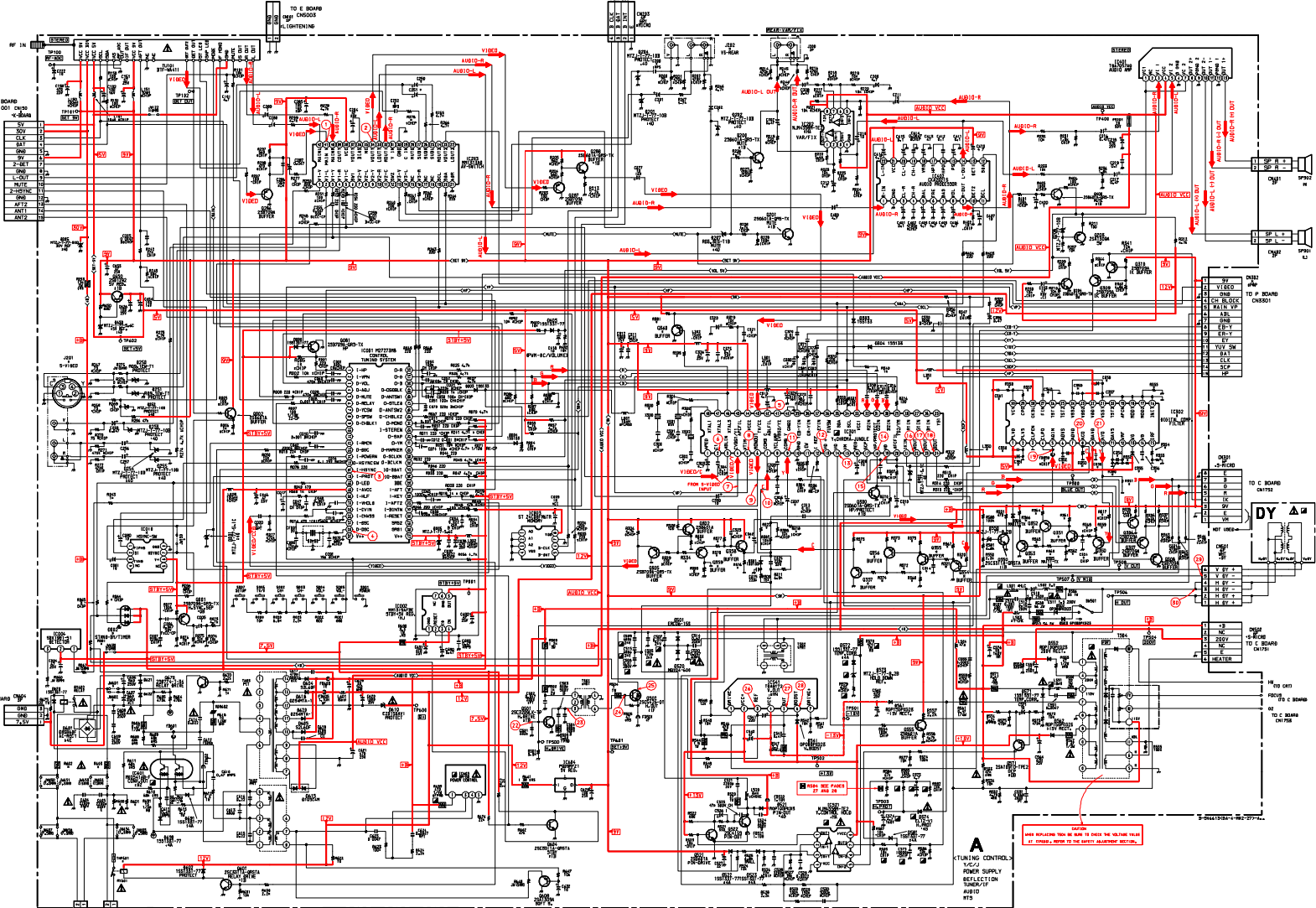

NOTE: SEE EXPLANATION THEREOF IN THE OTHER PARTS OF THIS SET IN THE SERVICE ALIGNMENT SECTION.

A
TUNING CONTROL
POWER SUPPLY
SELECTION
TUNING
Etc.

TO E BOARD
CN502

TO P BOARD
CN501

TO C BOARD
CN720

TO C BOARD
CN721

TO C BOARD
CN722

TO E BOARD
CN502

1

2

3

4

5

A

B

C

D

TO A BOARD
CN150

CN1001
15P
WHT
:5-MICRO

5V	1
30V	2
CLK	3
DATA	4
GND	5
9V	6
2-BET	7
GND	8
L-OUT	9
MUTE	10
2-HSYNC	11
GND	12
2-AFT	13
ANT1	14
ANT2	15

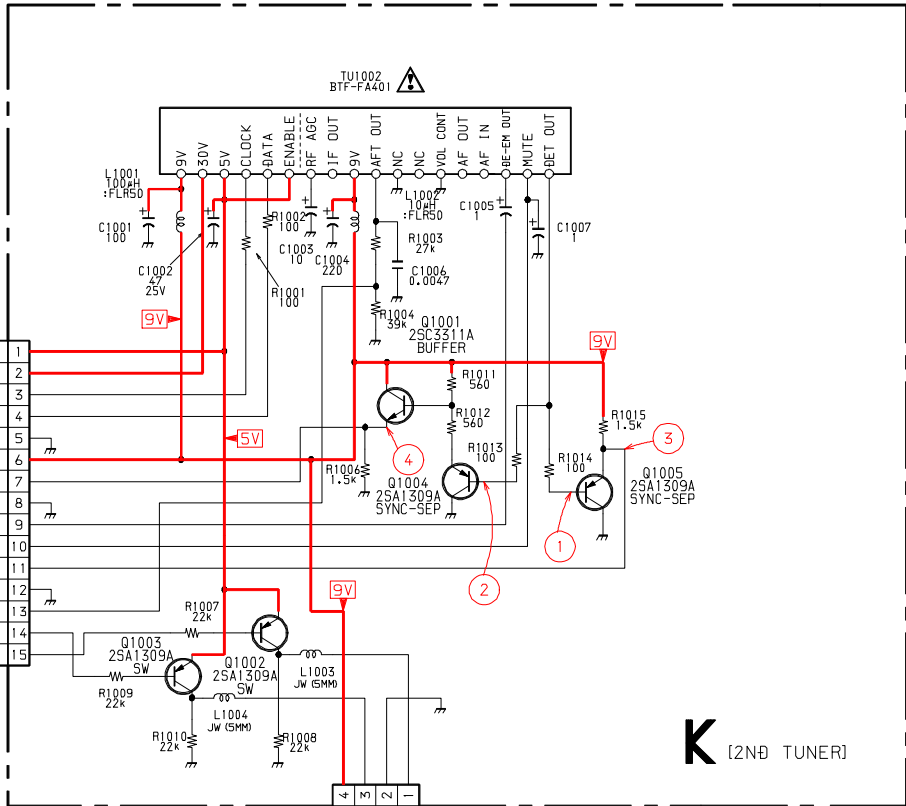

TO ANTENNA
SWITCH

9V
ANT1
E
ANT2

CN1002
4P
WHT
:5-MICRO

K [2ND TUNER]

B-SV6613<BA-4-M#2-27>-K..

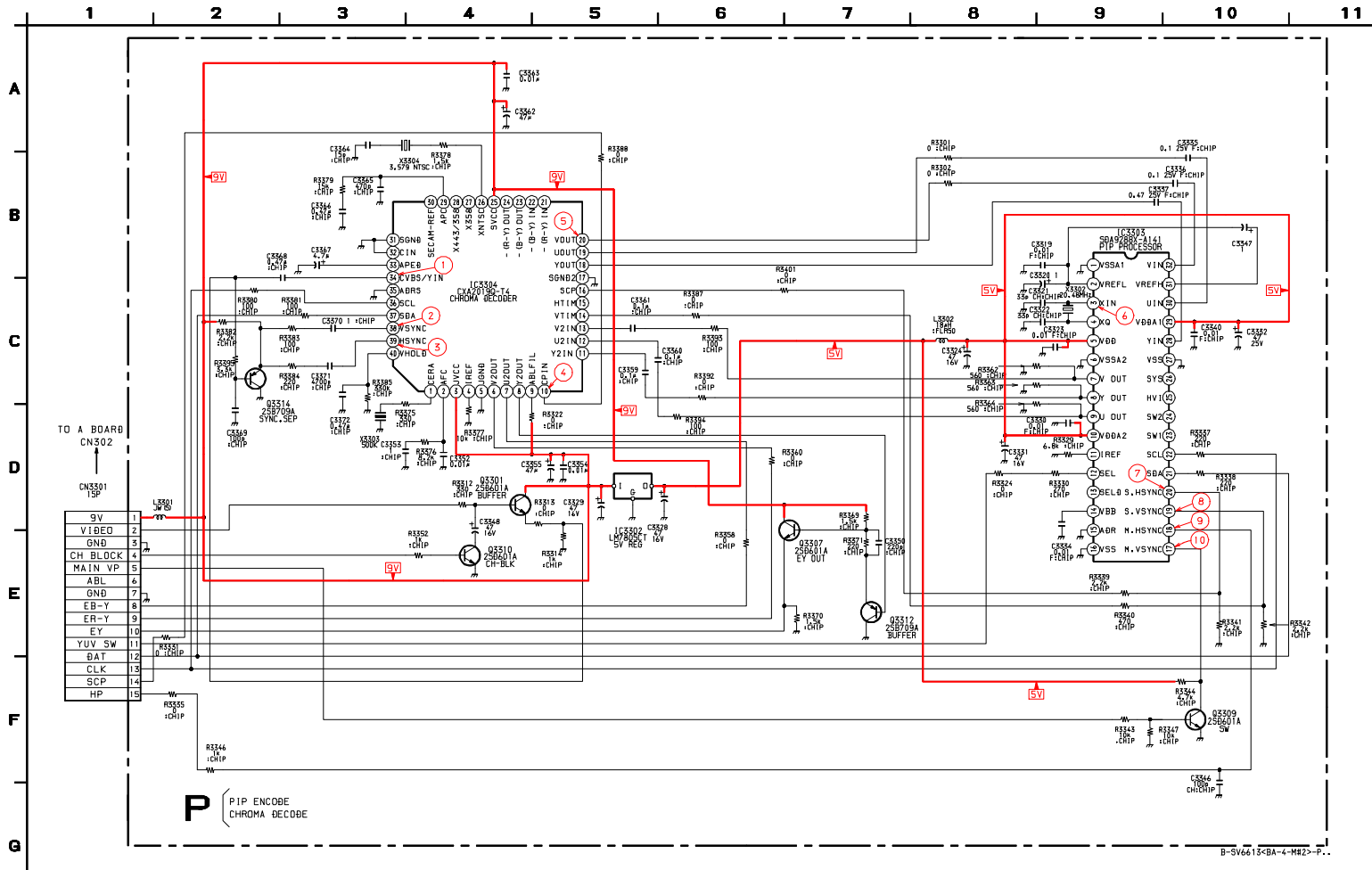

TO A BOARD
CN302

9V	1
VIDEO	2
GND	3
CH BLOCK	4
MAIN VP	5
ABL	6
GND	7
EB-Y	8
ER-Y	9
EY	10
YUV SW	11
BAT	12
CLK	13
SCP	14
HP	15

P PIP ENCODE
CHROMA DECODE

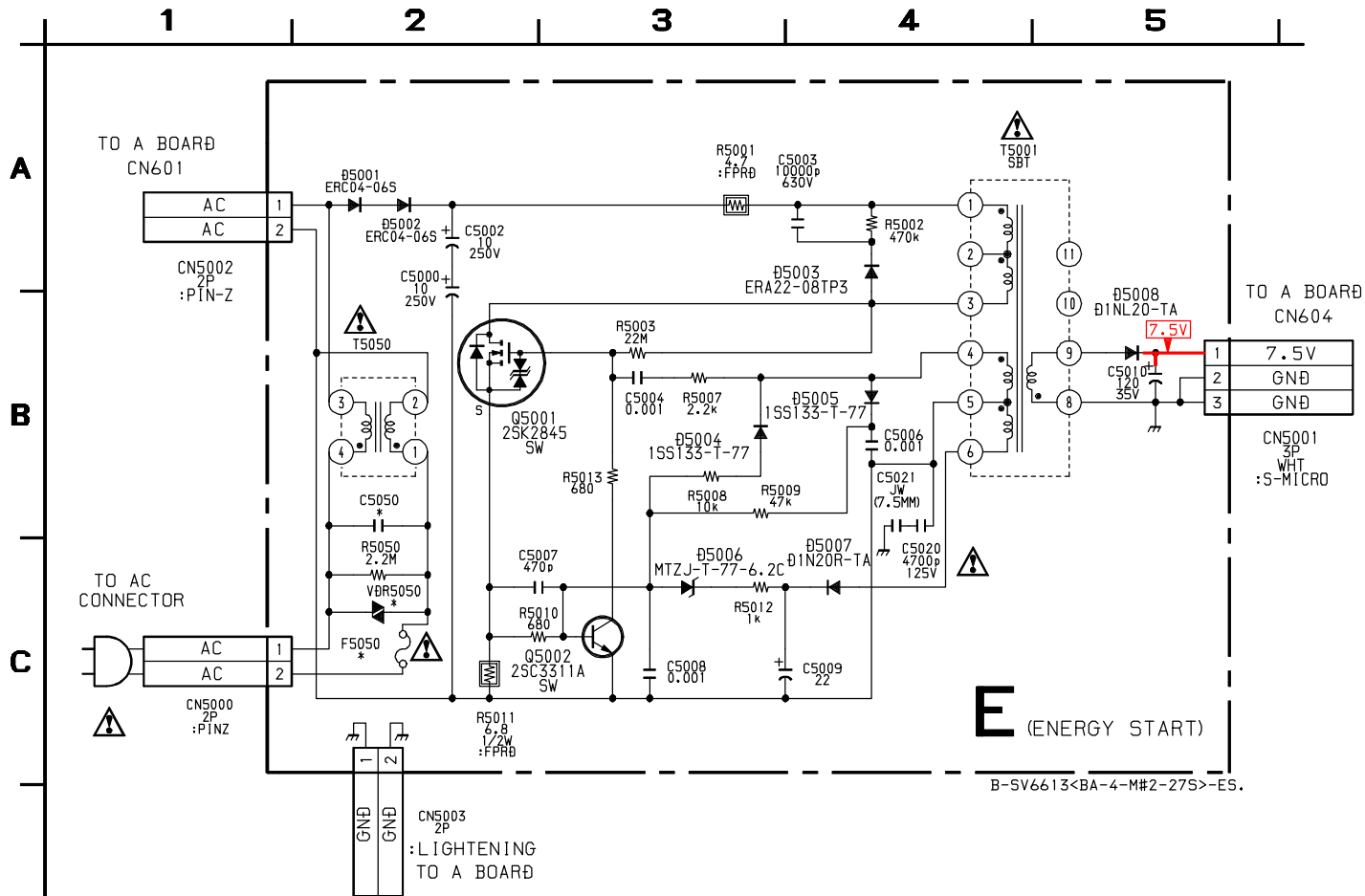

1**2****3****A****B**