

# TOSHIBA

FILE NO. 050-200601GR  
(MFR'S VERSION B)

## SERVICE MANUAL

## COLOR TELEVISION

# 20AF46 20AF46C

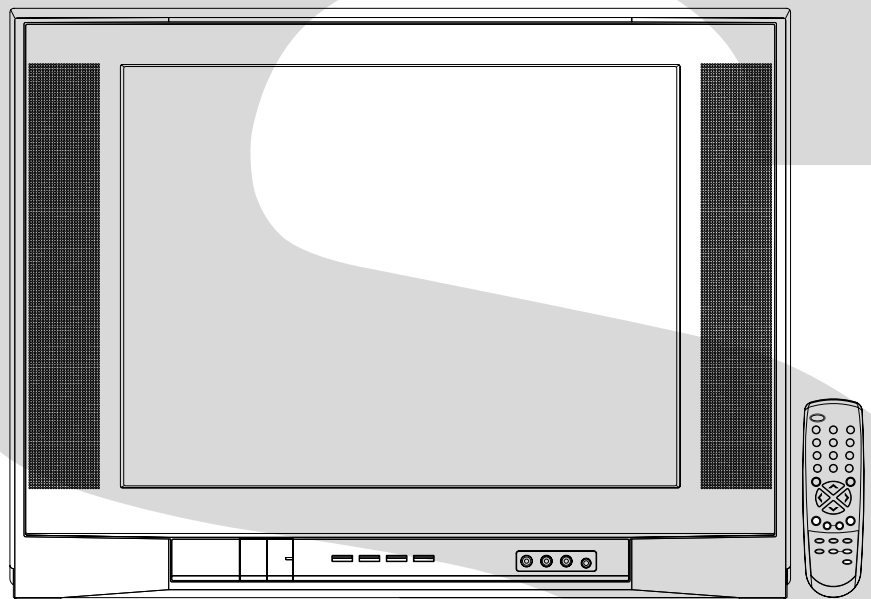

The above model is classified as a green product (\*1), as indicated by the underlined serial number. This Service Manual describes replacement parts for the green product. When repairing this green product, use the part(s) described in this manual and lead-free solder (\*2).

For (\*1) and (\*2), see the next page.

(\*1)

## GREEN PRODUCT PROCUREMENT

The EC is actively promoting the WEEE & RoHS Directives that define standards for recycling and reuse of Waste Electrical and Electronic Equipment and for the Restriction of the use of certain Hazardous Substances. From July 1, 2006, the RoHS Directive will prohibit any marketing of new products containing the restricted substances.

Increasing attention is given to issues related to the global environmental. Toshiba Corporation recognizes environmental protection as a key management tasks, and is doing its utmost to enhance and improve the quality and scope of its environmental activities. In line with this, Toshiba proactively promotes Green Procurement, and seeks to purchase and use products, parts and materials that have low environmental impacts.

Green procurement of parts is not only confined to manufacture. The same green parts used in manufacture must also be used as replacement parts.

(\*2)

## LEAD-FREE SOLDER

This product is manufactured using lead-free solder as a part of a movement within the consumer products industry at large to be environmentally responsible. Lead-free solder must be used in the servicing and repair of this product.

### WARNING

**This product is manufactured using lead free solder.**

### **DO NOT USE LEAD BASED SOLDER TO REPAIR THIS PRODUCT !**

The melting temperature of lead-free solder is higher than that of leaded solder by 86°F to 104°F (30°C to 40°C). Use of a soldering iron designed for lead-based solders to repair product made with lead-free solder may result in damage to the component and or PCB being soldered. Great care should be made to ensure high-quality soldering when servicing this product — especially when soldering large components, through-hole pins, and on PCBs — as the level of heat required to melt lead-free solder is high.

## SERVICING NOTICES ON CHECKING

### 1. KEEP THE NOTICES

As for the places which need special attentions, they are indicated with the labels or seals on the cabinet, chassis and parts. Make sure to keep the indications and notices in the operation manual.

### 2. AVOID AN ELECTRIC SHOCK

There is a high voltage part inside. Avoid an electric shock while the electric current is flowing.

### 3. USE THE DESIGNATED PARTS

The parts in this equipment have the specific characters of incombustibility and withstand voltage for safety. Therefore, the part which is replaced should be used the part which has the same character.

Especially as to the important parts for safety which is indicated in the circuit diagram or the table of parts as a  $\triangle$  mark, the designated parts must be used.

### 4. PUT PARTS AND WIRES IN THE ORIGINAL POSITION AFTER ASSEMBLING OR WIRING

There are parts which use the insulation material such as a tube or tape for safety, or which are assembled in the condition that these do not contact with the printed board. The inside wiring is designed not to get closer to the pyrogenic parts and high voltage parts. Therefore, put these parts in the original positions.

### 5. TAKE CARE TO DEAL WITH THE CATHODE-RAY TUBE

In the condition that an explosion-proof cathode-ray tube is set in this equipment, safety is secured against implosion. However, when removing it or serving from backward, it is dangerous to give a shock. Take enough care to deal with it.

### 6. AVOID AN X-RAY

Safety is secured against an X-ray by considering about the cathode-ray tube and the high voltage peripheral circuit, etc.

Therefore, when repairing the high voltage peripheral circuit, use the designated parts and make sure not modify the circuit.

Repairing except indicates causes rising of high voltage, and it emits an X-ray from the cathode-ray tube.

### 7. PERFORM A SAFETY CHECK AFTER SERVICING

Confirm that the screws, parts and wiring which were removed in order to service are put in the original positions, or whether there are the portions which are deteriorated around the serviced places serviced or not. Check the insulation between the antenna terminal or external metal and the AC cord plug blades. And be sure the safety of that.

#### (INSULATION CHECK PROCEDURE)

1. Unplug the plug from the AC outlet.
2. Remove the antenna terminal on TV and turn on the TV.
3. Insulation resistance between the cord plug terminals and the eternal exposure metal **[Note 2]** should be more than 1M ohm by using the 500V insulation resistance meter **[Note 1]**.
4. If the insulation resistance is less than 1M ohm, the inspection repair should be required.

#### **[Note 1]**

If you have not the 500V insulation resistance meter, use a Tester.

#### **[Note 2]**

External exposure metal: Antenna terminal  
Headphone jack

## HOW TO ORDER PARTS

Please include the following informations when you order parts. (Particularly the VERSION LETTER.)

#### 1. MODEL NUMBER and VERSION LETTER

The MODEL NUMBER can be found on the back of each product and the VERSION LETTER can be found at the end of the SERIAL NUMBER.

#### 2. PART NO. and DESCRIPTION

You can find it in your SERVICE MANUAL.

## IMPORTANT

When you exchange IC and Transistor with a heat sink, apply silicon grease on the contact section of the heat sink. Befor applying new silicon grease, remove all the old silicon grease. (Old grease may cause damages to the IC and Transistor.)

# TABLE OF CONTENTS

<b>GREEN PRODUCT PROCUREMENT</b> .....	A1-1
<b>LEAD-FREE SOLDER</b> .....	A1-1
<b>SERVICING NOTICES ON CHECKING</b> .....	A1-2
<b>HOW TO ORDER PARTS</b> .....	A1-2
<b>IMPORTANT</b> .....	A1-2
<b>TABLE OF CONTENTS</b> .....	A2-1
<b>GENERAL SPECIFICATIONS</b> .....	A3-1~A3-10
<b>DISASSEMBLY INSTRUCTIONS</b>	
1. REMOVAL OF ANODE CAP .....	B1-1
2. REMOVAL AND INSTALLATION OF FLAT PACKAGE IC .....	B2-1, B2-2
<b>SERVICE MODE LIST</b> .....	C-1
<b>CONFIRMATION OF HOURS USED</b> .....	C-1
<b>WHEN REPLACING EEPROM (MEMORY) IC</b> .....	C-2
<b>ELECTRICAL ADJUSTMENTS</b> .....	D-1~D-5
<b>BLOCK DIAGRAM</b> .....	E-1, E-2
<b>PRINTED CIRCUIT BOARDS</b>	
MAIN/CRT .....	F-1~F-4
<b>SCHEMATIC DIAGRAMS</b>	
MICON .....	G-1, G-2
CHROMA .....	G-3, G-4
DEFLECTION .....	G-5, G-6
POWER .....	G-7, G-8
SOUND .....	G-9, G-10
TUNER/STEREO .....	G-11, G-12
COMB FILTER/AV .....	G-13, G-14
CRT .....	G-15, G-16
<b>WAVEFORMS</b> .....	H-1, H-2
<b>MECHANICAL EXPLODED VIEWS</b> .....	I-1, I-2
<b>MECHANICAL REPLACEMENT PARTS LIST</b> .....	J1-1, J1-2
<b>ELECTRICAL REPLACEMENT PARTS LIST</b> .....	J2-1~J2-8

# GENERAL SPECIFICATIONS

G-1	TV System	CRT	CRT Size / Visual Size	20 inch / 508mmV	
			CRT Type	Flat	
			Magnetic Field	BV/BH	+0.45G/0.18G
		Color System			NTSC
		Speaker			2 Speaker
			Position		Front Side
			Size		2 x 4.7 Inch
			Impedance		8 ohm
		Sound Output	MAX		2.5+2.5 W
			10%(Typical)		- W
		NTSC3.58+4.43 /PAL60Hz		No	
G-2	Tuning System	Broadcasting System		US System M	
		Tuner and Receive CH	System	1Tuner	
			Destination	USA(W/ Cable)	
			CH Coverage	2 - 69, 4A, A-5 - A-1, A - I, J - W, W+1 - W+84	
		Intermediate Frequency	Picture(FP)		45.75MHz
			Sound(FS)		41.25MHz
			FP-FS		4.50MHz
		Preset CH			No
	Stereo/Dual TV Sound		Yes		
	Tuner Sound Muting		Yes		
G-3	Power	Power Source	AC	120V AC 60Hz	
			DC		
		Power Consumption		at AC	
			Stand by (at AC) Per Year		105 W at AC 120 V 60 Hz 3 W at AC 120 V 60 Hz -- kWh/Year
	Protector	Power Fuse		Yes	
		Safety Circuit		Yes	
		IC Protector(Micro Fuse)		No	
G-4	Regulation	Safety		UL	
		Radiation		FCC	
		X-Radiation		DHHS	
G-5	Temperature	Operation		+5oC ~ +40oC	
		Storage		-20oC ~ +60oC	
G-6	Operating Humidity			Less than 80% RH	

# GENERAL SPECIFICATIONS

G-7	On Screen Display	Menu		Yes	
		Menu Type		Icon	
		Picture		Yes	
				Contrast	Yes
				Brightness	Yes
				Color	Yes
				Tint	Yes
				Sharpness	Yes
			Sound		Yes
				Bass	Yes
				Treble	Yes
				Balance	Yes
				BBE On/Off	No
				Stable Sound On/Off	Yes
				Surround On/Off	Yes
			Set Up		Yes
				TV/Cable	Yes
				Auto CH Memory	Yes
				Add/ Delete	Yes
			Option		Yes
				Language	Yes
				CH Label	Yes
				Favorite CH	Yes
				V-Chip	Yes
				Lock	Yes
				On/Off Timer	Yes
				Color Stream DVD/DTV	Yes
			Control Level		Yes
				Volume	Yes
				Brightness	Yes
				Contrast	Yes
				Color	Yes
		Tint	Yes		
		Sharpness	Yes		
		Tuning	No		
		Bass	Yes		
		Treble	Yes		
		Balance	Yes		
		Back Light	No		
		Stereo,Audio Output,SAP	Yes		
		Video	Yes		
		Color Stream	Yes		
		Channel(TV/Cable)	Yes		
		CH Label	Yes		
		Game Timer	Yes		
		Sleep Timer	Yes		
		Sound Mute	Yes		
		V-chip Rating	Yes		
		16: 9	Yes		
G-8	OSD Language		English French Spanish		
G-9	Clock and Timer	Sleep Timer	Max Time	120 Min	
			Step	10 Min	
		On/Off Timer	Program(On Timer / Off Timer / Clock)	Yes	
		Wake Up Timer		No	
	Timer Back-up (at Power Off Mode)	more than	-- Min Sec		

# GENERAL SPECIFICATIONS

<b>G-10</b>	<b>Remote Control</b>	Unit	RC-GQ	
		Glow in Dark Remocon	Yes	
		Format	Toshiba	
		Remocon Format	Toshiba	
		Custom Code	TV:40-BF h	
		Power Source	Voltage(D.C) UM size x pcs	3V UM-4 x 2 pcs
		Total Keys		30 Keys
		Keys	Power	Yes
			1	Yes
			2	Yes
			3	Yes
			4	Yes
			5	Yes
			6	Yes
			7	Yes
			8	Yes
			9	Yes
			0	Yes
			100	Yes
			CH Up	Yes
			CH Down	Yes
			Volume Up	Yes
			Volume Down	Yes
			Cap/Text(TV/Caption/Text)	Yes
			1/2(CH1/CH2)	Yes
			TV/Video(TV/AV)	Yes
			CH RTN(Quick View)	Yes
			Sleep	Yes
			RECall(Call)	Yes
			Reset	Yes
			Menu/Enter	Yes
			Mute	Yes
			Exit	Yes
			MTS(Audio Select)	Yes
			Fav.Up	Yes
			Fav.Down	Yes
			16: 9	Yes
			Multi Brand Keys	
			CH Up(VCR)	No
			CH Down(VCR)	No
			Pause/Still	No
			TV/VCR(VCR)	No
			FF	No
			Rew	No
			Rec	No
			Play	No
			Stop	No
			TV	No
			VCR	No
			Cable	No
			DVD	No
			CODE	No
			DVD MENU <	No
	DVD MENU >	No		
	DVD CLEAR	No		
	TOP MENU	No		
	DVD MENU	No		

## GENERAL SPECIFICATIONS

<b>G-11</b>	<b>Features</b>	Auto Degauss	Yes
		Auto Shut Off	Yes
		Canal+	No
		Cable	Yes
		Anti-theft	No
		Rental	No
		Memory(Last CH)	Yes
		Memory(Last Volume)	Yes
		V-Chip	Yes
		Type	USA, Toshiba Type
		BBE	No
		Auto Search	No
		CH Allocation	No
		SAP	Yes
		Just Clock Function	No
		CH Label	Yes
		VM Circuit	No
		Full OSD	No
		Premiere	No
		Comb Filter	Yes 2 Lines
		Auto CH Memory	Yes
		Hotel Lock	No
		Closed Caption	Yes
		Stable Sound	Yes
		FBT Leak Test Protect	Yes
		CH Lock	Yes
		Video Lock	Yes
		Game Timer (Max Time:120 Min)	Yes
		Energy Star	No
		Favorite CH	Yes
		Surround	Yes
		16:9 Mode	Yes
<b>G-12</b>	<b>Accessories</b>	Owner's Manual	Language W/ Warranty
		Remote Control Unit	English/Spanish Yes
		Rod Antenna	No
		Poles Terminal	
		Loop Antenna	No
		Terminal	-
		U/V Mixer	No
		DC Car Cord (Center+)	No
		Guarantee Card	No
		Warning Sheet	No
		Circuit Diagram	No
		Antenna Change Plug	No
		Service Station List	No
		Important Safety Instruction	No
		Dew/AHC Caution Sheet	No
		AC Plug Adapter	No
		Quick Set-up Sheet	No
		Battery	Yes UM-4 x 2
		UM size x pcs OEM Brand	No
		AC Cord	No
		AV Cord (2Pin-1Pin)	No
		Registration Card (NDL Card)	Yes
		PTB Sheet	No
		ESP Card	No
		300 ohm to 75 ohm Antenna Adapter	No

## GENERAL SPECIFICATIONS

<b>G-13</b>	<b>Interface</b>	Switch	Front	Power	Yes	
				System Select	No	
				Main Power SW	No	
				Sub Power	No	
				Channel Up	Yes	
				Channel Down	Yes	
				Volume Up	Yes	
				Volume Down	Yes	
				Rear	AC/DC	No
		TV/Cable Selector	No			
		Degauss	No			
		Main Power SW	No			
		Indicator	Power	Yes(RED)		
			Stand-by	No		
			On Timer	No		
		Terminals	Front	Video Input = VIDEO2	RCA	
				Audio Input = VIDEO2	RCA x 2(L/MONO,R)	
				Other Terminal	Head Phone	
			Rear	Video Input(Rear1) = VIDEO1	RCA	
				Video Input(Rear2) = VIDEO2	No	
				Audio Input(Rear1) = VIDEO1	RCA x 2(L/MONO,R)	
				Audio Input(Rear2) = VIDEO2	No	
				Video Output	No	
				Audio Output	No	
				Euro Scart	No	
				Color Stream	RCA x 3	
				S Input	Yes	
Diversity	No					
Ext Speaker	No					
DC Jack 12V(Center +)	No					
VHF/UHF Antenna Input	F Type					
AC Outlet	No					
<b>G-14</b>	<b>Set Size</b>			Approx. W x D x H (mm)		<u>590 x 484 x 446.5</u>
<b>G-15</b>	<b>Weight</b>			Net (Approx.)		<u>23 kg (50.6 lbs)</u>
		Gross (Approx.)		<u>26.5 kg (58.3 lbs)</u>		
<b>G-16</b>	<b>Carton</b>	Master Carton	Content	No		
			Material	--- Sets		
			Dimensions W x D x H(mm)	-- x -- x --		
			Description of Origin	No		
		Gift Box	Material	Double/Brown		
			Dimensions W x D x H(mm)	<u>695 x 575 x 549</u>		
			Description of Origin	Yes		
		Drop Test	Natural Dropping At 1 Corner / 3 Edges / 6 Surfaces			
			Height (cm)	60 (ORION SPEC:46)		
		<b>G-17</b>	<b>Cabinet Material</b>	Cabinet	Cabinet Front	PS 94V0 DECABROM
Cabinet Rear	PS 94V0 DECABROM					
PCB	Non-Halogen Demand			No		
	Eyelet Demand			Yes		
	Environmental standard requirement			Green procurement of TOSHIBA		
<b>G-18</b>	<b>Environment</b>	Pb-free		Phase3(Phase3A)		

## GENERAL SPECIFICATIONS

<b>G-1</b>	<b>TV System</b>	CRT	CRT Size / Visual Size	20 inch / 508mmV	
			CRT Type	Flat	
			Magnetic Field	BV/BH	+0.45G/0.18G
		Color System		NTSC	
		Speaker		2 Speaker	
			Position	Front Side	
			Size	2 x 4.7 Inch	
			Impedance	8 ohm	
<b>G-2</b>	<b>Tuning System</b>	Sound Output	MAX	2.5+2.5 W	
			10%(Typical)	- W	
			NTSC3.58+4.43 /PAL60Hz	No	
		Broadcasting System		US System M	
		Tuner and Receive CH	System	1Tuner	
			Destination	USA(W/ Cable)	
			CH Coverage	2 - 69, 4A, A-5 - A-1, A - I, J - W, W+1 - W+84	
		Intermediate Frequency	Picture(FP)	45.75MHz	
	Sound(FS)	41.25MHz			
	FP-FS	4.50MHz			
<b>G-3</b>	<b>Power</b>	Preset CH		No	
		Stereo/Dual TV Sound		Yes	
		Tuner Sound Muting		Yes	
		Power Source	AC	120V AC 60Hz	
			DC		
		Power Consumption		at AC	
			Stand by (at AC)	105 W at AC 120 V 60 Hz	
			Per Year	3 W at AC 120 V 60 Hz	
<b>G-4</b>	<b>Regulation</b>	Protector		-- kWh/Year	
			Power Fuse	Yes	
			Safety Circuit	Yes	
			IC Protector(Micro Fuse)	No	
<b>G-5</b>	<b>Temperature</b>	Safety		CSA	
		Radiation		IC	
		X-Radiation		HWC	
<b>G-6</b>	<b>Operating Humidity</b>	Operation		+5oC ~ +40oC	
		Storage		-20oC ~ +60oC	

# GENERAL SPECIFICATIONS

G-7	On Screen Display	Menu		Yes	
		Menu Type		Icon	
		Picture		Yes	
				Contrast	Yes
				Brightness	Yes
				Color	Yes
				Tint	Yes
				Sharpness	Yes
				Sound	Yes
				Bass	Yes
				Treble	Yes
				Balance	Yes
				BBE On/Off	No
				Stable Sound On/Off	Yes
				Surround On/Off	Yes
				Set Up	Yes
				TV/Cable	Yes
				Auto CH Memory	Yes
				Add/ Delete	Yes
				Option	Yes
				Language	Yes
				CH Label	Yes
				Favorite CH	Yes
				V-Chip	No
				Lock	Yes
				On/Off Timer	Yes
				Color Stream DVD/DTV	Yes
				Control Level	Yes
				Volume	Yes
				Brightness	Yes
				Contrast	Yes
				Color	Yes
				Tint	Yes
		Sharpness	Yes		
		Tuning	No		
		Bass	Yes		
		Treble	Yes		
		Balance	Yes		
		Back Light	No		
		Stereo,Audio Output,SAP	Yes		
		Video	Yes		
		Color Stream	Yes		
		Channel(TV/Cable)	Yes		
		CH Label	Yes		
		Game Timer	Yes		
		Sleep Timer	Yes		
		Sound Mute	Yes		
		V-chip Rating	No		
		16: 9	Yes		
G-8	OSD Language			English French Spanish	
G-9	Clock and Timer	Sleep Timer	Max Time	120 Min	
			Step	<u>  </u> 10 <u>  </u> Min	
		On/Off Timer	Program(On Timer / Off Timer / Clock)	Yes	
		Wake Up Timer		No	
	Timer Back-up (at Power Off Mode)	more than	--	Min Sec	

# GENERAL SPECIFICATIONS

<b>G-10</b>	<b>Remote Control</b>	Unit	RC-GQ		
		Glow in Dark Remocon	Yes		
		Format	Toshiba		
		Remocon Format	Toshiba		
		Custom Code	<u>TV:40-BF h</u>		
		Power Source	Voltage(D.C) UM size x pcs	3V UM-4 x 2 pcs	
		Total Keys		<u>30</u> Keys	
		Keys	Power	Yes	
			1	Yes	
			2	Yes	
			3	Yes	
			4	Yes	
			5	Yes	
			6	Yes	
			7	Yes	
			8	Yes	
			9	Yes	
			0	Yes	
			100	Yes	
			CH Up	Yes	
			CH Down	Yes	
			Volume Up	Yes	
			Volume Down	Yes	
			Cap/Text(TV/Caption/Text)	Yes	
			1/2(CH1/CH2)	Yes	
			TV/Video(TV/AV)	Yes	
			CH RTN(Quick View)	Yes	
			Sleep	Yes	
			RECall(Call)	Yes	
			Reset	Yes	
			Menu/Enter	Yes	
			Mute	Yes	
			Exit	Yes	
			MTS(Audio Select)	Yes	
			Fav.Up	Yes	
			Fav.Down	Yes	
			16: 9	Yes	
			Multi Brand Keys	CH Up(VCR)	No
				CH Down(VCR)	No
				Pause/Still	No
				TV/VCR(VCR)	No
				FF	No
				Rew	No
		Rec		No	
		Play		No	
		Stop		No	
		TV		No	
		VCR		No	
		Cable		No	
		DVD		No	
CODE	No				
DVD MENU <	No				
DVD MENU >	No				
DVD CLEAR	No				
TOP MENU	No				
DVD MENU	No				

## GENERAL SPECIFICATIONS

<b>G-11</b>	<b>Features</b>	Auto Degauss	Yes
		Auto Shut Off	Yes
		Canal+	No
		Cable	Yes
		Anti-theft	No
		Rental	No
		Memory(Last CH)	Yes
		Memory(Last Volume)	Yes
		V-Chip	No
		Type	- Type
		BBE	No
		Auto Search	No
		CH Allocation	No
		SAP	Yes
		Just Clock Function	No
		CH Label	Yes
		VM Circuit	No
		Full OSD	No
		Premiere	No
		Comb Filter	Yes 2 Lines
		Auto CH Memory	Yes
		Hotel Lock	No
		Closed Caption	Yes
		Stable Sound	Yes
		FBT Leak Test Protect	Yes
		CH Lock	Yes
		Video Lock	Yes
		Game Timer (Max Time:120 Min)	Yes
		Energy Star	No
		Favorite CH	Yes
		Surround	Yes
		16:9 Mode	Yes
<b>G-12</b>	<b>Accessories</b>	Owner's Manual	Language W/ Warranty
		Remote Control Unit	English / French Yes
		Rod Antenna	No
		Poles Terminal	
		Loop Antenna	No
		Terminal	-
		U/V Mixer	No
		DC Car Cord (Center+)	No
		Guarantee Card	No
		Warning Sheet	No
		Circuit Diagram	No
		Antenna Change Plug	No
		Service Station List	No
		Important Safety Instruction	No
		Dew/AHC Caution Sheet	No
		AC Plug Adapter	No
		Quick Set-up Sheet	No
		Battery	Yes UM-4 x 2
		UM size x pcs OEM Brand	No
		AC Cord	No
		AV Cord (2Pin-1Pin)	No
		Registration Card (NDL Card)	No
		PTB Sheet	No
		ESP Card	No
		300 ohm to 75 ohm Antenna Adapter	No

# GENERAL SPECIFICATIONS

<b>G-13</b>	<b>Interface</b>	Switch	Front	Power	Yes
				System Select	No
				Main Power SW	No
				Sub Power	No
				Channel Up	Yes
				Channel Down	Yes
				Volume Up	Yes
				Volume Down	Yes
				Rear	AC/DC
		TV/Cable Selector	No		
		Degauss	No		
		Main Power SW	No		
		Indicator	Power	Yes(RED)	
			Stand-by	No	
			On Timer	No	
		Terminals	Front	Video Input = VIDEO2	RCA
				Audio Input = VIDEO2	RCA x 2(L/MONO,R)
				Other Terminal	Head Phone
			Rear	Video Input(Rear1) = VIDEO1	RCA
				Video Input(Rear2) = VIDEO2	No
				Audio Input(Rear1) = VIDEO1	RCA x 2(L/MONO,R)
				Audio Input(Rear2) = VIDEO2	No
				Video Output	No
				Audio Output	No
				Euro Scart	No
				Color Stream	RCA x 3
				S Input	Yes
Diversity	No				
Ext Speaker	No				
DC Jack 12V(Center +)	No				
VHF/UHF Antenna Input	F Type				
AC Outlet	No				
<b>G-14</b>	<b>Set Size</b>	Approx. W x D x H (mm)		<u>590</u> x <u>484</u> x <u>446.5</u>	
<b>G-15</b>	<b>Weight</b>	Net (Approx.)		<u>23 kg</u> ( <u>50.6 lbs</u> )	
		Gross (Approx.)		<u>26.5 kg</u> ( <u>58.3 lbs</u> )	
<b>G-16</b>	<b>Carton</b>	Master Carton		No	
			Content	--- Sets	
			Material	-- /--	
			Dimensions W x D x H(mm)	-- x -- x --	
			Description of Origin	No	
		Gift Box	Material	Double/Brown	
			Dimensions W x D x H(mm)	<u>695</u> x <u>575</u> x <u>549</u>	
			Description of Origin	Yes	
		Drop Test		Natural Dropping At 1 Corner / 3 Edges / 6 Surfaces	
			Height (cm)	60 (ORION SPEC:46)	
	Container Stuffing	<u>272</u> Sets/40' container			
<b>G-17</b>	<b>Cabinet Material</b>	Cabinet	Cabinet Front	PS 94V0 DECABROM	
			Cabinet Rear	PS 94V0 DECABROM	
		PCB	Non-Halogen Demand	No	
			Eyelet Demand	Yes	
<b>G-18</b>	<b>Environment</b>	Environmental standard requirement	Green procurement of TOSHIBA		
		Pb-free	Phase3(Phase3A)		

# DISASSEMBLY INSTRUCTIONS

## 1. REMOVAL OF ANODE CAP

Read the following **NOTED** items before starting work.

- \* After turning the power off there might still be a potential voltage that is very dangerous. When removing the Anode Cap, make sure to discharge the Anode Cap's potential voltage.
- \* Do not use pliers to loosen or tighten the Anode Cap terminal, this may cause the spring to be damaged.

### REMOVAL

1. Follow the steps as follows to discharge the Anode Cap. (Refer to Fig. 1-1.)

Connect one end of an Alligator Clip to the metal part of a flat-blade screwdriver and the other end to ground. While holding the plastic part of the insulated Screwdriver, touch the support of the Anode with the tip of the Screwdriver. A cracking noise will be heard as the voltage is discharged.

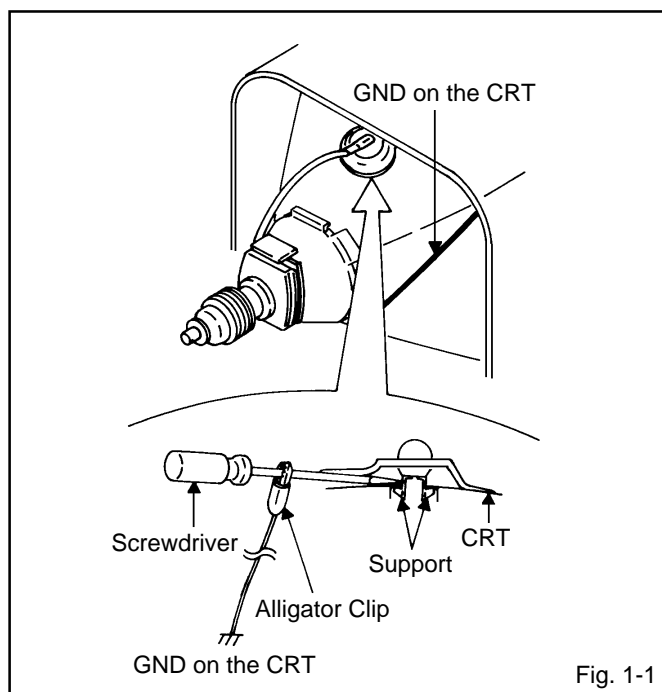

2. Flip up the sides of the Rubber Cap in the direction of the arrow and remove one side of the support. (Refer to Fig. 1-2.)

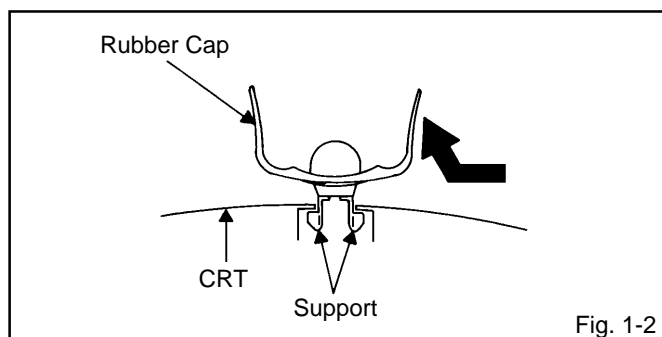

3. After one side is removed, pull in the opposite direction to remove the other.

### NOTE

Take care not to damage the Rubber Cap.

### INSTALLATION

1. Clean the spot where the cap was located with a small amount of alcohol. (Refer to Fig. 1-3.)

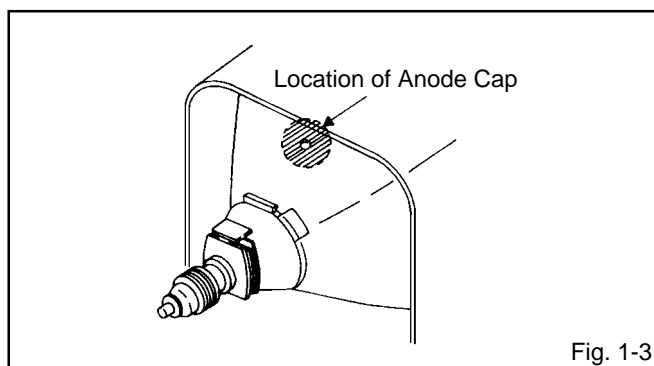

### NOTE

Confirm that there is no dirt, dust, etc. at the spot where the cap was located.

2. Arrange the wire of the Anode Cap and make sure the wire is not twisted.
3. Turn over the Rubber Cap. (Refer to Fig. 1-4.)

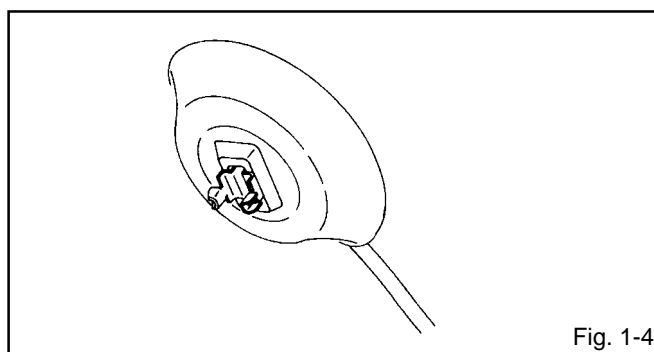

4. Insert one end of the Anode Support into the anode button, then the other as shown in Fig. 1-5.

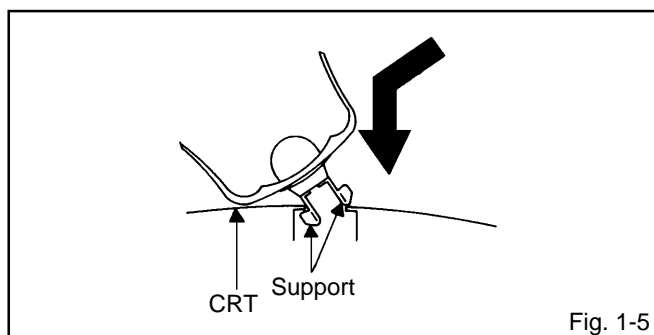

5. Confirm that the Support is securely connected.
6. Put on the Rubber Cap without moving any parts.

# DISASSEMBLY INSTRUCTIONS

## 2. REMOVAL AND INSTALLATION OF FLAT PACKAGE IC

### REMOVAL

1. Put Masking Tape (cotton tape) around the Flat Package IC to protect other parts from any damage. (Refer to Fig. 2-1.)

#### NOTE

Masking is carried out on all the parts located within 10 mm distance from IC leads.

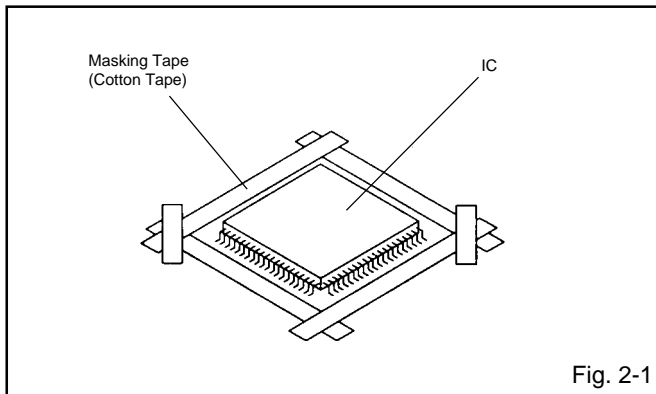

2. Heat the IC leads using a blower type IC desoldering machine. (Refer to Fig. 2-2.)

#### NOTE

Do not rotate or move the IC back and forth, until IC can move back and forth easily after desoldering the leads completely.

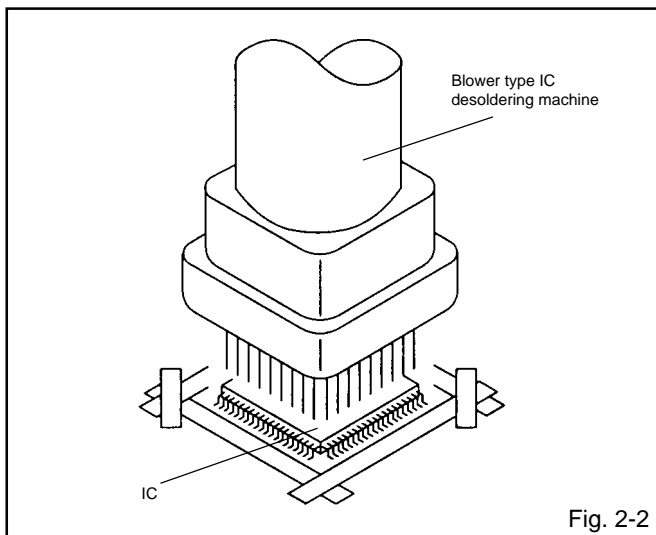

3. When IC starts moving back and forth easily after desoldering completely, pickup the corner of the IC using a tweezers and remove the IC by moving with the IC desoldering machine. (Refer to Fig. 2-3.)

#### NOTE

Some ICs on the PCB are affixed with glue, so be careful not to break or damage the foil of each IC leads or solder lands under the IC when removing it.

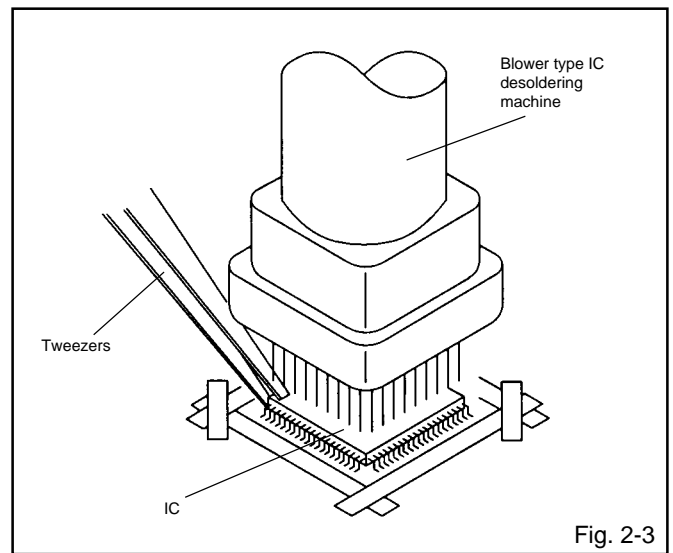

4. Peel off the Masking Tape.

5. Absorb the solder left on the pattern using the Braided Shield Wire. (Refer to Fig. 2-4.)

#### NOTE

Do not move the Braided Shield Wire in the vertical direction towards the IC pattern.

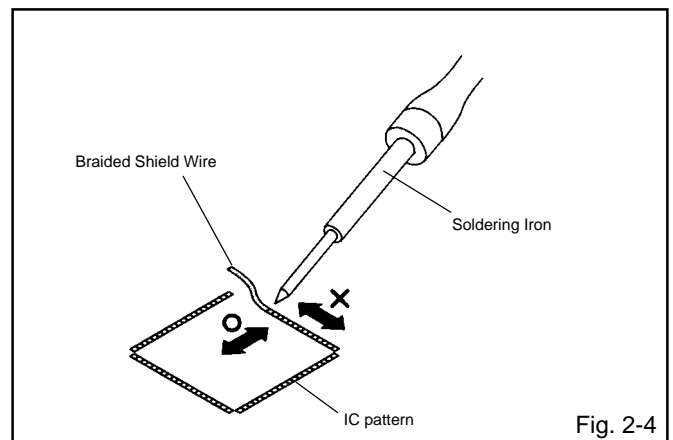

# DISASSEMBLY INSTRUCTIONS

## INSTALLATION

1. Take care of the polarity of new IC and then install the new IC fitting on the printed circuit pattern. Then solder each lead on the diagonal positions of IC temporarily. (Refer to Fig. 2-5.)

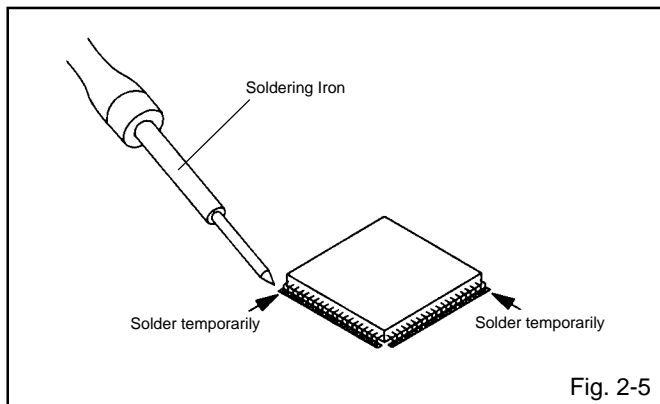

2. Supply the solder from the upper position of IC leads sliding to the lower position of the IC leads. (Refer to Fig. 2-6.)

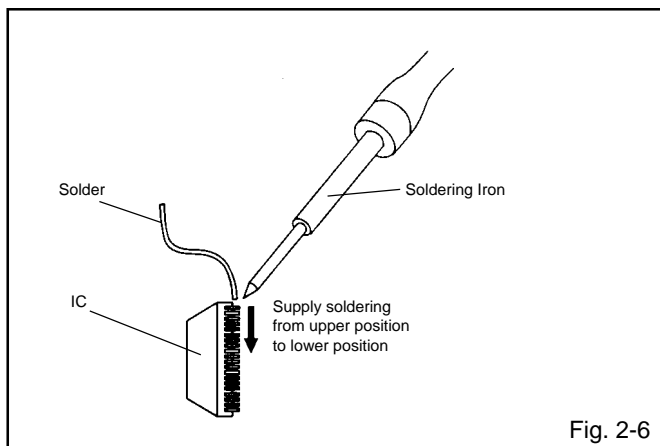

3. Absorb the solder left on the lead using the Braided Shield Wire. (Refer to Fig. 2-7.)

### NOTE

Do not absorb the solder to excess.

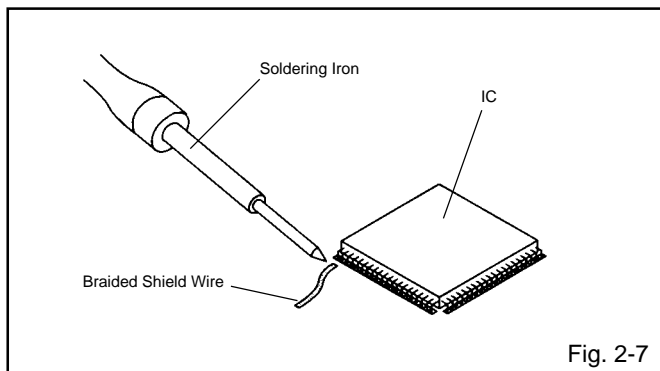

4. When bridge-soldering between terminals and/or the soldering amount are not enough, resolder using a Thin-tip Soldering Iron. (Refer to Fig. 2-8.)

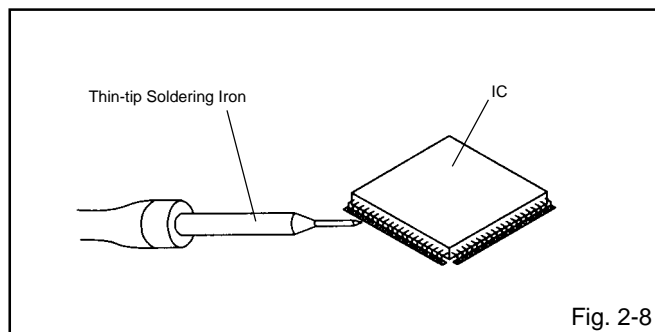

5. Finally, confirm the soldering status on four sides of the IC using a magnifying glass. Confirm that no abnormality is found on the soldering position and installation position of the parts around the IC. If some abnormality is found, correct by resoldering.

### NOTE

When the IC leads are bent during soldering and/or repairing, do not repair the bending of leads. If the bending of leads are repaired, the pattern may be damaged. So, always be sure to replace the IC in this case.

## SERVICE MODE LIST

This unit is provided with the following SERVICE MODES so you can repair, examine and adjust easily. To enter to the Service Mode, press both set key and remote control key for more than 1 second.

Set Key	Remocon Key	Operations
VOL. (-) MIN	0	Releasing of V-CHIP PASSWORD.
VOL. (-) MIN	1	Initialization of factory data. NOTE: Do not use this for the normal servicing. If you set a factory initialization, the memories are reset such as the channel setting, and the POWER ON total hours.
VOL. (-) MIN	6	POWER ON total hours is displayed on the screen. Refer to the "CONFIRMATION OF HOURS USED".  Can be checked of the INITIAL DATA of MEMORY IC. Refer to the "WHEN REPLACING EEPROM (MEMORY) IC".
VOL. (-) MIN	9	Display of the Adjustment MENU on the screen. Refer to the "ELECTRICAL ADJUSTMENT" (On-Screen Display Adjustment).

### CONFIRMATION OF HOURS USED

POWER ON total hours can be checked on the screen. Total hours are displayed in 16 system of notation.

**NOTE: If you set a factory initialization, the total hours is reset to "0".**

1. Set the VOLUME to minimum.
2. Press both VOL. DOWN button on the set and Channel button **(6)** on the remote control for more than 1 second.
3. After the confirmation of using hours, turn off the power.

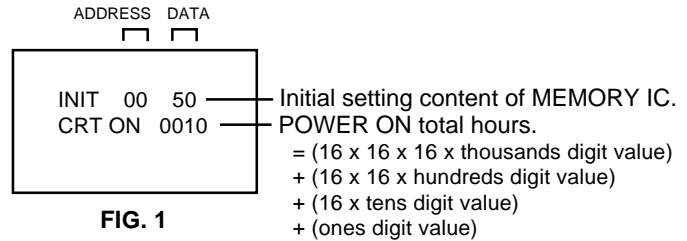

## WHEN REPLACING EEPROM (MEMORY) IC

If a service repair is undertaken where it has been required to change the MEMORY IC, the following steps should be taken to ensure correct data settings while making reference to TABLE 1.

**NOTE: No need setting for after INI 5F due to the adjustment value.**

INI	+0	+1	+2	+3	+4	+5	+6	+7	+8	+9	+A	+B	+C	+D	+E	+F
00	50	E8	0A	45	5E	B3	24	B5	*1	AC	0B	84	40	40	40	7F
10	50	00	00	00	03	00	00	00	3F	0F	0D	E2	94	88	3F	00
20	01	04	07	09	0B	0D	0F	10	11	12	13	14	15	16	17	18
30	18	19	19	1A	1A	1B	1B	1B	1C	1C	1C	1D	1D	1E	1E	1F
40	1F	1F	20	20	20	21	21	21	22	22	23	23	24	24	25	25
50	26	26	27	27	28	28	29	29	2A	2A	2B	2B	2C	2C	2D	2D

\*1

INI	USA	CANADA
08	3B	3A

**Table 1**

1. Enter DATA SET mode by setting VOLUME to minimum.
  2. Press both VOL. DOWN button on the set and Channel button **(6)** on the remote control for more than 1 second. ADDRESS and DATA should appear as FIG 1.
  3. ADDRESS is now selected and should "blink". Using the VOL. UP/DOWN button on the remote, step through the ADDRESS until required ADDRESS to be changed is reached.
  4. Press ENTER to select DATA. When DATA is selected, it will "blink".
  5. Again, step through the DATA using VOL. UP/DOWN button until required DATA value has been selected.
  6. Pressing ENTER will take you back to ADDRESS for further selection if necessary.
  7. Repeat steps 3 to 6 until all data has been checked.
  8. When satisfied correct DATA has been entered, turn POWER off (return to STANDBY MODE) to finish DATA input.  
**After the data input, set to the initializing of shipping.**
  9. Turn POWER on.
  10. Press both VOL. DOWN button on the set and Channel button **(1)** on the remote control for more than 1 second.
  11. After the finishing of the initializing of shipping, the unit will turn off automatically.
- The unit will now have the correct DATA for the new MEMORY IC.

# ELECTRICAL ADJUSTMENTS

## 1. ADJUSTMENT PROCEDURE

Read and perform these adjustments when repairing the circuits or replacing electrical parts or PCB assemblies.

### CAUTION

- Use an isolation transformer when performing any service on this chassis.
- Before removing the anode cap, discharge electricity because it contains high voltage.
- When removing a PCB or related component, after unfastening or changing a wire, be sure to put the wire back in its original position.
- When you exchange IC and Transistor for a heat sink, apply the silicon grease on the contact section of the heat sink. Before applying new silicon grease, remove all the old silicon grease. (Old grease may cause damages to the IC and Transistor.)

Prepare the following measurement tools for electrical adjustments.

1. Oscilloscope
2. Digital Voltmeter
3. Multi-sound Generator
4. Pattern Generator

### On-Screen Display Adjustment

1. In the condition of NO indication on the screen. Press the VOL. DOWN button on the set and the Channel button (9) on the remote control for more than 1 second to appear the adjustment mode on the screen as shown in Fig. 1-1.

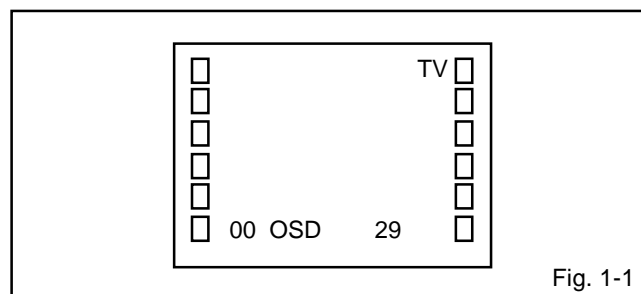

Fig. 1-1

2. Use the Channel UP/DOWN button or Channel button (0-9) on the remote control to select the options shown in Fig. 1-2.
3. Press the MENU button on the remote control to end the adjustments.

NO.	FUNCTION	NO.	FUNCTION
00	OSD H	18	CONTRAST MAX
01	CUT OFF	19	CONTRAST CENT
02	H. VCO	20	CONTRAST MIN
03	H. PHASE	21	COLOR MAX
04	AFC GAIN	22	COLOR CENTER
05	V. SHIFT	23	COLOR MIN
06	H. SIZE	24	TINT
07	V. SIZE	25	SHARPNESS
08	V. LINERITY	26	CB DL
09	VS CORRECTION	27	CR DL
10	R DRIVE	28	CB PED
11	B DRIVE	29	CR PED
12	R CUT OFF	30	PARABOLA
13	G CUT OFF	31	CORNER
14	B CUT OFF	32	TRAPWZIUM
15	BRIGHT MAX	33	LEVEL
16	BRIGHT CENT	34	SEPARATION1
17	BRIGHT MIN	35	SEPARATION2

Fig. 1-2

## 2. BASIC ADJUSTMENTS

### 2-1: CONSTANT VOLTAGE

1. Set condition is AV MODE without signal.
2. Connect the digital voltmeter to the TP003.
3. Adjust the VR502 until the digital voltmeter is  $115 \pm 0.5V$ .

### 2-2: CUT OFF

1. Place the set with Aging Test for more than 15 minutes.
2. Set condition is AV MODE without signal.
3. Using the remote control, set the brightness and contrast to normal position.
4. Activate the adjustment mode display of Fig. 1-1 and press the channel button (01) on the remote control to select "CUT OFF".
5. Adjust the Screen Volume until a dim raster is obtained.

### 2-3: WHITE BALANCE, WHITE BALANCE CS

NOTE: Adjust after performing CUT OFF adjustment.

1. Place the set with Aging Test for more than 15 minutes.
2. Receive the gray scale pattern from the Pattern Generator with Brust On.
3. Using the remote control, set the brightness and contrast to normal position.
4. Activate the adjustment mode display of Fig. 1-1 and press the channel button (12) on the remote control to select "R. BIAS".
5. Press the CH. UP/DOWN button on the remote control to select the "R. BIAS", "G. BIAS", "B. BIAS", "B. DRIVE" or "R. DRIVE".
6. Adjust the VOL. UP/DOWN button on the remote control to whiten the R. BIAS, G. BIAS, B. BIAS, B. DRIVE and R. DRIVE at each step tone sections equally.
7. Perform the above adjustments 5 and 6 until the white color is looked like a white.
8. Press the TV/VIDEO button on the remote control to set to the CS mode.
9. Receive the gray scale pattern from the Pattern Generator with Brust On.
10. If the picture is too much green. Activate the adjustment mode display of Fig. 1-1 and press the channel button (28) on the remote control to select "CB PED".
11. Adjust the VOL. UP/DOWN button on the remote control to select the step up.
12. If the picture is too much red. Activate the adjustment mode display of Fig. 1-1 and press the channel button (29) on the remote control to select "CR PED".
13. Adjust the VOL. UP/DOWN button on the remote control to select the step down.

### 2-4: FOCUS

1. Receive the monoscope pattern.
2. Turn the Focus Volume fully counterclockwise once.
3. Adjust the Focus Volume until picture is distinct.

# ELECTRICAL ADJUSTMENTS

## 2-5: VERTICAL POSITION

1. Receive the monoscope pattern.
2. Using the remote control, set the brightness and contrast to normal position.
3. Adjust the **VR401** until the horizontal line becomes fit to the notch of the shadow mask.

## 2-6: VERTICAL SIZE

1. Receive the monoscope pattern.
2. Using the remote control, set the brightness and contrast to normal position.
3. Activate the adjustment mode display of **Fig. 1-1** and press the channel button (**07**) on the remote control to select "V. SIZE".
4. Press the VOL. UP/DOWN button on the remote control until the SHIFT quantity of the OVER SCAN on upside and downside becomes  $9 \pm 2\%$ .

## 2-7: VERTICAL LINEARITY

**NOTE:** Adjust after performing adjustments in section 2-6. After the adjustment of Vertical Linearity, reconfirm the Vertical Position and Vertical Size adjustments.

1. Receive the monoscope pattern.
2. Using the remote control, set the brightness, contrast, to normal position.
3. Activate the adjustment mode display of **Fig. 1-1** and press the channel button (**08**) on the remote control to select "V. LINEARITY".
4. Press the VOL. UP/DOWN button on the remote control until the SHIFT quantity of the OVER SCAN on upside and downside becomes minimum.

## 2-8: LEVEL

1. Connect the AC voltmeter to **pin 6 of CP101**.
2. Activate the adjustment mode display of **Fig. 1-1** and press the channel button (**33**) on the remote control to select "LEVEL".
3. Press the VOL. UP/DOWN button on the remote control until the AC voltmeter is  $90 \pm 2mV$ .

## 2-9: HORIZONTAL PHASE

1. Receive the monoscope pattern.
2. Using the remote control, set the brightness and contrast to normal position.
3. Activate the adjustment mode display of **Fig. 1-1** and press the channel button (**03**) on the remote control to select "H.PHASE".
4. Press the VOL. UP/DOWN button on the remote control until the SHIFT quantity of the OVER SCAN on right and left becomes minimum.

## 2-10: CONTRAST MAX

1. Activate the adjustment mode display of **Fig. 1-1** and press the channel button (**18**) on the remote control to select "CONT. MAX".
2. Press the VOL. UP/DOWN button on the remote control until the contrast step No. becomes "95".
3. Receive a broadcast and check if the picture is normal.
4. Press the TV/VIDEO button on the remote control to set to the AV mode. Then perform the above adjustments 1~3.
5. Press the TV/VIDEO button on the remote control to set to the CS mode. Then perform the above adjustments 1~3.

## 2-11: SEPARATION 1, 2

Please do the method (1) or method (2) adjustment.

### Method (1)

1. Set the multi-sound signal generator for each different L-ch and R-ch frequency (Ex. L-ch=2KHz, R-ch=400Hz) and receive the RF.
2. Connect the oscilloscope to the **pin 6 and pin 7 of CP101**.
3. Activate the adjustment mode display of **Fig. 1-1** and press the channel button (**34**) on the remote control to select "SEP 1".
4. Press the VOL. UP/DOWN button on the remote control to adjust it until the audio output wave becomes a fine sine wave.
5. Press the CH UP button once the set to "SEP 2" mode. Then perform the above adjustment 4.

### Method (2)

1. Set the multi-sound signal generator L-ch=1KHz, R-ch=Non input and receive the RF.
2. Connect the oscilloscope to the **pin 6 of CP101**.
3. Press the AUDIO SELECT button on the remote control to set to the stereo mode.
4. Activate the adjustment mode display of **Fig. 1-1** and press the channel button (**34**) on the remote control to select "SEP 1".
5. Press the VOL. UP/DOWN button on the remote control to adjust it until the R-ch output becomes minimum.
6. Set the multi-sound signal generator L-ch=Non input, R-ch=1KHz and receive the RF.
7. Connect the oscilloscope to the pin 7 of CP101.
8. Activate the adjustment mode display of **Fig. 1-1** and press the channel button (**35**) on the remote control to select "SEP 2".
9. Press the VOL. UP/DOWN button on the remote control to adjust it until the L-ch output becomes minimum. The output difference of the between with Filter and without Filter should be more than 25db for both L and R.

## 2-12: OSD POSITION

1. Activate the adjustment mode display of **Fig. 1-1**.
2. Press the VOL. UP/DOWN button on the remote control until the difference of A and B becomes minimum. (**Refer to Fig. 2-1**)

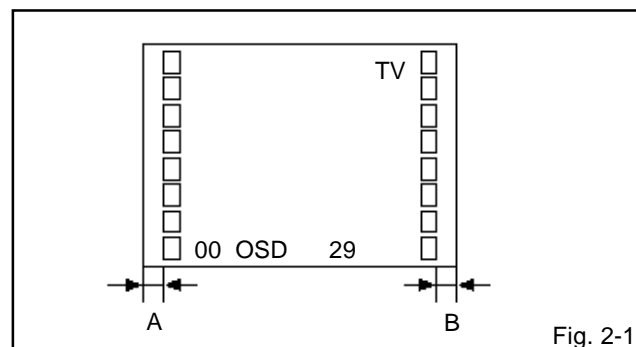

Fig. 2-1

# ELECTRICAL ADJUSTMENTS

## 2-13: BRIGHT CENT

1. Receive the monoscope pattern. (RF Input)
2. Using the remote control, set the brightness and contrast to normal position.
3. Activate the adjustment mode display of **Fig. 1-1** and press the channel button **(16)** on the remote control to select "BRI CENT".
4. Press the VOL. UP/DOWN button on the remote control until the white 10% is starting to be visible.
5. Receive the monoscope pattern. (Audio Video Input)
6. Press the TV/VIDEO button on the remote control to set to the AV mode. Then perform the above adjustments 2~4.
7. Press the TV/VIDEO button on the remote control to set to the CS mode.
8. Activate the adjustment mode display of **Fig. 1-1** and press the channel button **(16)** on the remote control to select "BRI CENT".
9. Press the VOL. UP/DOWN button on the remote control until the brightness step No. becomes "80".

## 2-14: COLOR CENT

1. Receive the color bar pattern. (RF Input)
2. Using the remote control, set the brightness, contrast, color and tint to normal position.
3. Connect the oscilloscope to **TP022**.
4. Activate the adjustment mode display of **Fig. 1-1** and press the channel button **(22)** on the remote control to select "COL. CENT".
5. Adjust the VOLTS RANGE VARIABLE knob of the oscilloscope until the range between white 100% and 0% is set to 4 scales on the screen of the oscilloscope.
6. Press the VOL. UP/DOWN button on the remote control until the red color level is adjusted to  $120 \pm 5\%$  of the white level. **(Refer to Fig. 2-2)**
7. Receive the video color bar pattern. (Audio Video Input)
8. Set to the AV mode. Then perform the above adjustments 2~6.
9. Press the TV/VIDEO button on the remote control to set to the CS mode. Then perform the above adjustments 2~4.
10. Press the VOL. UP/DOWN button on the remote control until the color step No. becomes "66".

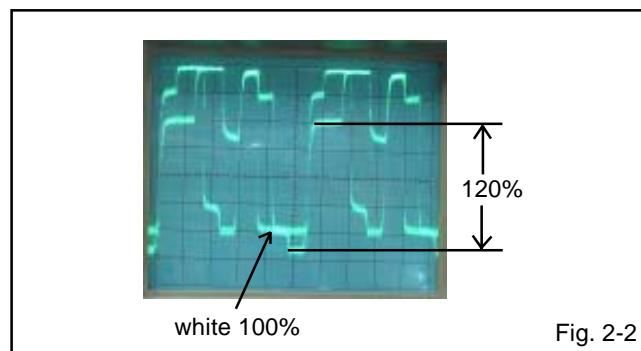

## 2-15: TINT

1. Receive the color bar pattern. (RF Input)
2. Using the remote control, set the brightness, contrast, color and tint to normal position.
3. Connect the oscilloscope to **TP024**.
4. Activate the adjustment mode display of **Fig. 1-1** and press the channel button **(24)** on the remote control to select "TINT".
5. Press the VOL. UP/DOWN button on the remote control until the section "A" becomes as straight line. **(Refer to Fig. 2-3)**
6. Receive the video color bar pattern. (Audio Video Input)
7. Set to the AV mode. Then perform the above adjustments 2~5.
8. Press the TV/VIDEO button on the remote control to set to the CS mode. Then perform the above adjustments 2~4.
9. Press the VOL. UP/DOWN button on the remote control until the tint step No. becomes "52".

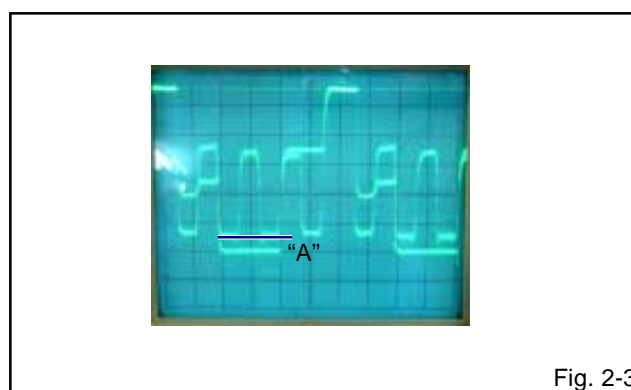

## 2-16: Confirmation of Fixed Value (Step No.)

Please check if the fixed values of the each adjustment items are set correctly referring below.

NO.	FUNCTION	RF	AV	CS
02	H.VCO	03	03	03
04	AFC GAIN	07	07	07
05	V.SHIFT	02	02	02
06	H.SIZE	01	01	01
09	VS CORRECTION	34	34	34
15	BRI.MAX	125	125	125
17	BRI.MIN	75	75	75
19	CONT.CENT	50	50	50
20	CONT.MIN	18	18	18
21	COL.MAX	90	90	90
23	COL.MIN	00	00	00
25	SHARPNESS	40	40	40
26	CB DL	00	00	00
27	CR DL	00	00	00
30	PARABOLA	31	31	31
31	CORNER	31	31	31
32	TRAPEZIUM	31	31	31

# ELECTRICAL ADJUSTMENTS

## 3. PURITY AND CONVERGENCE ADJUSTMENTS

### NOTE

1. Turn the unit on and let it warm up for at least 30 minutes before performing the following adjustments.
2. Place the CRT surface facing east or west to reduce the terrestrial magnetism.
3. Turn ON the unit and demagnetize with a Degauss Coil.

### 3-1: STATIC CONVERGENCE (ROUGH ADJUSTMENT)

1. Tighten the screw for the magnet. Refer to the adjusted CRT for the position. **(Refer to Fig. 3-1)**  
If the deflection yoke and magnet are in one body, untighten the screw for the body.
2. Receive the green raster pattern from the color bar generator.
3. Slide the deflection yoke until it touches the funnel side of the CRT.
4. Adjust center of screen to green, with red and blue on the sides, using the pair of purity magnets.
5. Switch the color bar generator from the green raster pattern to the crosshatch pattern.
6. Combine red and blue of the 3 color crosshatch pattern on the center of the screen by adjusting the pair of 4 pole magnets.
7. Combine red/blue (magenta) and green by adjusting the pair of 6 pole magnets.
8. Adjust the crosshatch pattern to change to white by repeating steps 6 and 7.

### 3-2: PURITY

#### NOTE

Adjust after performing adjustments in section 3-1.

1. Receive the green raster pattern from color bar generator.
2. Adjust the pair of purity magnets to center the color on the screen.  
Adjust the pair of purity magnets so the color at the ends are equally wide.
3. Move the deflection yoke backward (to neck side) slowly, and stop it at the position when the whole screen is green.
4. Confirm red and blue color.  
Adjust the slant of the deflection yoke while watching the screen, then tighten the fixing screw.

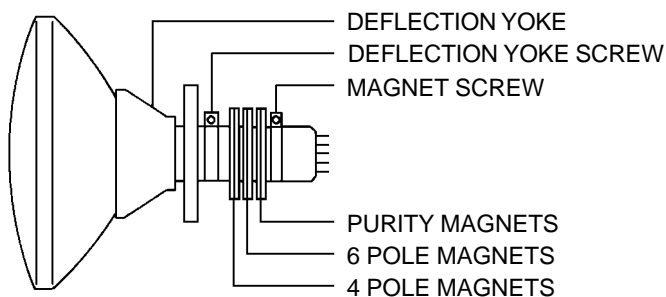

Fig. 3-1

### 3-3: STATIC CONVERGENCE

#### NOTE

Adjust after performing adjustments in section 3-2.

1. Receive the crosshatch pattern from the color bar generator.
2. Combine red and blue of the 3 color crosshatch pattern on the center of the screen by adjusting the pair of 4 pole magnets.
3. Combine red/blue (magenta) and green by adjusting the pair of 6 pole magnets.

### 3-4: DYNAMIC CONVERGENCE

#### NOTE

Adjust after performing adjustments in section 3-3.

1. Adjust the differences around the screen by moving the deflection yoke upward/downward and right/left. (Refer to Fig. 3-2-a)
2. Insert three wedges between the deflection yoke and CRT funnel to fix the deflection yoke. (Refer to Fig. 3-2-b)

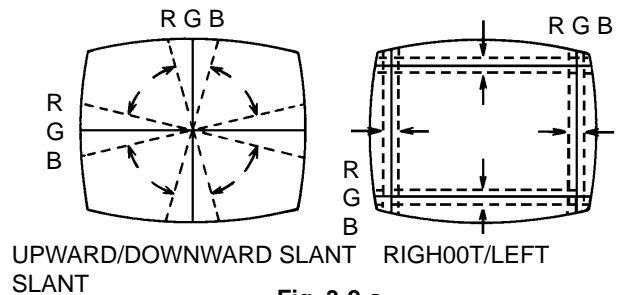

# ELECTRICAL ADJUSTMENTS

## 4. ELECTRICAL ADJUSTMENT PARTS LOCATION GUIDE (WIRING CONNECTION)

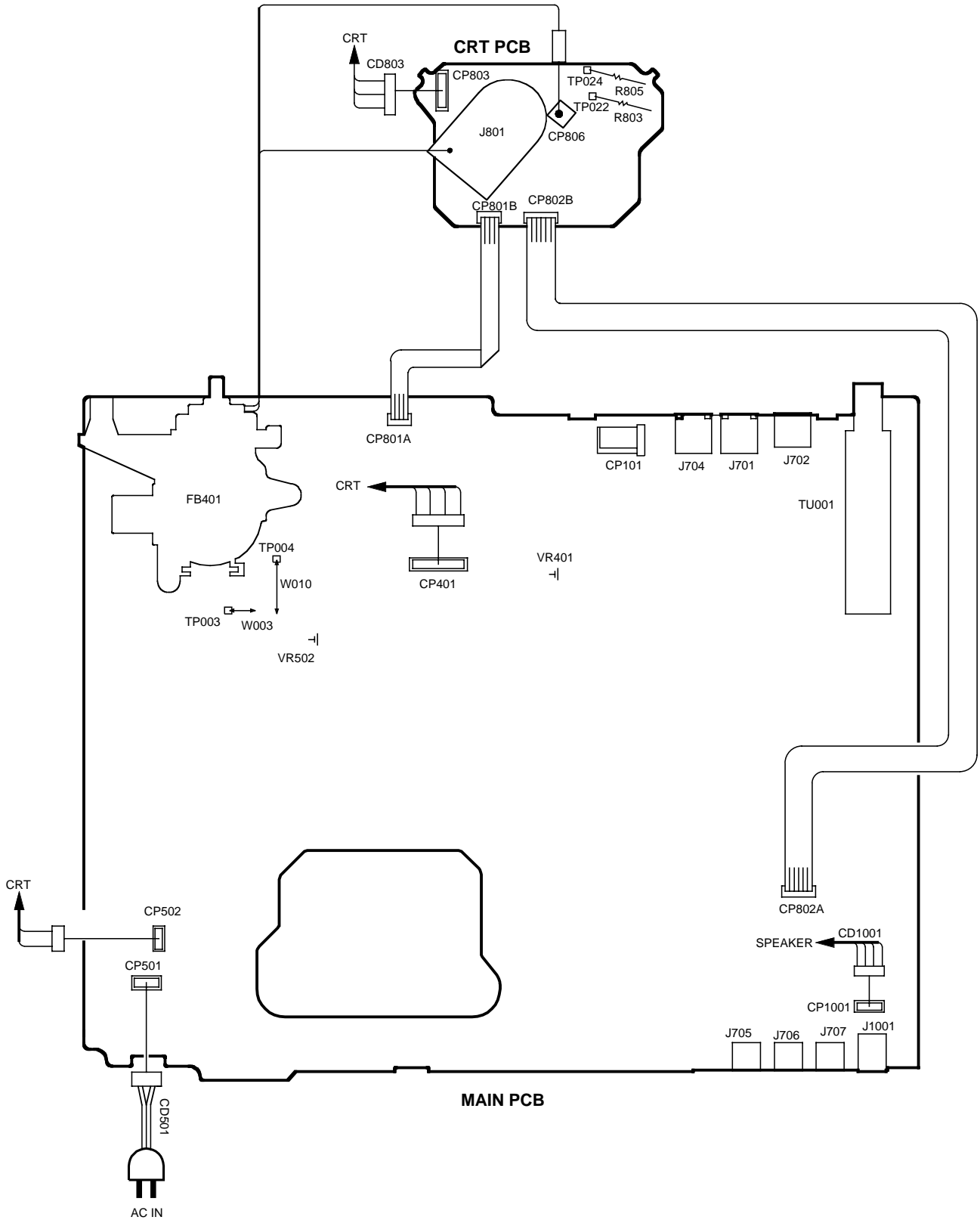

### BLOCK DIAGRAM

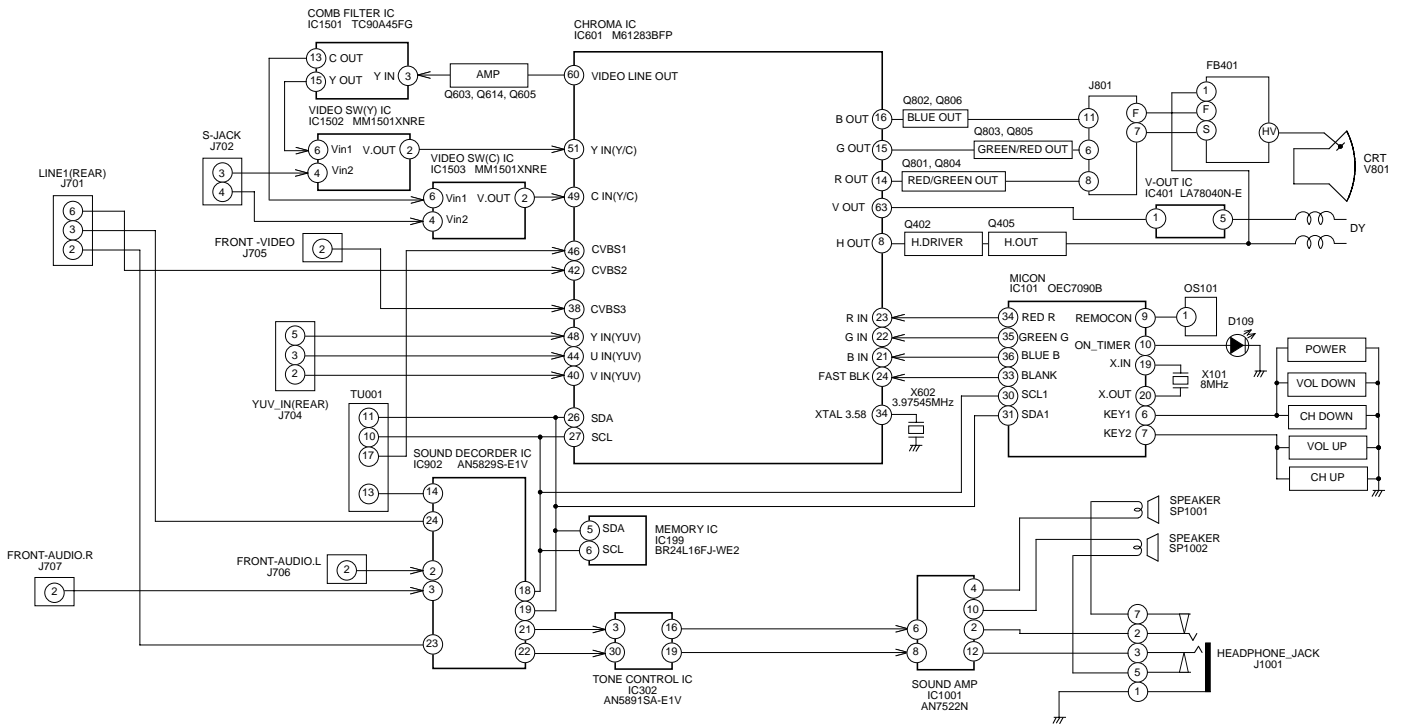



PRINTED CIRCUIT BOARDS  
MAIN/CRT (CHIP MOUNTED PARTS)  
SOLDER SIDE

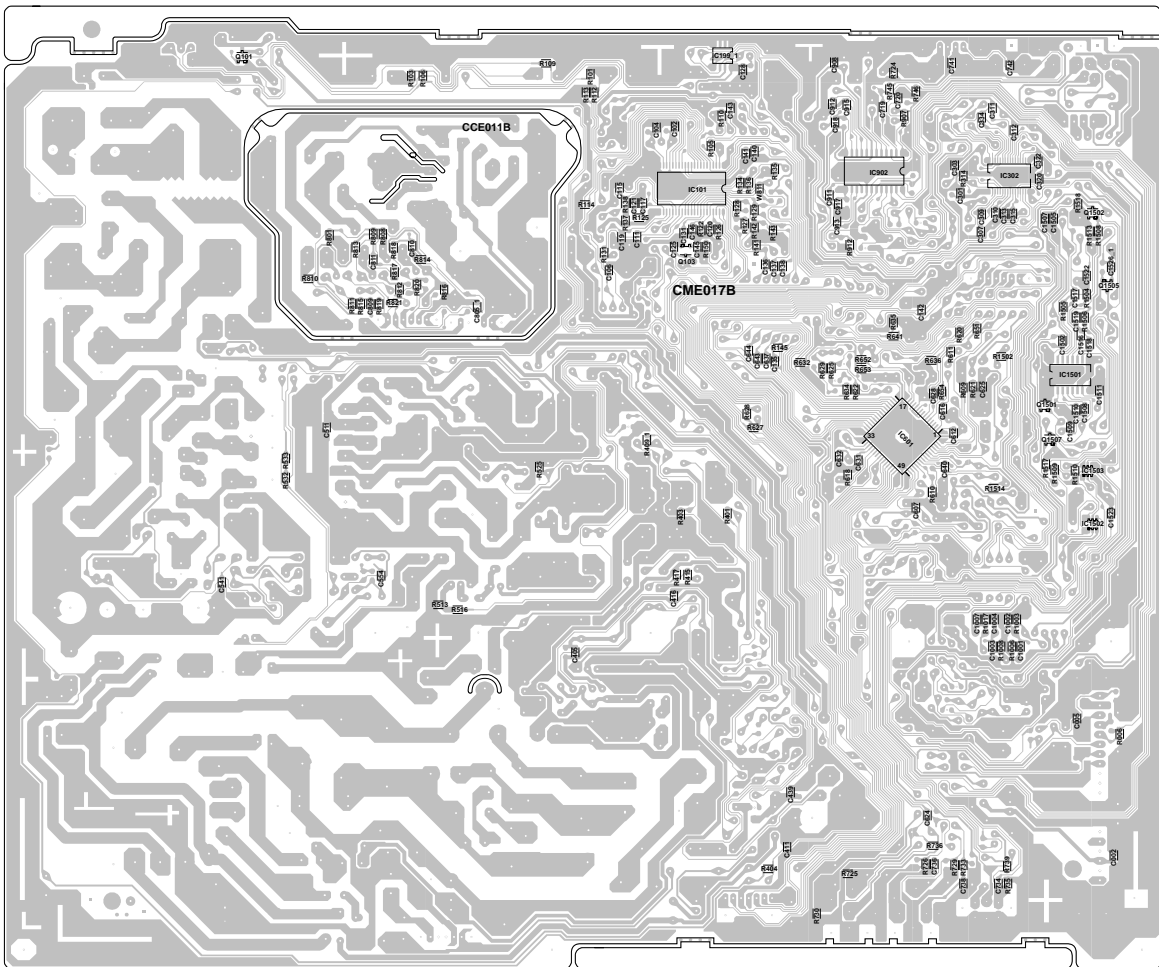

# MICON SCHEMATIC DIAGRAM (MAIN PCB)

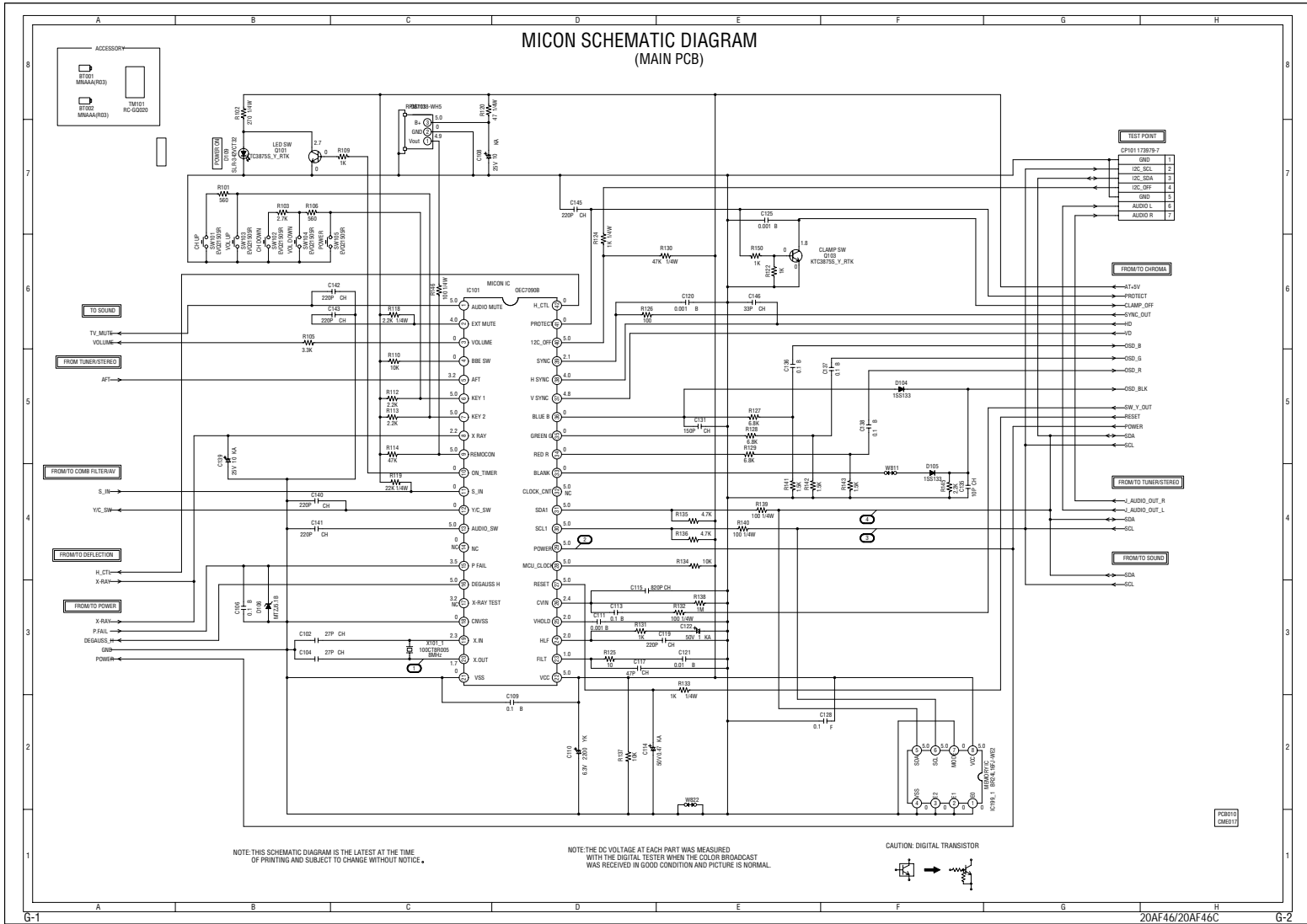



## DEFLECTION SCHEMATIC DIAGRAM (MAIN PCB)

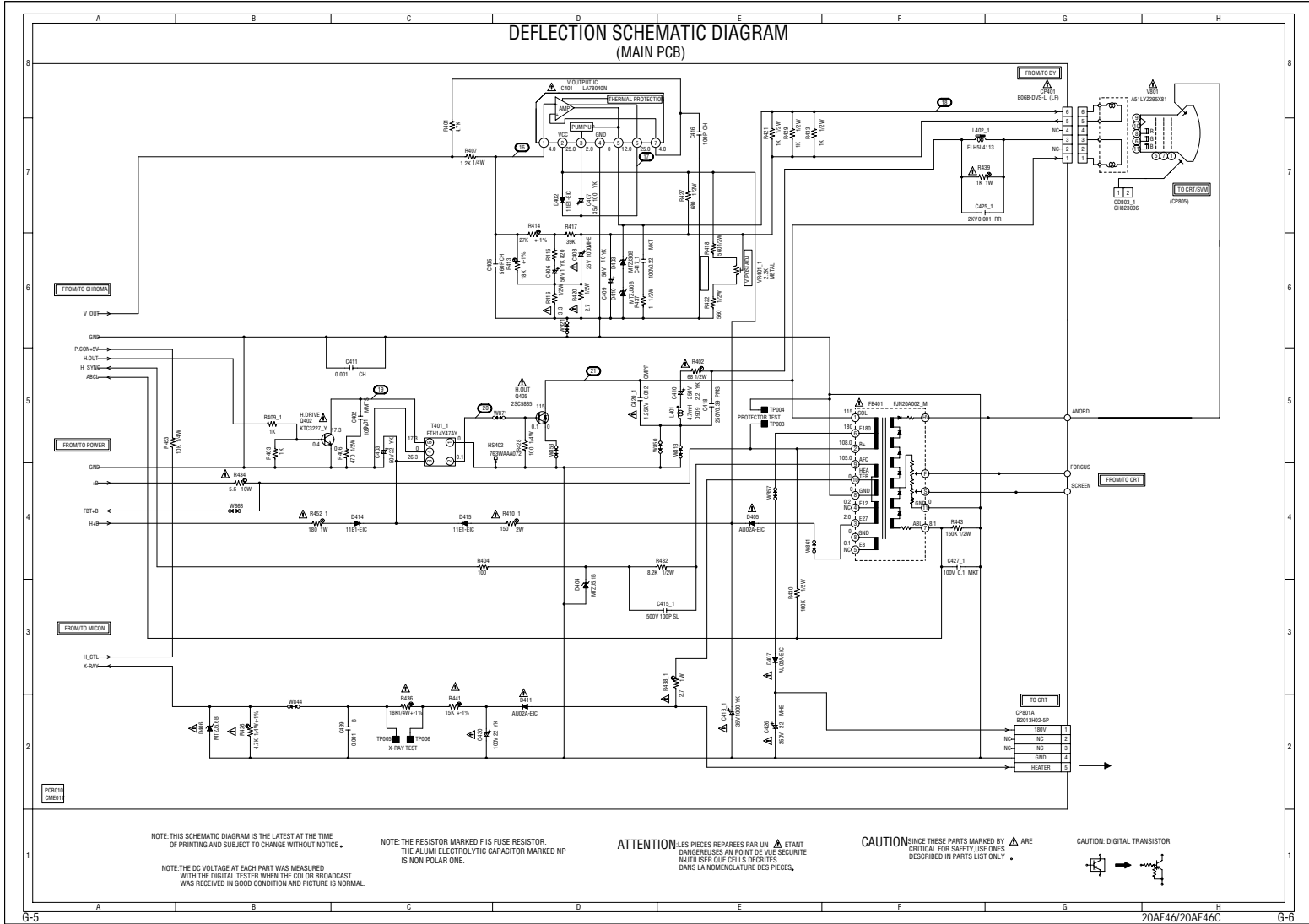

NOTE: THIS SCHEMATIC DIAGRAM IS THE LATEST AT THE TIME OF PRINTING AND SUBJECT TO CHANGE WITHOUT NOTICE.

NOTE: THE DC VOLTAGE AT EACH PART WAS MEASURED WITH THE DIGITAL TESTER WHEN THE COLOR BROADCAST WAS RECEIVED IN GOOD CONDITION AND PICTURE IS NORMAL.

NOTE: THE RESISTOR MARKED F IS FUSE RESISTOR. THE ALUMI ELECTROLYTIC CAPACITOR MARKED NP IS NON POLAR ONE.

**ATTENTION** LES PIÈCES RÉPARÉES PAR UN  $\Delta$  ÉTANT DANGEREUSES AN POINT DE VUE SÉCURITÉ N'UTILISER QUE CELLES DÉCRITES DANS LA NOMÉCLATURE DES PIÈCES.

**CAUTION** SINCE THESE PARTS MARKED BY  $\Delta$  ARE CRITICAL FOR SAFETY USE ONES DESCRIBED IN PARTS LIST ONLY.

**CAUTION** DIGITAL TESTER

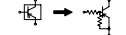



# SOUND SCHEMATIC DIAGRAM (MAIN PCB)

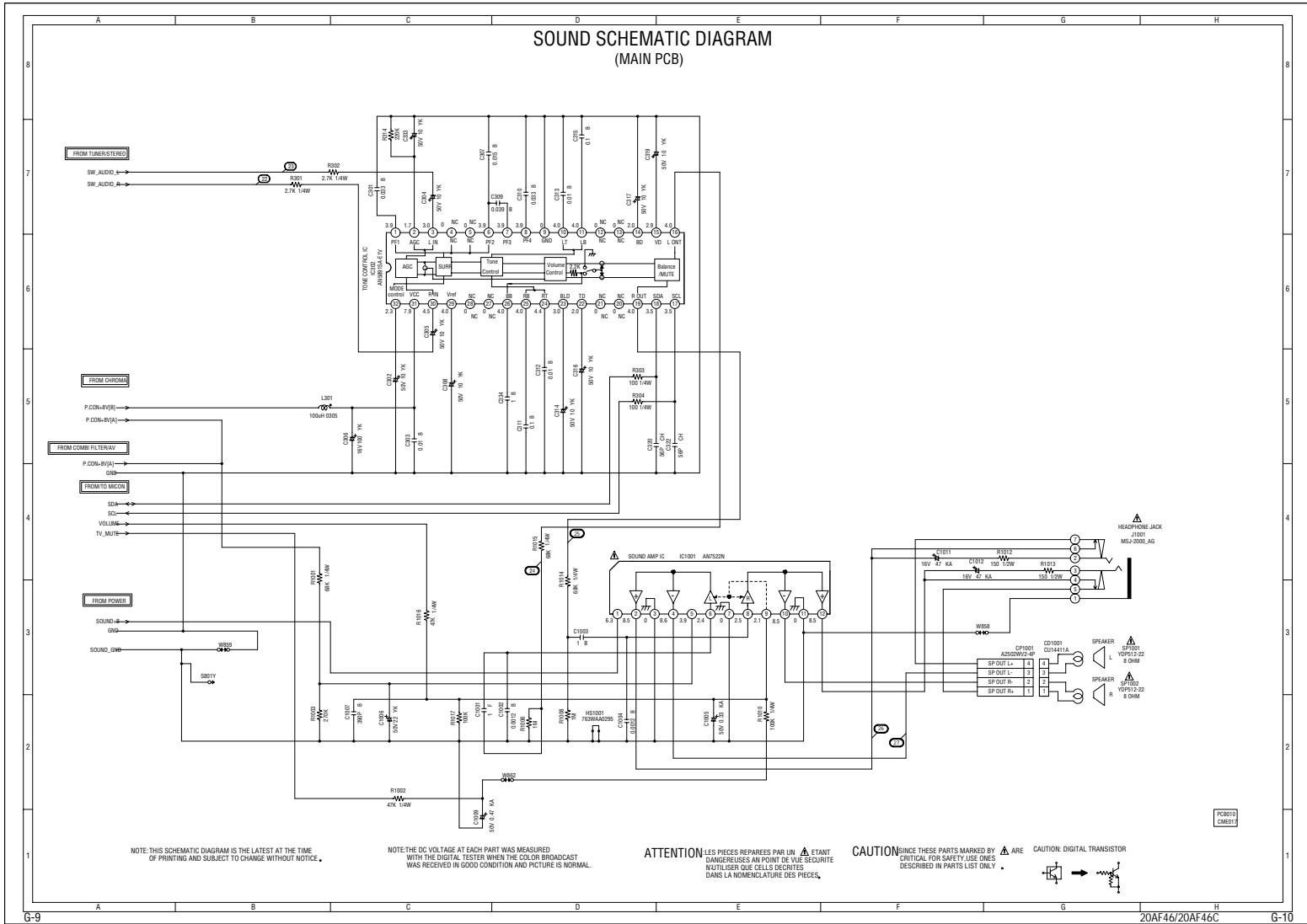

NOTE: THIS SCHEMATIC DIAGRAM IS THE LATEST AT THE TIME OF PRINTING AND SUBJECT TO CHANGE WITHOUT NOTICE.

NOTE: THE DC VOLTAGE AT EACH PART WAS MEASURED WITH THE DIGITAL TESTER WHEN THE COLOR BROADCAST WAS RECEIVED IN GOOD CONDITION AND PICTURE IS NORMAL.

**ATTENTION** - LES PIÈCES RÉPARÉES PAR UN **Δ** ÉTANT DANGEREUSES AN POINT DE VUE SÉCURITÉ, NE PAS LES UTILISER QUE CELLES DÉCRITES DANS LA NOMENCLATURE DES PIÈCES.

**CAUTION** - SINCE THESE PARTS MARKED BY **Δ** ARE CRITICAL FOR SAFETY, USE ONES DESCRIBED IN PARTS LIST ONLY.

CAUTION: DIGITAL TRANSISTOR

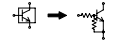

PCB010  
CME017



# COMB FILTER/AV SCHEMATIC DIAGRAM (MAIN PCB)

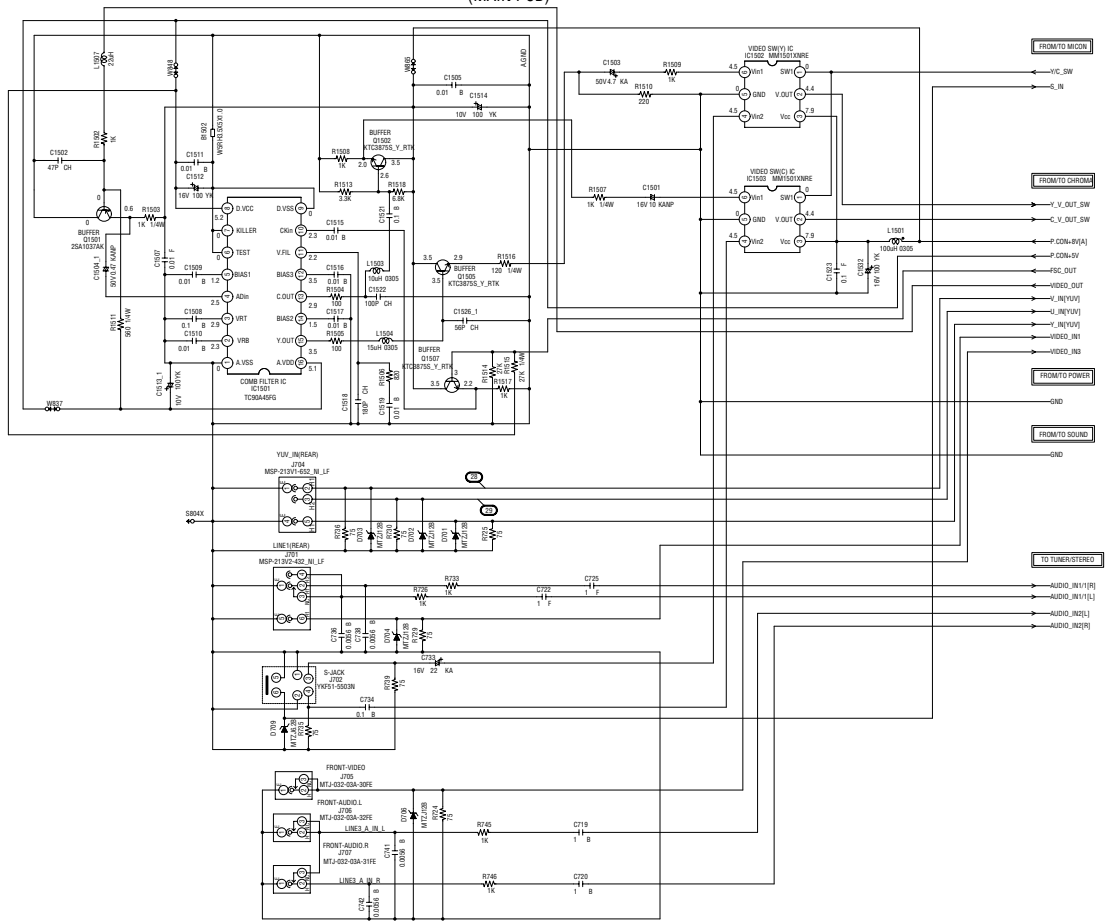

NOTE: THIS SCHEMATIC DIAGRAM IS THE LATEST AT THE TIME OF PRINTING AND SUBJECT TO CHANGE WITHOUT NOTICE.

NOTE: THE DC VOLTAGE AT EACH PART WAS MEASURED WITH THE DIGITAL TESTER WHEN THE COLOR BROADCAST WAS RECEIVED IN GOOD CONDITION AND PICTURE IS NORMAL.

PCB10  
CMB17

# CRT SCHEMATIC DIAGRAM (CRT PCB)

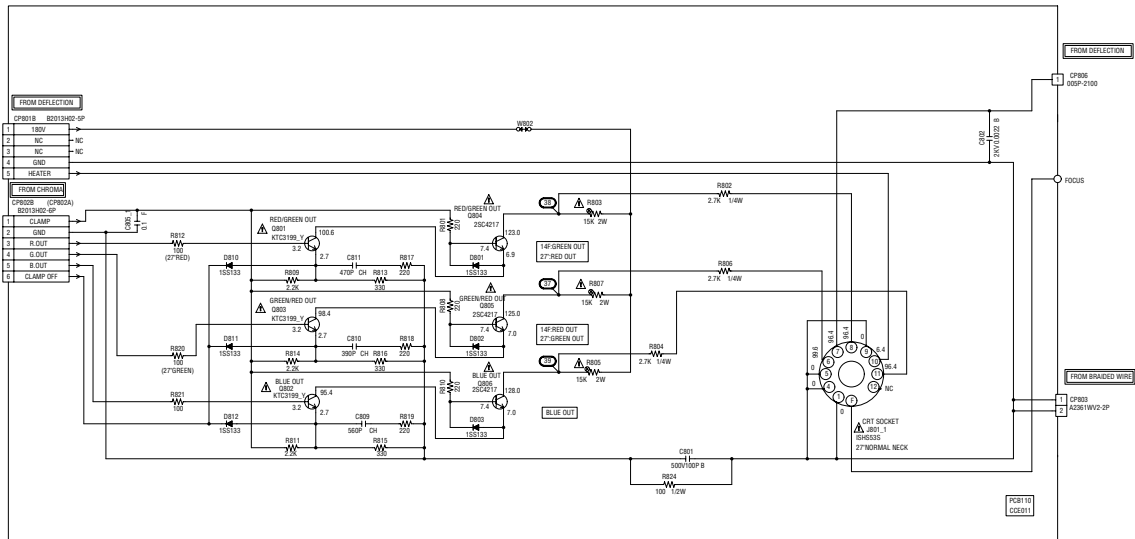

NOTE: THE DC VOLTAGE AT EACH PART WAS MEASURED WITH THE DIGITAL TESTER WHEN THE COLOR BROADCAST WAS RECEIVED IN GOOD CONDITION AND PICTURE IS NORMAL.

NOTE: THIS SCHEMATIC DIAGRAM IS THE LATEST AT THE TIME OF PRINTING AND SUBJECT TO CHANGE WITHOUT NOTICE.

CAUTION: SINCE THESE PARTS MARKED BY ARE CRITICAL FOR SAFETY USE ONES DESCRIBED IN PARTS LIST ONLY.

ATTENTION: LES PIÈCES RÉPARÉES PAR UN ÉTANT DANGEREUSES AU POINT DE VUE SÉCURITÉ N'UTILISER QUE CELLES DÉCRITES DANS LA NOMENCLATURE DES PIÈCES.

# WAVEFORMS

## MICON

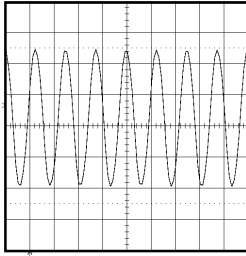

① 1V 0.1 $\mu$ s/div

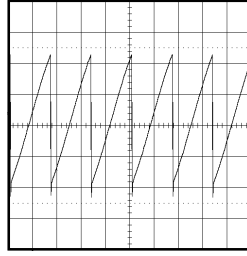

⑧ 0.5V 10ms/div

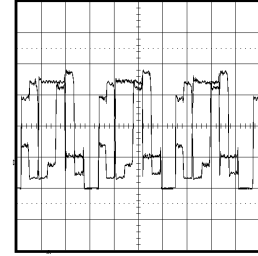

⑬ 1V 20 $\mu$ s/div

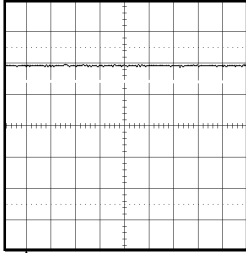

② 1V 1 $\mu$ s/div

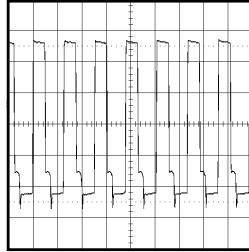

⑨ 1V 50 $\mu$ s/div

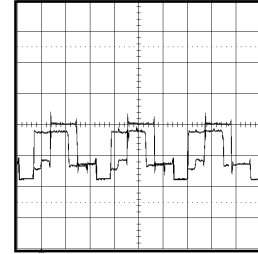

⑭ 2V 20 $\mu$ s/div

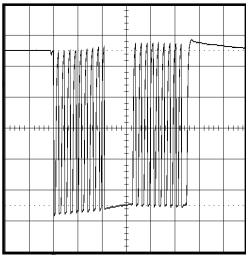

③ 1V 50 $\mu$ s/div

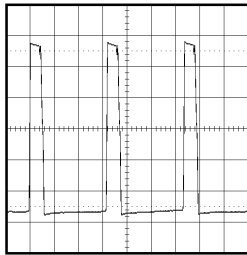

⑩ 2V 20 $\mu$ s/div

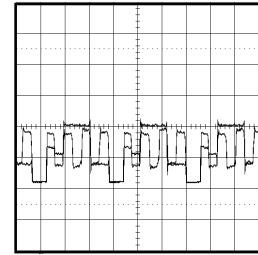

⑮ 2V 20 $\mu$ s/div

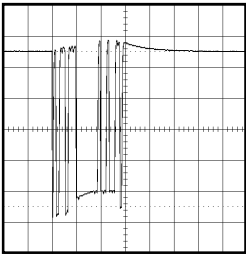

④ 1V 0.1ms/div

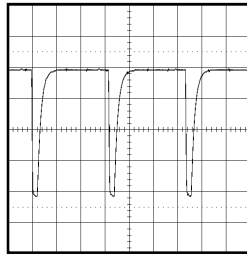

⑪ 0.5V 20 $\mu$ s/div

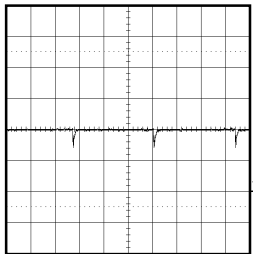

⑯ 2V 5ms/div

## CHROMA

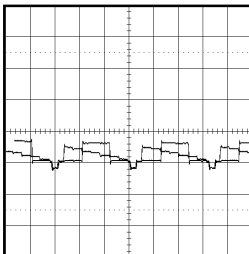

⑦ 1V 20 $\mu$ s/div

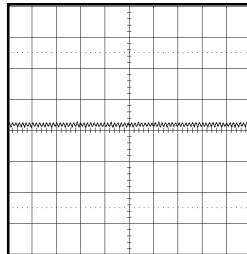

⑫ 1V 2 $\mu$ s/div

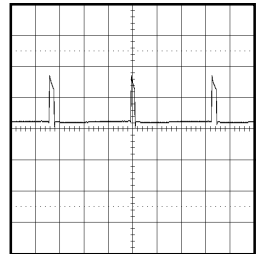

⑰ 20V 5ms/div

**NOTE:** The following waveforms were measured at the point of the corresponding balloon number in the schematic diagram.

## WAVEFORMS

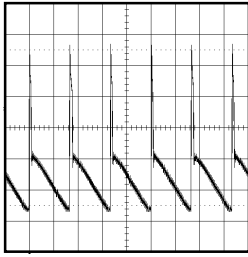

⑱ 10V 10ms/div

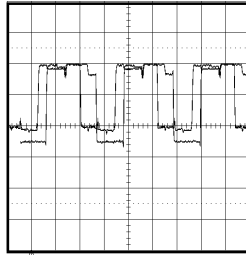

⑳ 50V 20 $\mu$ s/div

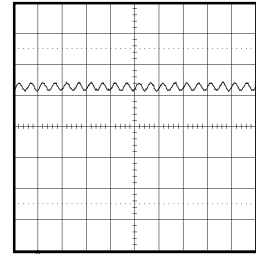

㉑ 2V 5ms/div

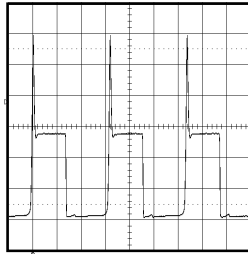

㉒ 20V 20 $\mu$ s/div

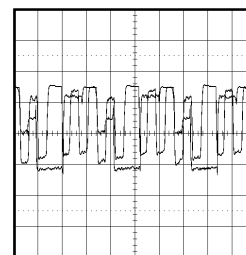

㉓ 50V 20 $\mu$ s/div

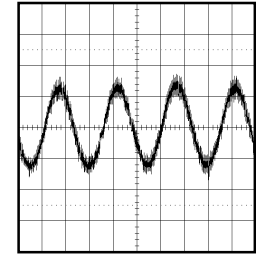

㉔ 0.5V 1ms/div

## SOUND

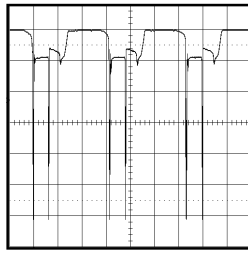

㉕ 2V 20 $\mu$ s/div

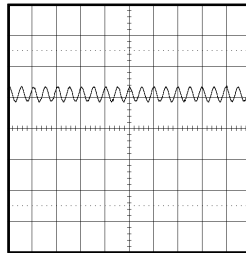

㉖ 2V 5ms/div

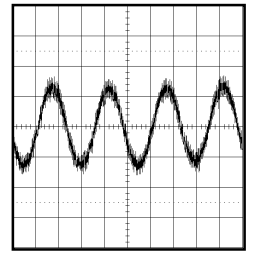

㉗ 0.5V 1ms/div

## COMB FILTER/AV

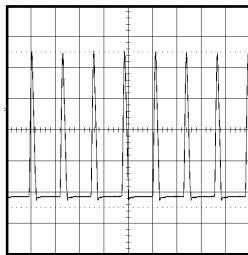

㉘ 200V 50 $\mu$ s/div

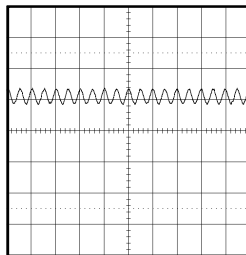

㉙ 2V 5ms/div

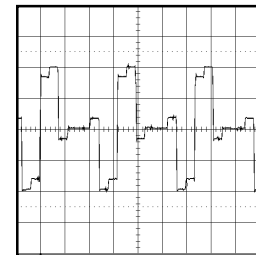

㉚ 200mV 20 $\mu$ s/div

## CRT

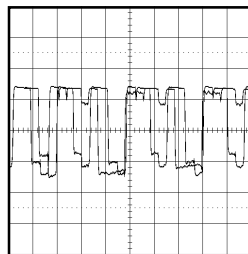

㉛ 50V 20 $\mu$ s/div

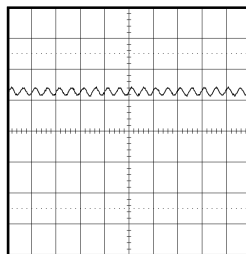

㉜ 2V 5ms/div

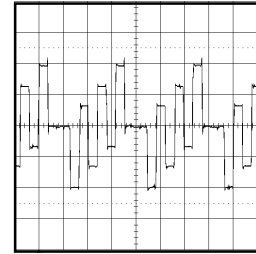

㉝ 200mV 20 $\mu$ s/div

**NOTE:** The following waveforms were measured at the point of the corresponding balloon number in the schematic diagram.

# MECHANICAL EXPLODED VIEW

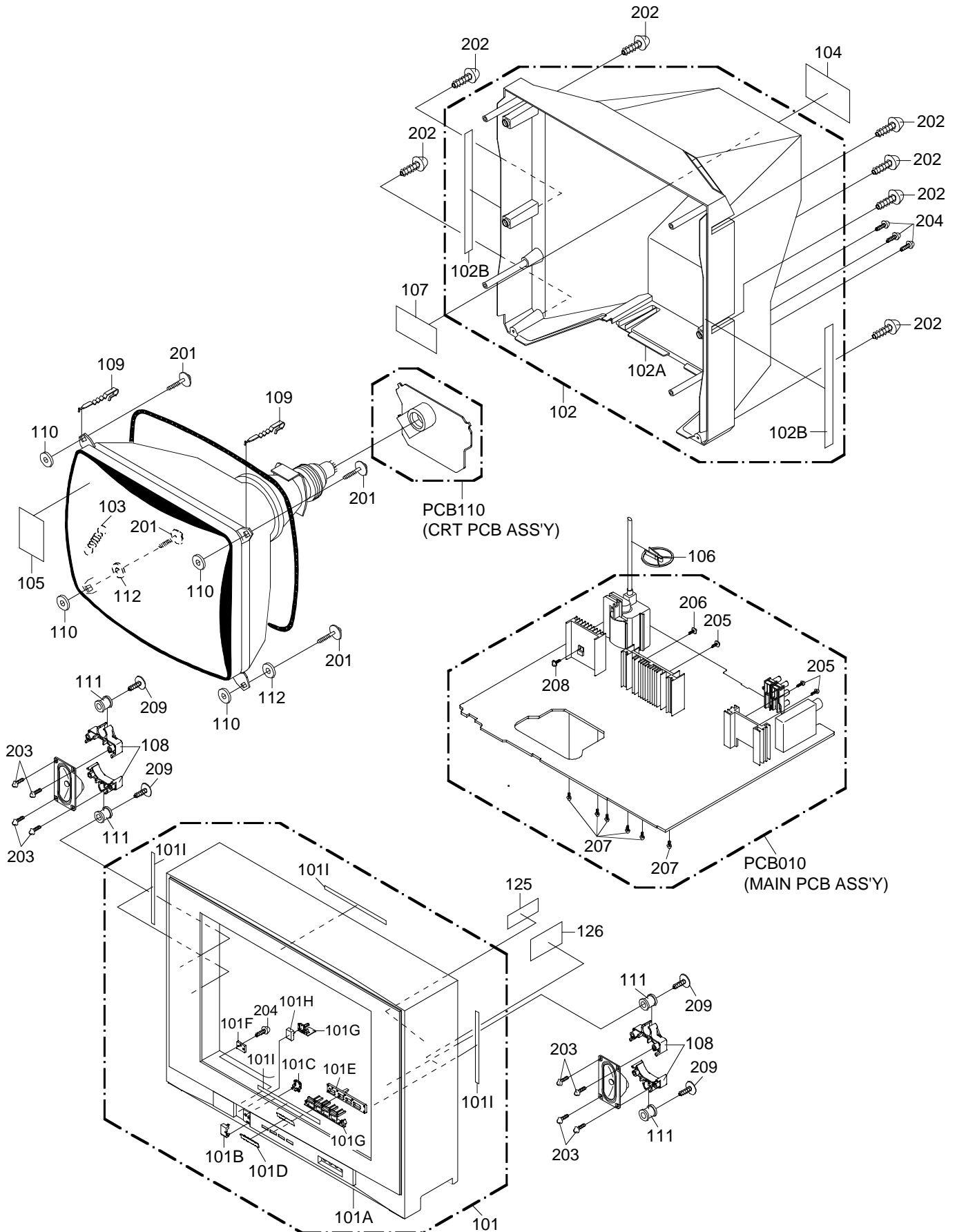

# MECHANICAL EXPLODED VIEW (PACKING DIAGRAM)

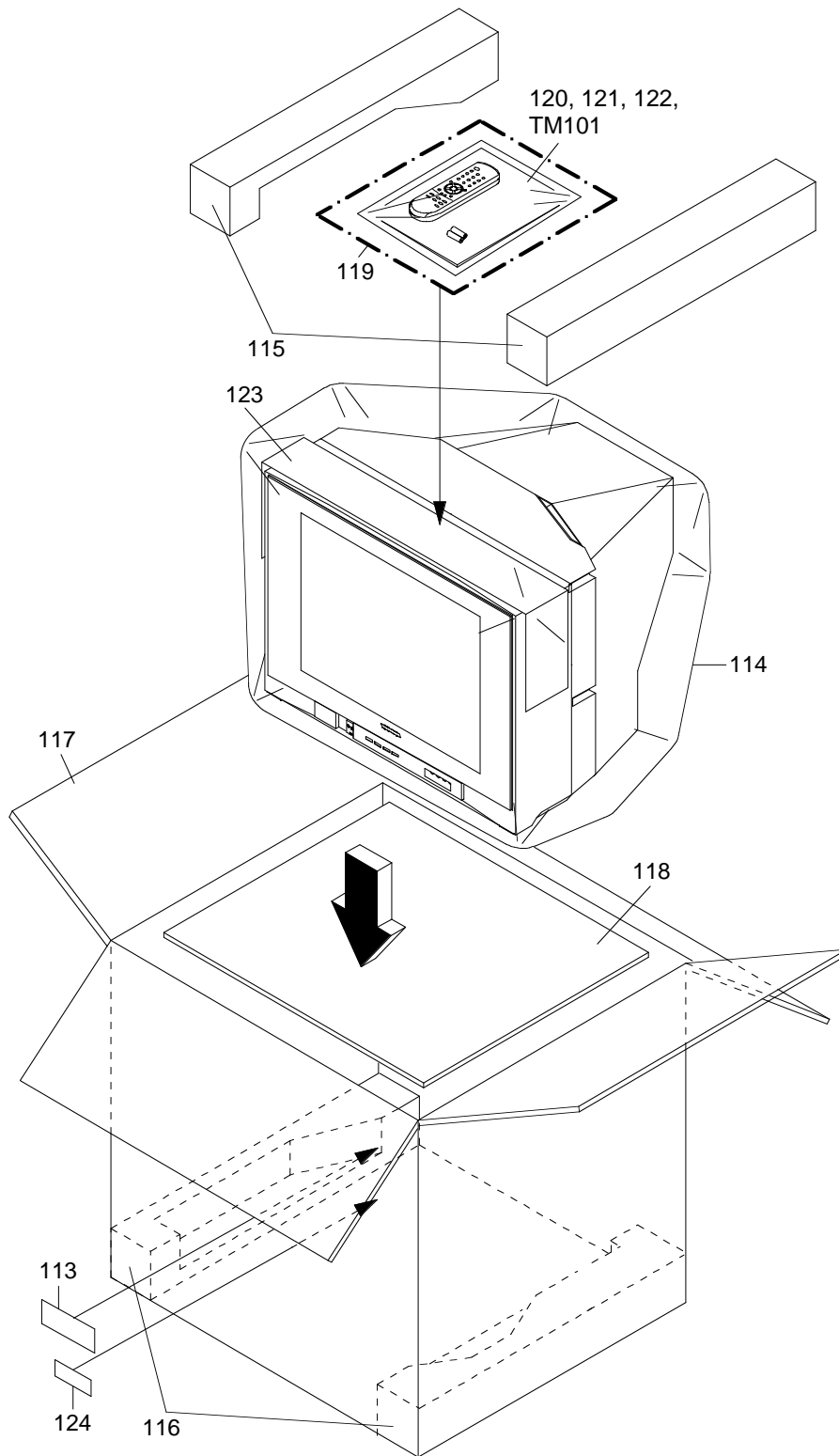

# MECHANICAL REPLACEMENT PARTS LIST

Location No.	TSB P/N	Reference No.	Description
101	72781165	7A701A423A	FRONT CABI ASS'Y
101A	72799331	701WPJD026	CABINET FRONT
101B	72782969	711WPA0184	PLATE FRONT
101C	72782972	713WPA0263	GLASS LED
101D	72799677	7235490049	BADGE BRAND
101E	72783010	735WPA0728	STOPPER BUTTON 1
101F	72794719	735WPA0732	STOPPER BUTTON 2
101G	72799770	735WPBB393	BUTTON FRAME
101H	72799793	735WPJA853	BUTTON POWER
101I	72794722	800WQ0A070	FELT SHEET
102	72781183	7A702A089A	BACK CABI ASS'Y
102A	72799347	702WPAA806	CABINET BACK
102B	72798774	800WQ0A045	FELT SHEET
103	72795687	741WUA0021	SPRING EARTH
104	72783310	722549A582	SHEET RATING
105	72783311	723000D284	POP LABEL
106	72794734	899HV3T000	HOLDER ANODE WIRE
107	72783312	726000A134	SHEET CRT SERVICEMAN
108	72798661	761WPA0220	HOLDER SPEAKER
109	72798684	762WPA0011	HOLDER CRT WIRE
110	72798781	800WROA002	SHEET CRT SUPPORT
111	72794733	801WRO0001	DAMPER SPEAKER
112	72798782	800WROA026	SHEET CRT SUPPORT (D)
113	72783313	723000D285	SHEET BARCODE
114	72795702	791WHAA114	FILM BAG
115	72798704	792WHA0432	PACKAGE TOP
116	72798705	792WHA0433	PACKAGE BOTTOM
117	72783314	793WCDD103	GIFT BOX
118	72781105	795WCDA011	PAD
119	72783330	A3S1032975	INSTRUCTION BOOK KIT
120	72781628	JA4ND200	POLYBAG INSTRUCTION(RED CAUTION)
121	72781569	J3N51617A	REGISTRATION CARD
122	72783315	J3S10321A	INSTRUCTION BOOK(E/S)
123	72795703	791WHAA134	LIGHTRON SHEET
201	72781287	8141J50C5U	SCREW TAP TITE(P) GW22 5*35 CH HEXAGON
202	72781279	8117540A6U	SCREW TAP TITE(B0) TRUSS 4*16 CH
203	72781276	8117140A2U	SCREW,TAPPING(B0) PAN 4*12 CH
204	72798791	8110630A0U	SCREW TAP TITE(P) BRAZIER 3*10 CH
205	72798786	810763080U	SCREW TAP TITE(S) BRAZIER 3*8 CH
206	72798789	8109I30A0U	SCREW TAP TITE(B) WH7 3*10 CH
207	72781251	810963080Q	SCREW TAP TITE(B) BRAZIER 3*8 STAINLESS
208	72781255	8109I3080U	SCREW TAP TITE(B) WH7 3*8 CH
209	72781295	8162540A6U	SCREW TAPPING (BO) WASHER 18

# MECHANICAL REPLACEMENT PARTS LIST

Location No.	TSB P/N	Reference No.	Description
101	72781165	7A701A423A	FRONT CABI ASS'Y
101A	72799331	701WPJD026	CABINET FRONT
101B	72782969	711WPA0184	PLATE FRONT
101C	72782972	713WPA0263	GLASS LED
101D	72799677	7235490049	BADGE BRAND
101E	72783010	735WPA0728	STOPPER BUTTON 1
101F	72794719	735WPA0732	STOPPER BUTTON 2
101G	72799770	735WPBB393	BUTTON FRAME
101H	72799793	735WPJA853	BUTTON POWER
101I	72794722	800WQ0A070	FELT SHEET
102	72781183	7A702A089A	BACK CABI ASS'Y
102A	72799347	702WPAA806	CABINET BACK
102B	72798774	800WQ0A045	FELT SHEET
103	72795687	741WUA0021	SPRING EARTH
104	72783321	722549A573	SHEET RATING
105	72783322	723000D261	POP LABEL
106	72794734	899HV3T000	HOLDER ANODE WIRE
107	72783312	726000A134	SHEET CRT SERVICEMAN
108	72798661	761WPA0220	HOLDER SPEAKER
109	72798684	762WPA0011	HOLDER CRT WIRE
110	72798781	800WROA002	SHEET CRT SUPPORT
111	72794733	801WRO0001	DAMPER SPEAKER
112	72798782	800WROA026	SHEET CRT SUPPORT (D)
113	72783323	723000D262	SHEET BARCODE
114	72795702	791WHAA114	FILM BAG
115	72798704	792WHA0432	PACKAGE TOP
116	72798705	792WHA0433	PACKAGE BOTTOM
117	72783324	793WCDD079	GIFT BOX
118	72781105	795WCDA011	PAD
119	72783325	A3S007S975	INSTRUCTION BOOK KIT
120	72795600	JA4ND100	POLYBAG INSTRUCTION(REDCAUTION)
122	72783326	J3S00721A	INSTRUCTION BOOK(E/F)
123	72795703	791WHAA134	LIGHTRON SHEET
124	72798549	7230007398	SECURITY TAG
125	72795593	722000A023	SHEET HWC
126	72795594	722000A267	SHEET CSA WARNING
201	72781287	8141J50C5U	SCREW TAP TITE(P) GW22 5*35 CH HEXAGON
202	72781279	8117540A6U	SCREW TAP TITE(B0) TRUSS 4*16 CH
203	72781276	8117140A2U	SCREW,TAPPING(B0) PAN 4*12 CH
204	72798791	8110630A0U	SCREW TAP TITE(P) BRAZIER 3*10 CH
205	72798786	810763080U	SCREW TAP TITE(S) BRAZIER 3*8 CH
206	72798789	8109I30A0U	SCREW TAP TITE(B) WH7 3*10 CH
207	72781251	810963080Q	SCREW TAP TITE(B) BRAZIER 3*8 STAINLESS
208	72781255	8109I3080U	SCREW TAP TITE(B) WH7 3*8 CH
209	72781295	8162540A6U	SCREW TAPPING (BO) WASHER 18

# ELECTRICAL REPLACEMENT PARTS LIST

Location No.	TSB P/N	Reference No.	Description	
<b>RESISTORS</b>				
△R402	72781748	R638U2680J	R,FUSE	68 OHM 1/2W
△R410	72795508	R3X18A151J	R,METAL OXIDE	150 OHM 2W
△R416	72797795	R002T23R3J	RC	3.3 OHM 1/2W
△R420	72794682	R002T22R7J	RC	2.7 OHM 1/2W
△R426	72794599	R4X5T4472F	R,METAL	4.7K OHM 1/4W
△R434	72795116	R5X2CF5R6J	R,CEMENT	5.6 OHM 10W
△R436	72795517	R4X5T4183F	R,METAL	18K OHM 1/4W
△R438	72781753	R655812R7J	R,FUSE	2.7 OHM 1W
△R439	72796031	R3K181102J	R,METAL OXIDE	1K OHM 1W
△R441	72795516	R4X5T6153F	R,METAL	15K OHM 1/6W
△R452	72797842	R3X181181J	R,METAL OXIDE	180 OHM 1W
△R500	72794631	R0G3K2275K	RC	2.7M OHM 1/2W
△R501	72795523	R5X2AE010J	R,C	1 OHM 7W
△R502	72795503	R3X28A331J	R,METAL OXIDE	330 OHM 2W
△R506	72794616	R002T4682J	RC	6.8K OHM 1/4W
△R517	72796002	R3X28BR22J	R,METAL OXIDE	0.22 OHM 3W
△R520	72795500	R002T2155J	RC	1.5M OHM 1/2W
△R527	72794624	R3X18AR68J	R,METAL OXIDE	0.68 OHM 2W
△R541	72794633	R63881R22J	R,FUSE	0.22 OHM 1W
△R542	72795513	R3X181R15J	R,METAL OXIDE	0.15 OHM 1W
△R602	72797913	R3X28B120J	R,METAL OXIDE	12 OHM 3W
△R649	72794641	R3X28B100J	R,METAL OXIDE	10 OHM 3W
△R803	72796459	R3X18A153J	R,METAL OXIDE	15K OHM 2W
△R805	72796459	R3X18A153J	R,METAL OXIDE	15K OHM 2W
△R807	72796459	R3X18A153J	R,METAL OXIDE	15K OHM 2W
<b>CAPACITORS</b>				
C408	72794410	E5EZF3102M	CE	1000 UF 25V
△C413	72797426	E0ELF4102M	CE	1000 UF 35V
C418	72794389	P4J7F3394J	CMPP	0.39 UF 250V PMS
△C420	72797697	P4N8FJ123H	CMPP	0.012 UF 1.25KV
C425	72794399	COPLRR713K	CC	0.001 UF 2KV R
△C426	72794394	E5EZF2220M	CE	22 UF 250V
△C430	72794396	E02LU8220M	CE	22 UF 100V
△C501	72795574	E02LF3222M	CE	2200 UF 25V
△C502	72794399	COPLRR713K	CC	0.001 UF 2KV R
△C503	72794399	COPLRR713K	CC	0.001 UF 2KV R
△C504	72795091	E02LU52R2M	CE	2.2 UF 50V
△C505	72795566	P2122B224M	CMP	0.22 UF 275V ECQUL
△C506	72795567	P2122B104M	CMP	0.1 UF 275V ECQUL
△C507	72795573	E51CGC471M	CE	470 UF 200V
△C508	72794403	CD39E0MH3M	CC	0.0022UF 250V
△C513	72797128	CD39E0ME3M	CC	0.0015UF 250V
△C514	72795574	E02LF3222M	CE	2200 UF 25V
△C517	72795581	COPLRR7E3K	CC	0.0015 UF 2KV R
△C519	72797128	CD39E0ME3M	CC	0.0015UF 250V
△C520	72795629	COJTB0513K	CC	0.001 UF 500V B
△C521	72781390	E61DFB221M	CE	220 UF 160V
△C527	72796330	E02LF2222M	CE	2200 UF 16V
C535	72796327	COPLRR7H3K	CC	0.0022 UF 2KV R
C626	72795577	CQG0B04Q3K	CC	0.0047UF 50V B
C802	72794440	COJBB07H3K	CC	0.0022UF 2KV B
<b>DIODES</b>				
D001	72794465	D97U03301B	DIODE,ZENER	MTZJ33B T-77
D104	72794491	D1VT001330	DIODE,SILICON	1SS133T-77
D105	72794491	D1VT001330	DIODE,SILICON	1SS133T-77
D106	72794469	D97U05R11B	DIODE,ZENER	MTZJ5.1B T-77
D109	72795529	0021721150	LED	SLR-342VCT32
D402	72794488	D2WT011E10	DIODE,SILICON	11E1-EIC
D403	72794471	D97U03001B	DIODE,ZENER	MTZJ30B T-77
D404	72794469	D97U05R11B	DIODE,ZENER	MTZJ5.1B T-77
△D405	72794472	D2WTAU02A0	DIODE,SILICON	AU02A-EIC
△D406	72794489	D97U05R61B	DIODE,ZENER	MTZJ5.6B T-77
△D407	72794472	D2WTAU02A0	DIODE,SILICON	AU02A-EIC
D410	72794471	D97U03001B	DIODE,ZENER	MTZJ30B T-77
△D411	72794472	D2WTAU02A0	DIODE,SILICON	AU02A-EIC
D414	72794488	D2WT011E10	DIODE,SILICON	11E1-EIC
D415	72794488	D2WT011E10	DIODE,SILICON	11E1-EIC
△D501	72794473	D2WTRM11C0	DIODE,SILICON	RM11C-EIC
△D502	72794473	D2WTRM11C0	DIODE,SILICON	RM11C-EIC
△D503	72794473	D2WTRM11C0	DIODE,SILICON	RM11C-EIC
△D504	72794473	D2WTRM11C0	DIODE,SILICON	RM11C-EIC
△D505	72794474	D28F0PRA60	DIODE,RECTIFIER	30PRA60-FC
△D506	72794483	D2WXN49370	DIODE,SILICON	1N4937
D507	72794491	D1VT001330	DIODE,SILICON	1SS133T-77
D508	72795542	D97U03R91B	DIODE,ZENER	MTZJ3.9B T-77

# ELECTRICAL REPLACEMENT PARTS LIST

Location No.	TSB P/N	Reference No.	Description	
<b>DIODES</b>				
D509	72795541	D97U01801B	DIODE,ZENER	MTZJ18B T-77
△D510	72794475	D2CF2016L0	DIODE,SILICON	FE201-6L49
△D511	72794483	D2WXN49370	DIODE,SILICON	1N4937
△D512	72794480	D28T21DQN9	DIODE,SCHOTTKY	21DQ09N-TA2B1
D513	72794491	D1VT001330	DIODE,SILICON	1SS133T-77
D514	72794491	D1VT001330	DIODE,SILICON	1SS133T-77
D516	72794491	D1VT001330	DIODE,SILICON	1SS133T-77
D517	72794491	D1VT001330	DIODE,SILICON	1SS133T-77
D520	72794491	D1VT001330	DIODE,SILICON	1SS133T-77
△D523	72795541	D97U01801B	DIODE,ZENER	MTZJ18B T-77
△D524	72794491	D1VT001330	DIODE,SILICON	1SS133T-77
D525	72794487	D97U01201B	DIODE,ZENER	MTZJ12B T-77
D528	72794489	D97U05R61B	DIODE,ZENER	MTZJ5.6B T-77
D601	72794491	D1VT001330	DIODE,SILICON	1SS133T-77
D602	72794486	D97U08R21B	DIODE,ZENER	MTZJ8.2B T-77
D604	72794487	D97U01201B	DIODE,ZENER	MTZJ12B T-77
D605	72794491	D1VT001330	DIODE,SILICON	1SS133T-77
D606	72794491	D1VT001330	DIODE,SILICON	1SS133T-77
D607	72794491	D1VT001330	DIODE,SILICON	1SS133T-77
D608	72794488	D2WT011E10	DIODE,SILICON	11E1-EIC
D701	72794487	D97U01201B	DIODE,ZENER	MTZJ12B T-77
D702	72794487	D97U01201B	DIODE,ZENER	MTZJ12B T-77
D703	72794487	D97U01201B	DIODE,ZENER	MTZJ12B T-77
D704	72794487	D97U01201B	DIODE,ZENER	MTZJ12B T-77
D706	72794487	D97U01201B	DIODE,ZENER	MTZJ12B T-77
D709	72794490	D97U06R21B	DIODE,ZENER	MTZJ6.2B T-77
D801	72794491	D1VT001330	DIODE,SILICON	1SS133T-77
D802	72794491	D1VT001330	DIODE,SILICON	1SS133T-77
D803	72794491	D1VT001330	DIODE,SILICON	1SS133T-77
D810	72794491	D1VT001330	DIODE,SILICON	1SS133T-77
D811	72794491	D1VT001330	DIODE,SILICON	1SS133T-77
D812	72794491	D1VT001330	DIODE,SILICON	1SS133T-77
<b>ICS</b>				
IC101	72795533	I56F07090B	IC	OEC7090B
IC199	72782885	A3S001U015	INIT DATA	BR24L16FJ-WE2
IC302	72794498	I01FF58910	IC	AN5891SA-E1V
△IC401	72795534	I03TD804N0	IC	LA78040N-E
△IC504	72795524	0002E00610	PHOTO COUPLER	LTV-817M-VB
IC601	72794514	I06FC1283B	IC	M61283BFP
IC902	72795535	I01FF58290	IC	AN5829S-E1V
△IC1001	72795908	I0FSP7522N	IC	AN7522N
IC1501	72794500	I05FEA45FG	IC	TC90A45FG
IC1502	72794502	I0UF015010	IC	MM1501XNRE
IC1503	72794502	I0UF015010	IC	MM1501XNRE
<b>TRANSISTORS</b>				
Q101	72794571	TCAA3875SY	TRANSISTOR,SILICON	KTC3875S_Y_RTK
Q103	72794571	TCAA3875SY	TRANSISTOR,SILICON	KTC3875S_Y_RTK
△Q402	72794561	TCAT03227Y	TRANSISTOR,SILICON	KTC3227_Y-AT
△Q405	72782813	TC1G058850	TRANSISTOR,SILICON	2SC5885
△Q502	72795540	T220033260	FET	2SK3326(2)
△Q503	72795475	TA3T1371A0	TRANSISTOR,SILICON	2SA1371(D,E)-AE
Q504	72794577	TCATC31980	TRANSISTOR,SILICON	KTC3198-AT(Y,GR)
△Q505	72795474	TC3T029090	TRANSISTOR,SILICON	2SC2909(S,T)-AA
△Q507	72794577	TCATC31980	TRANSISTOR,SILICON	KTC3198-AT(Y,GR)
△Q512	72794569	TA3T016240	TRANSISTOR,SILICON	2SA1624-AA
△Q514	72795476	TCAT032034	TRANSISTOR,SILICON	KTC3203_Y-AT
Q601	72794570	TCAT03209Y	TRANSISTOR,SILICON	KTC3209_Y-AT
Q602	72794570	TCAT03209Y	TRANSISTOR,SILICON	KTC3209_Y-AT
Q604	72794570	TCAT03209Y	TRANSISTOR,SILICON	KTC3209_Y-AT
Q606	72794570	TCAT03209Y	TRANSISTOR,SILICON	KTC3209_Y-AT
Q607	72795476	TCAT032034	TRANSISTOR,SILICON	KTC3203_Y-AT
Q611	72794570	TCAT03209Y	TRANSISTOR,SILICON	KTC3209_Y-AT
△Q801	72794573	TCATC3199Y	TRANSISTOR,SILICON	KTC3199_Y-AT
△Q802	72794573	TCATC3199Y	TRANSISTOR,SILICON	KTC3199_Y-AT
△Q803	72794573	TCATC3199Y	TRANSISTOR,SILICON	KTC3199_Y-AT
△Q804	72795971	TC3F042170	TRANSISTOR,SILICON	2SC4217(D,E)-RAC
△Q805	72795971	TC3F042170	TRANSISTOR,SILICON	2SC4217(D,E)-RAC
△Q806	72795971	TC3F042170	TRANSISTOR,SILICON	2SC4217(D,E)-RAC
Q1501	72795970	T6YJ1037K0	TRANSISTOR,SILICON	2SA1037AKT146R,S
Q1502	72794571	TCAA3875SY	TRANSISTOR,SILICON	KTC3875S_Y_RTK
Q1505	72794571	TCAA3875SY	TRANSISTOR,SILICON	KTC3875S_Y_RTK
Q1507	72794571	TCAA3875SY	TRANSISTOR,SILICON	KTC3875S_Y_RTK
<b>COILS &amp; TRANSFORMERS</b>				
L301	72794540	02167F101J	COIL	100 UH
L401	72794527	021679472K	COIL	4.7 MH

# ELECTRICAL REPLACEMENT PARTS LIST

Location No.	TSB P/N	Reference No.	Description	
<b>COILS &amp; TRANSFORMERS</b>				
L402	72794528	022100027A	COIL,LINEARITY	ELH5L4113
△L501	72796630	029T000097	COIL,LINE FILTER	1R5A123F28Y
△L503	72795933	028R200024	COIL,DEGAUSS	8R200024
L901	72794540	02167F101J	COIL	100 UH
L1501	72794540	02167F101J	COIL	100 UH
L1503	72795062	02167F100J	COIL	10 UH
L1504	72795932	02167F150J	COIL	15 UH
L1507	72796571	021LA6220J	COIL	22 UH
T401	72796055	045013003J	TRANS,HORIZONTAL DRIVE	ETH14Y47AY
△T501	72798977	048135091S	TRANSFORMER,SWITCHING	8135091S
<b>JACKS</b>				
J701	72794518	060J431020	RCA JACK	MSP-213V2-432_NI_LF
J702	72794517	063Q700011	JACK	YKF51-5503N
J704	72795493	060J411032	RCA JACK	MSP-213V1-652_NI_LF
J705	72794519	060J401104	RCA JACK	MTJ-032-03A-30FE
J706	72794520	060J401106	RCA JACK	MTJ-032-03A-32FE
J707	72794521	060J401105	RCA JACK	MTJ-032-03A-31FE
△J801	72795490	066F130020	SOCKET,CATHODE RAY,TUBE	ISHS53S
△J1001	72794516	060J131016	HEADPHONE JACK	MSJ-2000_AG
<b>SWITCHES</b>				
SW101	72794688	0504101T34	SWITCH,TACT	EVQ21505R
SW102	72794688	0504101T34	SWITCH,TACT	EVQ21505R
SW103	72794688	0504101T34	SWITCH,TACT	EVQ21505R
SW104	72794688	0504101T34	SWITCH,TACT	EVQ21505R
SW105	72794688	0504101T34	SWITCH,TACT	EVQ21505R
<b>VARIABLE RESISTORS</b>				
VR401	72795471	V1K63H3BTE	VOLUME,SEMI FIXED	NVG6TLTAB222
VR502	72794701	V1163H4BTC	VOLUME,SEMI FIXED	EVNCYAA03BE4
<b>P.C.BOARD ASSEMBLIES</b>				
PCB010	72783316	A3S006S010L	PCB ASS'Y	CME017B
PCB110	72783317	A3S006S110L	PCB ASS'Y	CCE011B
<b>MISCELLANEOUS</b>				
B501	72795549	024AT03481	CORE,BEADS	BL02RN1-R62T2
B504	72794357	024HT03553	CORE,BEADS	W5RH3.5X5X1.0
B1502	72794357	024HT03553	CORE,BEADS	W5RH3.5X5X1.0
BT001	72783174	141U004016	BATTERY,MANGAN	MNAAA(R03)
BT002	72783174	141U004016	BATTERY,MANGAN	MNAAA(R03)
△CD501	72795553	1209615904	CORD,AC BUSH	9615904
CD801	72798401	WCL6836038	FLAT CABLE	AWM2468 AWG26 5C GRAY 360MM
CD802	72798421	WDL6046038	FLAT CABLE	AWM2468 AWG26 6C BLACK 460MM
CD803	72783318	06CH823006	CORD,CONNECTOR	CH823006
CP101	72782677	0694270139	CONNECTOR PCB SIDE	173979-7
△CP401	72782003	069X460109	CONNECTOR PCB SIDE	B06B-DVS-L_(LF)
△CP501	72796817	069S320419	CONNECTOR PCB SIDE	A3963WV2-3PD
△CP502	72796821	069S420110	CONNECTOR PCB SIDE	A1561WV2-2P
CP507	72796768	069D01001A	CONNECTOR PCB SIDE	003P-2100
CP508	72796768	069D01001A	CONNECTOR PCB SIDE	003P-2100
CP803	72796816	069S320010	CONNECTOR PCB SIDE	A2361WV2-2P
CP806	72796824	069W010010	CONNECTOR PCB SIDE	005P-2100
CD1001	72783319	06CU14411A	CORD,CONNECTOR	CU14411A
CP1001	72796793	069S140419	CONNECTOR PCB SIDE	A2502WV2-4P
CP801A	72796751	067U005049	WIRE HOLDER	B2013H02-5P
CP801B	72796751	067U005049	WIRE HOLDER	B2013H02-5P
CP802A	72796752	067U006049	WIRE HOLDER	B2013H02-6P
CP802B	72796752	067U006049	WIRE HOLDER	B2013H02-6P
CUS011	72795888	800WFAA008	CUSHION C	
EL001	72797070	124120301A	EYE LET	XRY20X30BD
EL002	72797069	124116281A	EYE LET	XRY16X28BD
△F501	72794493	081PC6R305	FUSE	51MS063L
△FB401	72796667	043220060F	TRANSFORMER,FLYBACK	FJN20A002_M
FH501	72794496	06710T0009	HOLDER,FUSE	EYF-52BCY
FH502	72794496	06710T0009	HOLDER,FUSE	EYF-52BCY
OS101	72794541	0773071001	REMOTE RECEIVER	RPM7138-WH5
△RY501	72794686	0560X20118	RELAY	G5PA-1-SA(WEC)
△SP1001	72799164	070N457008	SPEAKER	YDP512-22
△SP1002	72799164	070N457008	SPEAKER	YDP512-22
△TH501	72794693	D8EE0B1400	DEGAUSS ELEMENT	B59203-S1060-B14
TM101	72799199	076N0GQ020	TRANSMITTER	RC-GQ020
△TU001	72795492	0163300018	RF UNIT	115-V-KA35ARB
△V801	72783320	0981210468	CRT W/DY	A51LYZ295X81
X101	72794702	100CT8R005	CRYSTAL	HC-49/U-S
X602	72794704	100DT3R531	CRYSTAL	HC-49/U

# ELECTRICAL REPLACEMENT PARTS LIST

## RESISTOR

RC..... CARBON RESISTOR

## CAPACITORS

CC..... CERAMIC CAPACITOR  
CE..... ALUMI ELECTROLYTIC CAPACITOR  
CP..... POLYESTER CAPACITOR  
CPP..... POLYPROPYLENE CAPACITOR  
CPL..... PLASTIC CAPACITOR  
CMP..... METAL POLYESTER CAPACITOR  
CMPL..... METAL PLASTIC CAPACITOR  
CMPP..... METAL POLYPROPYLENE CAPACITOR

# ELECTRICAL REPLACEMENT PARTS LIST

Location No.	TSB P/N	Reference No.	Description	
<b>RESISTORS</b>				
△R402	72781748	R638U2680J	R,FUSE	68 OHM 1/2W
△R410	72795508	R3X18A151J	R,METAL OXIDE	150 OHM 2W
△R416	72797795	R002T23R3J	RC	3.3 OHM 1/2W
△R420	72794682	R002T22R7J	RC	2.7 OHM 1/2W
△R426	72794599	R4X5T4472F	R,METAL	4.7K OHM 1/4W
△R434	72795116	R5X2CF5R6J	R,CEMENT	5.6 OHM 10W
△R436	72795517	R4X5T4183F	R,METAL	18K OHM 1/4W
△R438	72781753	R655812R7J	R,FUSE	2.7 OHM 1W
△R439	72796031	R3K181102J	R,METAL OXIDE	1K OHM 1W
△R441	72795516	R4X5T6153F	R,METAL	15K OHM 1/6W
△R452	72797842	R3X181181J	R,METAL OXIDE	180 OHM 1W
△R500	72794631	R0G3K2275K	RC	2.7M OHM 1/2W
△R501	72795523	R5X2AE010J	R,CEMENT	1 OHM 7W
△R502	72795503	R3X28A331J	R,METAL OXIDE	330 OHM 2W
△R506	72794616	R002T4682J	RC	6.8K OHM 1/4W
△R517	72796002	R3X28BR22J	R,METAL OXIDE	0.22 OHM 3W
△R520	72795500	R002T2155J	RC	1.5M OHM 1/2W
△R527	72794624	R3X18AR68J	R,METAL OXIDE	0.68 OHM 2W
△R541	72794633	R63881R22J	R,FUSE	0.22 OHM 1W
△R542	72795513	R3X181R15J	R,METAL OXIDE	0.15 OHM 1W
△R602	72797913	R3X28B120J	R,METAL OXIDE	12 OHM 3W
△R649	72794641	R3X28B100J	R,METAL OXIDE	10 OHM 3W
△R803	72796459	R3X18A153J	R,METAL OXIDE	15K OHM 2W
△R805	72796459	R3X18A153J	R,METAL OXIDE	15K OHM 2W
△R807	72796459	R3X18A153J	R,METAL OXIDE	15K OHM 2W
<b>CAPACITORS</b>				
C408	72794410	E5EZF3102M	CE	1000 UF 25V
△C413	72797426	E0ELF4102M	CE	1000 UF 35V
C418	72794389	P4J7F3394J	CMPP	0.39 UF 250V PMS
△C420	72797697	P4N8FJ123H	CMPP	0.012 UF 1.25KV
C425	72794399	COPLRR713K	CC	0.001 UF 2KV R
△C426	72794394	E5EZF2220M	CE	22 UF 250V
△C430	72794396	E02LU8220M	CE	22 UF 100V
△C501	72795574	E02LF3222M	CE	2200 UF 25V
△C502	72794399	COPLRR713K	CC	0.001 UF 2KV R
△C503	72794399	COPLRR713K	CC	0.001 UF 2KV R
△C504	72795091	E02LU52R2M	CE	2.2 UF 50V
△C505	72795566	P2122B224M	CMP	0.22 UF 275V ECQUL
△C506	72795567	P2122B104M	CMP	0.1 UF 275V ECQUL
△C507	72795573	E51CGC471M	CE	470 UF 200V
△C508	72794403	CD39E0MH3M	CC	0.0022UF 250V
△C513	72797128	CD39E0ME3M	CC	0.0015UF 250V
△C514	72795574	E02LF3222M	CE	2200 UF 25V
△C517	72795581	COPLRR7E3K	CC	0.0015 UF 2KV R
△C519	72797128	CD39E0ME3M	CC	0.0015UF 250V
△C520	72795629	COJTB0513K	CC	0.001 UF 500V B
△C521	72781390	E61DFB221M	CE	220 UF 160V
△C527	72796330	E02LF2222M	CE	2200 UF 16V
C535	72796327	COPLRR7H3K	CC	0.0022 UF 2KV R
C626	72795577	CQG0B04Q3K	CC	0.0047UF 50V B
C802	72794440	COJBB07H3K	CC	0.0022UF 2KV B
<b>DIODES</b>				
D001	72794465	D97U03301B	DIODE,ZENER	MTZJ33B T-77
D104	72794491	D1VT001330	DIODE,SILICON	1SS133T-77
D105	72794491	D1VT001330	DIODE,SILICON	1SS133T-77
D106	72794469	D97U05R11B	DIODE,ZENER	MTZJ5.1B T-77
D109	72795529	0021721150	LED	SLR-342VCT32
D402	72794488	D2WT011E10	DIODE,SILICON	11E1-EIC
D403	72794471	D97U03001B	DIODE,ZENER	MTZJ30B T-77
D404	72794469	D97U05R11B	DIODE,ZENER	MTZJ5.1B T-77
△D405	72794472	D2WTAU02A0	DIODE,SILICON	AU02A-EIC
△D406	72794489	D97U05R61B	DIODE,ZENER	MTZJ5.6B T-77
△D407	72794472	D2WTAU02A0	DIODE,SILICON	AU02A-EIC
D410	72794471	D97U03001B	DIODE,ZENER	MTZJ30B T-77
△D411	72794472	D2WTAU02A0	DIODE,SILICON	AU02A-EIC
D414	72794488	D2WT011E10	DIODE,SILICON	11E1-EIC
D415	72794488	D2WT011E10	DIODE,SILICON	11E1-EIC
△D501	72794473	D2WTRM11C0	DIODE,SILICON	RM11C-EIC
△D502	72794473	D2WTRM11C0	DIODE,SILICON	RM11C-EIC
△D503	72794473	D2WTRM11C0	DIODE,SILICON	RM11C-EIC
△D504	72794473	D2WTRM11C0	DIODE,SILICON	RM11C-EIC
△D505	72794474	D28F0PRA60	DIODE,RECTIFIER	30PRA60-FC
△D506	72794483	D2WXN49370	DIODE,SILICON	1N4937
D507	72794491	D1VT001330	DIODE,SILICON	1SS133T-77
D508	72795542	D97U03R91B	DIODE,ZENER	MTZJ3.9B T-77

# ELECTRICAL REPLACEMENT PARTS LIST

Location No.	TSB P/N	Reference No.	Description	
<b>DIODES</b>				
D509	72795541	D97U01801B	DIODE,ZENER	MTZJ18B T-77
△D510	72794475	D2CF2016L0	DIODE,SILICON	FE201-6L49
△D511	72794483	D2WXN49370	DIODE,SILICON	1N4937
△D512	72794480	D28T21DQN9	DIODE,SCHOTTKY	21DQ09N-TA2B1
D513	72794491	D1VT001330	DIODE,SILICON	1SS133T-77
D514	72794491	D1VT001330	DIODE,SILICON	1SS133T-77
D516	72794491	D1VT001330	DIODE,SILICON	1SS133T-77
D517	72794491	D1VT001330	DIODE,SILICON	1SS133T-77
D520	72794491	D1VT001330	DIODE,SILICON	1SS133T-77
△D523	72795541	D97U01801B	DIODE,ZENER	MTZJ18B T-77
△D524	72794491	D1VT001330	DIODE,SILICON	1SS133T-77
D525	72794487	D97U01201B	DIODE,ZENER	MTZJ12B T-77
D528	72794489	D97U05R61B	DIODE,ZENER	MTZJ5.6B T-77
D601	72794491	D1VT001330	DIODE,SILICON	1SS133T-77
D602	72794486	D97U08R21B	DIODE,ZENER	MTZJ8.2B T-77
D604	72794487	D97U01201B	DIODE,ZENER	MTZJ12B T-77
D605	72794491	D1VT001330	DIODE,SILICON	1SS133T-77
D606	72794491	D1VT001330	DIODE,SILICON	1SS133T-77
D607	72794491	D1VT001330	DIODE,SILICON	1SS133T-77
D608	72794488	D2WT011E10	DIODE,SILICON	11E1-EIC
D701	72794487	D97U01201B	DIODE,ZENER	MTZJ12B T-77
D702	72794487	D97U01201B	DIODE,ZENER	MTZJ12B T-77
D703	72794487	D97U01201B	DIODE,ZENER	MTZJ12B T-77
D704	72794487	D97U01201B	DIODE,ZENER	MTZJ12B T-77
D706	72794487	D97U01201B	DIODE,ZENER	MTZJ12B T-77
D709	72794490	D97U06R21B	DIODE,ZENER	MTZJ6.2B T-77
D801	72794491	D1VT001330	DIODE,SILICON	1SS133T-77
D802	72794491	D1VT001330	DIODE,SILICON	1SS133T-77
D803	72794491	D1VT001330	DIODE,SILICON	1SS133T-77
D810	72794491	D1VT001330	DIODE,SILICON	1SS133T-77
D811	72794491	D1VT001330	DIODE,SILICON	1SS133T-77
D812	72794491	D1VT001330	DIODE,SILICON	1SS133T-77
<b>ICS</b>				
IC101	72795533	I56F07090B	IC	OEC7090B
IC199	72783327	A3S002U015L	INIT DATA	
IC302	72794498	I01FF58910	IC	AN5891SA-E1V
△IC401	72795534	I03TD804N0	IC	LA78040N-E
△IC504	72795524	0002E00610	PHOTO COUPLER	LTV-817M-VB
IC601	72794514	I06FC1283B	IC	M61283BFP
IC902	72795535	I01FF58290	IC	AN5829S-E1V
△IC1001	72795908	I0FSP7522N	IC	AN7522N
IC1501	72794500	I05FEA45FG	IC	TC90A45FG
IC1502	72794502	I0UF015010	IC	MM1501XNRE
IC1503	72794502	I0UF015010	IC	MM1501XNRE
<b>TRANSISTORS</b>				
Q101	72794571	TCAA3875SY	TRANSISTOR,SILICON	KTC3875S_Y_RTK
Q103	72794571	TCAA3875SY	TRANSISTOR,SILICON	KTC3875S_Y_RTK
△Q402	72794561	TCAT03227Y	TRANSISTOR,SILICON	KTC3227_Y-AT
△Q405	72782813	TC1G058850	TRANSISTOR,SILICON	2SC5885
△Q502	72795540	T220033260	FET	2SK3326(2)
△Q503	72795475	TA3T1371A0	TRANSISTOR,SILICON	2SA1371(D,E)-AE
Q504	72794577	TCATC31980	TRANSISTOR,SILICON	KTC3198-AT(Y,GR)
△Q505	72795474	TC3T029090	TRANSISTOR,SILICON	2SC2909(S,T)-AA
△Q507	72794577	TCATC31980	TRANSISTOR,SILICON	KTC3198-AT(Y,GR)
△Q512	72794569	TA3T016240	TRANSISTOR,SILICON	2SA1624-AA
△Q514	72795476	TCAT032034	TRANSISTOR,SILICON	KTC3203_Y-AT
Q601	72794570	TCAT03209Y	TRANSISTOR,SILICON	KTC3209_Y-AT
Q602	72794570	TCAT03209Y	TRANSISTOR,SILICON	KTC3209_Y-AT
Q604	72794570	TCAT03209Y	TRANSISTOR,SILICON	KTC3209_Y-AT
Q606	72794570	TCAT03209Y	TRANSISTOR,SILICON	KTC3209_Y-AT
Q607	72795476	TCAT032034	TRANSISTOR,SILICON	KTC3203_Y-AT
Q611	72794570	TCAT03209Y	TRANSISTOR,SILICON	KTC3209_Y-AT
△Q801	72794573	TCATC3199Y	TRANSISTOR,SILICON	KTC3199_Y-AT
△Q802	72794573	TCATC3199Y	TRANSISTOR,SILICON	KTC3199_Y-AT
△Q803	72794573	TCATC3199Y	TRANSISTOR,SILICON	KTC3199_Y-AT
△Q804	72795971	TC3F042170	TRANSISTOR,SILICON	2SC4217(D,E)-RAC
△Q805	72795971	TC3F042170	TRANSISTOR,SILICON	2SC4217(D,E)-RAC
△Q806	72795971	TC3F042170	TRANSISTOR,SILICON	2SC4217(D,E)-RAC
Q1501	72795970	T6YJ1037K0	TRANSISTOR,SILICON	2SA1037AKT146R,S
Q1502	72794571	TCAA3875SY	TRANSISTOR,SILICON	KTC3875S_Y_RTK
Q1505	72794571	TCAA3875SY	TRANSISTOR,SILICON	KTC3875S_Y_RTK
Q1507	72794571	TCAA3875SY	TRANSISTOR,SILICON	KTC3875S_Y_RTK
<b>COILS &amp; TRANSFORMERS</b>				
L301	72794540	02167F101J	COIL	100 UH
L401	72794527	021679472K	COIL	4.7 MH

# ELECTRICAL REPLACEMENT PARTS LIST

Location No.	TSB P/N	Reference No.	Description	
<b>COILS &amp; TRANSFORMERS</b>				
L402	72794528	022100027A	COIL,LINEARITY	ELH5L4113
△L501	72796630	029T000097	COIL,LINE FILTER	1R5A123F28Y
△L503	72795933	028R200024	COIL,DEGAUSS	8R200024
L901	72794540	02167F101J	COIL	100 UH
L1501	72794540	02167F101J	COIL	100 UH
L1503	72795062	02167F100J	COIL	10 UH
L1504	72795932	02167F150J	COIL	15 UH
L1507	72796571	021LA6220J	COIL	22 UH
T401	72796055	045013003J	TRANS,HORIZONTAL DRIVE	ETH14Y47AY
△T501	72798977	048135091S	TRANSFORMER,SWITCHING	8135091S
<b>JACKS</b>				
J701	72794518	060J431020	RCA JACK	MSP-213V2-432_NI_LF
J702	72794517	063Q700011	JACK	YKF51-5503N
J704	72795493	060J411032	RCA JACK	MSP-213V1-652_NI_LF
J705	72794519	060J401104	RCA JACK	MTJ-032-03A-30FE
J706	72794520	060J401106	RCA JACK	MTJ-032-03A-32FE
J707	72794521	060J401105	RCA JACK	MTJ-032-03A-31FE
△J801	72795490	066F130020	SOCKET,CATHODE RAY,TUBE	ISHS53S
△J1001	72794516	060J131016	HEADPHONE JACK	MSJ-2000_AG
<b>SWITCHES</b>				
SW101	72794688	0504101T34	SWITCH,TACT	EVQ21505R
SW102	72794688	0504101T34	SWITCH,TACT	EVQ21505R
SW103	72794688	0504101T34	SWITCH,TACT	EVQ21505R
SW104	72794688	0504101T34	SWITCH,TACT	EVQ21505R
SW105	72794688	0504101T34	SWITCH,TACT	EVQ21505R
<b>VARIABLE RESISTORS</b>				
VR401	72795471	V1K63H3BTE	VOLUME,SEMI FIXED	NVG6TLTAB222
VR502	72794701	V1163H4BTC	VOLUME,SEMI FIXED	EVNCYAA03BE4
<b>P.C.BOARD ASSEMBLIES</b>				
PCB010	72783328	A3S007S010L	PCB ASS'Y	CME017B
PCB110	72783317	A3S006S110L	PCB ASS'Y	CCE011B
<b>MISCELLANEOUS</b>				
B501	72795549	024AT03481	CORE,BEADS	BL02RN1-R62T2
B504	72794357	024HT03553	CORE,BEADS	W5RH3.5X5X1.0
B1502	72794357	024HT03553	CORE,BEADS	W5RH3.5X5X1.0
BT001	72783174	141U004016	BATTERY,MANGAN	MNAAA(R03)
BT002	72783174	141U004016	BATTERY,MANGAN	MNAAA(R03)
△CD501	72795553	1209615904	CORD,AC BUSH	9615904
CD801	72798401	WCL6836038	FLAT CABLE	AWM2468 AWG26 5C GRAY 360MM
CD802	72798421	WDL6046038	FLAT CABLE	AWM2468 AWG26 6C BLACK 460MM
CD803	72783318	06CH823006	CORD,CONNECTOR	CH823006
CP101	72782677	0694270139	CONNECTOR PCB SIDE	173979-7
△CP401	72782003	069X460109	CONNECTOR PCB SIDE	B06B-DVS-L_(LF)
△CP501	72796817	069S320419	CONNECTOR PCB SIDE	A3963WV2-3PD
△CP502	72796821	069S420110	CONNECTOR PCB SIDE	A1561WV2-2P
CP507	72796768	069D01001A	CONNECTOR PCB SIDE	003P-2100
CP508	72796768	069D01001A	CONNECTOR PCB SIDE	003P-2100
CP803	72796816	069S320010	CONNECTOR PCB SIDE	A2361WV2-2P
CP806	72796824	069W010010	CONNECTOR PCB SIDE	005P-2100
CD1001	72783319	06CU14411A	CORD,CONNECTOR	CU14411A
CP1001	72796793	069S140419	CONNECTOR PCB SIDE	A2502WV2-4P
CP801A	72796751	067U005049	WIRE HOLDER	B2013H02-5P
CP801B	72796751	067U005049	WIRE HOLDER	B2013H02-5P
CP802A	72796752	067U006049	WIRE HOLDER	B2013H02-6P
CP802B	72796752	067U006049	WIRE HOLDER	B2013H02-6P
CUS011	72795888	800WFAA008	CUSHION C	
EL001	72797070	124120301A	EYE LET	XRY20X30BD
EL002	72797069	124116281A	EYE LET	XRY16X28BD
△F501	72794493	081PC6R305	FUSE	51MS063L
△FB401	72796667	043220060F	TRANSFORMER,FLYBACK	FJN20A002_M
FH501	72794496	06710T0009	HOLDER,FUSE	EYF-52BCY
FH502	72794496	06710T0009	HOLDER,FUSE	EYF-52BCY
OS101	72794541	0773071001	REMOTE RECEIVER	RPM7138-WH5
△RY501	72794686	0560X20118	RELAY	G5PA-1-SA(WEC)
△SP1001	72799164	070N457008	SPEAKER	YDP512-22
△SP1002	72799164	070N457008	SPEAKER	YDP512-22
△TH501	72794693	D8EE0B1400	DEGAUSS ELEMENT	B59203-S1060-B14
TM101	72799199	076N0GQ020	TRANSMITTER	RC-GQ020
△TU001	72795492	0163300018	RF UNIT	115-V-KA35ARB
△V801	72783320	0981210468	CRT W/DY	A51LYZ295X81
X101	72794702	100CT8R005	CRYSTAL	HC-49/U-S
X602	72794704	100DT3R531	CRYSTAL	HC-49/U

# ELECTRICAL REPLACEMENT PARTS LIST

## RESISTOR

RC..... CARBON RESISTOR

## CAPACITORS

CC..... CERAMIC CAPACITOR  
CE..... ALUMI ELECTROLYTIC CAPACITOR  
CP..... POLYESTER CAPACITOR  
CPP..... POLYPROPYLENE CAPACITOR  
CPL..... PLASTIC CAPACITOR  
CMP..... METAL POLYESTER CAPACITOR  
CMPL..... METAL PLASTIC CAPACITOR  
CMPP..... METAL POLYPROPYLENE CAPACITOR

# **TOSHIBA CORPORATION**

1-1, SHIBAURA 1-CHOME, MINATO-KU, TOKYO 105-8001, JAPAN