

TOSHIBA

FILE NO. 050-200540GR
(MFR'S VERSION B)

SERVICE MANUAL

COLOR TELEVISION

27AF46C

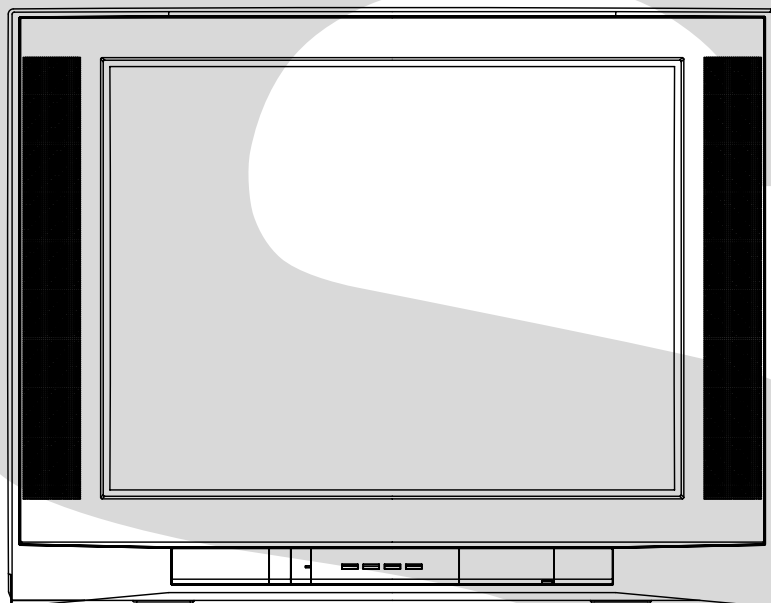

The above model is classified as a green product (*1), as indicated by the underlined serial number. This Service Manual describes replacement parts for the green product. When repairing this green product, use the part(s) described in this manual and lead-free solder (*2).

For (*1) and (*2), see the next page.

(*1)

GREEN PRODUCT PROCUREMENT

The EC is actively promoting the WEEE & RoHS Directives that define standards for recycling and reuse of Waste Electrical and Electronic Equipment and for the Restriction of the use of certain Hazardous Substances. From July 1, 2006, the RoHS Directive will prohibit any marketing of new products containing the restricted substances.

Increasing attention is given to issues related to the global environmental. Toshiba Corporation recognizes environmental protection as a key management tasks, and is doing its utmost to enhance and improve the quality and scope of its environmental activities. In line with this, Toshiba proactively promotes Green Procurement, and seeks to purchase and use products, parts and materials that have low environmental impacts.

Green procurement of parts is not only confined to manufacture. The same green parts used in manufacture must also be used as replacement parts.

(*2)

LEAD-FREE SOLDER

This product is manufactured using lead-free solder as a part of a movement within the consumer products industry at large to be environmentally responsible. Lead-free solder must be used in the servicing and repair of this product.

WARNING

This product is manufactured using lead free solder.

DO NOT USE LEAD BASED SOLDER TO REPAIR THIS PRODUCT !

The melting temperature of lead-free solder is higher than that of leaded solder by 86°F to 104°F (30°C to 40°C). Use of a soldering iron designed for lead-based solders to repair product made with lead-free solder may result in damage to the component and or PCB being soldered. Great care should be made to ensure high-quality soldering when servicing this product — especially when soldering large components, through-hole pins, and on PCBs — as the level of heat required to melt lead-free solder is high.

SERVICING NOTICES ON CHECKING

1. KEEP THE NOTICES

As for the places which need special attentions, they are indicated with the labels or seals on the cabinet, chassis and parts. Make sure to keep the indications and notices in the operation manual.

2. AVOID AN ELECTRIC SHOCK

There is a high voltage part inside. Avoid an electric shock while the electric current is flowing.

3. USE THE DESIGNATED PARTS

The parts in this equipment have the specific characters of incombustibility and withstand voltage for safety. Therefore, the part which is replaced should be used the part which has the same character.

Especially as to the important parts for safety which is indicated in the circuit diagram or the table of parts as a  mark, the designated parts must be used.

4. PUT PARTS AND WIRES IN THE ORIGINAL POSITION AFTER ASSEMBLING OR WIRING

There are parts which use the insulation material such as a tube or tape for safety, or which are assembled in the condition that these do not contact with the printed board. The inside wiring is designed not to get closer to the pyrogenic parts and high voltage parts. Therefore, put these parts in the original positions.

5. TAKE CARE TO DEAL WITH THE CATHODE-RAY TUBE

In the condition that an explosion-proof cathode-ray tube is set in this equipment, safety is secured against implosion. However, when removing it or serving from backward, it is dangerous to give a shock. Take enough care to deal with it.

6. AVOID AN X-RAY

Safety is secured against an X-ray by considering about the cathode-ray tube and the high voltage peripheral circuit, etc.

Therefore, when repairing the high voltage peripheral circuit, use the designated parts and make sure not modify the circuit.

Repairing except indicates causes rising of high voltage, and it emits an X-ray from the cathode-ray tube.

7. PERFORM A SAFETY CHECK AFTER SERVICING

Confirm that the screws, parts and wiring which were removed in order to service are put in the original positions, or whether there are the portions which are deteriorated around the serviced places serviced or not. Check the insulation between the antenna terminal or external metal and the AC cord plug blades. And be sure the safety of that.

(INSULATION CHECK PROCEDURE)

1. Unplug the plug from the AC outlet.
2. Remove the antenna terminal on TV and turn on the TV.
3. Insulation resistance between the cord plug terminals and the external exposure metal **[Note 2]** should be more than 1M ohm by using the 500V insulation resistance meter **[Note 1]**.
4. If the insulation resistance is less than 1M ohm, the inspection repair should be required.

[Note 1]

If you have not the 500V insulation resistance meter, use a Tester.

[Note 2]

External exposure metal: Antenna terminal
Headphone jack

HOW TO ORDER PARTS

Please include the following informations when you order parts. (Particularly the VERSION LETTER.)

1. MODEL NUMBER and VERSION LETTER

The MODEL NUMBER can be found on the back of each product and the VERSION LETTER can be found at the end of the SERIAL NUMBER.

2. PART NO. and DESCRIPTION

You can find it in your SERVICE MANUAL.

IMPORTANT

When you exchange IC and Transistor with a heat sink, apply silicon grease on the contact section of the heat sink. Before applying new silicon grease, remove all the old silicon grease. (Old grease may cause damages to the IC and Transistor.)



Licensed by BBE Sound, Inc. under USP5510752 and 5736897.
BBE and BBE symbol are registered trademarks of BBE Sound, Inc.

TABLE OF CONTENTS

GREEN PRODUCT PROCUREMENT	A1-1
LEAD-FREE SOLDER	A1-1
SERVICING NOTICES ON CHECKING	A1-2
HOW TO ORDER PARTS	A1-2
IMPORTANT	A1-2
TABLE OF CONTENTS	A2-1
GENERAL SPECIFICATIONS	A3-1~A3-5
DISASSEMBLY INSTRUCTIONS	
1. REMOVAL OF ANODE CAP	B1-1
2. REMOVAL AND INSTALLATION OF FLAT PACKAGE IC	B2-1, B2-2
SERVICE MODE LIST	C-1
CONFIRMATION OF HOURS USED	C-1
WHEN REPLACING EEPROM (MEMORY) IC	C-1
ELECTRICAL ADJUSTMENTS	D-1~D-6
BLOCK DIAGRAMS	E-1, E-2
PRINTED CIRCUIT BOARDS	
MAIN	F-1~F-4
CRT/VM COIL/POWER	F-5, F-6
SCHEMATIC DIAGRAMS	
MICON	G-1, G-2
CHROMA	G-3, G-4
DEFLECTION	G-5, G-6
POWER	G-7, G-8
SOUND	G-9, G-10
TUNER/STEREO	G-11, G-12
AV	G-13, G-14
COMB/FILTER	G-15, G-16
CRT/SVM	G-17, G-18
SUB POWER	G-19, G-20
WAVEFORMS	H-1, H-2
MECHANICAL EXPLODED VIEWS	I-1, I-2
MECHANICAL REPLACEMENT PARTS LIST	J1-1
ELECTRICAL REPLACEMENT PARTS LIST	J2-1~J2-5

GENERAL SPECIFICATIONS

G-1	TV System	CRT	CRT Size / Visual Size	27 inch / 676.0mmV	
			CRT Type	Flat	
			Deflection	106 degree	
			Magnetic Field BV/BH	+0.45G/0.18G	
			Color System	NTSC	
			Speaker	2 Speaker	
				Position	Front Side
				Size	1.8 x 3.9 Inch
				Impedance	8 ohm
			Sound Output	MAX	5.0+5.0 W
		10%(Typical)	4.0+4.0 W		
		NTSC3.58+4.43 /PAL60Hz	No		
G-2	Tuning System	Broadcasting System		US System M	
		Tuner and Receive CH	System	1Tuner	
			Destination	USA(W/ CATV)	
			Tuning System	F-Synth	
			Input Impedance	VHF/UHF 75 ohm	
				CH Coverage	2 - 69, 4A, A-5 - A-1, A - I, J - W, W+1 - W+84
			Intermediate Frequency	Picture(FP)	45.75MHz
				Sound(FS)	41.25MHz
				FP-FS	4.50MHz
			Preset CH		No
	Stereo/Dual TV Sound		Yes		
	Tuner Sound Muting		Yes		
G-3	Power	Power Source	AC	120V AC 60Hz	
			DC		
		Power Consumption		at AC	
			Stand by (at AC) Per Year		135 W at AC 120 V 60 Hz 3 W at AC 120 V 60 Hz -- kWh/Year
		Protector	Power Fuse		Yes
	Safety Circuit		Yes		
	IC Protector(Micro Fuse)		No		
G-4	Regulation	Safety		CSA	
		Radiation		IC	
		X-Radiation		HWC	
G-5	Temperature	Operation		+5oC ~ +40oC	
		Storage		-20oC ~ +60oC	
G-6	Operating Humidity			Less than 80% RH	

GENERAL SPECIFICATIONS

G-7	On Screen Display	Menu		Yes	
		Menu Type		Icon	
		Picture		Yes	
				Contrast	Yes
				Brightness	Yes
				Color	Yes
				Tint	Yes
				Sharpness	Yes
			Sound		Yes
				Bass	Yes
				Treble	Yes
				Balance	Yes
				BBE On/Off	Yes
				Stable Sound On/Off	Yes
				Surround On/Off	Yes
			Set Up		Yes
				TV/CATV	Yes
				Auto CH Memory	Yes
				Add/ Delete	Yes
			Option		Yes
				Language	Yes
				CH Label	Yes
				Favorite CH	Yes
				V-Chip	No
				Lock	Yes
				On/Off Timer	Yes
				Color Stream DVD/DTV	Yes
			Control Level		Yes
				Volume	Yes
				Brightness	Yes
				Contrast	Yes
				Color	Yes
				Tint	Yes
		Sharpness	Yes		
		Tuning	No		
		Bass	Yes		
		Treble	Yes		
		Balance	Yes		
		Back Light	No		
		Stereo,Audio Output,SAP	Yes		
		Video	Yes		
		Color Stream	Yes		
		Channel(TV/Cable)	Yes		
		CH Label	Yes		
		Game Timer	Yes		
		Sleep Timer	Yes		
		Sound Mute	Yes		
		V-chip Rating	No		
		16: 9	Yes		
G-8	OSD Language		English French Spanish		
G-9	Clock and Timer	Sleep Timer	Max Time	120 Min	
			Step	<u> </u> 10 <u> </u> Min	
		On/Off Timer	Program(On Timer / Off Timer)	Yes	
		Wake Up Timer		No	
	Timer Back-up (at Power Off Mode)	more than	-- Min Sec		

GENERAL SPECIFICATIONS

G-10	Remote Control	Unit	RC-GW		
		Glow in Dark Remocon	Yes		
		Format	Toshiba		
		Custom Code	TV:40-BF h		
		Power Source	Voltage(D.C) UM size x pcs	3V UM-4 x 2 pcs	
		Total Keys		50 Keys	
		Keys	Power	Yes	
			1	Yes	
			2	Yes	
			3	Yes	
			4	Yes	
			5	Yes	
			6	Yes	
			7	Yes	
			8	Yes	
			9	Yes	
			0	Yes	
			100	Yes	
			CH Up	Yes	
			CH Down	Yes	
			Volume Up	Yes	
			Volume Down	Yes	
			TV/Caption/Text	Yes	
			CH1/CH2	Yes	
			TV/Video(TV/AV)	Yes	
			CH RTN/CH ENT(Quick View)	Yes	
			Sleep	Yes	
			RE Call(Call)	Yes	
			Reset	Yes	
			Menu/Enter	Yes	
			Mute	Yes	
			Exit	Yes	
			MTS(Audio Select)	Yes	
			Fav.Up	Yes	
			Fav.Down	Yes	
			16: 9	Yes	
			Multi Brand Keys	CH Up(VCR)	Yes
				CH Down(VCR)	Yes
				Pause/Still	Yes
				TV/VCR(VCR)	Yes
				FF	Yes
				Rew	Yes
				Rec	Yes
				Play	Yes
				Stop	Yes
				TV	Yes
				VCR	Yes
				Cable	Yes
				DVD	Yes
				CODE	Yes
Volume Up(DVD)	Yes				
Volume Down(DVD)	Yes				
DVD CLEAR	Yes				
TOP MENU	Yes				
DVD MENU	Yes				
DISPLAY	Yes				

GENERAL SPECIFICATIONS

G-11	Features	Auto Degauss	Yes	
		Auto Shut Off	Yes	
		Canal+	No	
		CATV	Yes	
		Anti-theft	No	
		Rental	No	
		Memory(Last CH)	Yes	
		Memory(Last Volume)	Yes	
		V-Chip	No	
		Type		
		BBE	Yes	
		Auto Search	No	
		CH Allocation	No	
		SAP	Yes	
		Just Clock Function	No	
		CH Label	Yes	
		VM Circuit	Yes	
		Full OSD	No	
		Premiere	No	
		Comb Filter	Yes <u>3</u> Lines	
		Auto CH Memory	Yes	
		Hotel Lock	No	
		Closed Caption	Yes	
		Stable Sound	Yes	
		FBT Leak Test Protect	Yes	
		CH Lock	Yes	
		Video Lock	Yes	
		Game Timer (Max Time:120 Min)	Yes	
		Energy Star	No	
		Favorite CH	Yes	
		Surround	Yes	
		16:9 Mode	Yes	
		G-12	Accessories	Owner's Manual
Remote Control Unit				Yes
Rod Antenna	Poles Terminal			No
Loop Antenna	Terminal			No
U/V Mixer				No
DC Car Cord (Center+)				No
Guarantee Card				No
Warning Sheet				No
Circuit Diagram				No
Antenna Change Plug				No
Service Station List				No
Important Safety Instruction				No
Dew/AHC Caution Sheet				No
AC Plug Adapter				No
Quick Set-up Sheet				No
Battery	UM size x pcs OEM Brand			Yes UM-4 x 2 No
AC Cord				No
AV Cord (2Pin-1Pin)				No
Registration Card (NDL Card)				No
PTB Sheet				No
ESP Card				No
300 ohm to 75 ohm Antenna Adapter				No

GENERAL SPECIFICATIONS

G-13	Interface	Switch	Front	Power	Yes
				System Select	No
				Main Power SW	No
				Sub Power	No
				Channel Up	Yes
				Channel Down	Yes
				Volume Up	Yes
				Volume Down	Yes
				Rear	AC/DC
		TV/CATV Selector	No		
		Degauss	No		
		Main Power SW	No		
		Indicator	Power	Yes(RED)	
			Stand-by	No	
			On Timer	No	
		Terminals	Front	Video Input = VIDEO3	RCA
				Audio Input = VIDEO3	RCA x 2(L/MONO,R)
				Other Terminal	Head Phone
			Rear	Video Input(Rear1) = VIDEO1	RCA
				Video Input(Rear2) = VIDEO2	RCA
				Audio Input(Rear1) = VIDEO1	RCA x 2(L/MONO,R)
				Audio Input(Rear2) = VIDEO2	RCA x 2(L/MONO,R)
				Video Output	RCA
				Audio Output	RCA x 2(L/MONO,R)
				Euro Scart	No
				Color Stream	RCA x 3
				S Input	Yes
Diversity	No				
Ext Speaker	No				
DC Jack 12V(Center +)	No				
VHF/UHF Antenna Input	F Type				
AC Outlet	No				
G-14	Set Size	Approx. W x D x H (mm)		<u>740</u> x <u>495</u> x <u>574.5</u>	
G-15	Weight	Net (Approx.)		<u>40.0 kg</u> (<u>88.2lbs</u>)	
		Gross (Approx.)		<u>46.5 kg</u> (<u>102.5lbs</u>)	
G-16	Carton	Master Carton		No	
			Content	--- Sets	
			Material	-- /--	
			Dimensions W x D x H(mm)	-- x -- x --	
			Description of Origin	No	
		Gift Box	Material	Double/Brown	
			Dimensions W x D x H(mm)	<u>850</u> x <u>620</u> x <u>665</u>	
			Description of Origin	Yes	
		Drop Test		Natural Dropping At 1 Corner / 2 Edges / 4 Surfaces	
			Height (cm)	40 (ORION SPEC:25)	
	Container Stuffing	<u>156</u> Sets/40' container			
G-17	Cabinet Material	Cabinet	Cabinet Front	PS 94V0 DECABROM	
			Cabinet Rear	PS 94V0 DECABROM	
		PCB	Non-Halogen Demand	No	
			Eyelet Demand	Yes	
G-18	Environment	Environmental standard requirement	Green procurement of TOSHIBA		
		Pb-free	Phase3(Phase3A)		

DISASSEMBLY INSTRUCTIONS

1. REMOVAL OF ANODE CAP

Read the following **NOTED** items before starting work.

- * After turning the power off there might still be a potential voltage that is very dangerous. When removing the Anode Cap, make sure to discharge the Anode Cap's potential voltage.
- * Do not use pliers to loosen or tighten the Anode Cap terminal, this may cause the spring to be damaged.

REMOVAL

1. Follow the steps as follows to discharge the Anode Cap. (Refer to Fig. 1-1.)

Connect one end of an Alligator Clip to the metal part of a flat-blade screwdriver and the other end to ground. While holding the plastic part of the insulated Screwdriver, touch the support of the Anode with the tip of the Screwdriver. A cracking noise will be heard as the voltage is discharged.

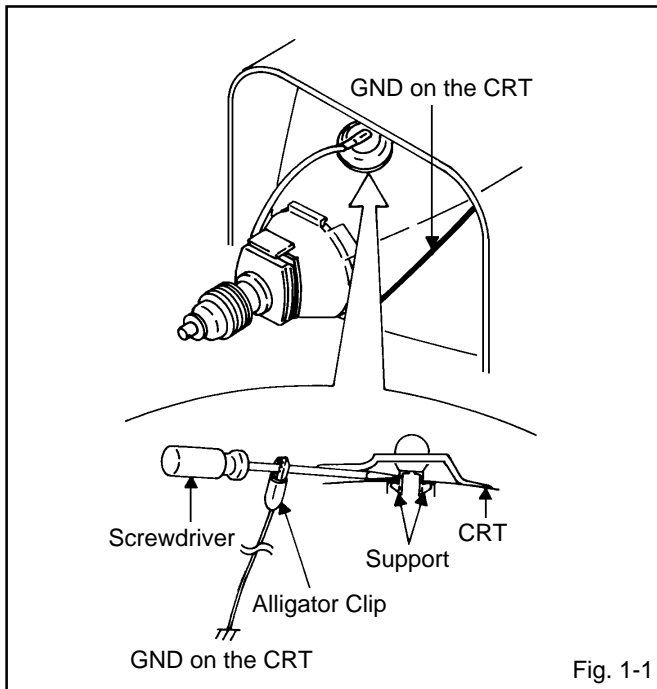

2. Flip up the sides of the Rubber Cap in the direction of the arrow and remove one side of the support. (Refer to Fig. 1-2.)

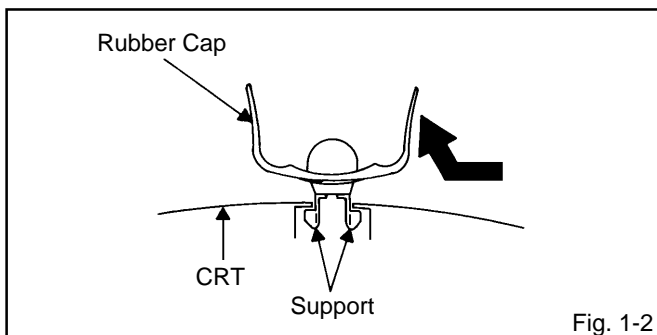

3. After one side is removed, pull in the opposite direction to remove the other.

NOTE

Take care not to damage the Rubber Cap.

INSTALLATION

1. Clean the spot where the cap was located with a small amount of alcohol. (Refer to Fig. 1-3.)



NOTE

Confirm that there is no dirt, dust, etc. at the spot where the cap was located.

2. Arrange the wire of the Anode Cap and make sure the wire is not twisted.
3. Turn over the Rubber Cap. (Refer to Fig. 1-4.)

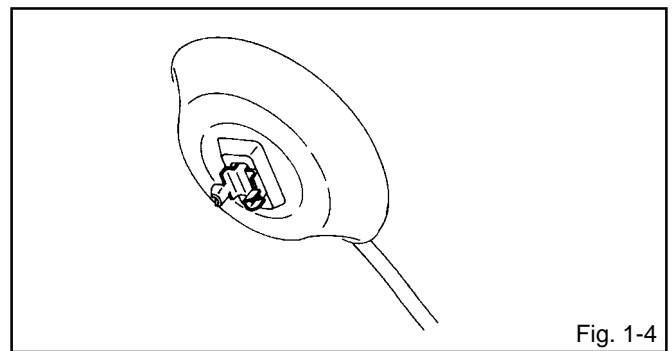

4. Insert one end of the Anode Support into the anode button, then the other as shown in Fig. 1-5.

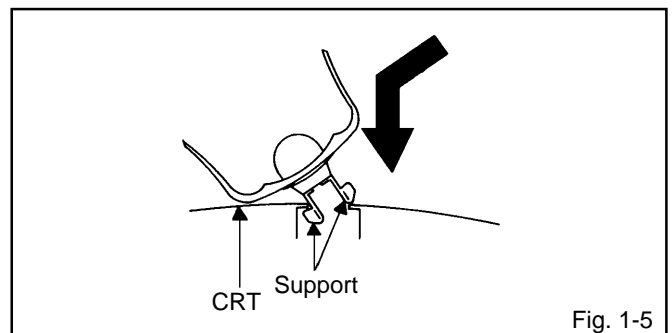

5. Confirm that the Support is securely connected.
6. Put on the Rubber Cap without moving any parts.

DISASSEMBLY INSTRUCTIONS

2. REMOVAL AND INSTALLATION OF FLAT PACKAGE IC

REMOVAL

1. Put the Masking Tape (cotton tape) around the Flat Package IC to protect other parts from any damage. (Refer to Fig. 2-1.)

NOTE

Masking is carried out on all the parts located within 10 mm distance from IC leads.

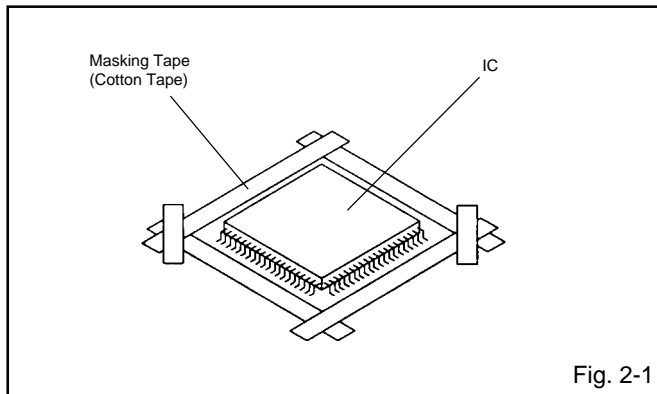

2. Heat the IC leads using a blower type IC desoldering machine. (Refer to Fig. 2-2.)

NOTE

Do not add the rotating and the back and forth directions force on the IC, until IC can move back and forth easily after desoldering the IC leads completely.

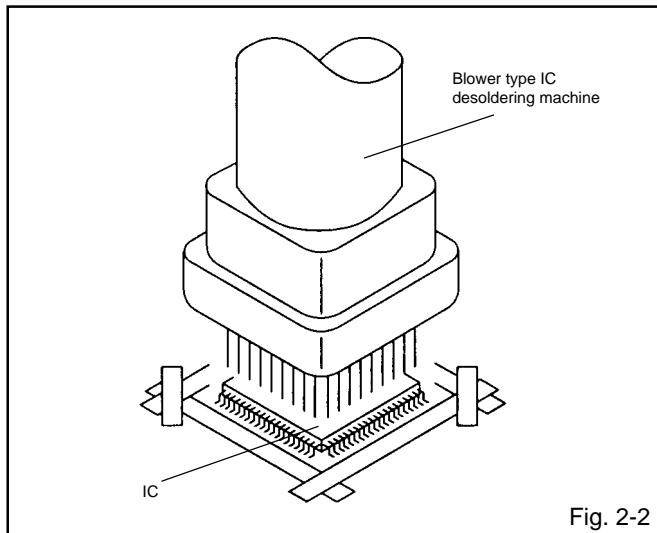

3. When IC starts moving back and forth easily after desoldering completely, pickup the corner of the IC using a tweezers and remove the IC by moving with the IC desoldering machine. (Refer to Fig. 2-3.)

NOTE

Some ICs on the PCB are affixed with glue, so be careful not to break or damage the foil of each IC leads or solder lands under the IC when removing it.

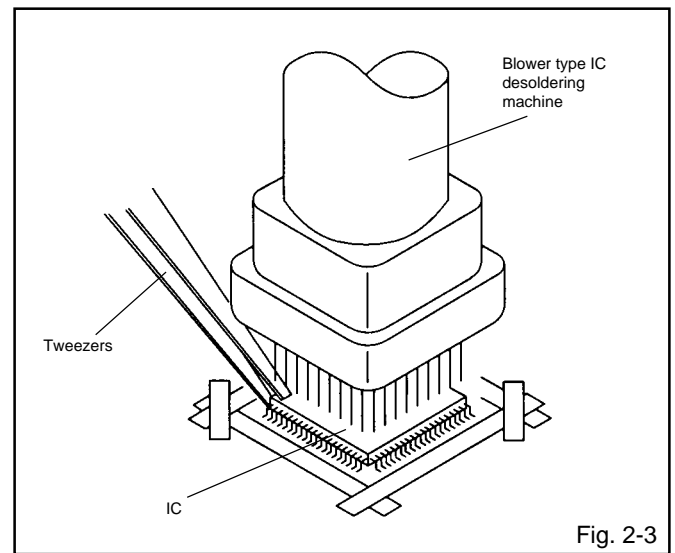

4. Peel off the Masking Tape.

5. Absorb the solder left on the pattern using the Braided Shield Wire. (Refer to Fig. 2-4.)

NOTE

Do not move the Braided Shield Wire in the vertical direction towards the IC pattern.

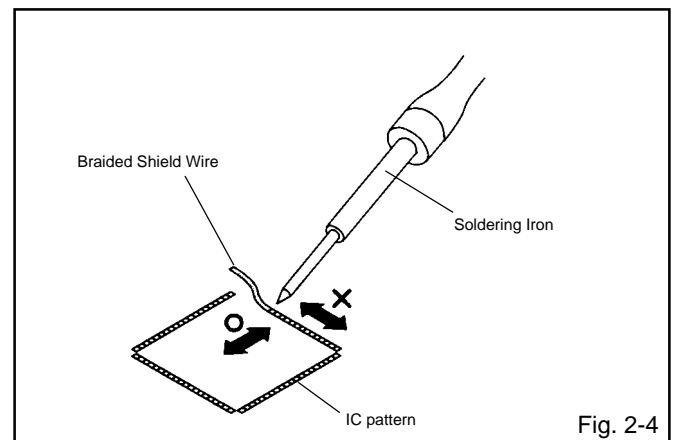

DISASSEMBLY INSTRUCTIONS

INSTALLATION

1. Take care of the polarity of new IC and then install the new IC fitting on the printed circuit pattern. Then solder each lead on the diagonal positions of IC temporarily. (Refer to Fig. 2-5.)

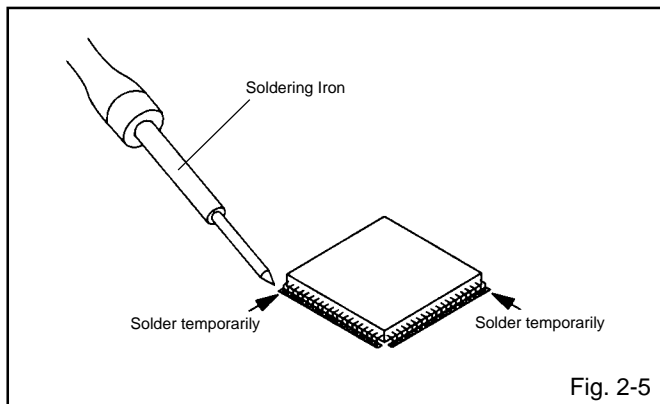

2. Supply the solder from the upper position of IC leads sliding to the lower position of the IC leads. (Refer to Fig. 2-6.)

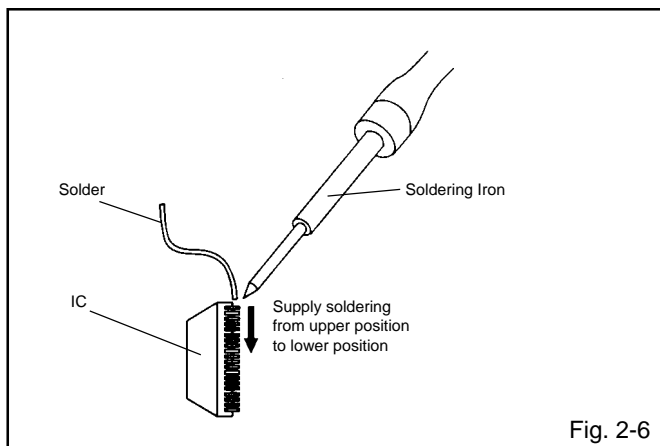

3. Absorb the solder left on the lead using the Braided Shield Wire. (Refer to Fig. 2-7.)

NOTE

Do not absorb the solder to excess.

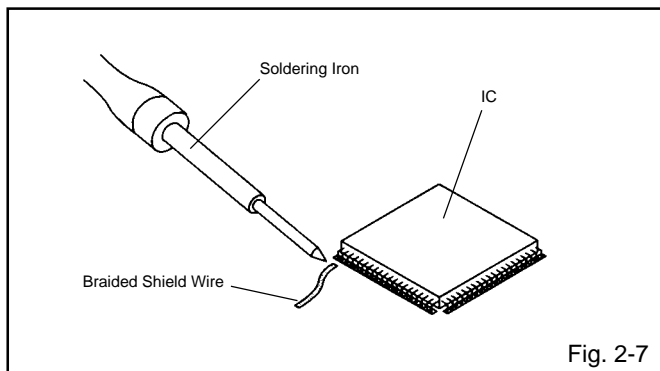

4. When bridge-soldering between terminals and/or the soldering amount are not enough, resolder using a Thin-tip Soldering Iron. (Refer to Fig. 2-8.)

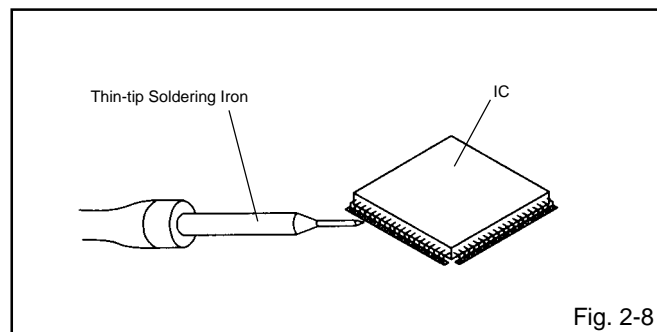

5. Finally, confirm the soldering status on four sides of the IC using a magnifying glass. Confirm that no abnormality is found on the soldering position and installation position of the parts around the IC. If some abnormality is found, correct by resoldering.

NOTE

When the IC leads are bent during soldering and/or repairing, do not repair the bending of leads. If the bending of leads are repaired, the pattern may be damaged. So, always be sure to replace the IC in this case.

SERVICE MODE LIST

This unit is provided with the following SERVICE MODES so you can repair, examine and adjust easily. To enter to the Service Mode, press both set key and remote control key for more than 1 second.

Set Key	Remocon Key	Operations
VOL. (-) MIN	0	Releasing of V-CHIP PASSWORD and LOCK PASSWORD.
VOL. (-) MIN	1	Initialization of factory data. NOTE: Do not use this for normal servicing. If you set factory initialization, the memories are reset such as the clock setting, the channel setting, the POWER ON total hours, and PLAY/REC total hours.
VOL. (-) MIN	6	POWER ON total hours is displayed on the screen. Refer to the "CONFIRMATION OF HOURS USED". Can be checked of the INITIAL DATA of MEMORY IC. Refer to the "WHEN REPLACING EEPROM (MEMORY) IC".
VOL. (-) MIN	9	Display of the Adjustment MENU on the screen. Refer to the "ELECTRICAL ADJUSTMENT" (On-Screen Display Adjustment).

CONFIRMATION OF HOURS USED

POWER ON total hours can be checked on the screen. Total hours are displayed in 16 system of notation.

NOTE: If you set factory initialization, the total hours is reset to "0".

1. Set the VOLUME to minimum.
2. Press both VOL. DOWN button on the set and Channel button **(6)** on the remote control for more than 1 second.
3. After the confirmation of using hours, turn off the power.

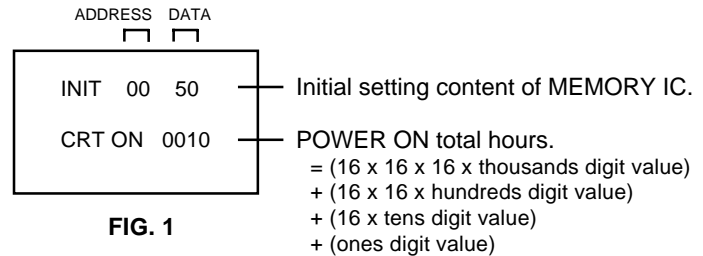

WHEN REPLACING EEPROM (MEMORY) IC

If a service repair is undertaken where it has been required to change the MEMORY IC, the following steps should be taken to ensure correct data settings while making reference to TABLE 1.

NOTE: No need to set data for after position INI 1F due to the adjustment value.

INI	+0	+1	+2	+3	+4	+5	+6	+7	+8	+9	+A	+B	+C	+D	+E	+F
00	50	E8	0A	44	5E	B3	24	B7	3C	AC	0B	04	80	80	80	59
10	70	00	00	00	03	00	06	60	3F	0F	0D	E2	A8	21	42	00

Table 1

1. Enter DATA SET mode by setting VOLUME to minimum.
 2. Press both VOL. DOWN button on the set and Channel button **(6)** on the remote control for more than 1 second. ADDRESS and DATA should appear as FIG 1.
 3. ADDRESS is now selected and should "blink". Using the VOL. UP/DOWN button on the remote, step through the ADDRESS until required ADDRESS to be changed is reached.
 4. Press ENTER to select DATA. When DATA is selected, it will "blink".
 5. Again, step through the DATA using VOL. UP/DOWN button until required DATA value has been selected.
 6. Pressing ENTER will take you back to ADDRESS for further selection if necessary.
 7. Repeat steps 3 to 6 until all data has been checked.
 8. When satisfied correct DATA has been entered, turn POWER off (return to STANDBY MODE) to finish DATA input.
After the data input, set to the initializing of shipping.
 9. Turn POWER on.
 10. Press both VOL. DOWN button on the set and Channel button **(1)** on the remote control for more than 1 second.
 11. After the finishing of the initializing of shipping, the unit will turn off automatically.
- The unit will now have the correct DATA for the new MEMORY IC.

ELECTRICAL ADJUSTMENTS

1. ADJUSTMENT PROCEDURE

Read and perform these adjustments when repairing the circuits or replacing electrical parts or PCB assemblies.

CAUTION

- Use an isolation transformer when performing any service on this chassis.
- Before removing the anode cap, discharge electricity because it contains high voltage.
- When removing a PCB or related component, after unfastening or changing a wire, be sure to put the wire back in its original position.
- When you exchange IC and Transistor with a heat sink, apply silicon grease on the contact section of the heat sink. Before applying new silicon grease, remove all the old silicon grease. (Old grease may cause damages to the IC and Transistor.)

Prepare the following measurement tools for electrical adjustments.

1. Oscilloscope
2. Digital Voltmeter
3. Multi-sound Generator
4. Pattern Generator

On-Screen Display Adjustment

1. In the condition of NO indication on the screen.
2. Press the VOL. DOWN button on the set and the Channel button (9) on the remote control for more than 1 second to appear the adjustment mode on the screen as shown in Fig. 1-1.

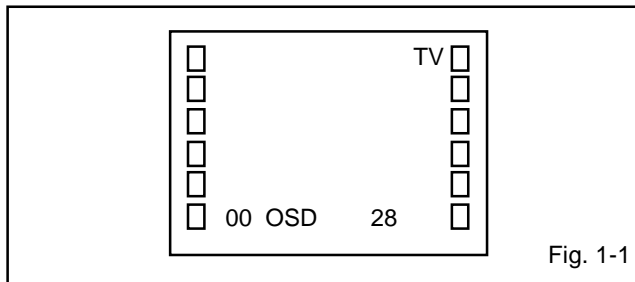

Fig. 1-1

3. Use the Channel UP/DOWN button or Channel button (0-9) on the remote control to select the options shown in Fig. 1-2.
4. Press the MENU button on the remote control to end the adjustments.

NO.	FUNCTION	NO.	FUNCTION
00	OSD H	18	CONTRAST MAX
01	CUT OFF	19	CONTRAST CENT
02	H. VCO	20	CONTRAST MIN
03	H. PHASE	21	COLOR MAX
04	AFC GAIN	22	COLOR CENTER
05	V. SHIFT	23	COLOR MIN
06	H. SIZE	24	TINT
07	V. SIZE	25	SHARPNESS
08	V. LINERITY	26	CB DL
09	VS CORRECTION	27	CR DL
10	R DRIVE	28	CB PED
11	B DRIVE	29	CR PED
12	R BIAS	30	PARABOLA
13	G BIAS	31	CORNER
14	B BIAS	32	TRAPWZIUM
15	BRIGHT MAX	33	LEVEL
16	BRIGHT CENT	34	SEPARATION1
17	BRIGHT MIN	35	SEPARATION2

Fig. 1-2

2. BASIC ADJUSTMENTS

2-1: CONSTANT VOLTAGE

1. Place the set in AV MODE without signal.
2. Connect the digital voltmeter to the TP003.
3. Adjust the VR502 until the digital voltmeter is $135 \pm 0.5V$.

2-2: CUT OFF

1. Place the set in Aging Test for more than 15 minutes.
2. Place the set in AV MODE without signal.
3. Using the remote control, set the brightness and contrast to normal position.
4. Activate the adjustment mode display of Fig. 1-1 and press the channel button (01) on the remote control to select "CUT OFF".
5. Adjust the Screen Volume until a dim raster is obtained.

2-3: WHITE BALANCE, WHITE BALANCE CS

NOTE: Adjust after performing CUT OFF adjustment.

1. Place the set in Aging Test for more than 15 minutes.
2. Receive the gray scale pattern from the Pattern Generator with Brust On.
3. Using the remote control, set the brightness and contrast to normal position.
4. Activate the adjustment mode display of Fig. 1-1 and press the channel button (12) on the remote control to select "R. BIAS".
5. Press the CH. UP/DOWN button on the remote control to select the "R. BIAS", "G. BIAS", "B. BIAS", "B. DRIVE" or "R. DRIVE".
6. Adjust the VOL. UP/DOWN button on the remote control to whiten the R. BIAS, G. BIAS, B. BIAS, B. DRIVE and R. DRIVE at each step tone sections equally.
7. Perform the above adjustments 5 and 6 until the white color is achieved.
8. Press the TV/VIDEO button on the remote control to set to the CS mode.
9. Receive the gray scale pattern from the Pattern Generator with Brust On.
10. If the picture is too much green. Activate the adjustment mode display of Fig. 1-1 and press the channel button (28) on the remote control to select "CB PED".
11. Adjust the VOL. UP/DOWN button on the remote control to select the step up.
12. If the picture is too much red. Activate the adjustment mode display of Fig. 1-1 and press the channel button (29) on the remote control to select "CR PED".
13. Adjust the VOL. UP/DOWN button on the remote control to select the step down.

ELECTRICAL ADJUSTMENTS

2-4: COLOR CENT

1. Receive the color bar pattern. (RF Input)
2. Using the remote control, set the brightness, contrast, color and tint to normal position.
3. Connect the oscilloscope to **TP804**.
4. Activate the adjustment mode display of **Fig. 1-1** and press the channel button **(22)** on the remote control to select "COLOR CENT".
5. Adjust the VOLTS RANGE VARIABLE knob of the oscilloscope until the range between white 100% and 0% is set to 4 scales on the screen of the oscilloscope.
6. Press the VOL. UP/DOWN button on the remote control until the red color level is adjusted to $125 \pm 5\%$ of the white level. (**Refer to Fig. 2-1**)
7. Receive the video color bar pattern. (Audio Video Input)
8. Set to the AV mode. Then perform the above adjustments 2~6.
9. Press the TV/VIDEO button on the remote control to set to the CS mode. Then perform the above adjustments 2~4.
10. Press the VOL. UP/DOWN button on the remote control until the color step No. becomes "70".

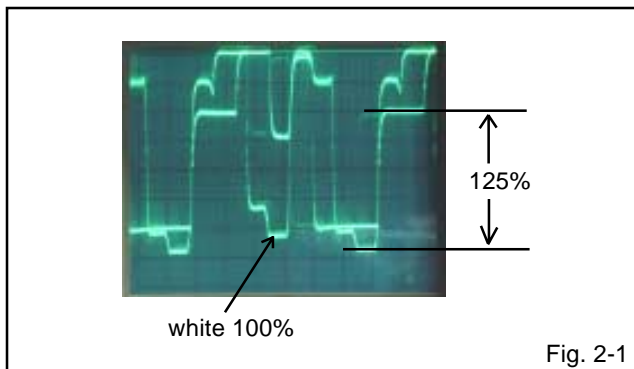

2-5: TINT

1. Receive the color bar pattern. (RF Input)
2. Using the remote control, set the brightness, contrast, color and tint to normal position.
3. Connect the oscilloscope to **TP806**.
4. Activate the adjustment mode display of **Fig. 1-1** and press the channel button **(24)** on the remote control to select "TINT".
5. Press the VOL. UP/DOWN button on the remote control until the section "A" becomes as straight line. (**Refer to Fig. 2-2**)
6. Receive the video color bar pattern. (Audio Video Input)
7. Set to the AV mode. Then perform the above adjustments 2~5.
8. Press the TV/VIDEO button on the remote control to set to the CS mode. Then perform the above adjustments 2~4.
9. Press the VOL. UP/DOWN button on the remote control until the tint step No. becomes "55".

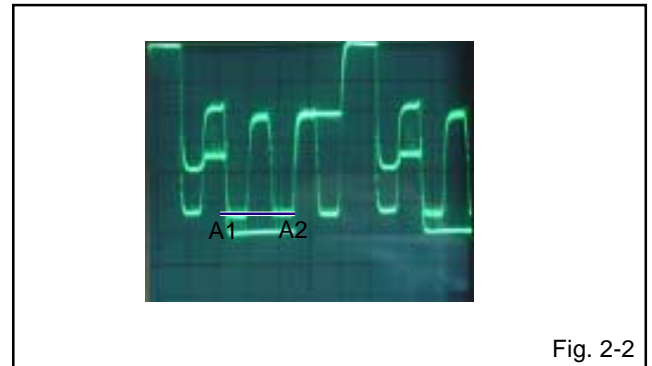

2-6: FOCUS

1. Receive the monoscope pattern.
2. Turn the Focus Volume fully counterclockwise once.
3. Adjust the **Focus Volume** until picture is distinct.

2-7: VERTICAL POSITION

1. Receive the monoscope pattern.
2. Using the remote control, set the brightness and contrast to normal position.
3. Adjust the **VR401** until the horizontal line becomes fit to the notch of the shadow mask. (**Refer to Fig. 2-3**)

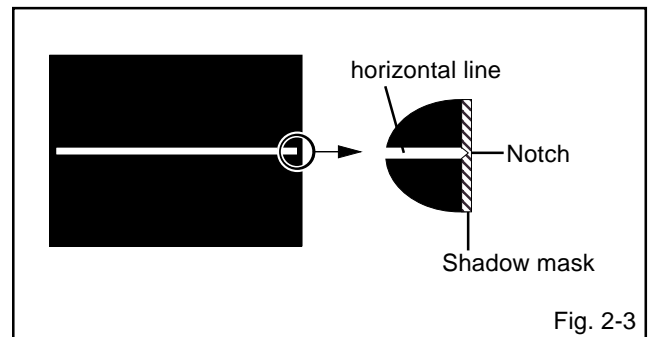

2-8: VERTICAL SIZE

1. Receive the monoscope pattern.
2. Using the remote control, set the brightness and contrast to normal position.
3. Activate the adjustment mode display of **Fig. 1-1** and press the channel button **(07)** on the remote control to select "V. SIZE".
4. Press the VOL. UP/DOWN button on the remote control until the SHIFT quantity of the OVER SCAN on upside and downside becomes $9 \pm 3\%$.

ELECTRICAL ADJUSTMENTS

2-9: VERTICAL LINEARITY

NOTE: Adjust after performing adjustments in section 2-8. After the adjustment of Vertical Linearity, reconfirm the Vertical Position and Vertical Size adjustments.

1. Receive the monoscope pattern.
2. Using the remote control, set the brightness, contrast, to normal position.
3. Activate the adjustment mode display of **Fig. 1-1** and press the channel button **(08)** on the remote control to select "V. LINEARITY".
4. Press the VOL. UP/DOWN button on the remote control until the SHIFT quantity of the OVER SCAN on upside and downside becomes minimum.

2-10: HORIZONTAL POSITION

1. Receive the monoscope pattern.
2. Using the remote control, set the brightness, contrast, to normal position.
3. Activate the adjustment mode display of **Fig. 1-1** and press the channel button **(03)** on the remote control to select "H.PHASE".
4. Press the VOL. UP/DOWN button on the remote control until the SHIFT quantity of the OVER SCAN on right and left becomes minimum.

2-11: HORIZONTAL SIZE

1. Receive the monoscope pattern.
2. Using the remote control, set the brightness and contrast to normal position.
3. Activate the adjustment mode display of **Fig. 1-1** and press the channel button **(06)** on the remote control to select "H. SIZE".
4. Press the VOL. UP/DOWN button on the remote control adjust the H.SIZE becomes 10~12%.

2-12: OSD POSITION

1. Activate the adjustment mode display of **Fig. 1-1**.
2. Press the VOL. UP/DOWN button on the remote control until the difference of A and B becomes minimum. (**Refer to Fig. 2-4**)

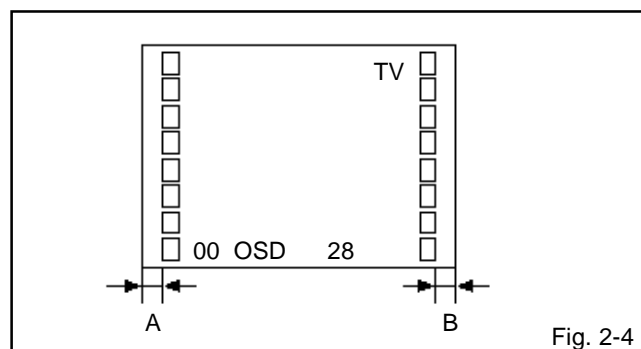

2-13: BRIGHT CENT

1. Receive the monoscope pattern. (RF Input)
2. Using the remote control, set the brightness and contrast to normal position.
3. Activate the adjustment mode display of **Fig. 1-1** and press the channel button **(16)** on the remote control to select "BRI CENT".
4. Press the VOL. UP/DOWN button on the remote control until the screen begin to shine.
5. Receive the monoscope pattern. (Audio Video Input)
6. Press the TV/VIDEO button on the remote control to set to the AV mode. Then perform the above adjustments 2~4.
7. Press the TV/VIDEO button on the remote control to set to the CS mode.
8. Activate the adjustment mode display of **Fig. 1-1** and press the channel button **(16)** on the remote control to select "BRI CENT".
9. Press the VOL. UP/DOWN button on the remote control until the brightness step No. becomes "100".

2-14: CONTRAST MAX

1. Activate the adjustment mode display of **Fig. 1-1** and press the channel button **(18)** on the remote control to select "CONT. MAX".
2. Press the VOL. UP/DOWN button on the remote control until the contrast step No. becomes "85".
3. Receive a broadcast and check if the picture is normal.
4. Press the TV/VIDEO button on the remote control to set to the AV mode. Then perform the above adjustments 1~3.
5. Press the TV/VIDEO button on the remote control to set to the CS mode. Then perform the above adjustments 1~3.

2-15: PARABOLA/CORNER

1. Receive the cross hatch signal from the Pattern Generator.
2. Using the remote control, set the brightness and contrast to normal position.
3. Activate the adjustment mode display of **Fig. 1-1** and press the channel button **(30)** on the remote control to select "PARABOLA".
4. Press the VOL. UP/DOWN button on the remote control until the right and left vertical lines are straight.
5. In the case the right and left vertical lines are not straight, Please Activate the adjustment mode display of **Fig. 1-1** and press the channel button **(31)** on the remote control to select "CORNER".
6. Press the VOL. UP/DOWN button on the remote control until the right and left vertical lines are straight.

2-16: TRAPEZIUM

1. Receive the cross hatch signal from the Pattern Generator.
2. Using the remote control, set the brightness and contrast to normal position.
3. Activate the adjustment mode display of **Fig. 1-1** and press the channel button **(32)** on the remote control to select "TRAPEZIUM".
4. Press the VOL. UP/DOWN button on the remote control until the both vertical lines of the screen become paralld.

ELECTRICAL ADJUSTMENTS

2-17: SEPARATION 1, 2

Please do the method (1) or method (2) adjustment.

Method (1)

1. Set the multi-sound signal generator for each different L-ch and R-ch frequency (Ex. L-ch=2KHz, R-ch=400Hz) and receive the RF.
2. Connect the oscilloscope to the Audio Out Jack.
3. Activate the adjustment mode display of **Fig. 1-1** and press the channel button (34) on the remote control to select "SEP 1".
4. Press the VOL. UP/DOWN button on the remote control to adjust it until the audio output wave becomes a fine sine wave.
5. Press the CH UP button once the set to "SEP 2" mode. Then perform the above adjustment 4.

Method (2)

1. Set the multi-sound signal generator L-ch=1KHz, R-ch=Non input and receive the RF.
2. Connect the oscilloscope to the **Audio Out Jack (R-ch)**.
3. Press the AUDIO SELECT button on the remote control to set to the stereo mode.
4. Activate the adjustment mode display of **Fig. 1-1** and press the channel button (34) on the remote control to select "SEP 1".
5. Press the VOL. UP/DOWN button on the remote control to adjust it until the R-ch output becomes minimum.
6. Set the multi-sound signal generator L-ch=Non input, R-ch=1KHz and receive the RF.
7. Connect the oscilloscope to the **Audio Out Jack (L-ch)**.
8. Activate the adjustment mode display of **Fig. 1-1** and press the channel button (35) on the remote control to select "SEP 2".
9. Press the VOL. UP/DOWN button on the remote control to adjust it until the L-ch output becomes minimum. The output difference of the between with Filter and without Filter should be more than 25db for both L and R.

2-18: LEVEL

1. Receive the monoscope pattern.
2. Connect the AC voltmeter to **pin 6 of CP101**.
3. Activate the adjustment mode display of **Fig. 1-1** and press the channel button (33) on the remote control to select "LEVEL".
4. Press the VOL. UP/DOWN button on the remote control until the AC voltmeter is $75 \pm 2\text{mV}$.

2-19: Confirmation of Fixed Value (Step No.)

Please check if the fixed values of the each adjustment items are set correctly referring below.

NO.	FUNCTION	RF	AV	CS
02	H.VCO	03	03	03
04	AFC GAIN	06	06	06
05	V.SHIFT	02	02	02
09	VS CORRECTION	36	36	36
15	BRI.MAX	160	160	160
17	BRI.MIN	30	30	30
19	CONT.CENT	64	64	64
20	CONT.MIN	05	05	05
21	COL.MAX	90	90	90
23	COL.MIN	00	00	00
25	SHARPNESS	40	40	40
26	CB DL	00	00	00
27	CR DL	00	00	00

ELECTRICAL ADJUSTMENTS

3. PURITY AND CONVERGENCE ADJUSTMENTS

NOTE

1. Turn the unit on and let it warm up for at least 30 minutes before performing the following adjustments.
2. Place the CRT surface facing east or west to reduce the terrestrial magnetism.
3. Turn ON the unit and demagnetize with a Degauss Coil.

3-1: STATIC CONVERGENCE (ROUGH ADJUSTMENT)

1. Tighten the screw for the magnet. Refer to the adjusted CRT for the position. **(Refer to Fig. 3-1)**
If the deflection yoke and magnet are in one body, untighten the screw for the body.
2. Receive the green raster pattern from the color bar generator.
3. Slide the deflection yoke until it touches the funnel side of the CRT.
4. Adjust center of screen to green, with red and blue on the sides, using the pair of purity magnets.
5. Switch the color bar generator from the green raster pattern to the crosshatch pattern.
6. Combine red and blue of the 3 color crosshatch pattern on the center of the screen by adjusting the pair of 4 pole magnets.
7. Combine red/blue (magenta) and green by adjusting the pair of 6 pole magnets.
8. Adjust the crosshatch pattern to change to white by repeating steps 6 and 7.

3-2: PURITY

NOTE

Adjust after performing adjustments in section 3-1.

1. Receive the green raster pattern from color bar generator.
2. Adjust the pair of purity magnets to center the color on the screen.
Adjust the pair of purity magnets so the color at the ends are equally wide.
3. Move the deflection yoke backward (to neck side) slowly, and stop it at the position when the whole screen is green.
4. Confirm red and blue color.
5. Adjust the slant of the deflection yoke while watching the screen, then tighten the fixing screw.

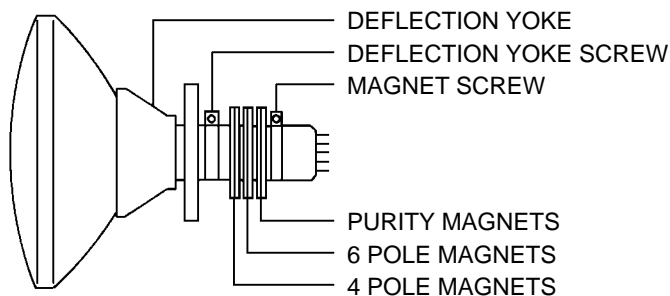

Fig. 3-1

3-3: STATIC CONVERGENCE

NOTE

Adjust after performing adjustments in section 3-2.

1. Receive the crosshatch pattern from the color bar generator.
2. Combine red and blue of the 3 color crosshatch pattern on the center of the screen by adjusting the pair of 4 pole magnets.
3. Combine red/blue (magenta) and green by adjusting the pair of 6 pole magnets.

3-4: DYNAMIC CONVERGENCE

NOTE

Adjust after performing adjustments in section 3-3.

1. Adjust the differences around the screen by moving the deflection yoke upward/downward and right/left. **(Refer to Fig. 3-2-a)**
2. Insert three wedges between the deflection yoke and CRT funnel to fix the deflection yoke. **(Refer to Fig. 3-2-b)**

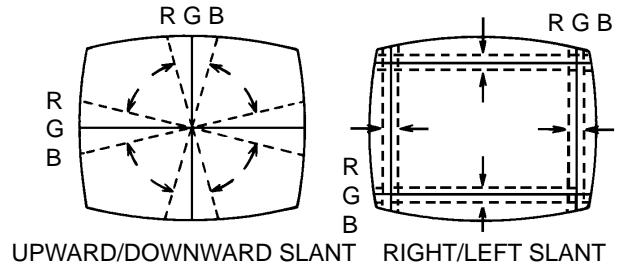
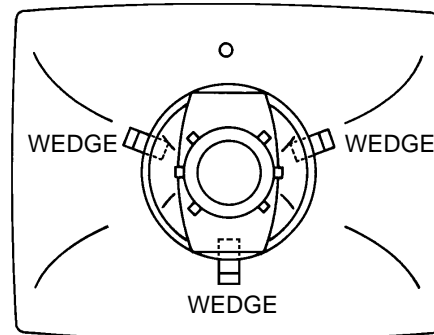

Fig. 3-2-a



WEDGE POSITION

Fig. 3-2-b

ELECTRICAL ADJUSTMENTS

4. ELECTRICAL ADJUSTMENT PARTS LOCATION GUIDE (WIRING CONNECTION)

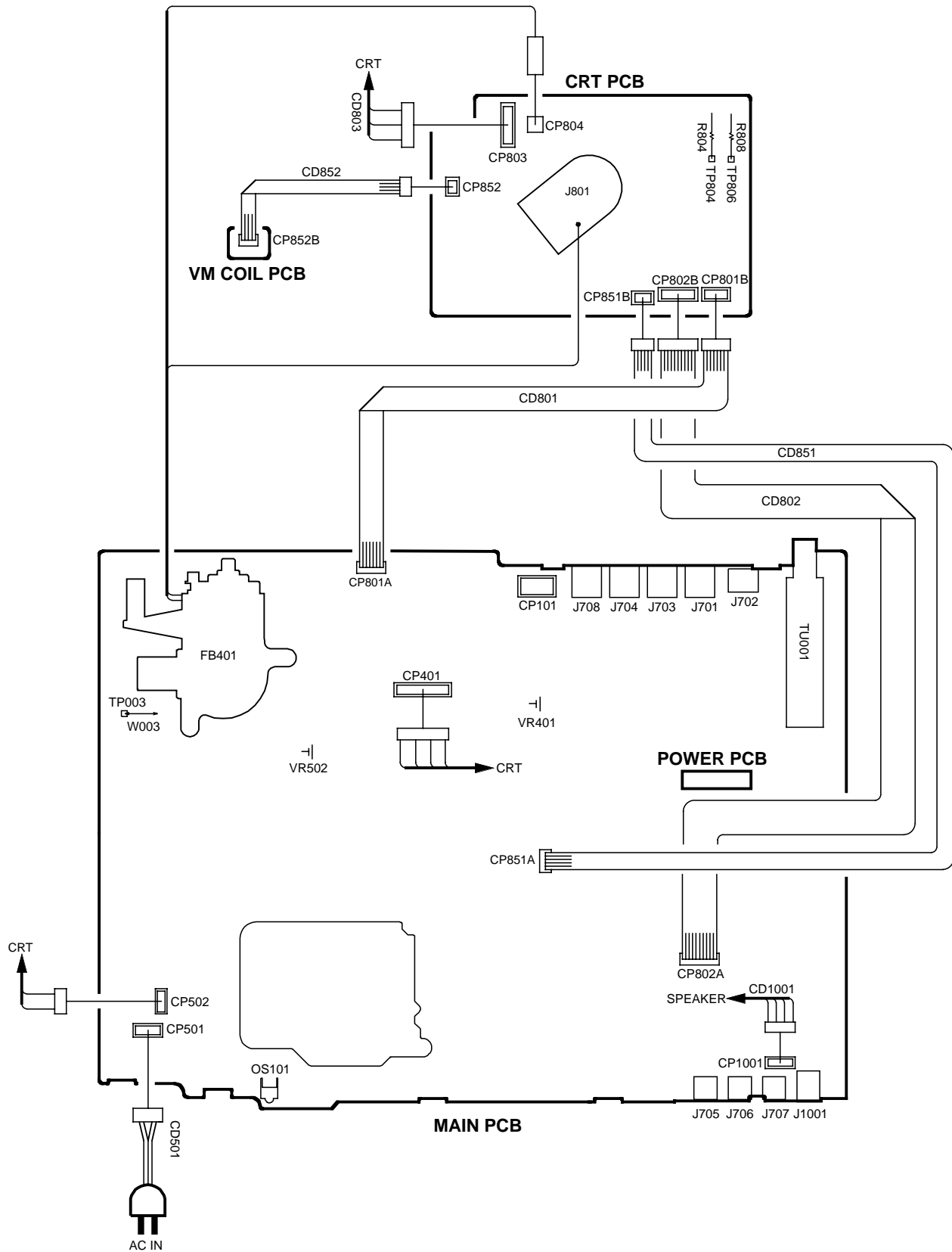

BLOCK DIAGRAM

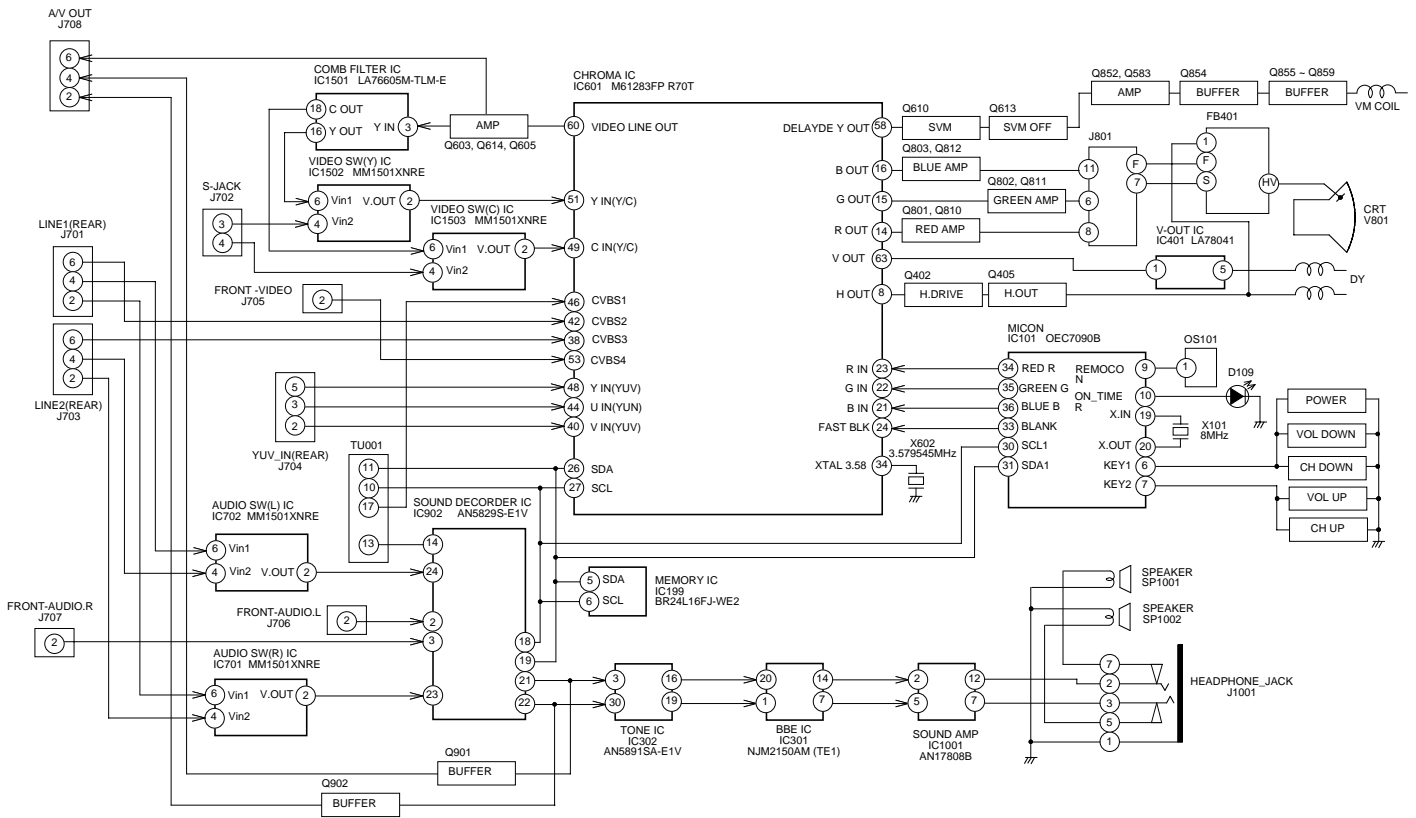

PRINTED CIRCUIT BOARDS
MAIN (INSERTED PARTS)
SOLDER SIDE

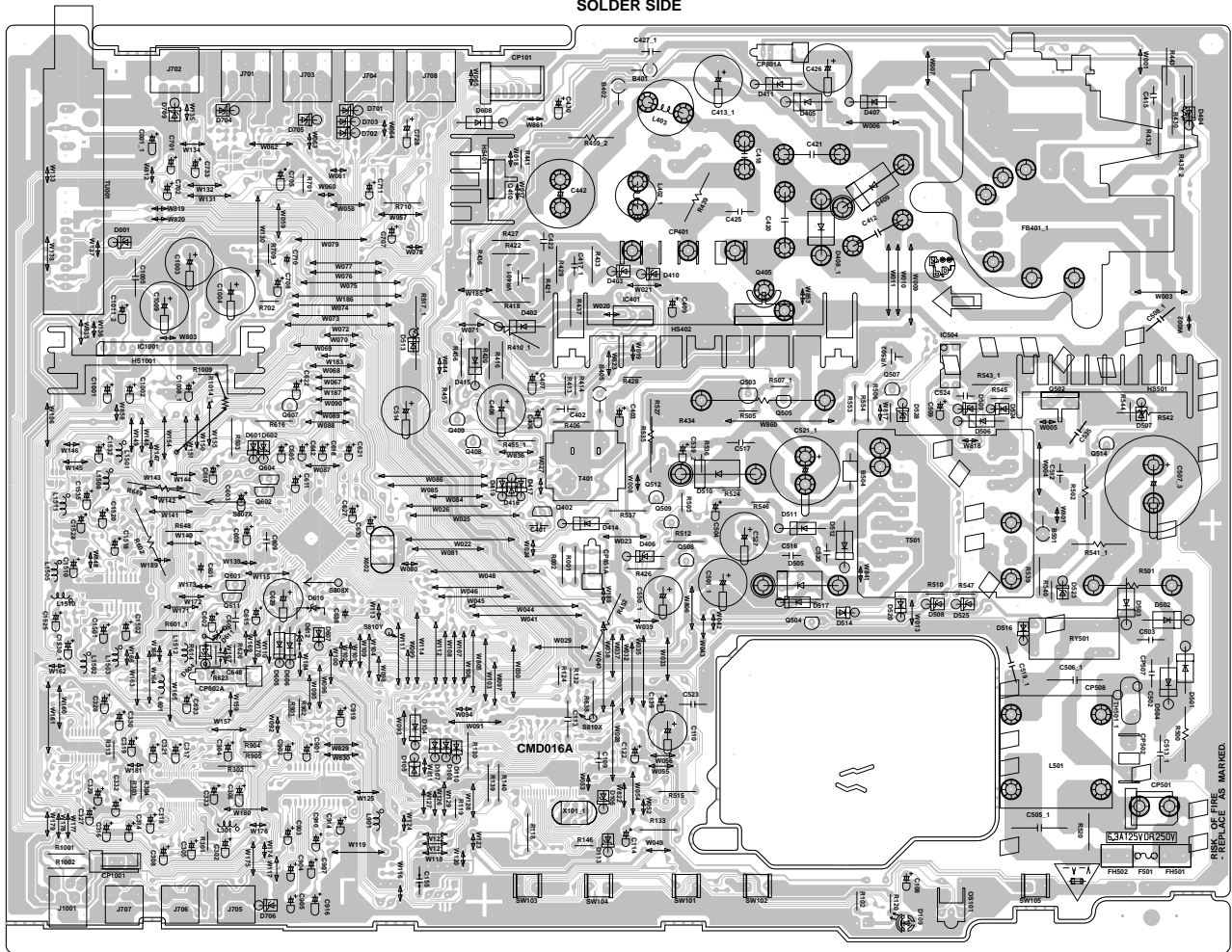

PRINTED CIRCUIT BOARDS
MAIN (CHIP MOUNTED PARTS)
SOLDER SIDE

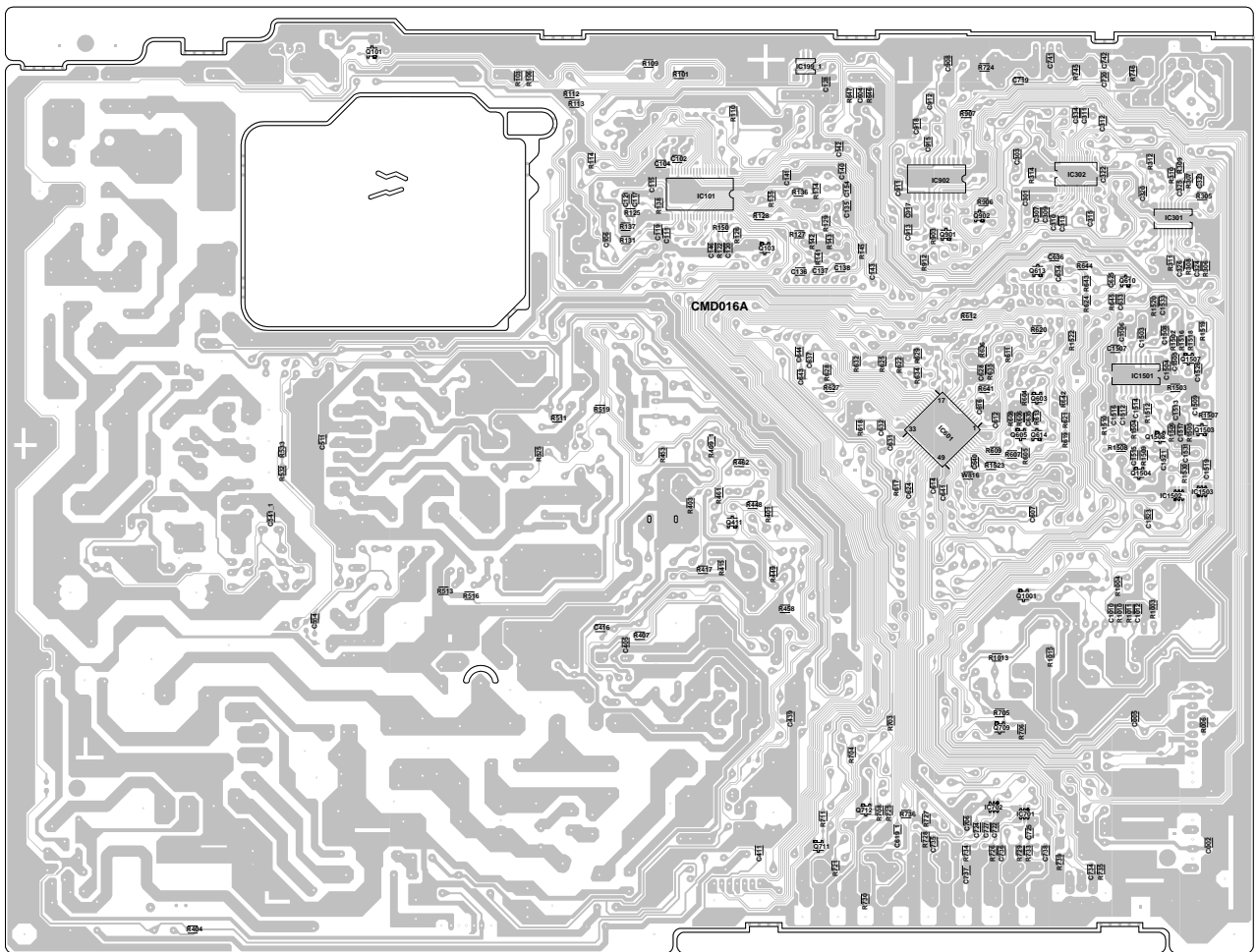

PRINTED CIRCUIT BOARDS

CRT/VM COIL
SOLDER SIDE

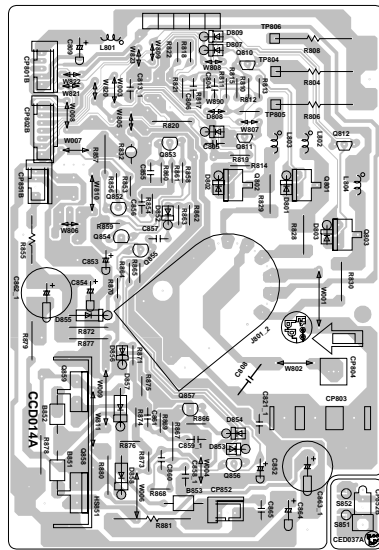

POWER
SOLDER SIDE

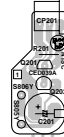

CHROMA SCHEMATIC DIAGRAM (MAIN PCB)

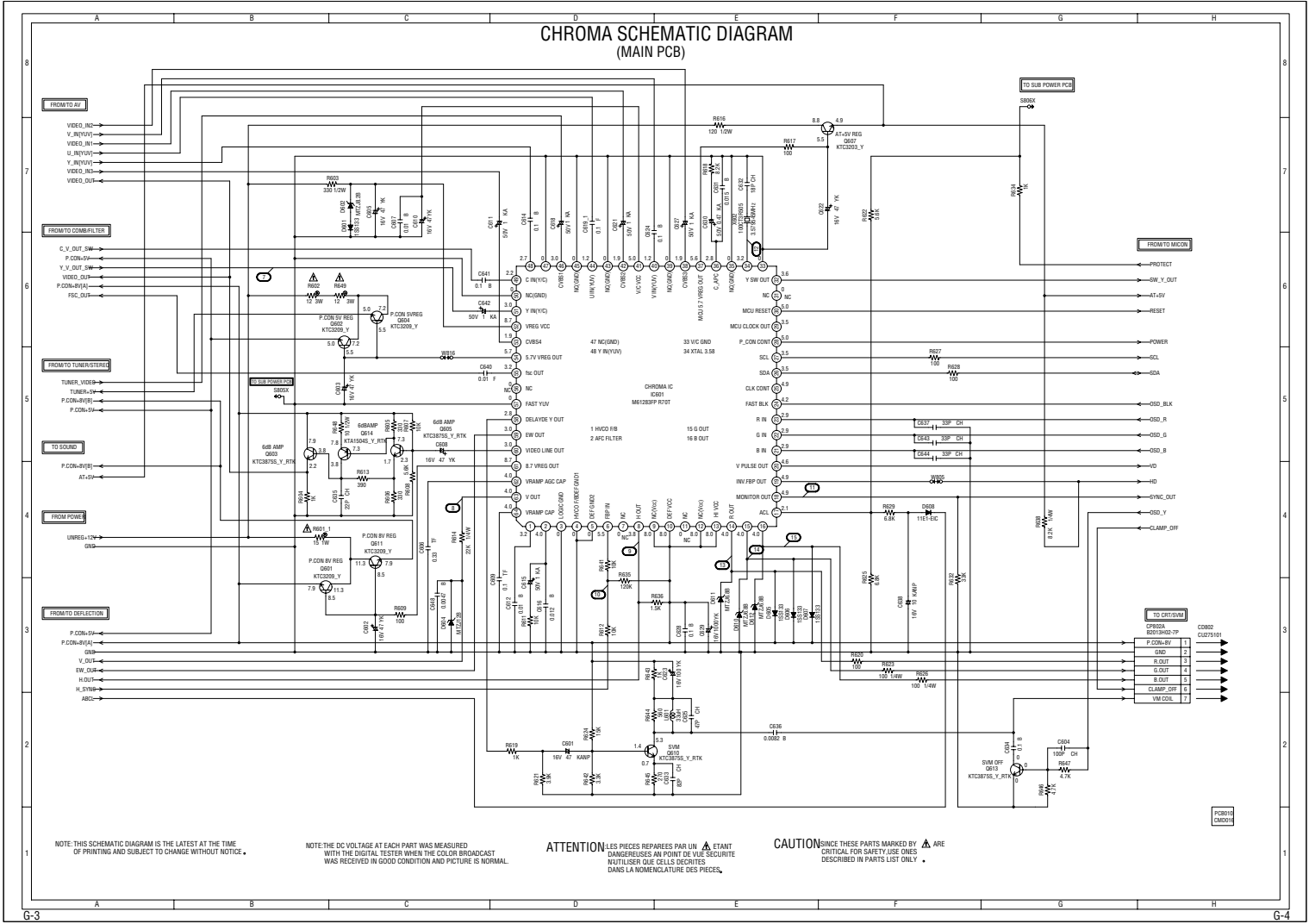

NOTE: THIS SCHEMATIC DIAGRAM IS THE LATEST AT THE TIME OF PRINTING AND SUBJECT TO CHANGE WITHOUT NOTICE.

NOTE: THE DC VOLTAGE AT EACH PART WAS MEASURED WITH THE DIGITAL TESTER WHEN THE COLOR BROADCAST WAS RECEIVED IN GOOD CONDITION AND PICTURE IS NORMAL.

ATTENTION LES PIÈCES RÉPARÉES PAR UN **⚠** ÉTANT DANGEREUSES À UN POINT DE VUE SÉCURITÉ UTILISER DES CELLULES SÉCURITÉ DANS LA NOMÉNCLATURE DES PIÈCES.

CAUTION SINCE THESE PARTS MARKED BY **⚠** ARE CRITICAL FOR SAFETY USE ONES DESCRIBED IN PARTS LIST ONLY.

PCB010
C8004

DEFLECTION SCHEMATIC DIAGRAM (MAIN PCB)

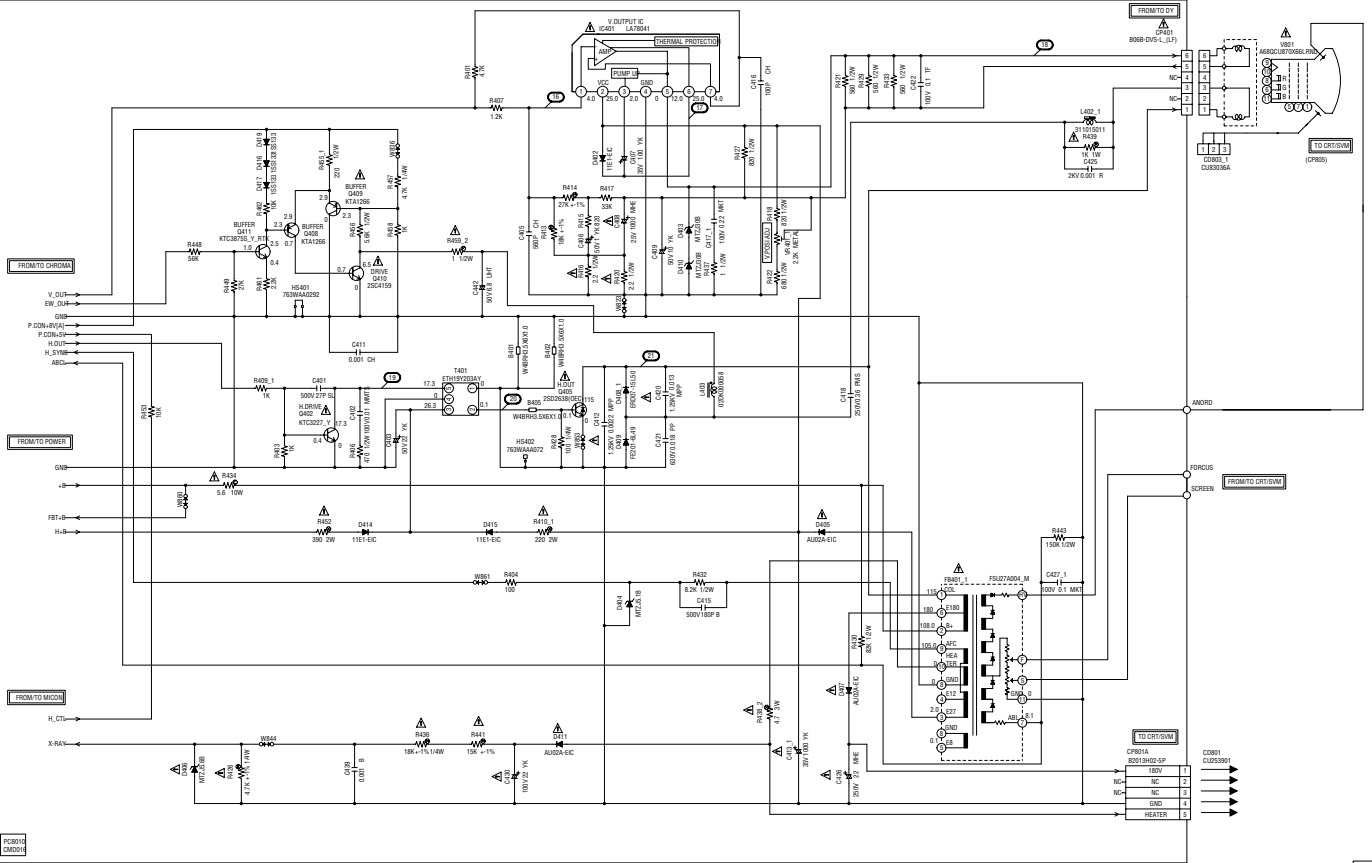

NOTE: THIS SCHEMATIC DIAGRAM IS THE LATEST AT THE TIME OF PRINTING AND SUBJECT TO CHANGE WITHOUT NOTICE.

NOTE: THE RESISTOR MARKED F IS FUSE RESISTOR. THE ALUMI ELECTROLYTIC CAPACITOR MARKED NP IS NON POLAR ONE.

ATTENTION: LES PIÈCES RÉPARÉES PAR UN **⚠** ÉTANT DANGEREUSES AN POINT DE VUE SÉCURITÉ, VOUS DEVEZ LES UTILISER QUE DANS LA NOMÉCLATURE DES PIÈCES.

CAUTION: SINCE THESE PARTS MARKED BY **⚠** ARE CRITICAL FOR SAFETY USE ONES DESCRIBED IN PARTS LIST ONLY.

NOTE: THE DC VOLTAGE AT EACH PART WAS MEASURED WITH THE DIGITAL TESTER WHEN THE COLOR BROADCAST WAS RECEIVED IN GOOD CONDITION AND PICTURE IS NORMAL.

POWER SCHEMATIC DIAGRAM (MAIN PCB)

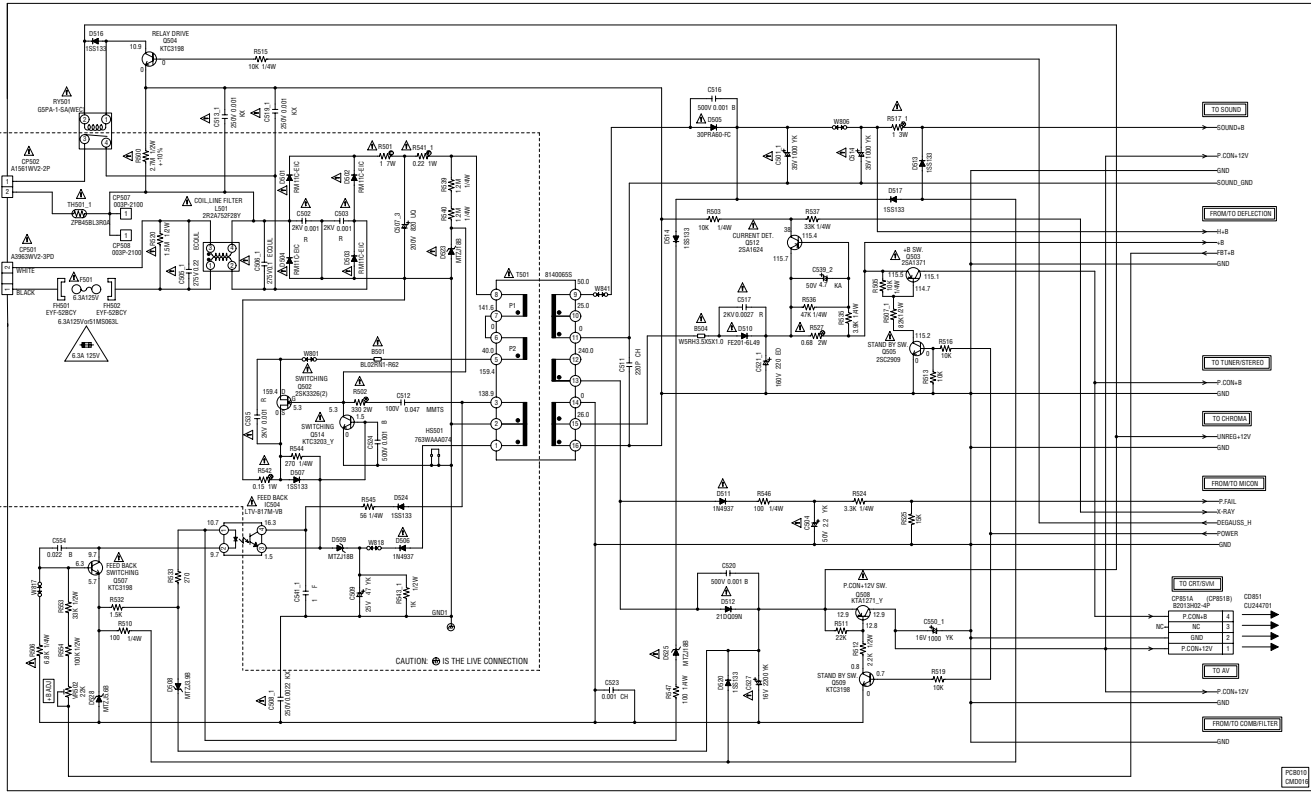

CAUTION FOR CONTINUED PROTECTION AGAINST FIRE HAZARD, REPLACE ONLY WITH THE SAME TYPE FUSE 6.3A 125V(F501) AND 5A 250V(ICP501).

ATTENTION POUR UNE PROTECTION CONTINUE LES RISQUES D'INCENDIE, UTILISER QUE DES FUSIBLE DE MEME TYPE 6.3A 125V(F501) ET 5A 250V(ICP501).

NOTE: THIS SCHEMATIC DIAGRAM IS THE LATEST AT THE TIME OF PRINTING AND SUBJECT TO CHANGE WITHOUT NOTICE.

NOTE: THE DC VOLTAGE AT EACH PART WAS MEASURED WITH THE DIGITAL TESTER WHEN THE COLOR BROADCAST WAS RECEIVED IN GOOD CONDITION AND PICTURE IS NORMAL.

NOTE: THE RESISTOR MARKED F IS FUSE RESISTOR. THE ALUMI ELECTROLYTIC CAPACITOR MARKED NP IS NON POLAR ONE.

ATTENTION LES PIÈCES REPARÉES PAR UN ÉTANT DANGEREUSES AU POINT DE VUE SÉCURITÉ UTILISER QUE CELLES DÉCRITES DANS LA NOMENCLATURE DES PIÈCES.

CAUTION SINCE THESE PARTS MARKED BY ARE CRITICAL FOR SAFETY, USE ONES DESCRIBED IN PARTS LIST ONLY.

SOUND SCHEMATIC DIAGRAM (MAIN PCB)

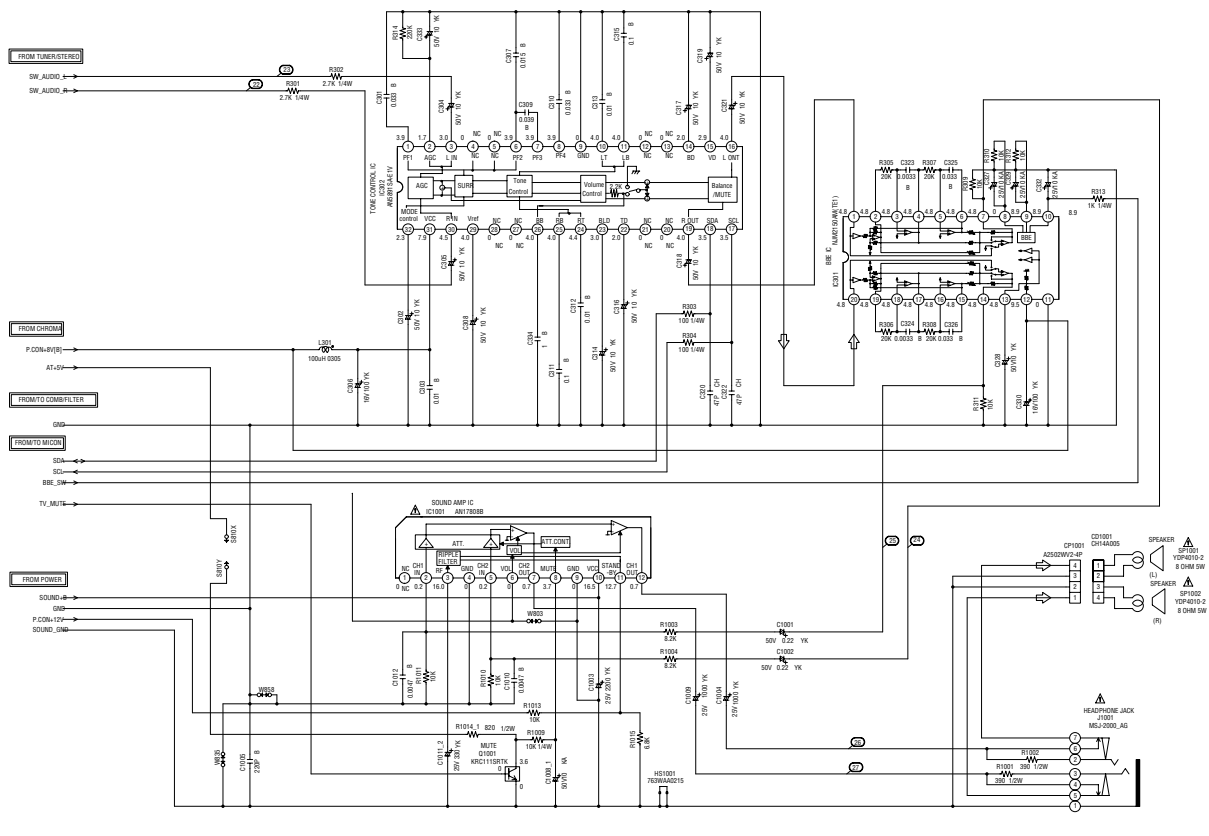

NOTE: THIS SCHEMATIC DIAGRAM IS THE LATEST AT THE TIME OF PRINTING AND SUBJECT TO CHANGE WITHOUT NOTICE.

NOTE: THE DC VOLTAGE AT EACH PART WAS MEASURED WITH THE DIGITAL TESTER WHEN THE COLOR BROADCAST WAS RECEIVED IN GOOD CONDITION AND PICTURE IS NORMAL.

ATTENTION LES PIÈCES RÉPARÉES PAR UN ÉTAIENT DANGEREUSES AN POINT DE VUE SECURITE N'UTILISER QUE CELLES DECRIRES DANS LA NOMENCLATURE DES PIÈCES.

CAUTION SINCE THESE PARTS MARKED BY ARE CRITICAL FOR SAFETY USE ONES DESCRIBED IN PARTS LIST ONLY.

CAUTION: DIGITAL TRANSISTOR

PCB010
CM2014

AV SCHEMATIC DIAGRAM (MAIN PCB)

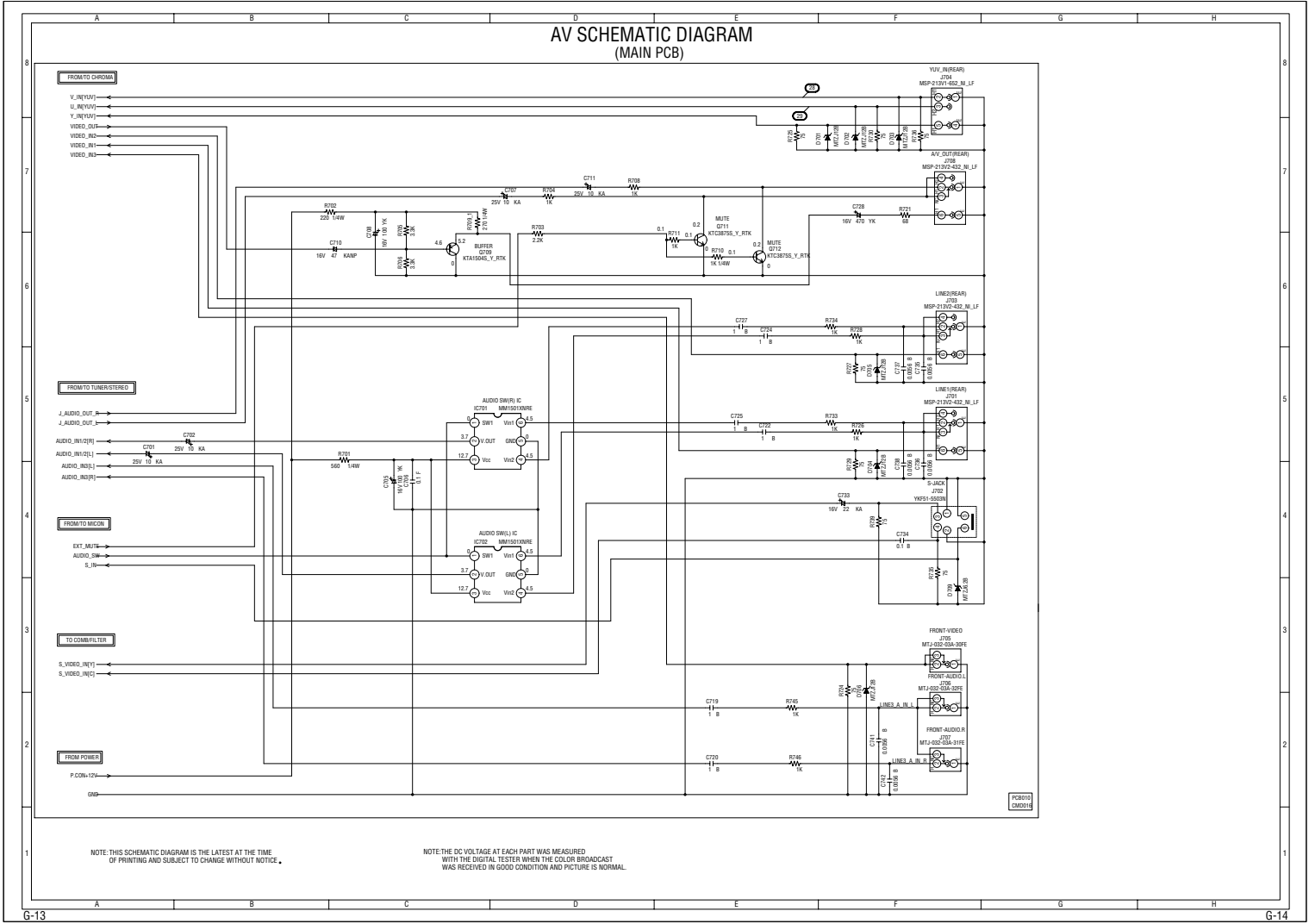

NOTE: THIS SCHEMATIC DIAGRAM IS THE LATEST AT THE TIME OF PRINTING AND SUBJECT TO CHANGE WITHOUT NOTICE.

NOTE: THE DC VOLTAGE AT EACH PART WAS MEASURED WITH THE DIGITAL TESTER WHEN THE COLOR BROADCAST WAS RECEIVED IN GOOD CONDITION AND PICTURE IS NORMAL.

COMB/FILTER SCHEMATIC DIAGRAM (MAIN PCB)

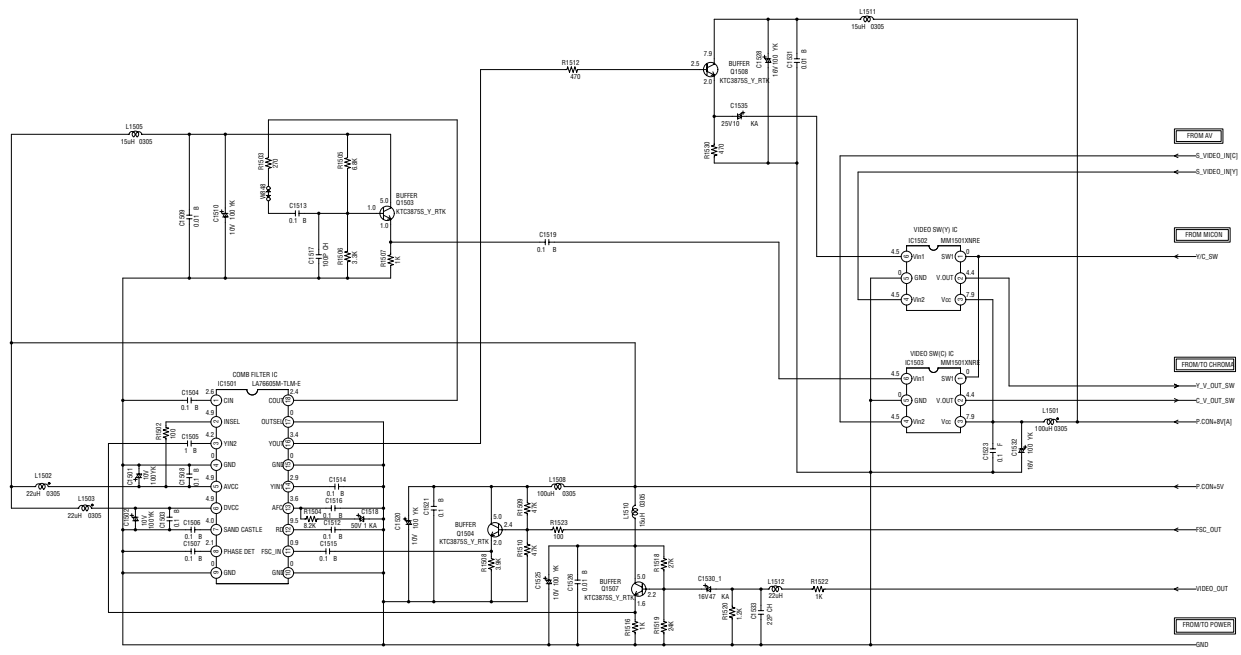

NOTE: THIS SCHEMATIC DIAGRAM IS THE LATEST AT THE TIME OF PRINTING AND SUBJECT TO CHANGE WITHOUT NOTICE.

NOTE: THE DC VOLTAGE AT EACH PART WAS MEASURED WITH THE DIGITAL TESTER WHEN THE COLOR BROADCAST WAS RECEIVED IN GOOD CONDITION AND PICTURE IS NORMAL.

FR010
CH010

CRT/SVM SCHEMATIC DIAGRAM (CRT PCB)

CRT BLOCK

SVM BLOCK

(VM COIL PCB)

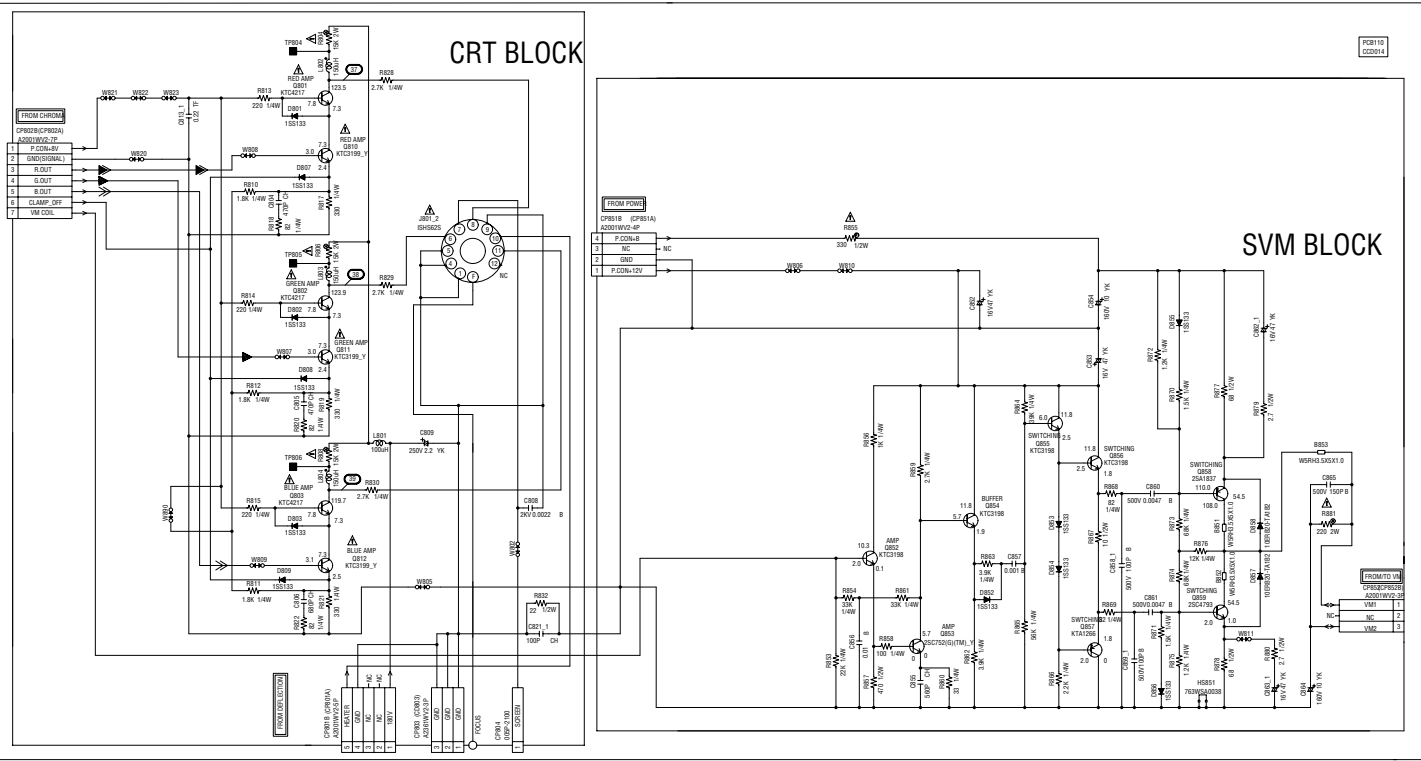

NOTE: THE DC VOLTAGE AT EACH PART WAS MEASURED WITH THE DIGITAL TESTER WHEN THE COLOR BROADCAST WAS RECEIVED IN GOOD CONDITION AND PICTURE IS NORMAL.

NOTE: THIS SCHEMATIC DIAGRAM IS THE LATEST AT THE TIME OF PRINTING AND SUBJECT TO CHANGE WITHOUT NOTICE.

CAUTION: SINCE THESE PARTS MARKED BY ARE CRITICAL FOR SAFETY, USE ONES DESCRIBED IN PARTS LIST ONLY.

ATTENTION: LES PIÈCES RÉPARÉES PAR UN ÉTANT DANGEREUSES AN POINT DE VUE SÉCURITÉ, UTILISER QUE CELLES DÉCRITES DANS LA NOMENCLATURE DES PIÈCES.

R. SIGNAL
 G. SIGNAL
 B. SIGNAL

SUB POWER SCHEMATIC DIAGRAM (POWER PCB)

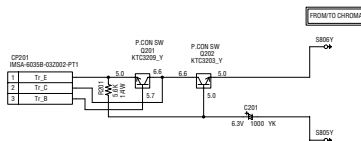

NOTE: THIS SCHEMATIC DIAGRAM IS THE LATEST AT THE TIME OF PRINTING AND SUBJECT TO CHANGE WITHOUT NOTICE.

NOTE: THE DC VOLTAGE AT EACH PART WAS MEASURED WITH THE DIGITAL TESTER WHEN THE COL OR BROADCAST WAS RECEIVED IN GOOD CONDITION AND PICTURE IS NORMAL.

CAUTION: DIGITAL TRANSISTOR

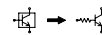

PCB240
CID039

WAVEFORMS

MICON

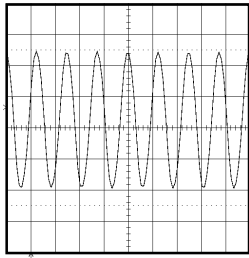

① 1V 0.1 μ s/div

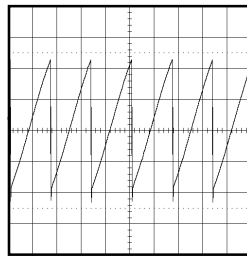

⑧ 0.5V 10ms/div

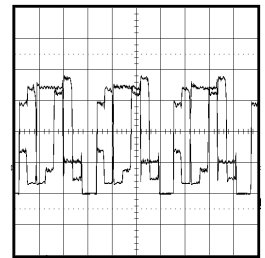

⑬ 1V 20 μ s/div

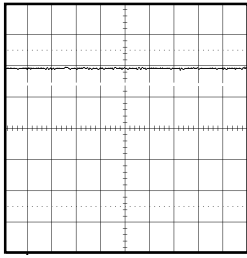

② 1V 1 μ s/div

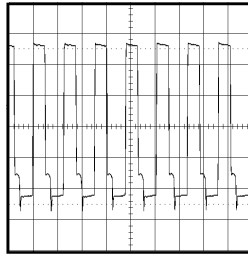

⑨ 1V 50 μ s/div

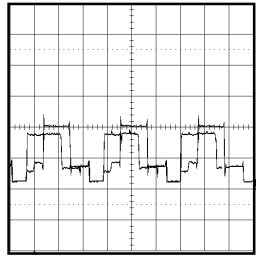

⑭ 2V 20 μ s/div

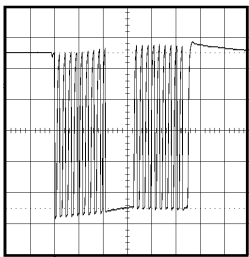

③ 1V 50 μ s/div

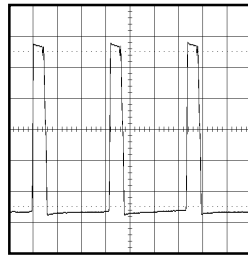

⑩ 2V 20 μ s/div

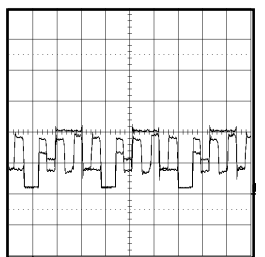

⑮ 2V 20 μ s/div

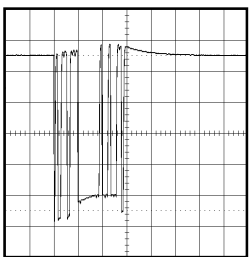

④ 1V 0.1ms/div

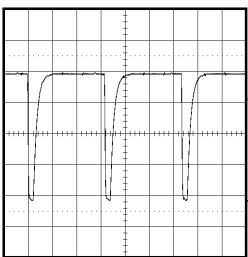

⑪ 0.5V 20 μ s/div

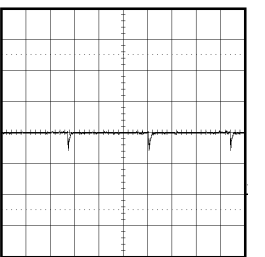

⑯ 2V 5ms/div

CHROMA

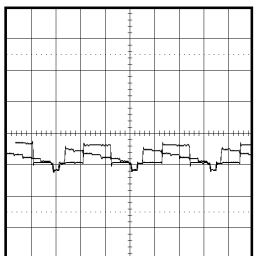

⑦ 1V 20 μ s/div

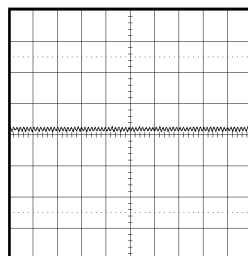

⑫ 1V 2 μ s/div

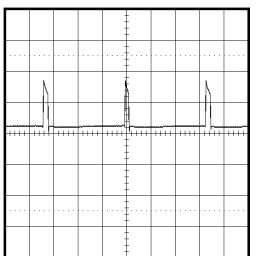

⑰ 20V 5ms/div

DEFLECTION

NOTE: The following waveforms were measured at the point of the corresponding balloon number in the schematic diagram.

WAVEFORMS

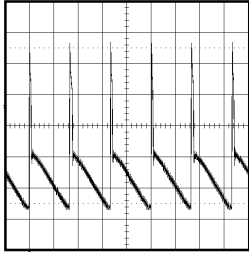

⑱ 10V 10ms/div

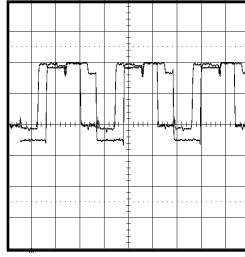

⑳ 50V 20 μ s/div

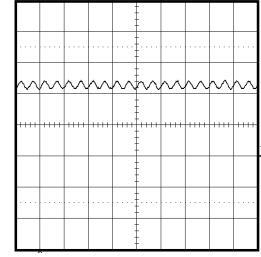

㉑ 2V 5ms/div

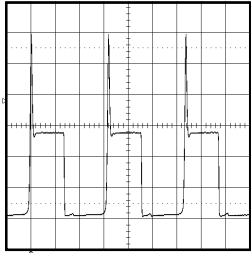

㉒ 20V 20 μ s/div

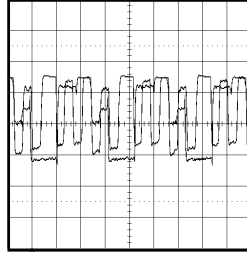

㉓ 50V 20 μ s/div

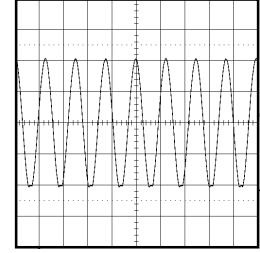

㉔ 5V 2ms/div

SOUND

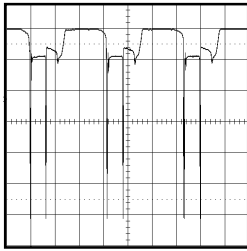

㉕ 2V 20 μ s/div

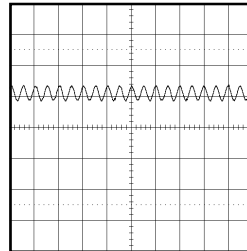

㉖ 2V 5ms/div

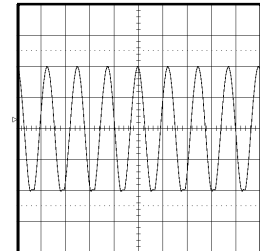

㉗ 5V 2ms/div

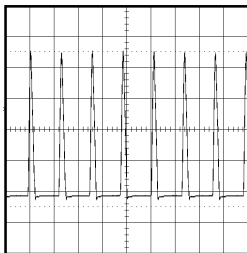

㉘ 200V 50 μ s/div

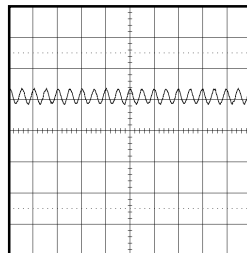

㉙ 2V 5ms/div

AV

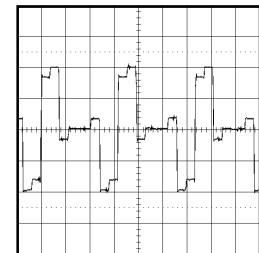

㉚ 200mV 20 μ s/div

CRT/SVM

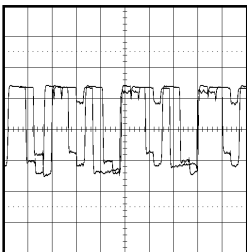

㉛ 50V 20 μ s/div

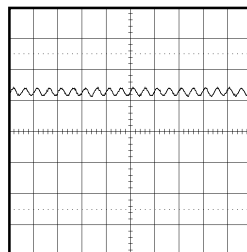

㉜ 2V 5ms/div

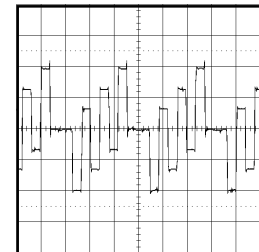

㉝ 200mV 20 μ s/div

NOTE: The following waveforms were measured at the point of the corresponding balloon number in the schematic diagram.

MECHANICAL EXPLODED VIEW

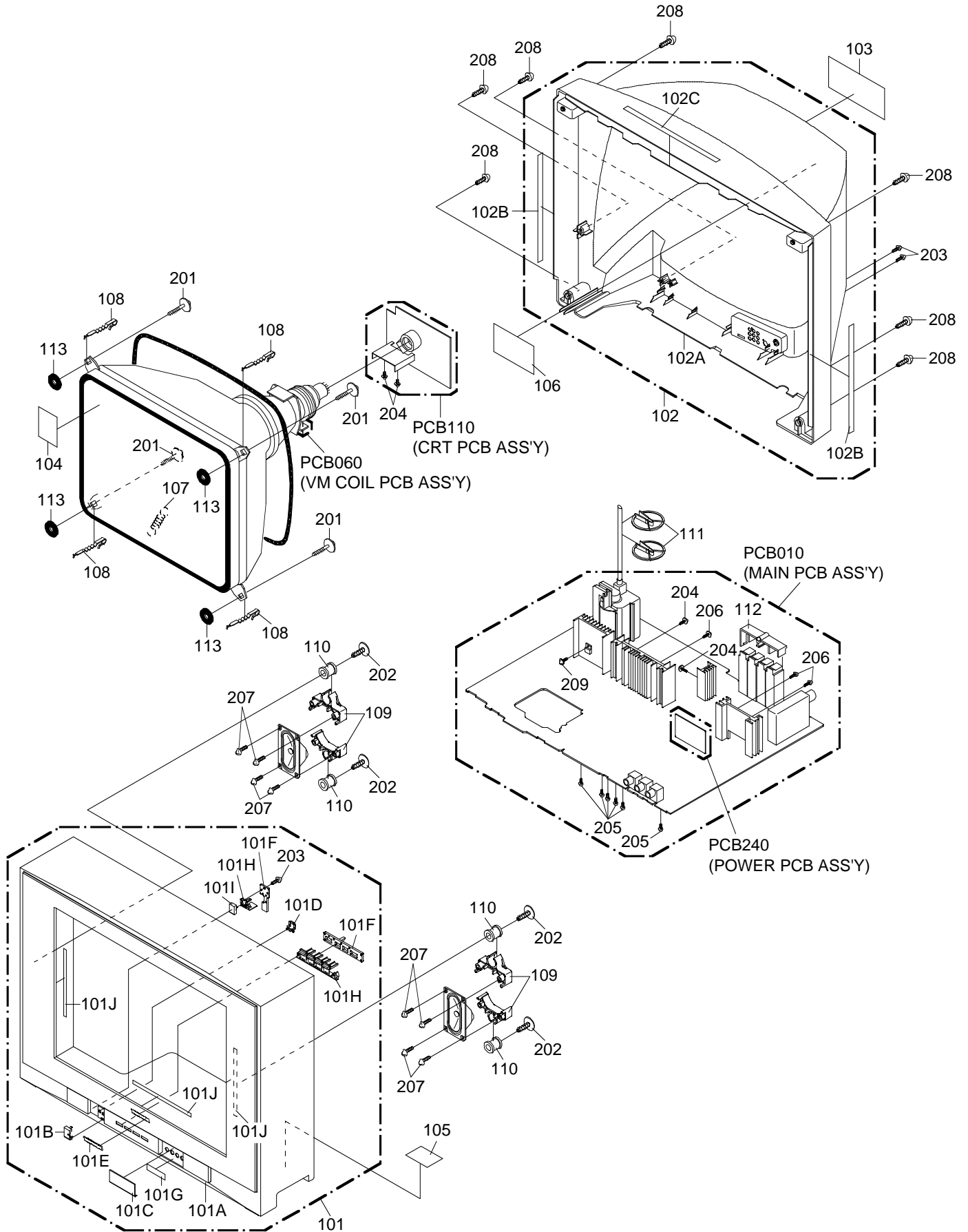

MECHANICAL EXPLODED VIEW (PACKING DIAGRAM)

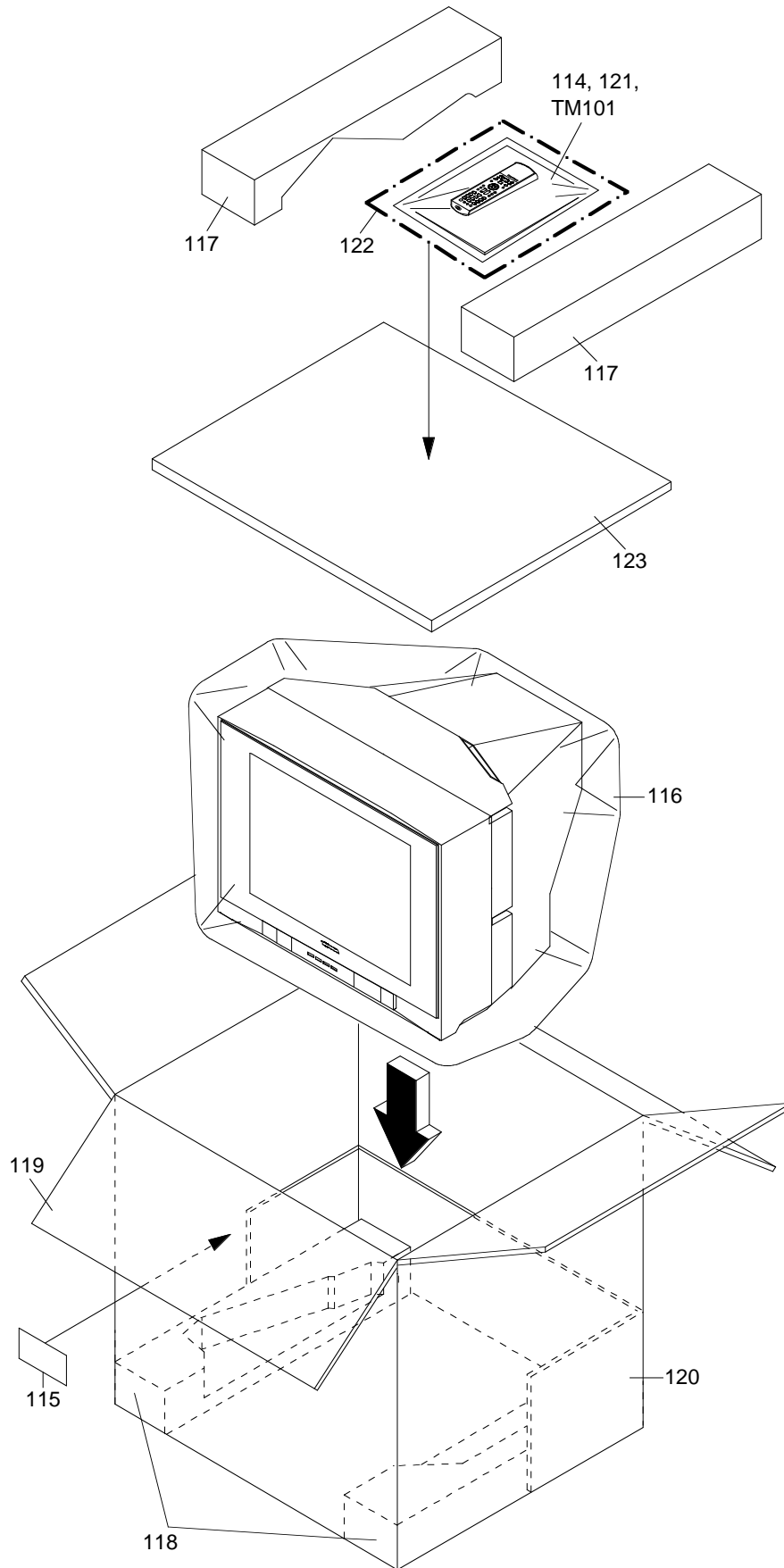

MECHANICAL REPLACEMENT PARTS LIST

Location No.	TSB P/N	Reference No.	Description
101	72783030	7A701A303A	FRONT CABI ASS'Y
101A	72782961	701WPJC913	CABINET,FRONT
101B	72783294	711WPAA130	PLATE,FRONT
101C	72782971	712WPBA115	DOOR
101D	72798518	713WPA0279	GLASS,LED
101E	72798569	7235490037	BADGE,BRAND
101F	72798589	735WPA0755	STOPPER,BUTTON
101G	72798573	723549A030	AV,LABEL
101H	72783013	735WPBB451	BUTTON,FRAME
101I	72783014	735WPJA847	BUTTON,POWER
101J	72796103	800WQ0A052	FELT SHEET
102	72781190	7A702A108A	BACK CABI ASS'Y
102A	72799355	702WPAA831	CABINET,BACK
102B	72781222	800WQ0A092	FELT SHEET
102C	72794727	800WQ0A076	FELT,SHEET
103	72783304	722549A569	SHEET RATING
104	72783305	723000D256	FILM DECORATION
105	72783250	724000A008	SHEET,CSA
106	72783297	726000A125	SHEET,CRT SERVICEMAN
107	72795687	741WUA0021	SPRING EARTH
108	72783298	762WPAA006	HOLDER CRT WIRE 2
109	72796254	761WPAA115	HOLDER SPEAKER
110	72794733	801WR00001	DAMPER SPEAKER
111	72794734	899HV3T000	HOLDER ANODE WIRE
112	72798672	761WPA0263	HOLDER,JACK
113	72798781	800WROA002	SHEET CRT SUPPORT
114	72783306	J3N12621A	INSTRUCTION BOOK(E/F)
115	72783307	723000D257	SHEET BAR CODE
116	72794741	791WHAA116	FILM,BAG
117	72798708	792WHA0460	PACKAGE,TOP
118	72798709	792WHA0461	PACKAGE,BOTTOM
119	72783308	793WCDD072	GIFT BOX
120	72795066	795WCA0665	PAD 378*1114
121	72795600	JA4ND100	POLYBAG INSTRUCTION(REDCAUTION)
122	72783309	A3N126Y975	INSTRUCTION BOOK KIT
123	72782503	791WHAA138	LIGHTRON SHEET
201	72781286	8141H60D5U	SCREW,TAP TITE(P) GW20 6*45 CH HEXAGON
202	72781295	8162540A6U	SCREW TAPPING (BO) WASHER 18
203	72798791	8110630A0U	SCREW TAP TITE(P) BRAZIER 3*10 CH
204	72798789	8109I30A0U	SCREW TAP TITE(B) WH7 3*10 CH
205	72781251	810963080Q	SCREW TAP TITE(B) BRAZIER 3*8 STAINLESS
206	72798786	810763080U	SCREW TAP TITE(S) BRAZIER 3*8 CH
207	72798790	811063080U	SCREW TAP TITE(P) BRAZIER 3*8 CH
208	72798795	8117540B0U	SCREW TAP TITE(B0) TRUSS 4*20 CH
209	72781255	8109I3080U	SCREW TAP TITE(B) WH7 3*8 CH

ELECTRICAL REPLACEMENT PARTS LIST

Location No.	TSB P/N	Reference No.	Description	
RESISTORS				
△R410	72794683	R3X18A221J	R,METAL OXIDE	220 OHM 2W
△R416	72794597	R002T22R2J	RC	2.2 OHM 1/2W
△R420	72794597	R002T22R2J	RC	2.2 OHM 1/2W
△R426	72794599	R4X5T4472F	R,METAL	4.7K OHM 1/4W
△R434	72795116	R5X2CF5R6J	R,CEMENT	5.6 OHM 10W
△R436	72795517	R4X5T4183F	R,METAL	18K OHM 1/4W
△R438	72797930	R3X28B4R7J	R,METAL OXIDE	4.7 OHM 3W
△R439	72796031	R3K181102J	R,METAL OXIDE	1K OHM 1W
△R441	72795516	R4X5T6153F	R,METAL	15K OHM 1/6W
△R452	72797882	R3X18A391J	R,METAL OXIDE	390 OHM 2W
△R459	72794614	R65582010J	R,FUSE	1 OHM 1/2W
△R500	72794631	R0G3K2275K	RC	2.7M OHM 1/2W
△R501	72795523	R5X2AE010J	R,CEMENT	1 OHM 7W
△R502	72795503	R3X28A331J	R,METAL OXIDE	330 OHM 2W
△R506	72794616	R002T4682J	RC	6.8K OHM 1/4W
R507	72797769	R00202823J	RC	82K OHM 1/2W
△R517	72794621	R3X28B010J	R,METAL OXIDE	1 OHM 3W
△R520	72795500	R002T2155J	RC	1.5M OHM 1/2W
△R527	72794624	R3X18AR68J	R,METAL OXIDE	0.68 OHM 2W
△R541	72794633	R63881R22J	R,FUSE	0.22 OHM 1W
△R542	72795513	R3X181R15J	R,METAL OXIDE	0.15 OHM 1W
R601	72795510	R3X181150J	R,METAL OXIDE	15 OHM 1W
△R602	72797913	R3X28B120J	R,METAL OXIDE	12 OHM 3W
△R649	72797913	R3X28B120J	R,METAL OXIDE	12 OHM 3W
△R804	72796459	R3X18A153J	R,METAL OXIDE	15K OHM 2W
△R806	72796459	R3X18A153J	R,METAL OXIDE	15K OHM 2W
△R808	72796459	R3X18A153J	R,METAL OXIDE	15K OHM 2W
△R855	72794663	R65582331J	R,FUSE	330 OHM 1/2W
△R881	72794683	R3X18A221J	R,METAL OXIDE	220 OHM 2W
R1014	72781659	R00202821J	RC	820 OHM 1/2W
CAPACITORS				
C155	72796339	P6M900105J	CMPL	1 UF 50V TF
△C408	72794410	E5EZF3102M	CE	1000 UF 25V
△C412	72797701	P4N8FJ222H	CMPP	0.0022UF 1.25KV
△C413	72797426	E0ELF4102M	CE	1000 UF 35V
C418	72782052	P4J7F3364J	CMPP	0.36 UF 250V PMS
△C420	72794391	P4N8FJ133H	CMPP	0.013 UF 1.25KV
C421	72795102	P3N1F5183J	CPP	0.018 UF 630V
C425	72794399	C0PLRR713K	CC	0.001 UF 2KV R
△C426	72794394	E5EZF220M	CE	22 UF 250V
△C430	72794396	E02LU8220M	CE	22 UF 100V
C442	72794397	E736F56R8M	CE	6.8 UF 50V
△C501	72794398	E02LF4102M	CE	1000 UF 35V
△C502	72794399	C0PLRR713K	CC	0.001 UF 2KV R
△C503	72794399	C0PLRR713K	CC	0.001 UF 2KV R
△C504	72795091	E02LU52R2M	CE	2.2 UF 50V
△C505	72795566	P2122B224M	CMP	0.22 UF 275V ECQUL
△C506	72795567	P2122B104M	CMP	0.1 UF 275V ECQUL
C507	72794402	E51DFC821M	CE	820 UF 200V
△C508	72794403	CD39E0MH3M	CC	0.0022UF 250V
△C513	72794409	CD39E0M13M	CC	0.001 UF 250V
△C514	72794398	E02LF4102M	CE	1000 UF 35V
△C517	72797086	C03L0R7K3K	CC	0.0027UF 2KV R
△C519	72794409	CD39E0M13M	CC	0.001 UF 250V
C521	72781390	E61DFB221M	CE	220 UF 160V
△C527	72796330	E02LF2222M	CE	2200 UF 16V
△C535	72794399	C0PLRR713K	CC	0.001 UF 2KV R
C648	72795577	CQG0B04Q3K	CC	0.0047UF 50V B
C808	72794440	C0JBB07H3K	CC	0.0022UF 2KV B
C1003	72795574	E02LF3222M	CE	2200 UF 25V
C1004	72794360	E02LF3102M	CE	1000 UF 25V
C1009	72794360	E02LF3102M	CE	1000 UF 25V
DIODES				
D001	72794465	D97U03301B	DIODE,ZENER	MTZJ33B T-77
D104	72794491	D1VT001330	DIODE,SILICON	1SS133T-77
D105	72794491	D1VT001330	DIODE,SILICON	1SS133T-77
D106	72794469	D97U05R11B	DIODE,ZENER	MTZJ5.1B T-77
D107	72794491	D1VT001330	DIODE,SILICON	1SS133T-77
D108	72794491	D1VT001330	DIODE,SILICON	1SS133T-77
D109	72795529	0021721150	LED	SLR-342VCT32
D110	72794491	D1VT001330	DIODE,SILICON	1SS133T-77
D113	72794489	D97U05R61B	DIODE,ZENER	MTZJ5.6B T-77
D402	72794488	D2WTO11E10	DIODE,SILICON	11E1-EIC
D403	72794471	D97U03001B	DIODE,ZENER	MTZJ30B T-77
D404	72794469	D97U05R11B	DIODE,ZENER	MTZJ5.1B T-77

ELECTRICAL REPLACEMENT PARTS LIST

Location No.	TSB P/N	Reference No.	Description	
DIODES				
△D405	72794472	D2WTAU02A0	DIODE,SILICON	AU02A-EIC
△D406	72794489	D97U05R61B	DIODE,ZENER	MTZJ5.6B T-77
△D407	72794472	D2WTAU02A0	DIODE,SILICON	AU02A-EIC
D408	72794470	D2CF0715L0	DIODE,SILICON	ERD07-15L50
D409	72794475	D2CF2016L0	DIODE,SILICON	FE201-6L49
D410	72794471	D97U03001B	DIODE,ZENER	MTZJ30B T-77
△D411	72794472	D2WTAU02A0	DIODE,SILICON	AU02A-EIC
D414	72794488	D2WT011E10	DIODE,SILICON	11E1-EIC
D415	72794488	D2WT011E10	DIODE,SILICON	11E1-EIC
D416	72794491	D1VT001330	DIODE,SILICON	1SS133T-77
D417	72794491	D1VT001330	DIODE,SILICON	1SS133T-77
D419	72794491	D1VT001330	DIODE,SILICON	1SS133T-77
△D501	72794473	D2WTRM11C0	DIODE,SILICON	RM11C-EIC
△D502	72794473	D2WTRM11C0	DIODE,SILICON	RM11C-EIC
△D503	72794473	D2WTRM11C0	DIODE,SILICON	RM11C-EIC
△D504	72794473	D2WTRM11C0	DIODE,SILICON	RM11C-EIC
△D505	72794474	D28F0PRA60	DIODE,RECTIFIER	30PRA60-FC
△D506	72794483	D2WXN49370	DIODE,SILICON	1N4937
D507	72794491	D1VT001330	DIODE,SILICON	1SS133T-77
D508	72795542	D97U03R91B	DIODE,ZENER	MTZJ3.9B T-77
D509	72795541	D97U01801B	DIODE,ZENER	MTZJ18B T-77
△D510	72794475	D2CF2016L0	DIODE,SILICON	FE201-6L49
△D511	72794483	D2WXN49370	DIODE,SILICON	1N4937
△D512	72794480	D28T21DQN9	DIODE,SCHOTTKY	21DQ09N-TA2B1
D513	72794491	D1VT001330	DIODE,SILICON	1SS133T-77
D514	72794491	D1VT001330	DIODE,SILICON	1SS133T-77
D516	72794491	D1VT001330	DIODE,SILICON	1SS133T-77
D517	72794491	D1VT001330	DIODE,SILICON	1SS133T-77
D520	72794491	D1VT001330	DIODE,SILICON	1SS133T-77
△D523	72795541	D97U01801B	DIODE,ZENER	MTZJ18B T-77
D524	72794491	D1VT001330	DIODE,SILICON	1SS133T-77
△D525	72795541	D97U01801B	DIODE,ZENER	MTZJ18B T-77
D528	72794489	D97U05R61B	DIODE,ZENER	MTZJ5.6B T-77
D601	72794491	D1VT001330	DIODE,SILICON	1SS133T-77
D602	72794486	D97U08R21B	DIODE,ZENER	MTZJ8.2B T-77
D604	72794487	D97U01201B	DIODE,ZENER	MTZJ12B T-77
D605	72794491	D1VT001330	DIODE,SILICON	1SS133T-77
D606	72794491	D1VT001330	DIODE,SILICON	1SS133T-77
D607	72794491	D1VT001330	DIODE,SILICON	1SS133T-77
D608	72794488	D2WT011E10	DIODE,SILICON	11E1-EIC
D610	72794478	D97U06R81B	DIODE,ZENER	MTZJ6.8B T-77
D611	72794478	D97U06R81B	DIODE,ZENER	MTZJ6.8B T-77
D612	72794478	D97U06R81B	DIODE,ZENER	MTZJ6.8B T-77
D701	72794487	D97U01201B	DIODE,ZENER	MTZJ12B T-77
D702	72794487	D97U01201B	DIODE,ZENER	MTZJ12B T-77
D703	72794487	D97U01201B	DIODE,ZENER	MTZJ12B T-77
D704	72794487	D97U01201B	DIODE,ZENER	MTZJ12B T-77
D705	72794487	D97U01201B	DIODE,ZENER	MTZJ12B T-77
D706	72794487	D97U01201B	DIODE,ZENER	MTZJ12B T-77
D709	72794490	D97U06R21B	DIODE,ZENER	MTZJ6.2B T-77
D801	72794491	D1VT001330	DIODE,SILICON	1SS133T-77
D802	72794491	D1VT001330	DIODE,SILICON	1SS133T-77
D803	72794491	D1VT001330	DIODE,SILICON	1SS133T-77
D807	72794491	D1VT001330	DIODE,SILICON	1SS133T-77
D808	72794491	D1VT001330	DIODE,SILICON	1SS133T-77
D809	72794491	D1VT001330	DIODE,SILICON	1SS133T-77
D852	72794491	D1VT001330	DIODE,SILICON	1SS133T-77
D853	72794491	D1VT001330	DIODE,SILICON	1SS133T-77
D854	72794491	D1VT001330	DIODE,SILICON	1SS133T-77
D855	72794491	D1VT001330	DIODE,SILICON	1SS133T-77
D856	72794491	D1VT001330	DIODE,SILICON	1SS133T-77
D857	72796388	D28T0ERB20	DIODE,RECTIFIER	10ERB20-TA1B2
D858	72796388	D28T0ERB20	DIODE,RECTIFIER	10ERB20-TA1B2
ICS				
IC101	72795533	I56F07090B	IC	OEC7090B
IC199	72783303	A3N124Y015	INIT DATA	BR24L16FJ-WE2
IC301	72781448	I0QJ021500	IC	NJM2150AM(TE1)
IC302	72794498	I01FF58910	IC	AN5891SA-E1V
△IC401	72794507	I03TD80410	IC	LA78041
△IC504	72795524	0002E00610	PHOTO COUPLER	LTV-817M-VB
IC601	72797552	I06FC1283A	IC	M61283FP R70T
IC701	72794502	I0UF015010	IC	MM1501XNRE
IC702	72794502	I0UF015010	IC	MM1501XNRE
IC902	72795535	I01FF58290	IC	AN5829S-E1V
△IC1001	72794497	I0FSP7808B	IC	AN17808B

ELECTRICAL REPLACEMENT PARTS LIST

Location No.	TSB P/N	Reference No.	Description ICS	
IC1501	72797544	I03FE76605	IC	LA76605M-TLM-E
IC1502	72794502	I0UF015010	IC	MM1501XNRE
IC1503	72794502	I0UF015010	IC	MM1501XNRE
TRANSISTORS				
Q101	72794571	TCAA3875SY	TRANSISTOR,SILICON	KTC3875S_Y_RTK
Q103	72794571	TCAA3875SY	TRANSISTOR,SILICON	KTC3875S_Y_RTK
Q201	72794570	TCAT03209Y	TRANSISTOR,SILICON	KTC3209_Y-AT
Q202	72795476	TCAT032034	TRANSISTOR,SILICON	KTC3203_Y-AT
△Q402	72794561	TCAT03227Y	TRANSISTOR,SILICON	KTC3227_Y-AT
△Q405	72794562	TD50026380	TRANSISTOR,SILICON	2SD2638(OEC)
Q408	72794578	TAATA12660	TRANSISTOR,SILICON	KTA1266-AT(Y,GR)
△Q409	72794578	TAATA12660	TRANSISTOR,SILICON	KTA1266-AT(Y,GR)
△Q410	72794563	TC30041590	TRANSISTOR,SILICON	2SC4159(D,E)
Q411	72794571	TCAA3875SY	TRANSISTOR,SILICON	KTC3875S_Y_RTK
△Q502	72795540	T220033260	FET	2SK3326(2)
△Q503	72795475	TA3T1371A0	TRANSISTOR,SILICON	2SA1371(D,E)-AE
Q504	72794577	TCATC31980	TRANSISTOR,SILICON	KTC3198-AT(Y,GR)
△Q505	72795474	TC3T029090	TRANSISTOR,SILICON	2SC2909(S,T)-AA
△Q507	72794577	TCATC31980	TRANSISTOR,SILICON	KTC3198-AT(Y,GR)
△Q508	72798324	TAAT012714	TRANSISTOR,SILICON	KTA1271_Y-AT
Q509	72794577	TCATC31980	TRANSISTOR,SILICON	KTC3198-AT(Y,GR)
△Q512	72794569	TA3T016240	TRANSISTOR,SILICON	2SA1624-AA
△Q514	72795476	TCAT032034	TRANSISTOR,SILICON	KTC3203_Y-AT
Q601	72794570	TCAT03209Y	TRANSISTOR,SILICON	KTC3209_Y-AT
Q602	72794570	TCAT03209Y	TRANSISTOR,SILICON	KTC3209_Y-AT
Q603	72794571	TCAA3875SY	TRANSISTOR,SILICON	KTC3875S_Y_RTK
Q604	72794570	TCAT03209Y	TRANSISTOR,SILICON	KTC3209_Y-AT
Q605	72794571	TCAA3875SY	TRANSISTOR,SILICON	KTC3875S_Y_RTK
Q607	72795476	TCAT032034	TRANSISTOR,SILICON	KTC3203_Y-AT
Q610	72794571	TCAA3875SY	TRANSISTOR,SILICON	KTC3875S_Y_RTK
Q611	72794570	TCAT03209Y	TRANSISTOR,SILICON	KTC3209_Y-AT
Q613	72794571	TCAA3875SY	TRANSISTOR,SILICON	KTC3875S_Y_RTK
Q614	72794566	TAAA1504SY	TRANSISTOR,SILICON	KTA1504S_Y_RTK
Q709	72794566	TAAA1504SY	TRANSISTOR,SILICON	KTA1504S_Y_RTK
Q711	72794571	TCAA3875SY	TRANSISTOR,SILICON	KTC3875S_Y_RTK
Q712	72794571	TCAA3875SY	TRANSISTOR,SILICON	KTC3875S_Y_RTK
△Q801	72794574	TCA0042170	TRANSISTOR,SILICON	KTC4217(O,Y)
△Q802	72794574	TCA0042170	TRANSISTOR,SILICON	KTC4217(O,Y)
△Q803	72794574	TCA0042170	TRANSISTOR,SILICON	KTC4217(O,Y)
△Q810	72794573	TCATC3199Y	TRANSISTOR,SILICON	KTC3199_Y-AT
△Q811	72794573	TCATC3199Y	TRANSISTOR,SILICON	KTC3199_Y-AT
△Q812	72794573	TCATC3199Y	TRANSISTOR,SILICON	KTC3199_Y-AT
Q852	72794577	TCATC31980	TRANSISTOR,SILICON	KTC3198-AT(Y,GR)
Q853	72794575	TCUT00752Y	TRANSISTOR,SILICON	2SC752(G)(TM)_Y
Q854	72794577	TCATC31980	TRANSISTOR,SILICON	KTC3198-AT(Y,GR)
Q855	72794577	TCATC31980	TRANSISTOR,SILICON	KTC3198-AT(Y,GR)
Q856	72794577	TCATC31980	TRANSISTOR,SILICON	KTC3198-AT(Y,GR)
Q857	72794578	TAATA12660	TRANSISTOR,SILICON	KTA1266-AT(Y,GR)
Q858	72795972	TAU0018370	TRANSISTOR,SILICON	2SA1837
Q859	72795973	TCU0047930	TRANSISTOR,SILICON	2SC4793
Q901	72794566	TAAA1504SY	TRANSISTOR,SILICON	KTA1504S_Y_RTK
Q902	72794566	TAAA1504SY	TRANSISTOR,SILICON	KTA1504S_Y_RTK
Q1001	72798353	TNAAJ05003	COMPOUND TRANSISTOR	KRC111SRTK
Q1503	72794571	TCAA3875SY	TRANSISTOR,SILICON	KTC3875S_Y_RTK
Q1504	72794571	TCAA3875SY	TRANSISTOR,SILICON	KTC3875S_Y_RTK
Q1507	72794571	TCAA3875SY	TRANSISTOR,SILICON	KTC3875S_Y_RTK
Q1508	72794571	TCAA3875SY	TRANSISTOR,SILICON	KTC3875S_Y_RTK
COILS & TRANSFORMERS				
L301	72794540	02167F101J	COIL	100 UH
L402	72782055	022K00051A	COIL,LINEARITY	311015011
L403	72794529	02DK000058	COIL,CHOKE	02DK000058
△L501	72794530	029T000101	COIL,LINE FILTER	2R2A752F28Y
△L503	72783288	028R270019	COIL,DEGAUSS	8R270019
L601	72794536	021LA6330J	COIL	33 UH
L801	72795941	021673101K	COIL	100 UH
L802	72795931	021673151K	COIL	150 UH
L803	72795931	021673151K	COIL	150 UH
L804	72795931	021673151K	COIL	150 UH
L901	72794540	02167F101J	COIL	100 UH
L1501	72794540	02167F101J	COIL	100 UH
L1502	72794526	02167F220J	COIL	22 UH
L1503	72794526	02167F220J	COIL	22 UH
L1505	72795932	02167F150J	COIL	15 UH
L1508	72794540	02167F101J	COIL	100 UH
L1510	72795932	02167F150J	COIL	15 UH

ELECTRICAL REPLACEMENT PARTS LIST

Location No.	TSB P/N	Reference No.	Description	
COILS & TRANSFORMERS				
L1511	72795932	02167F150J	COIL	15 UH
L1512	72796571	021LA6220J	COIL	22 UH
T401	72795486	0450190161	TRANS,HORIZONTAL DRIVE	ETH19Y203AY
△T501	72796703	048140065S	TRANSFORMER,SWITCHING	8140065S
JACKS				
J701	72794518	060J431020	RCA JACK	MSP-213V2-432_NI_LF
J702	72794517	063Q700011	JACK	YKF51-5503N
J703	72794518	060J431020	RCA JACK	MSP-213V2-432_NI_LF
J704	72795493	060J411032	RCA JACK	MSP-213V1-652_NI_LF
J705	72794519	060J401104	RCA JACK	MTJ-032-03A-30FE
J706	72794520	060J401106	RCA JACK	MTJ-032-03A-32FE
J707	72794521	060J401105	RCA JACK	MTJ-032-03A-31FE
J708	72794518	060J431020	RCA JACK	MSP-213V2-432_NI_LF
△J801	72794523	066F130021	SOCKET,CATHODE RAY,TUBE	ISHS62S
△J1001	72794516	060J131016	HEADPHONE JACK	MSJ-2000_AG
SWITCHES				
SW101	72794688	0504101T34	SWITCH,TACT	EVQ21505R
SW102	72794688	0504101T34	SWITCH,TACT	EVQ21505R
SW103	72794688	0504101T34	SWITCH,TACT	EVQ21505R
SW104	72794688	0504101T34	SWITCH,TACT	EVQ21505R
SW105	72794688	0504101T34	SWITCH,TACT	EVQ21505R
VARIABLE RESISTORS				
VR401	72795471	V1K63H3BTE	VOLUME,SEMI FIXED	NVG6TLTAB222
VR502	72794701	V1163H4BTC	VOLUME,SEMI FIXED	EVNCYAA03BE4
P.C.BOARD ASSEMBLIES				
PCB010	72783165	A3N124Y010	PCB ASSY	CMD016A
PCB060	72783289	A3N126Y060	PCB ASSY	CED037A
PCB110	72783290	A3N126Y110	PCB ASSY	CCD014A
PCB240	72783291	A3N126Y240	PCB ASSY	CED039A
MISCELLANEOUS				
B401	72794356	024HT03564	CORE,BEADS	W4BRH3.5X6X1.0
B402	72794356	024HT03564	CORE,BEADS	W4BRH3.5X6X1.0
B405	72794356	024HT03564	CORE,BEADS	W4BRH3.5X6X1.0
△B501	72795549	024AT03481	CORE,BEADS	BL02RN1-R62T2
△B504	72794357	024HT03553	CORE,BEADS	W5RH3.5X5X1.0
B851	72794357	024HT03553	CORE,BEADS	W5RH3.5X5X1.0
B852	72794357	024HT03553	CORE,BEADS	W5RH3.5X5X1.0
B853	72794357	024HT03553	CORE,BEADS	W5RH3.5X5X1.0
BT001	72783174	141U004016	BATTERY,MANGAN	MNAAA(R03)
BT002	72783174	141U004016	BATTERY,MANGAN	MNAAA(R03)
△CD501	72795553	1209615904	CORD,AC BUSH	9615904
CD801	72796887	06CU253901	CORD,CONNECTOR	CU253901
CD802	72796889	06CU275101	CORD,CONNECTOR	CU275101
CD803	72795883	06CU83036A	CORD,CONNECTOR	CU83036A
CD851	72796883	06CU244701	CORD,CONNECTOR	CU244701
CD852	72794464	06CU232001	CORD,CONNECTOR	CU232001
CP101	72796802	069S270639	CONNECTOR PCB SIDE	A2001WR2-7P
CP201	72799031	069J130340	CONNECTOR PCB SIDE	IMSA-6035B-03Z002-PT
△CP401	72782003	069X460109	CONNECTOR PCB SIDE	B06B-DVS-L_(LF)
△CP501	72796817	069S320419	CONNECTOR PCB SIDE	A3963WV2-3PD
△CP502	72796821	069S420110	CONNECTOR PCB SIDE	A1561WV2-2P
CP507	72796768	069D01001A	CONNECTOR PCB SIDE	003P-2100
CP508	72796768	069D01001A	CONNECTOR PCB SIDE	003P-2100
CP803	72796818	069S330010	CONNECTOR PCB SIDE	A2361WV2-3P
CP804	72796824	069W010010	CONNECTOR PCB SIDE	005P-2100
CP852	72796794	069S230629	CONNECTOR PCB SIDE	A2001WV2-3P
CD1001	72782836	06CH14A005	CORD,CONNECTOR	CH14A005
CP1001	72796793	069S140419	CONNECTOR PCB SIDE	A2502WV2-4P
CP801A	72796751	067U005049	WIRE HOLDER	B2013H02-5P
CP801B	72796798	069S250629	CONNECTOR PCB SIDE	A2001WV2-5P
CP802A	72796753	067U007029	WIRE HOLDER	B2013H02-7P
CP802B	72796801	069S270629	CONNECTOR PCB SIDE	A2001WV2-7P
CP851A	72796750	067U004029	WIRE HOLDER	B2013H02-4P
CP851B	72796796	069S240629	CONNECTOR PCB SIDE	A2001WV2-4P
CP852B	72796749	067U003029	WIRE HOLDER	B2013H02-3P
EL001	72797070	124120301A	EYE LET	XRY20X30BD
EL002	72797069	124116281A	EYE LET	XRY16X28BD
△F501	72794493	081PC6R305	FUSE	51MS063L
△FB401	72796673	043227017F	TRANSFORMER,FLYBACK	FSU27A004_M
FH501	72794496	06710T0009	HOLDER,FUSE	EYF-52BCY
FH502	72794496	06710T0009	HOLDER,FUSE	EYF-52BCY
OS101	72794541	0773071001	REMOTE RECEIVER	RPM7138-WH5
△RY501	72794686	0560X20118	RELAY	G5PA-1-SA(WEC)
△SP1001	72799166	070N546012	SPEAKER	YDP4010-2
△SP1002	72799166	070N546012	SPEAKER	YDP4010-2

ELECTRICAL REPLACEMENT PARTS LIST

Location No.	TSB P/N	Reference No.	Description	
COILS & TRANSFORMERS				
△TH501	72795546	DF5EL3R0A0	DEGAUSS ELEMENT	ZPB45BL3R0A
TM101	72796939	076R0GW020	TRANSMITTER	R25-1943
△TU001	72795492	0163300018	RF UNIT	115-V-KA35ARB
△V801	72783267	098S270914	CRT W/DY	A68QCU870X66LRND
X101	72794702	100CT8R005	CRYSTAL	HC-49/U-S
X602	72794703	100CT3R505	CRYSTAL	HC-49/U

RESISTOR

RC..... CARBON RESISTOR

CAPACITORS

CC..... CERAMIC CAPACITOR
 CE..... ALUMI ELECTROLYTIC CAPACITOR
 CP..... POLYESTER CAPACITOR
 CPP..... POLYPROPYLENE CAPACITOR
 CPL..... PLASTIC CAPACITOR
 CMP..... METAL POLYESTER CAPACITOR
 CMPL..... METAL PLASTIC CAPACITOR
 CMPP..... METAL POLYPROPYLENE CAPACITOR

TOSHIBA CORPORATION

1-1, SHIBAURA 1-CHOME, MINATO-KU, TOKYO 105-8001, JAPAN